



US00D391908S

United States Patent [19]

Allendorph et al.

[11] Patent Number: **Des. 391,908**

[45] Date of Patent: ****Mar. 10, 1998**

[54] EXTERIOR SHELL OF A VEHICLE HOOD

[75] Inventors: **L. David Allendorph; Richard B. Hatch**, both of Fort Wayne; **Robert M. Zimmerman**, Kendallville; **Franz Mueller**, Fort Wayne, all of Ind.

[73] Assignee: **Navistar International Transportation Corp.**, Chicago, Ill.

[**] Term: **14 Years**

[21] Appl. No.: **47,793**

[22] Filed: **Oct. 12, 1995**

[51] LOC (6) Cl. **12-16**

[52] U.S. Cl. **D12/173**

[58] Field of Search D12/96, 97, 173;
296/190, 180.1, 91, 180.2; 180/89.12, 89.13,
89.67, 89.7

[56] References Cited

U.S. PATENT DOCUMENTS

D. 305,746	1/1990	Allendorph	D12/96
D. 306,421	3/1990	Allendorph et al.	D12/173
D. 306,714	3/1990	Allendorph et al.	D12/173
D. 307,126	4/1990	Allendorph et al.	D12/173
D. 307,878	5/1990	Lechner	D12/96
D. 320,583	10/1991	Simons et al.	D12/96
D. 328,273	7/1992	McGrew, Jr. et al.	D12/173
D. 366,638	1/1996	Tucker et al.	D12/173
5,308,134	5/1994	Stanesic	296/91

OTHER PUBLICATIONS

"Travel in the Height of Comfort With the 9000 Conventional Hi-Rise Sleeper" Brochure No. AD-42881V, Navistar International Transportation Corp., 1991.

Primary Examiner—Melody N. Brown
Attorney, Agent, or Firm—Dennis K. Sullivan

[57] CLAIM

The ornamental design for an exterior shell of a vehicle hood, as shown and described.

DESCRIPTION

FIG. 1 is a left, front perspective view of an exterior shell of a vehicle hood showing our new design, it being understood that the broken lines are for illustrative purposes only and form no part of the claimed design;

FIG. 2 is a left side elevation view thereof, the right side being a mirror image of that shown;

FIG. 3 is a top plan view thereof;

FIG. 4 is a front elevation view thereof;

FIG. 5 is a top plan view of an exterior shell of a vehicle hood showing a second embodiment of our new design; and,

FIG. 6 is a right side elevation view of the embodiment of FIG. 5, the left side being a mirror image of that shown.

The front elevation of the embodiment of FIG. 5 is identical to that shown in FIG. 4.

1 Claim, 3 Drawing Sheets

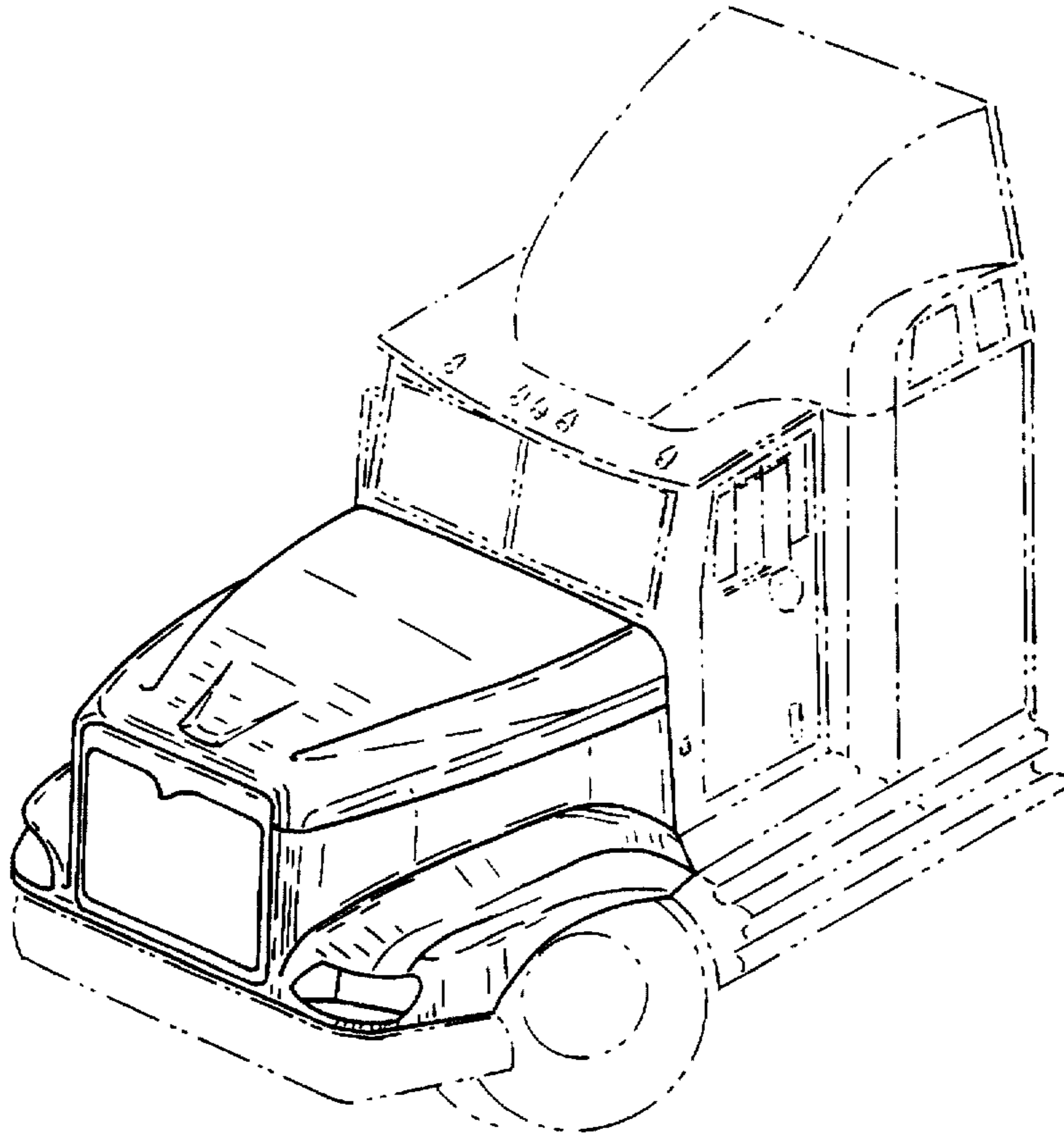

FIG. 1

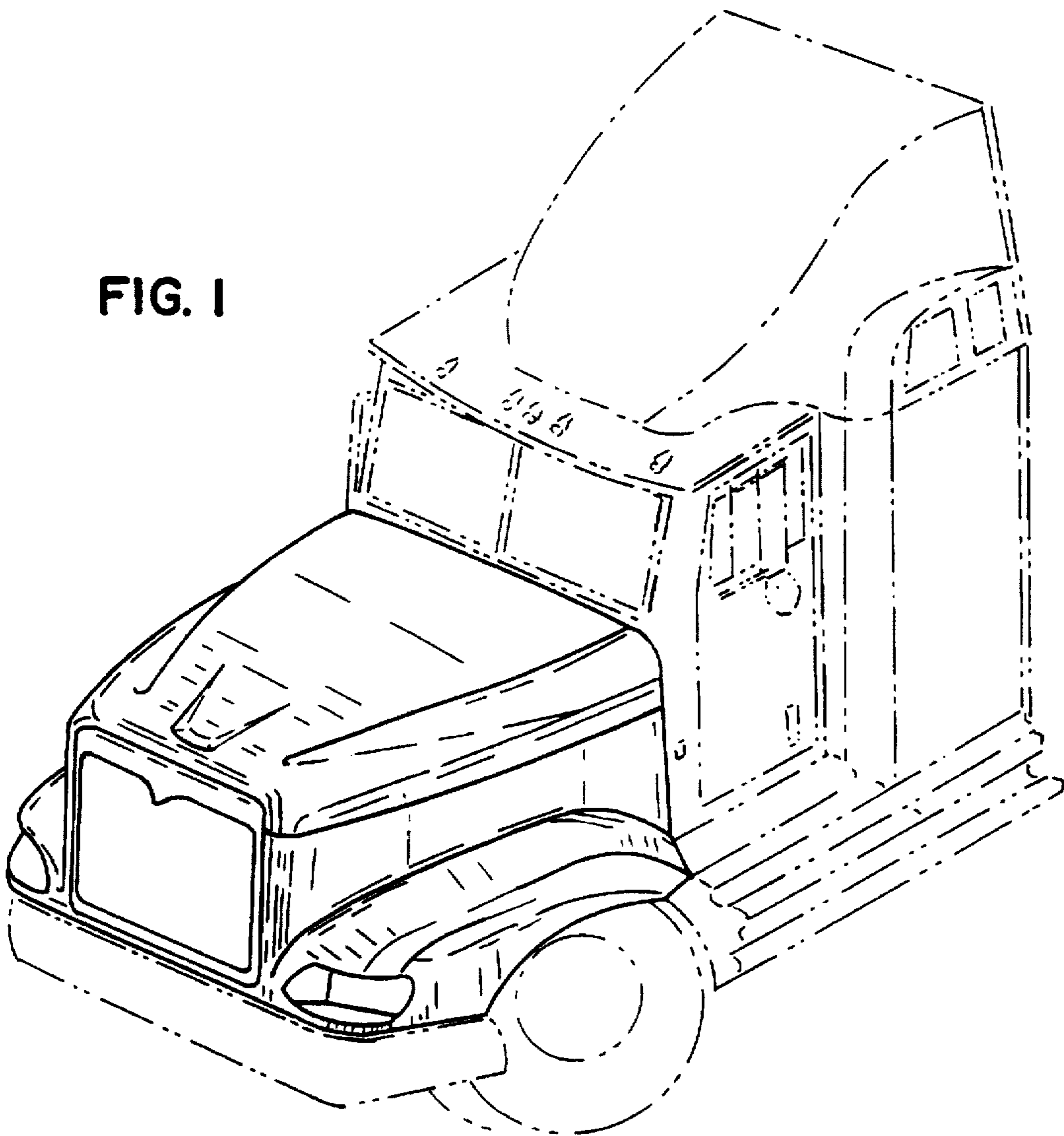

FIG. 2

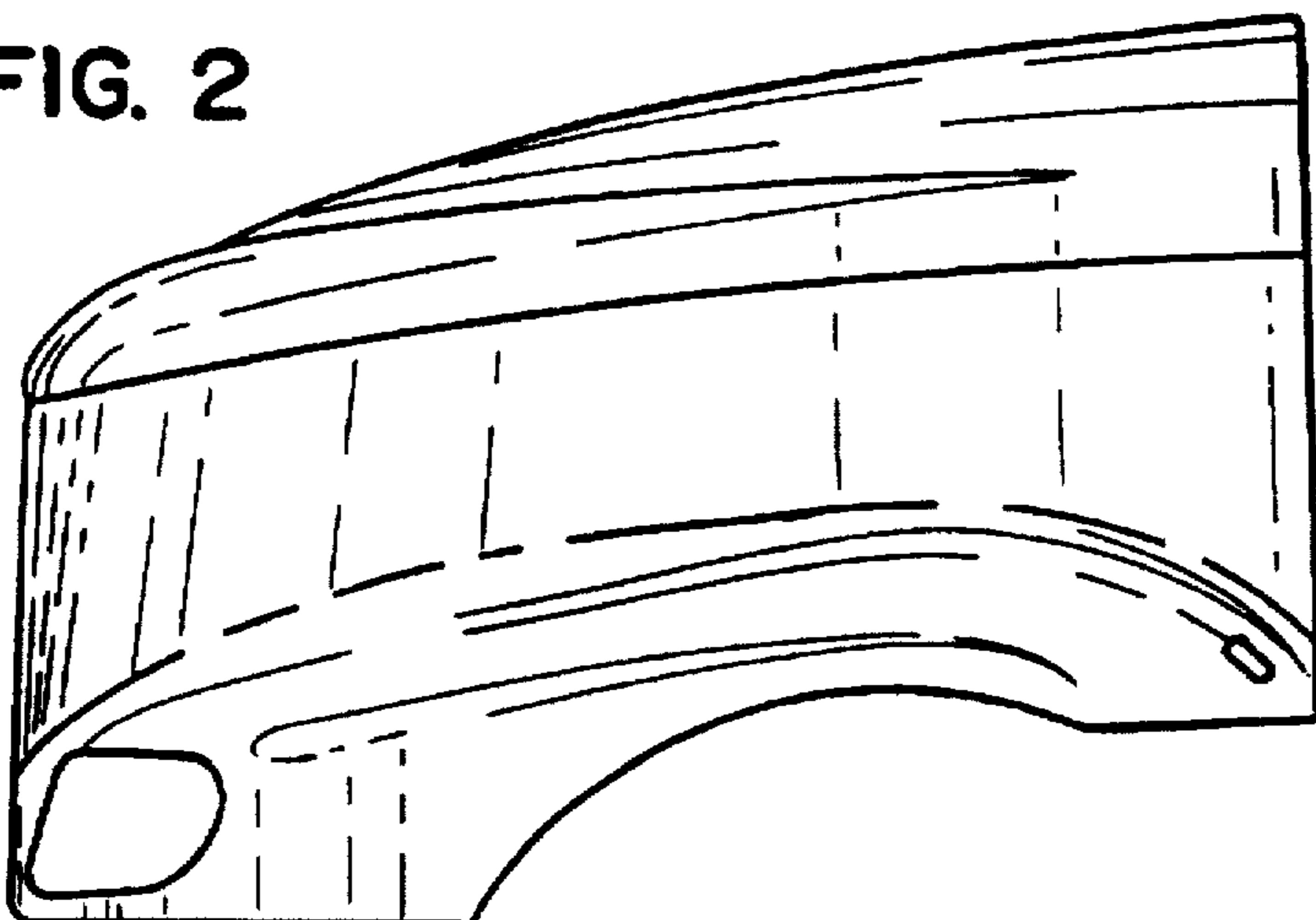

FIG. 3

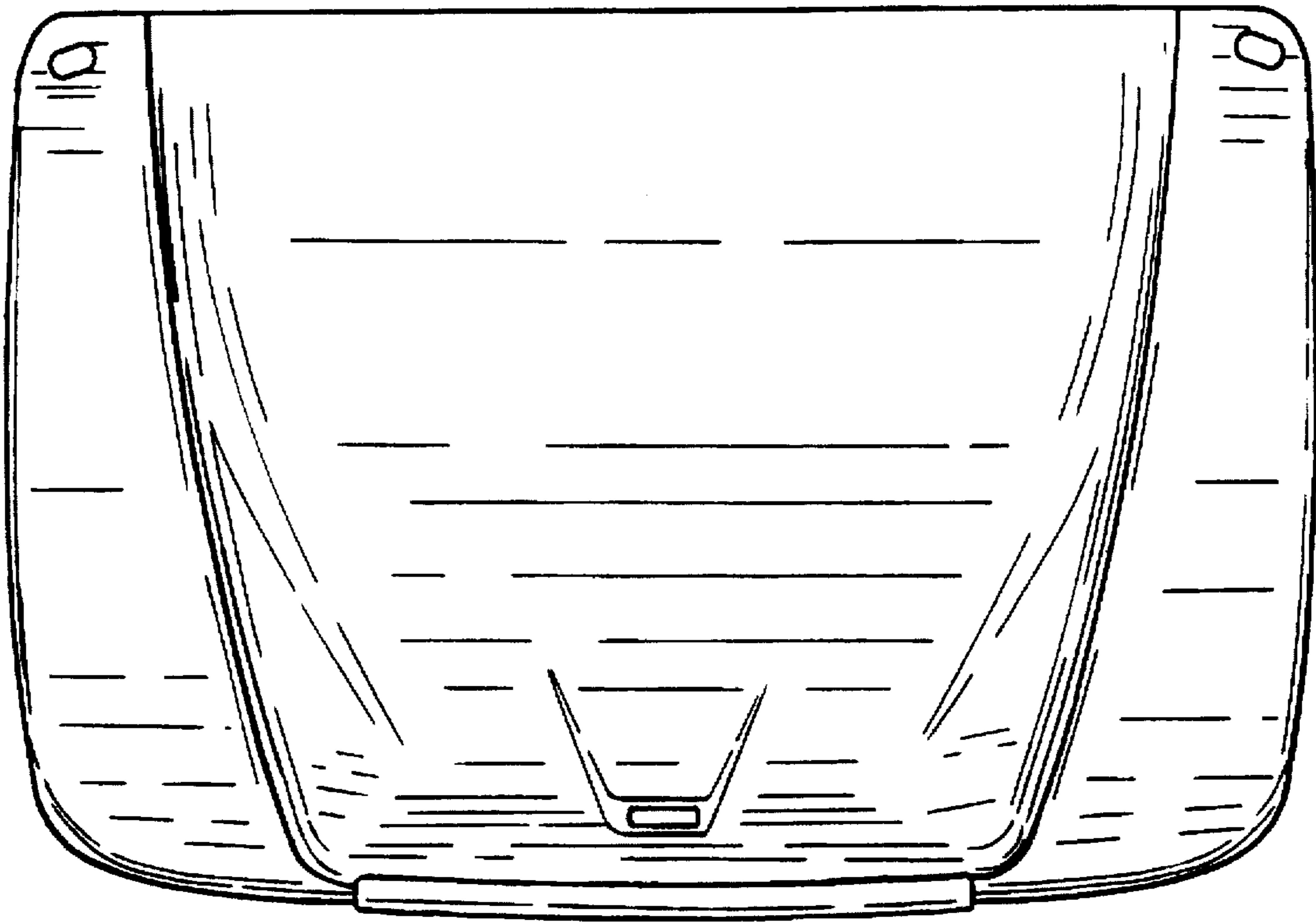

FIG. 4

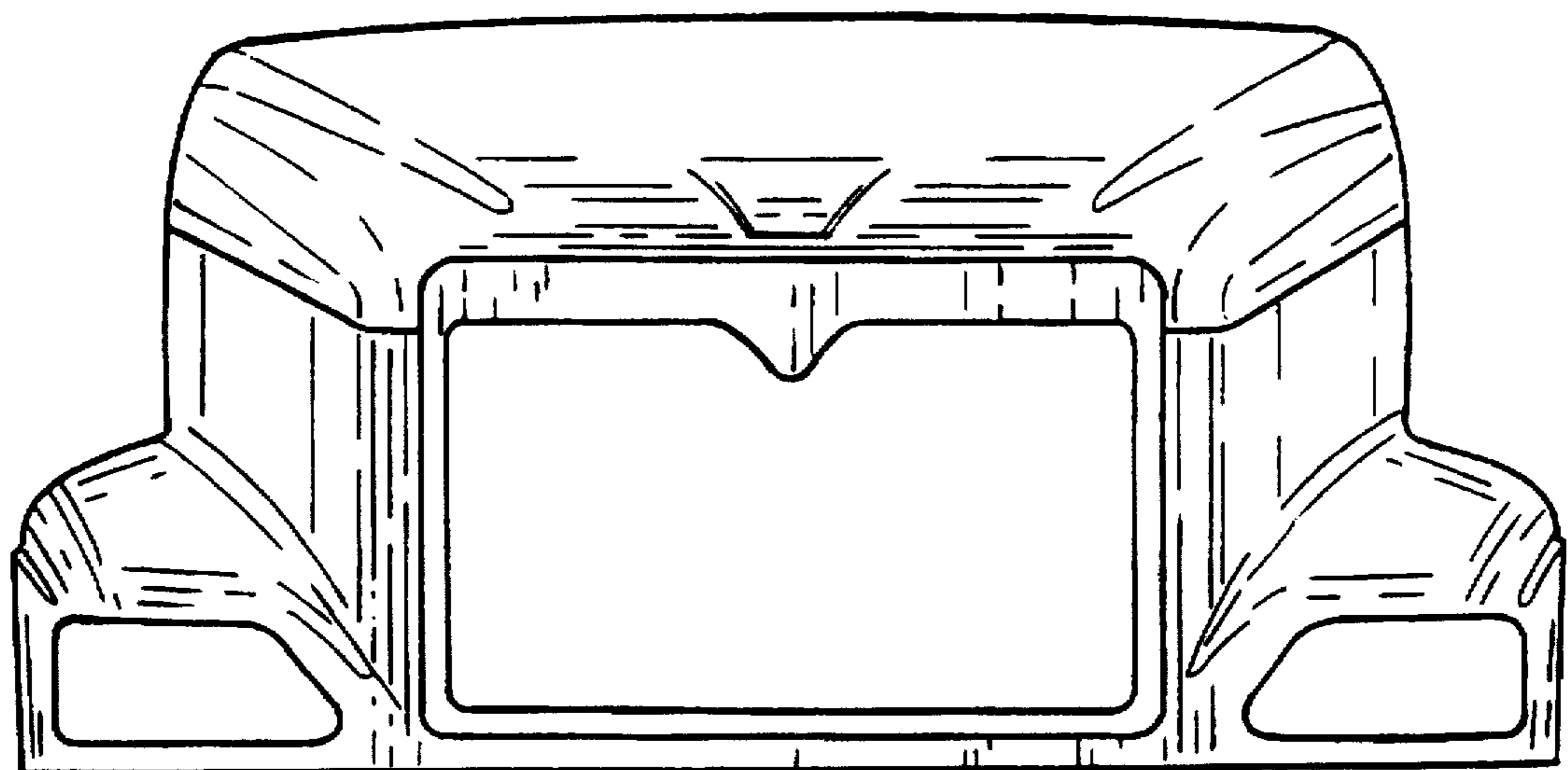

FIG. 5

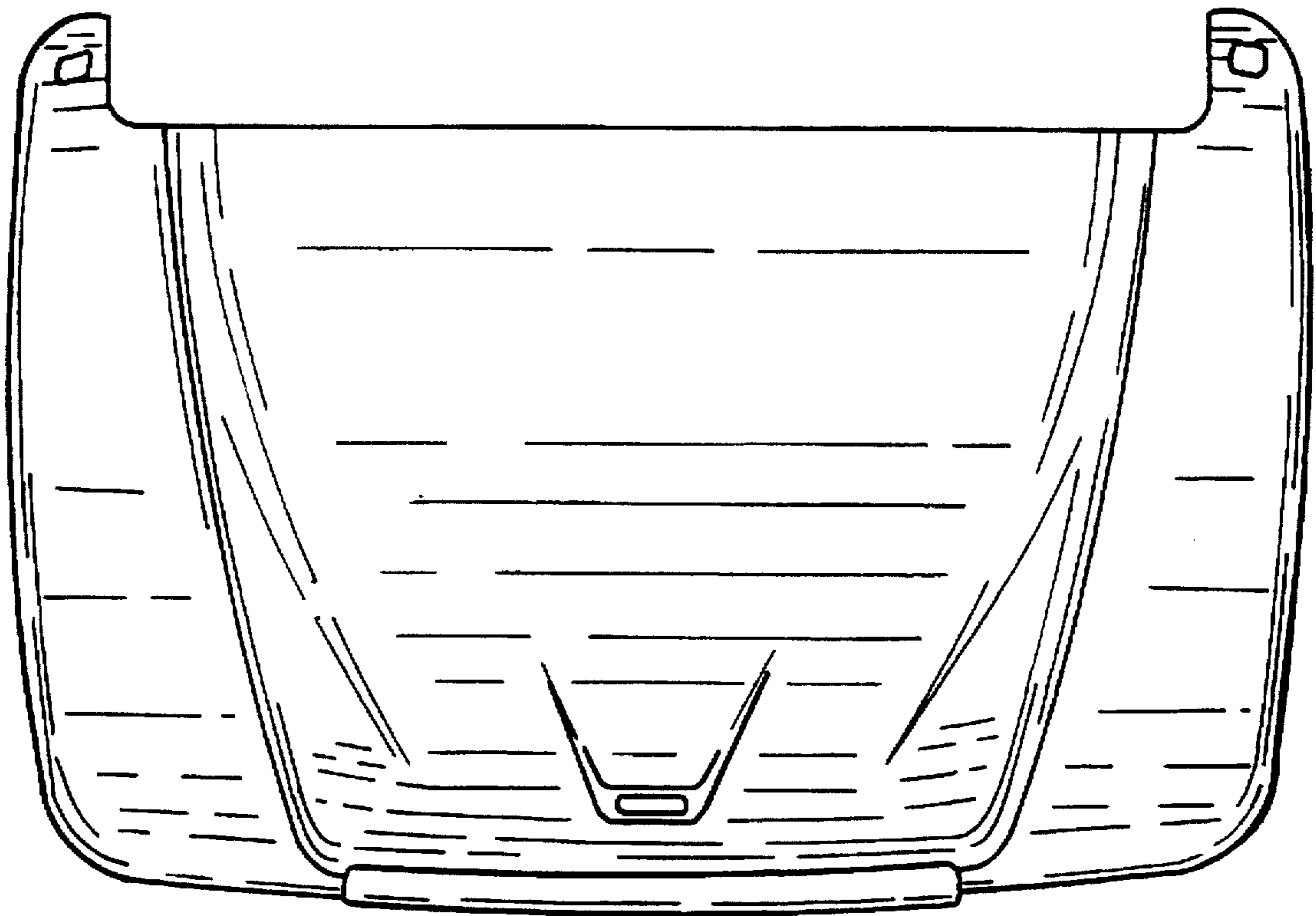

FIG. 6

