



US00D391901S

United States Patent [19]
Forbes-Robinson

[11] **Patent Number: Des. 391,901**
[45] **Date of Patent: **Mar. 10, 1998**

[54] **AUTOMOBILE**

[75] **Inventor: Elliott Forbes-Robinson**, Sherrills Ford, N.C.

[73] **Assignee: 600 Racing, Inc.**, Concord, N.C.

[**] **Term: 14 Years**

[21] **Appl. No.: 66,303**

[22] **Filed: Feb. 11, 1997**

[51] **LOC (6) Cl. 12-08**

[52] **U.S. Cl. D12/92**

[58] **Field of Search D12/86, 90-92;
296/185**

1937 Chevy Coupe, Charlotte Motor Speedway, Charlotte, North Carolina, Apr. 1993.

Hot Rod, 1938 Chevy Sedan, Nov., 1985, p. 53.

Car & Driver Race Cars, Aug. 1992, pp. 150, 152 & 154.

Hot Rod, Oct. 1984, p. 91.

Hot Rod, Nov. 1985, p. 19.

Complete Encyclopedia of Motor Cars, 1939 Mercury Sedan, 1885-68, p. 382.

Hot Rod, 1938 Chevy Coupe, Sep. 1985, pp. 82-83.

Hot Rod, 1937 Ford Coupe, Sep., 1991, p. 53.

Hot Rod, 1939 Ford Coupe, Jul. 1986, p. 75.

Hot Rod, 1937 Ford Coupe, Oct. 1983, p. 29.

Primary Examiner—Melody N. Brown

Attorney, Agent, or Firm—Bell Seltzer Intellectual Property Law Group of Alston & Bird, LLP

[56] **References Cited**

U.S. PATENT DOCUMENTS

- D. 381,294 7/1997 Forbes-Robinson D12/91
- D. 381,937 8/1997 Forbes-Robinson D12/92
- 1,992,496 2/1935 Marmon et al. 296/185 X
- 2,028,184 1/1936 Bergholt 296/185

OTHER PUBLICATIONS

Chevrolet Chronicle, A Pictorial History From 1904 (1991), pp. 71, 72 & 73.

Ford, The Complete History (1990, pp. 122, 124 and 125.

1937 Ford Coupe, Daytona International Speedway, Daytona, Florida, Feb. 1993.

1937 Ford Sedan, Charlotte Motor Speedway, Charlotte, North Carolina, Mar. 1993.

[57] **CLAIM**

The ornamental design for an automobile, as shown and described.

DESCRIPTION

FIG. 1 is a front perspective view of an automobile showing our new design;

FIG. 2 is a left side elevational view thereof;

FIG. 3 is a top plan view thereof;

FIG. 4 is a right side elevational view thereof;

FIG. 5 is a front elevational view thereof; and,

FIG. 6 is a rear elevational view thereof.

1 Claim, 2 Drawing Sheets

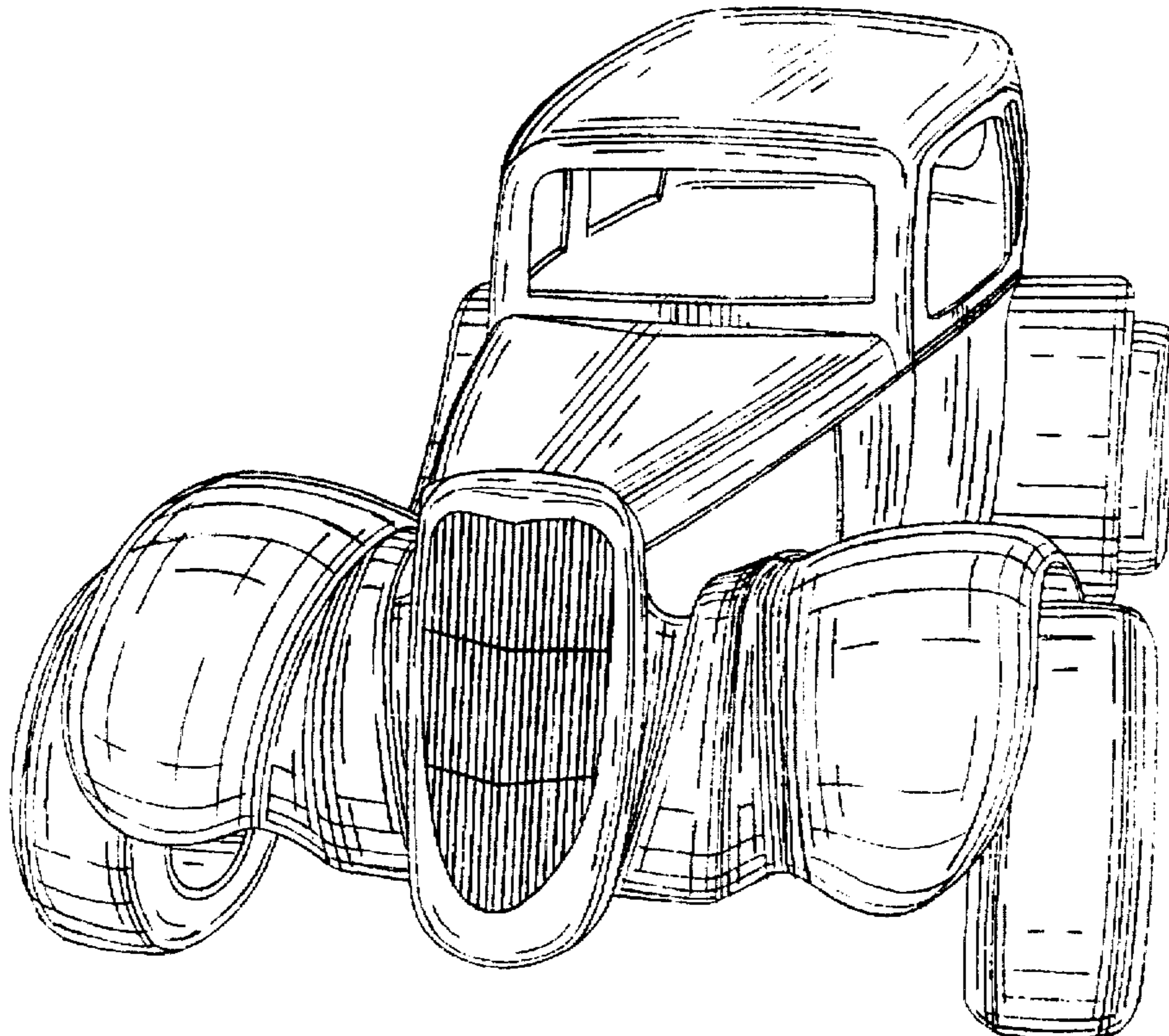

FIG. 1.

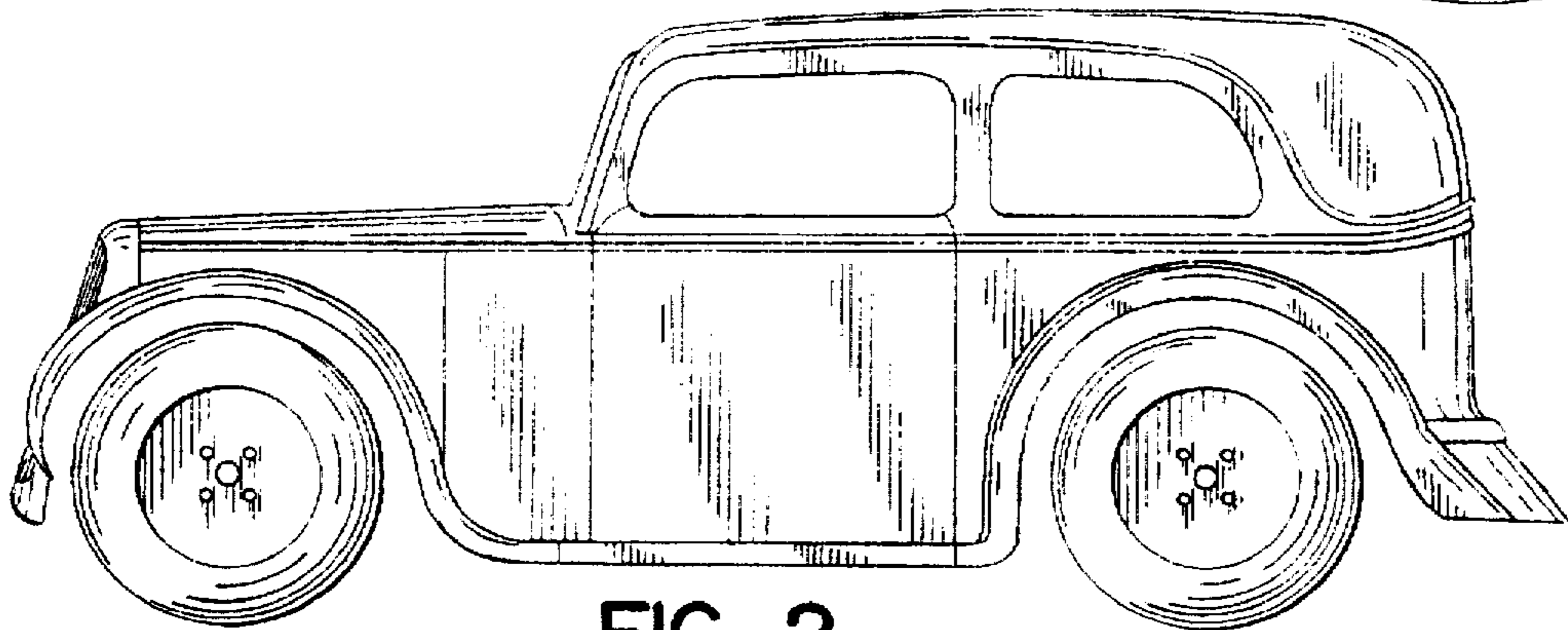
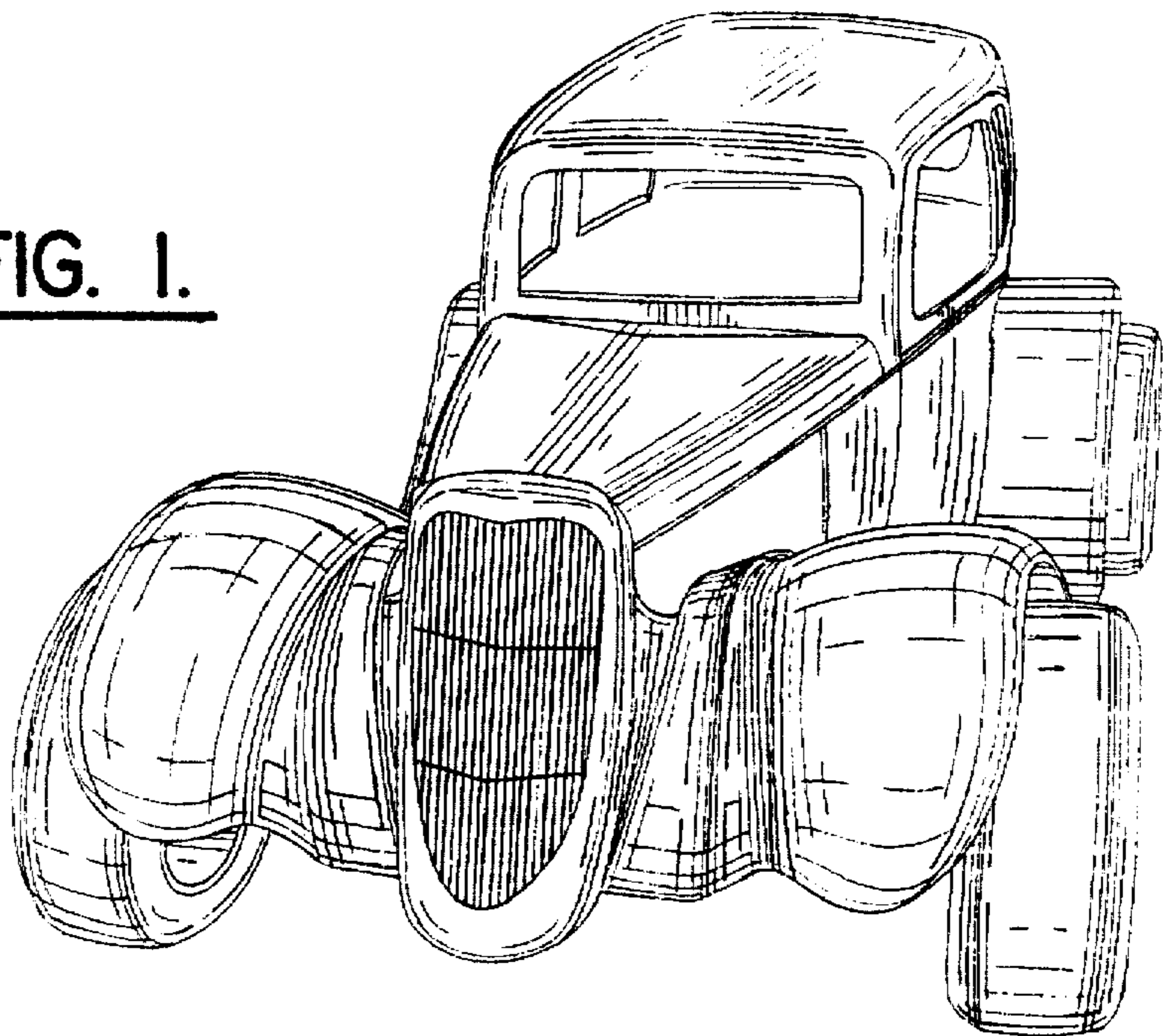

FIG. 2.

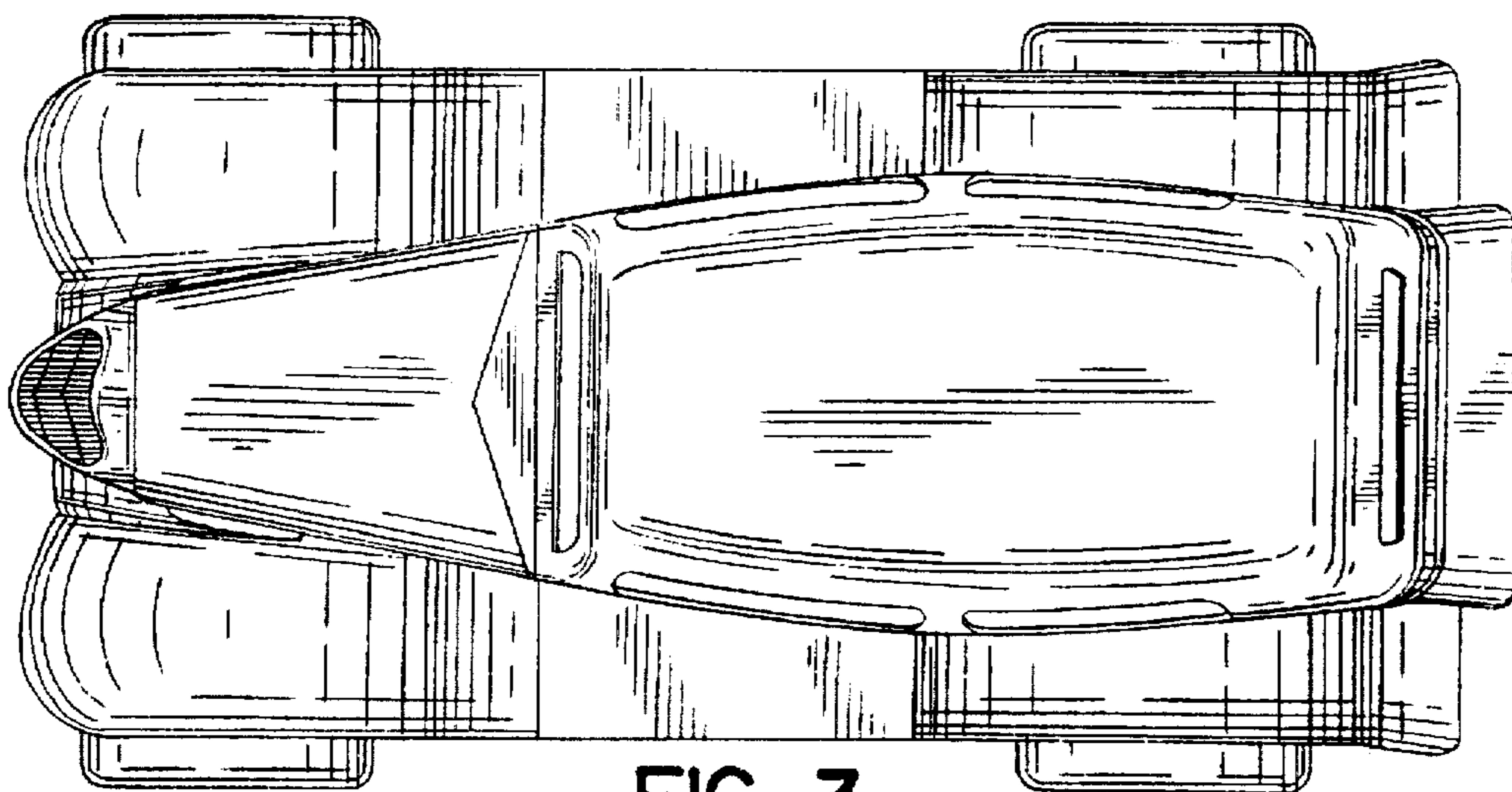

FIG. 3.

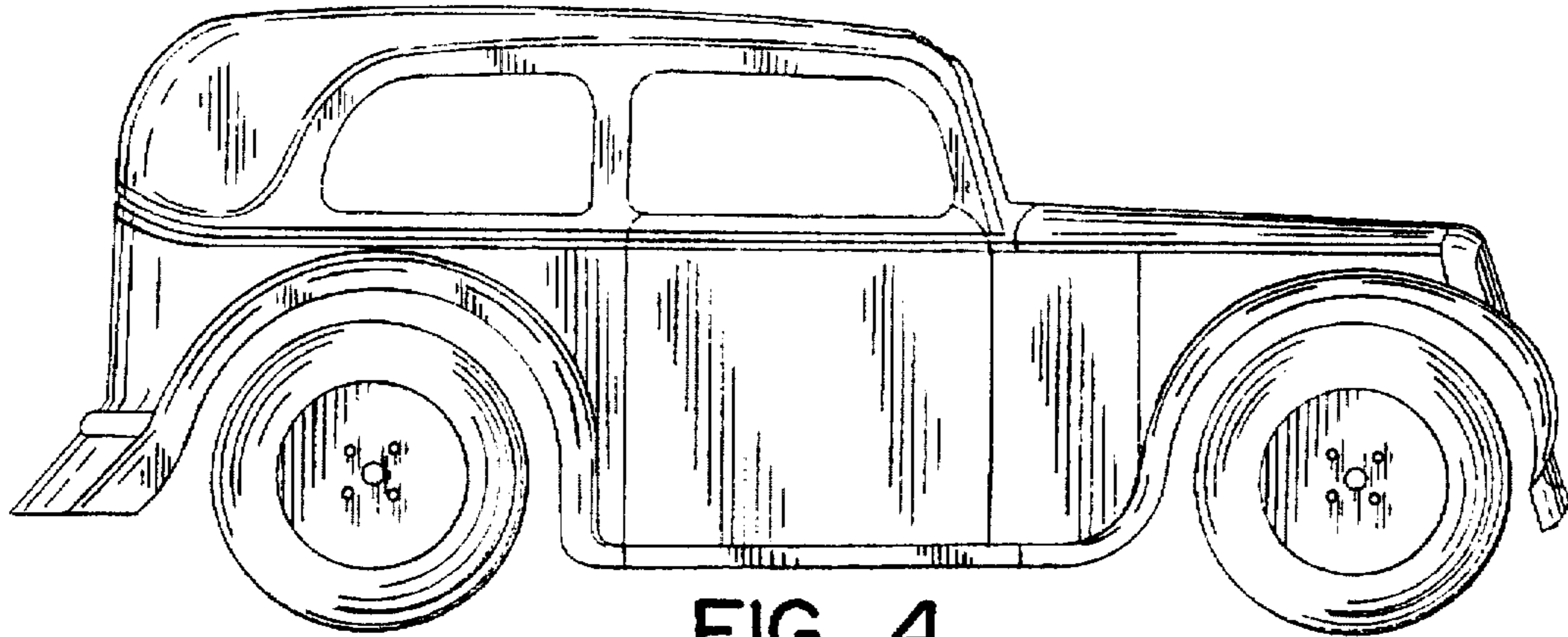

FIG. 4.

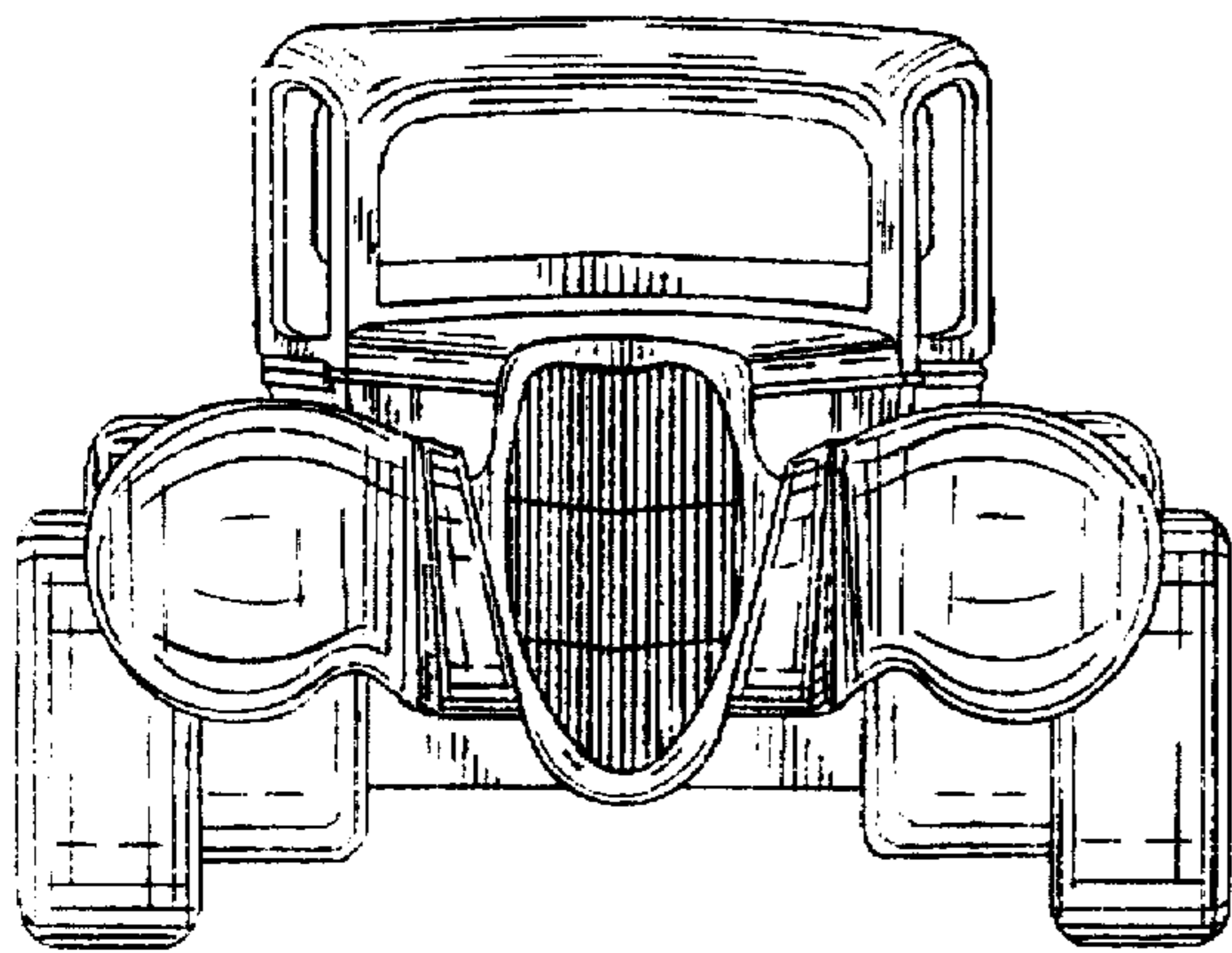

FIG. 5.

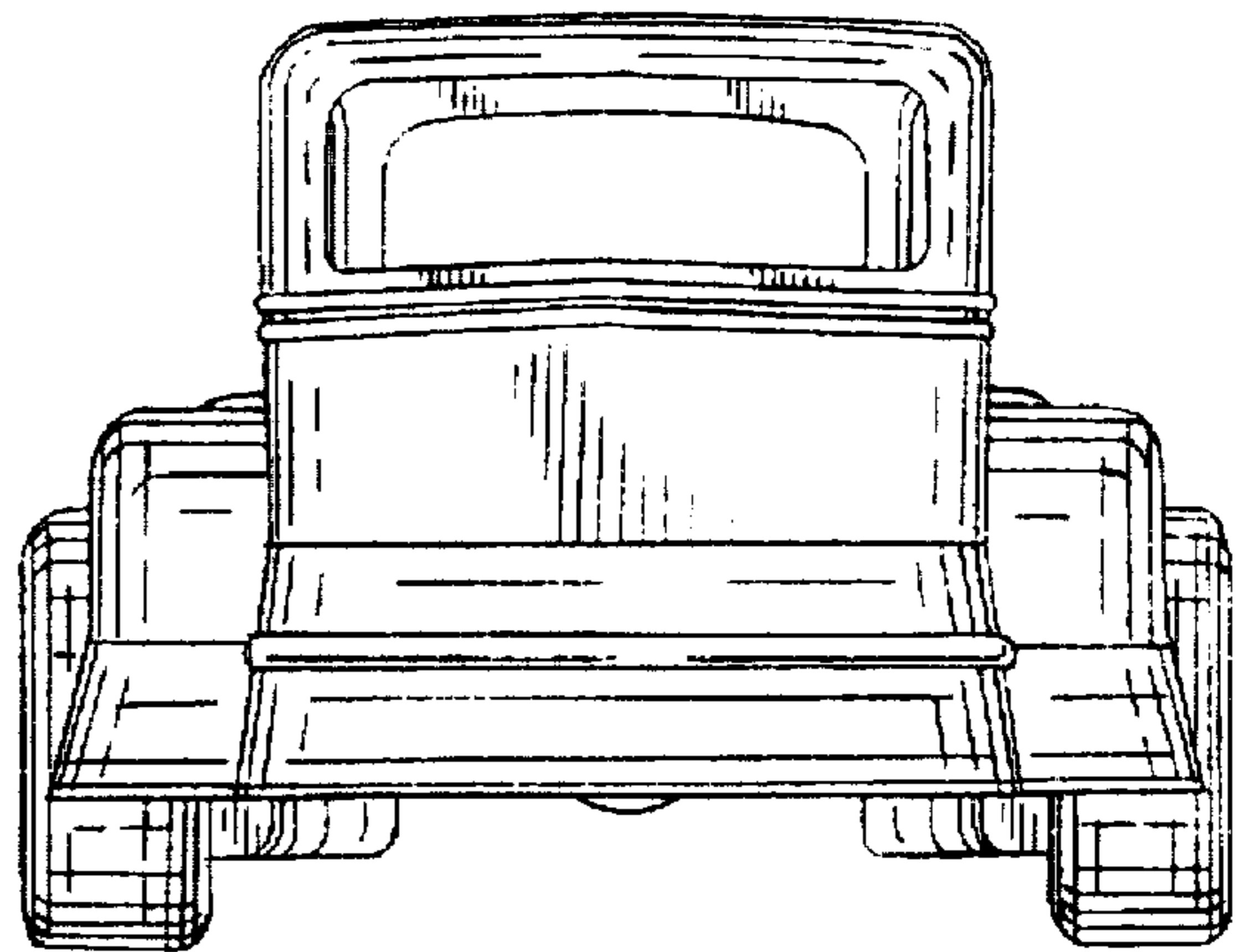

FIG. 6.