



US00D391896S

United States Patent [19]
Albertson

[11] **Patent Number: Des. 391,896**

[45] **Date of Patent: **Mar. 10, 1998**

[54] **TRACK VEHICLE**

[76] **Inventor: David V. Albertson, 3124 Brooks La.,
Minnetonka Beach, Minn. 55361**

[**] **Term: 14 Years**

[21] **Appl. No.: 72,105**

[22] **Filed: Jun. 11, 1997**

[51] **LOC (6) Cl. 12-14**

[52] **U.S. Cl. D12/1; D12/3**

[58] **Field of Search D12/1-3, 7, 12,
D12/14; 180/9.1, 182; 280/80.1**

[56] **References Cited**

U.S. PATENT DOCUMENTS

D. 203,257	12/1965	Fox	D12/3
D. 217,446	5/1970	Mitchell	D12/3
D. 236,703	9/1975	Baker	D12/1
D. 332,764	1/1993	Chandler	D12/3
2,859,068	11/1958	Larsson	D12/3 X
3,474,751	10/1969	Hebert	D12/7

OTHER PUBLICATIONS

Invitation to Snowmobiling—Jan./Feb. 1971—p. 121—
“Ridgerunner ASV.”

Thiokol Chem. Corp.—Sales Sheet—front—Swamp Spryte
#1301—1967.

Primary Examiner—Nelson C. Holtje

[57] **CLAIM**

The ornamental design of a track vehicle, as shown and
described.

DESCRIPTION

FIG. 1 is a perspective view of the track vehicle of my new
design;

FIG. 2 is a side elevational view thereof; the opposite side
being a mirror image thereof;

FIG. 3 is a top plan view thereof;

FIG. 4 is a bottom plan view thereof;

FIG. 5 is a front elevational view thereof; and,

FIG. 6 is a rear elevational view thereof.

1 Claim, 6 Drawing Sheets

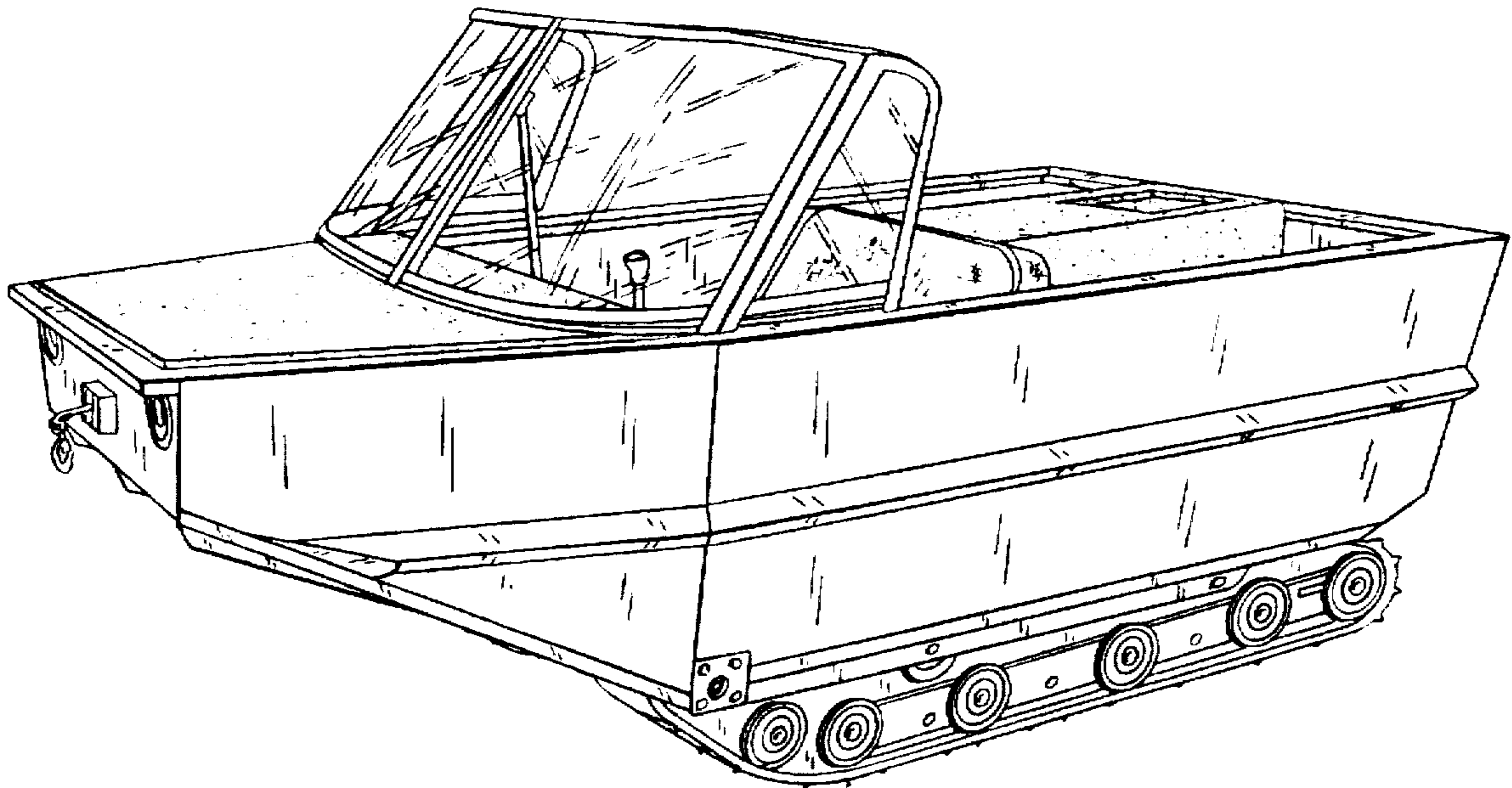

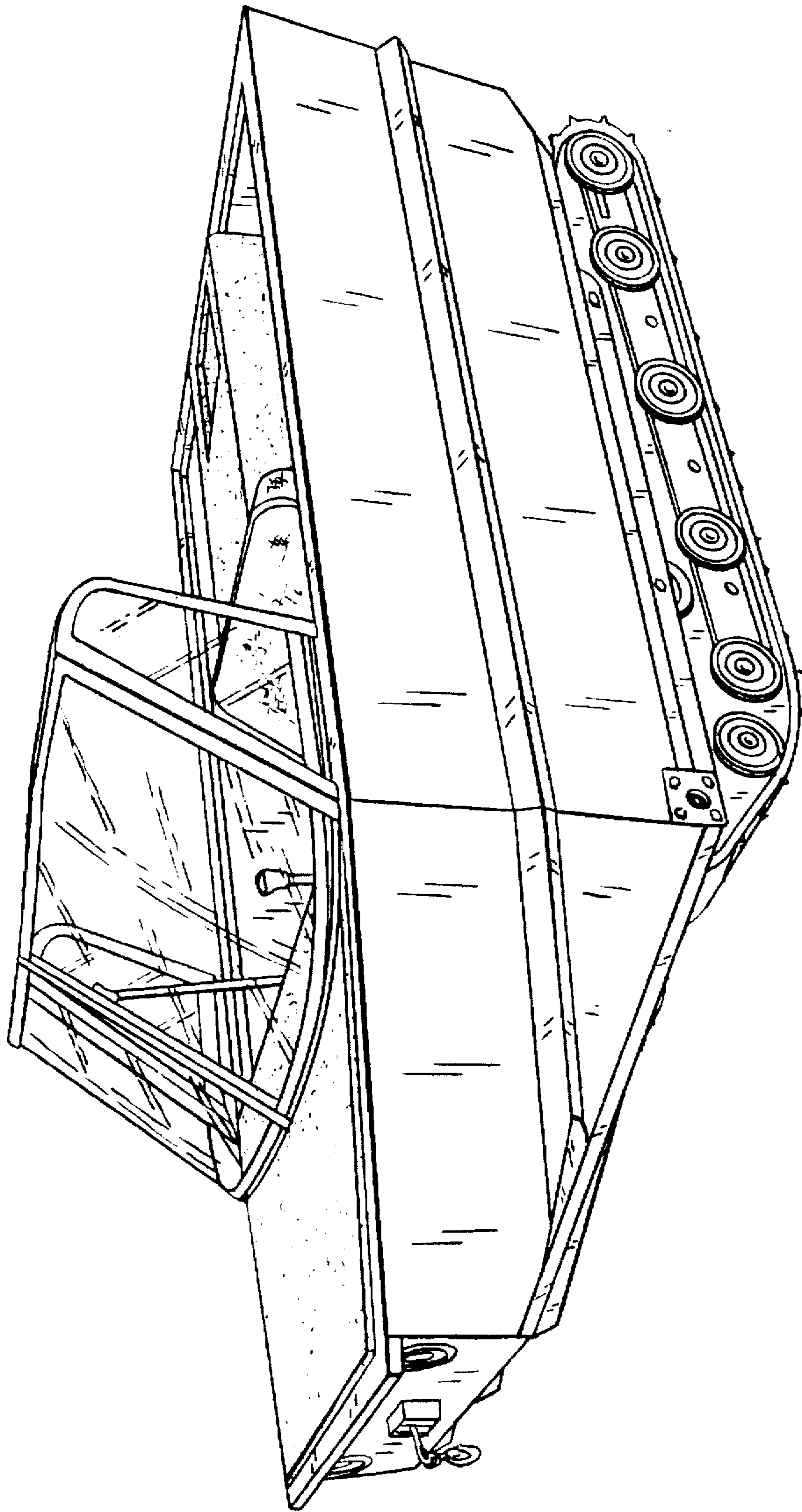

FIG.1

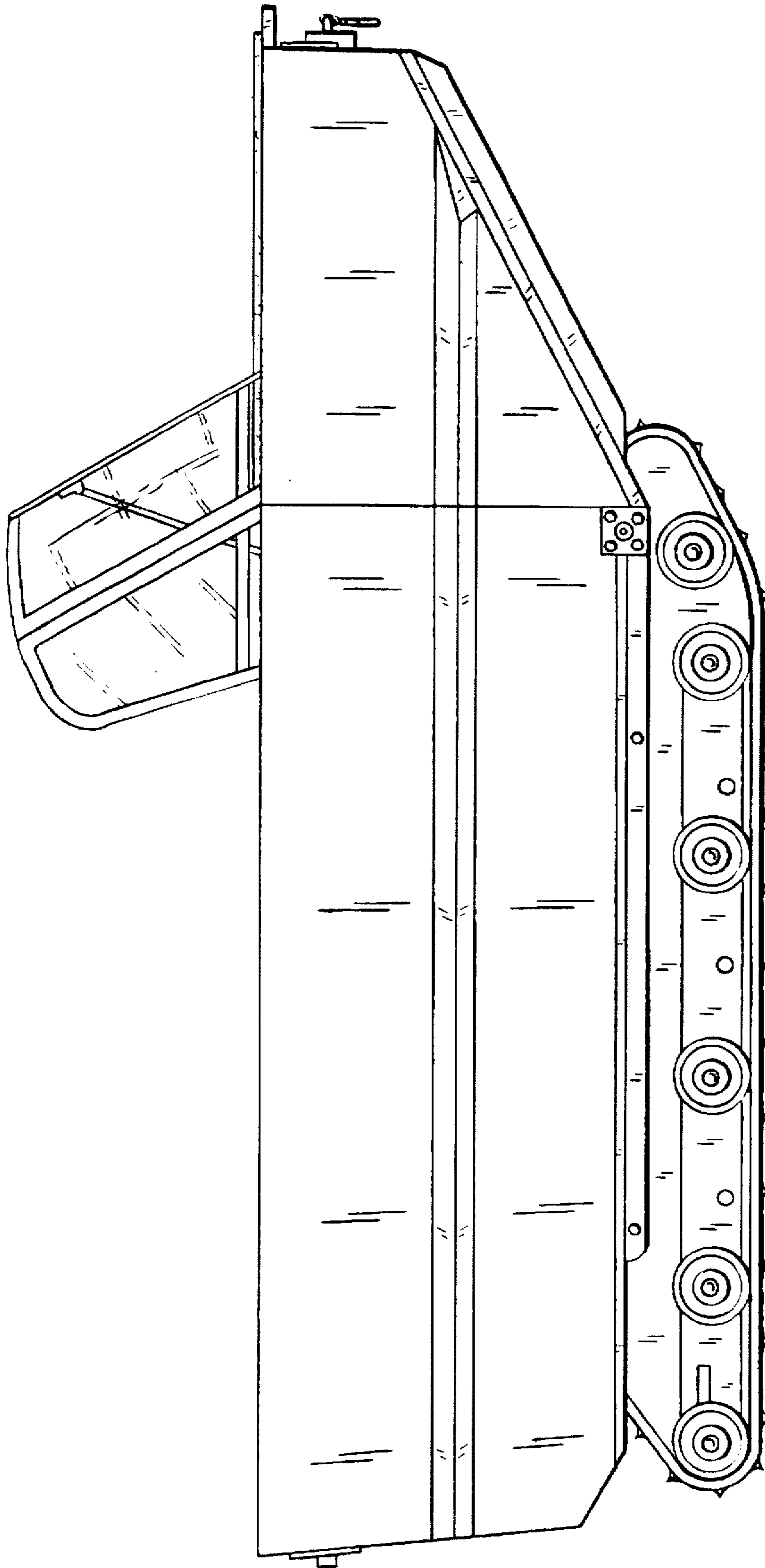

FIG.2

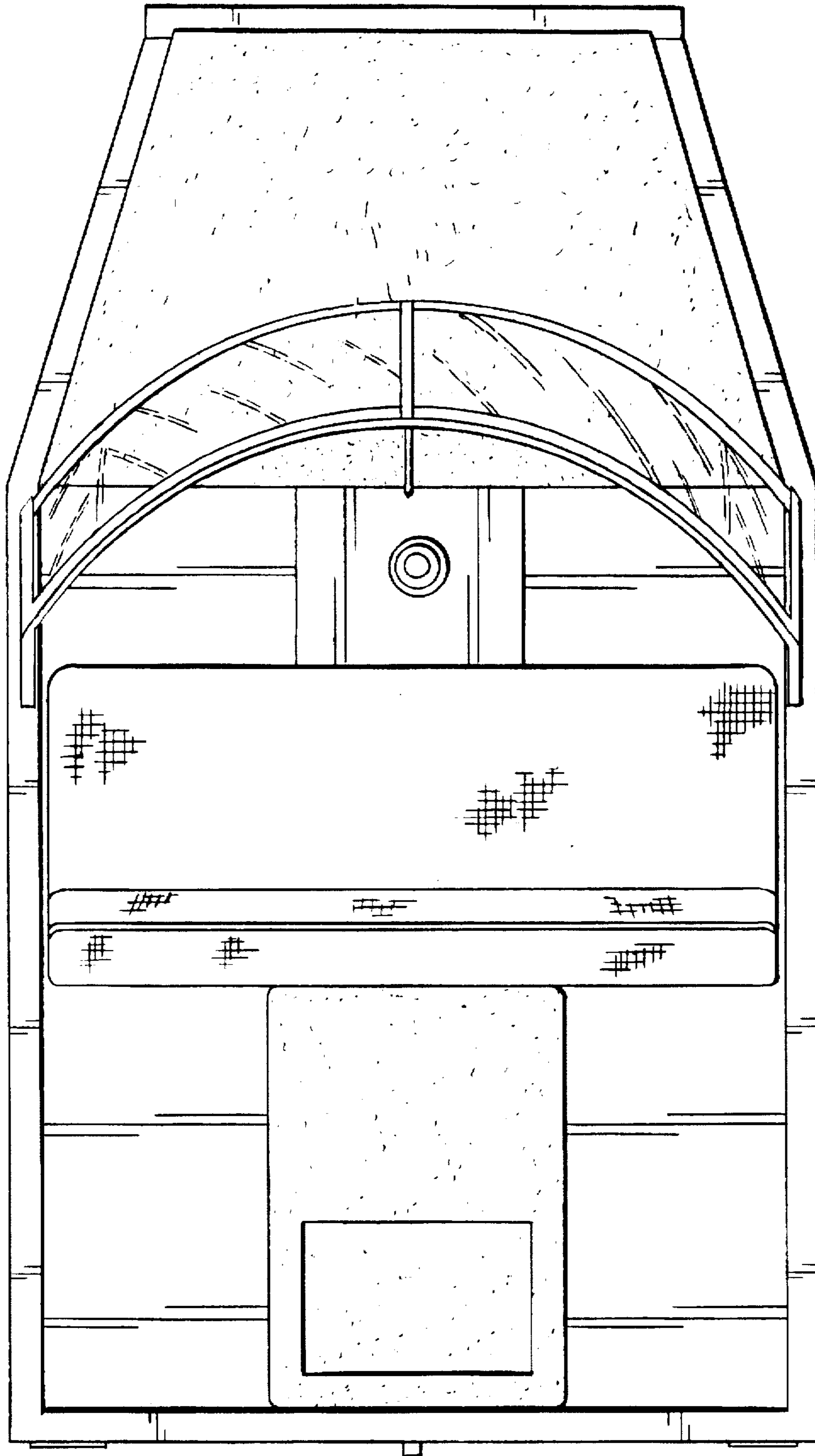

FIG.3

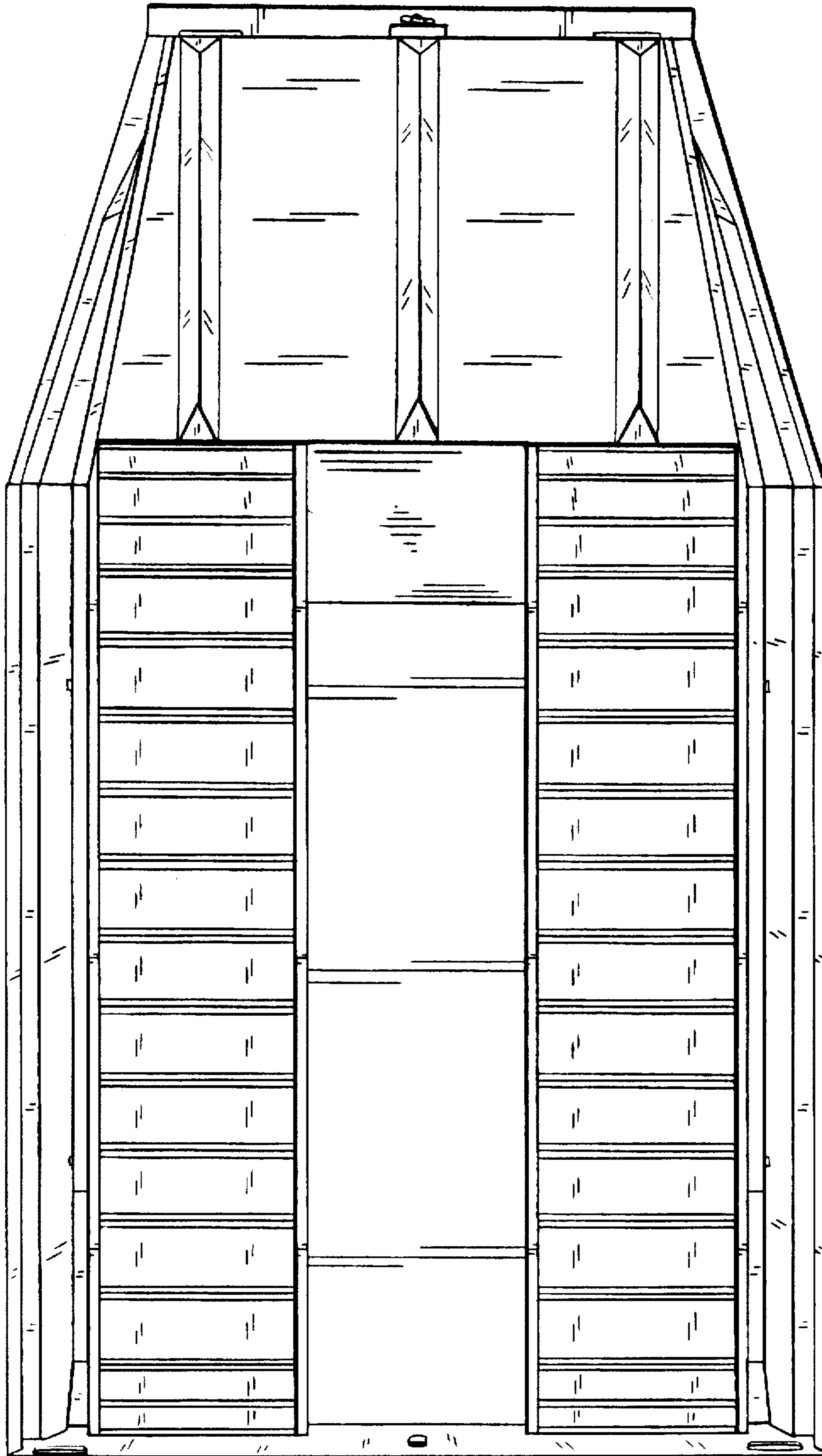

FIG. 4

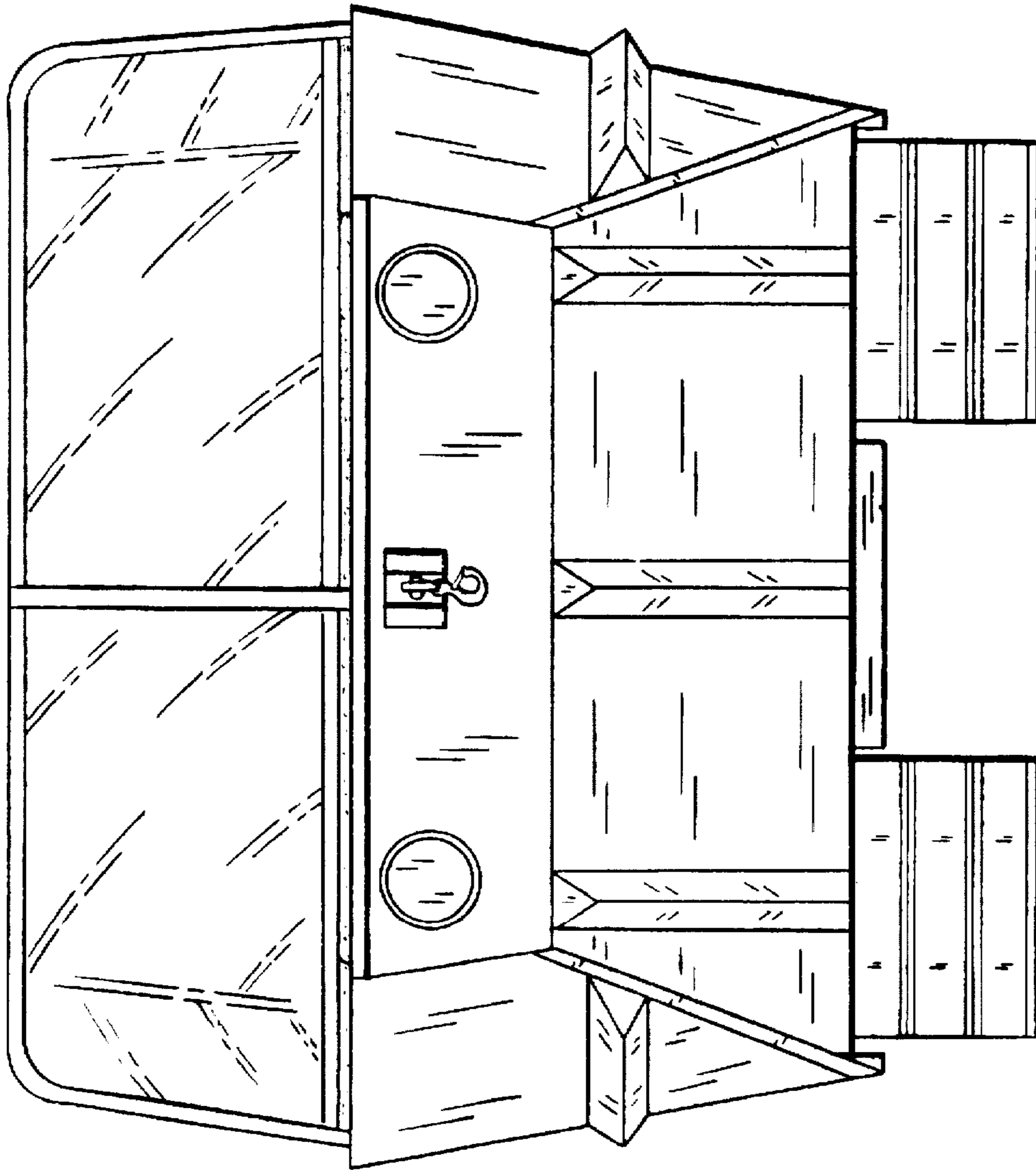

FIG. 5

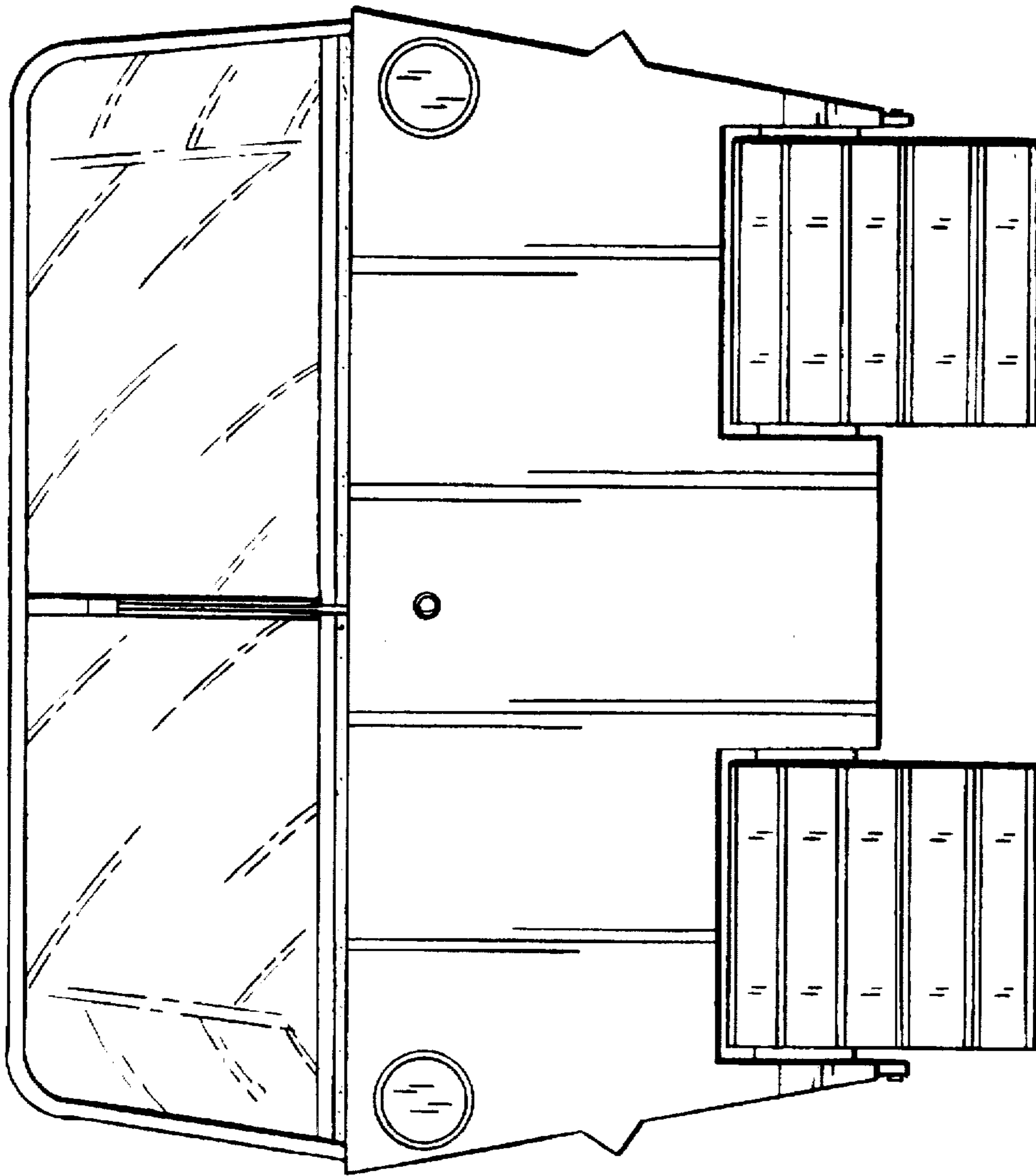

FIG. 6