



US00D391879S

# United States Patent [19]

Lawton

[11] Patent Number: **Des. 391,879**

[45] Date of Patent: **\*\*Mar. 10, 1998**

[54] **EMERGENCY HIGHWAY REFLECTOR**

2,702,955 3/1955 Oliver ..... D10/109  
3,917,232 11/1975 Lindner ..... D10/109

[76] Inventor: **Cal Lawton**, 381 E. 3600 St., Salt Lake City, Utah 84115

*Primary Examiner*—Marcus A. Jackson  
*Attorney, Agent, or Firm*—Harold H. Dutton, Jr.

[\*\*] Term: **14 Years**

[57] **CLAIM**

[21] Appl. No.: **70,595**

The ornamental design for an emergency highway reflector, as shown.

[22] Filed: **May 12, 1997**

**DESCRIPTION**

[51] LOC (6) Cl. .... **10-05**

[52] U.S. Cl. .... **D10/109**

[58] Field of Search ..... D10/104, 109,  
D10/111, 114, 115; D20/10, 40; 116/63 C,  
63 P, 63 T

FIG. 1 is a perspective view of a emergency highway reflector in partially open position showing my new design; FIG. 2 is a front view in fully open position thereof; FIG. 3 is a rear view thereof; FIG. 4 is a side elevational view thereof; FIG. 5 is an opposite side elevational view thereof; FIG. 6 is a top view thereof; and, FIG. 7 is a bottom view thereof.

[56] **References Cited**

**U.S. PATENT DOCUMENTS**

D. 208,739 9/1967 Nunn Jr. .... D10/109  
D. 257,720 12/1980 Rockman ..... D10/109  
1,624,900 4/1927 Parkhurst ..... D10/109

**1 Claim, 4 Drawing Sheets**

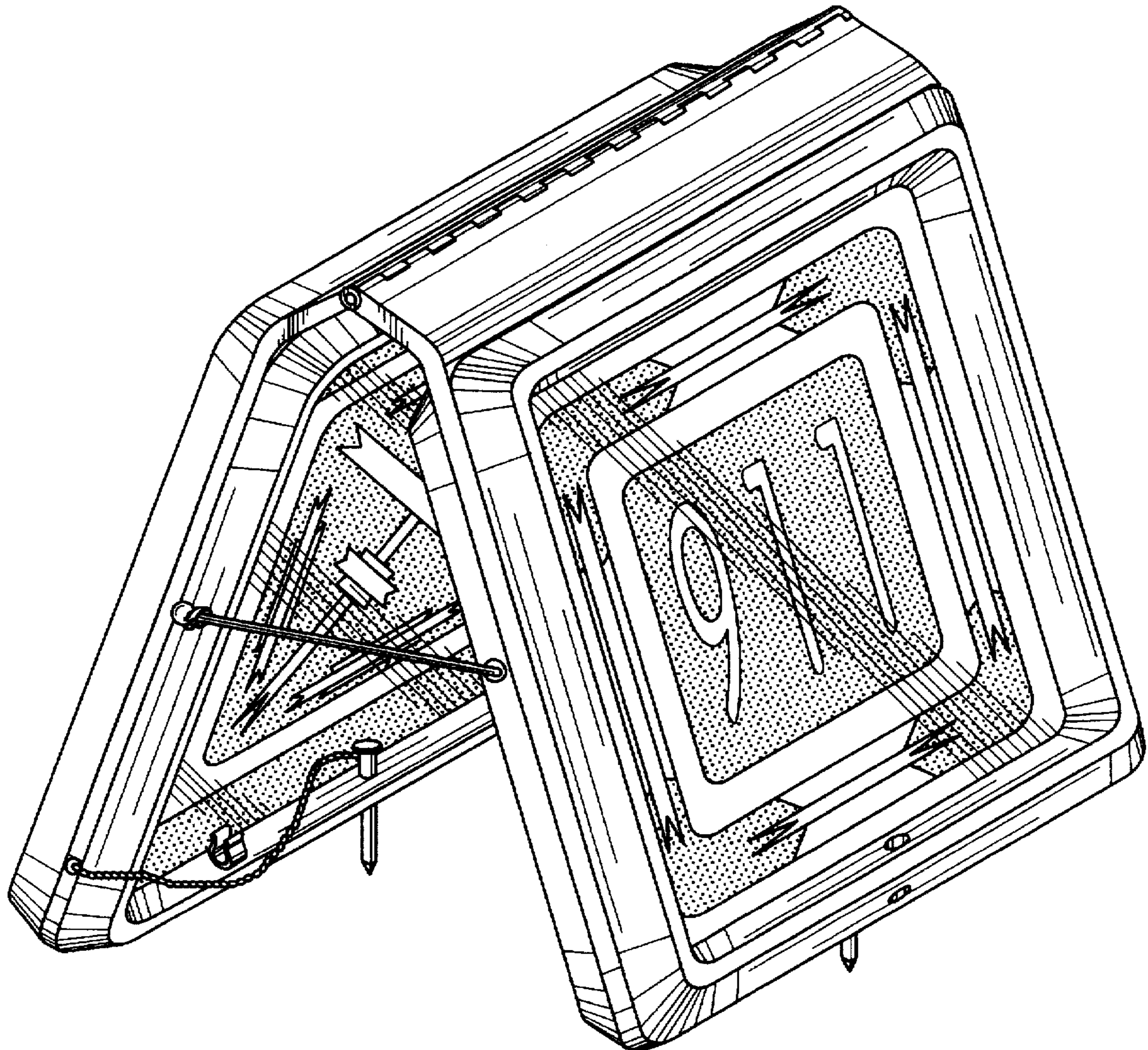

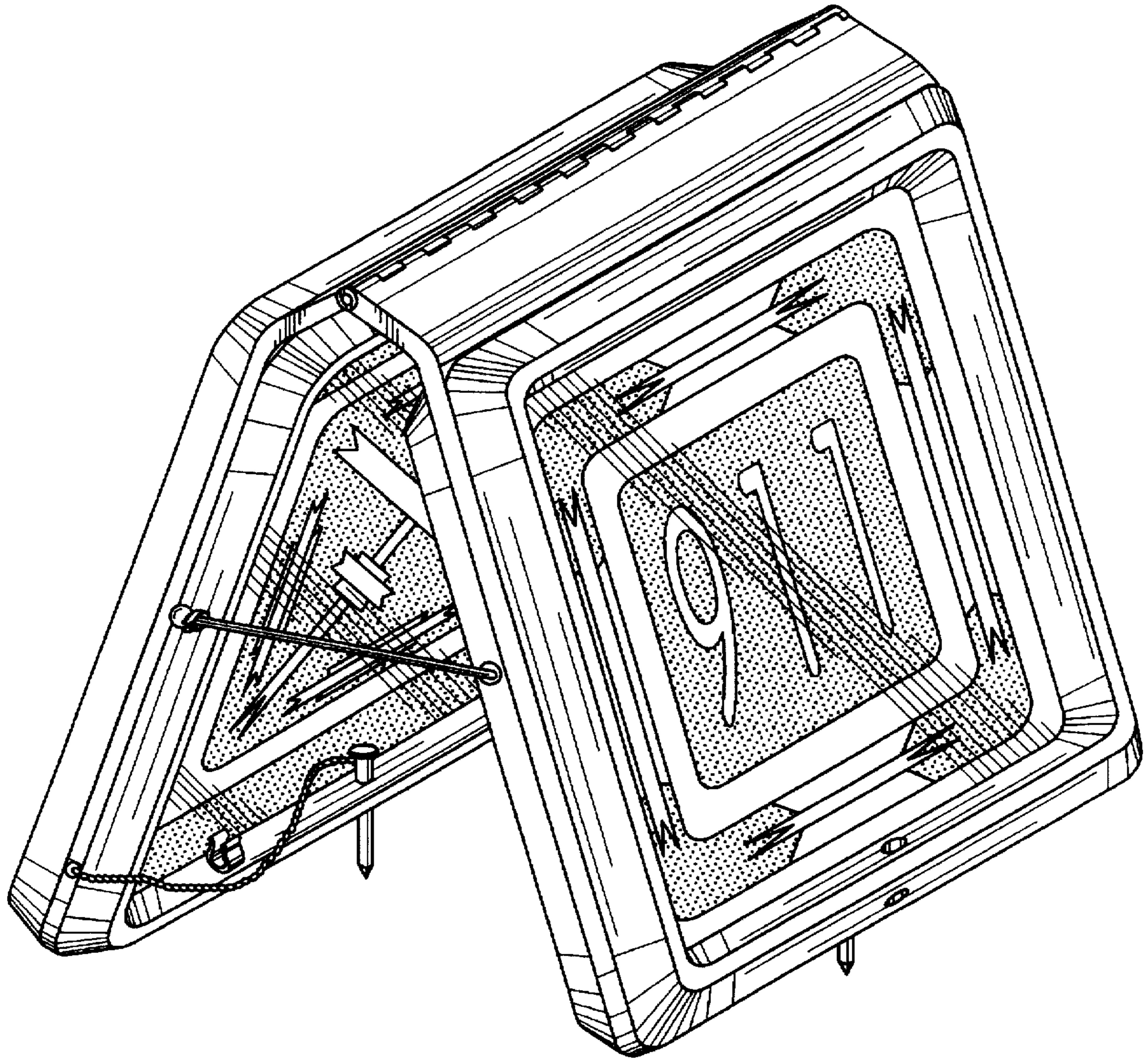

FIG. 1

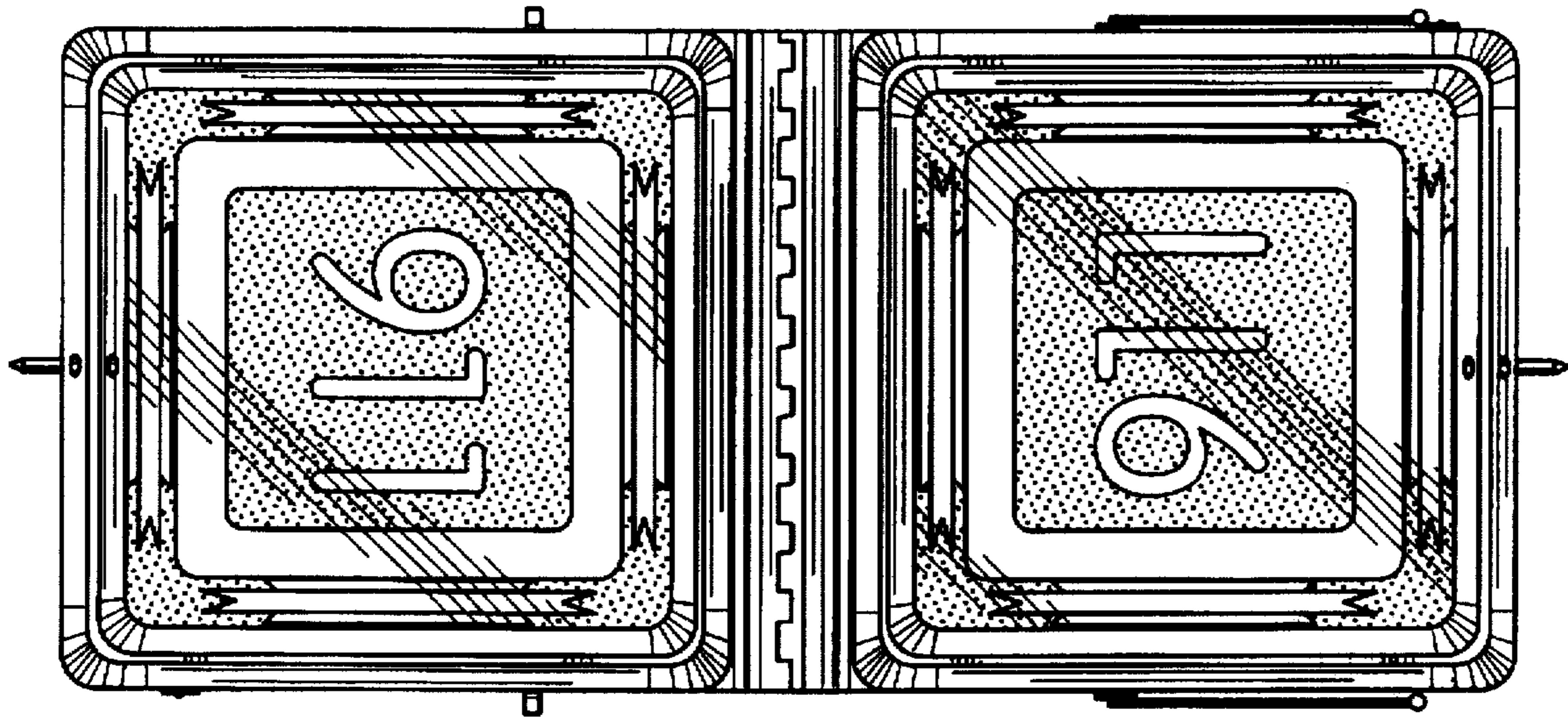

FIG. 2

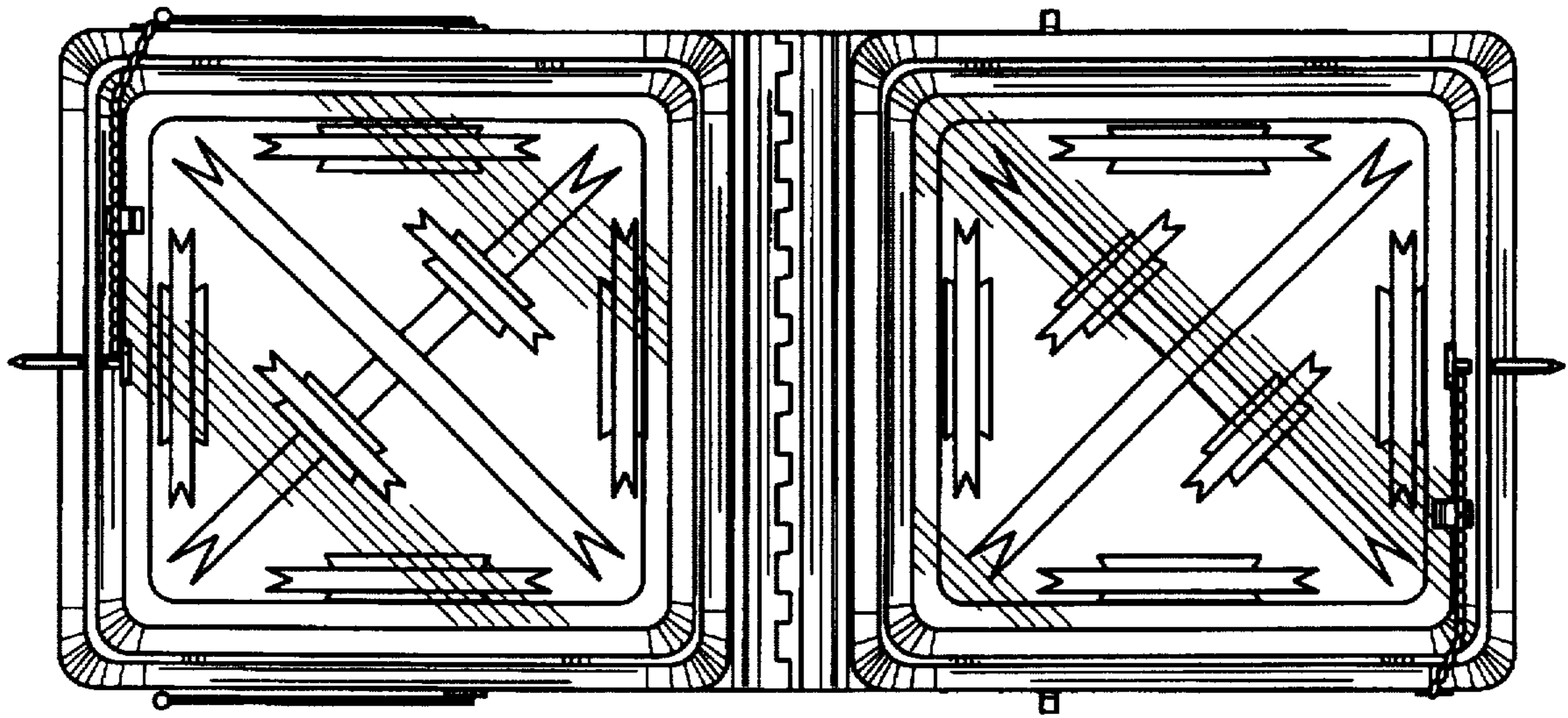

FIG. 3



FIG. 4



FIG. 5



FIG. 6

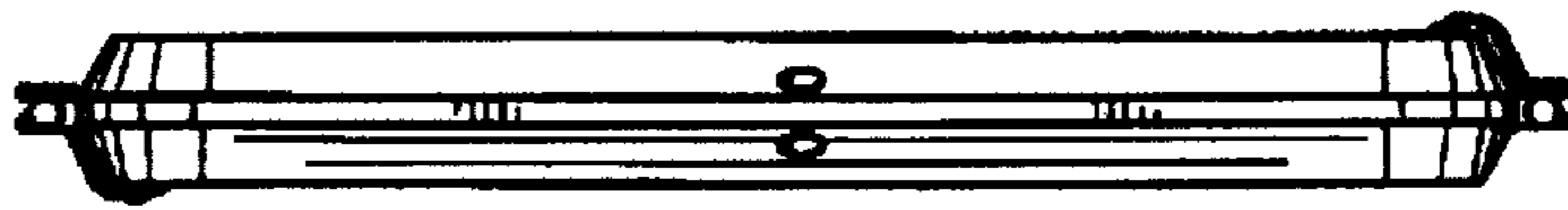

FIG. 7