



US00D391849S

United States Patent [19]

[11] Patent Number: Des. 391,849

Scribner

[45] Date of Patent: **Mar. 10, 1998

[54] TWO PART VEHICLE TRANSMISSION SHIPPING CONTAINER

4,697,699	10/1987	Schneider	206/599 X
5,105,947	4/1992	Wise	206/599 X
5,197,601	3/1993	Sterett	206/386 X

[76] Inventor: Richard L. Scribner, 2483-B Mercantile Dr., Rancho Cordova, Calif. 95742

Primary Examiner—Prabhakar G. Deshmukh
Attorney, Agent, or Firm—Mark C. Jacobs, Esq.

[**] Term: 14 Years

[57] CLAIM

[21] Appl. No.: 64,488

The ornamental design for a two part vehicle transmission shipping container, as shown and described.

[22] Filed: Jan. 2, 1997

DESCRIPTION

[51] LOC (6) Cl. 09-07
 [52] U.S. Cl. D9/426; D9/424
 [58] Field of Search D9/424, 426, 414, D9/432, 337; 206/319, 599, 503, 511, 508; 220/1.5, 4.21, 415, 420, 17.1, 476; D15/5; D3/304

FIG. 1 is a top perspective view of a two part vehicle transmission shipping container showing my new design; FIG. 2 is a top perspective view of the upper portion thereof; FIG. 3 is a bottom perspective view of the upper portion thereof; FIG. 4 is a bottom perspective view of the lower portion thereof; FIG. 5 is a top perspective view of the lower portion thereof; and, FIG. 6 is a bottom plan view of the upper portion of the first embodiment.

[56] References Cited

U.S. PATENT DOCUMENTS

D. 258,203	2/1981	Elzea et al.	D9/426
2,843,258	7/1958	Boeye	206/319
3,785,534	1/1974	Smith	206/599 X
4,114,754	9/1978	Aley	206/319
4,678,084	7/1987	Maker et al.	206/599 X

The upper and lower portions of the design are shown separately in FIGS. 2-6 for clarity of illustration.

1 Claim, 3 Drawing Sheets

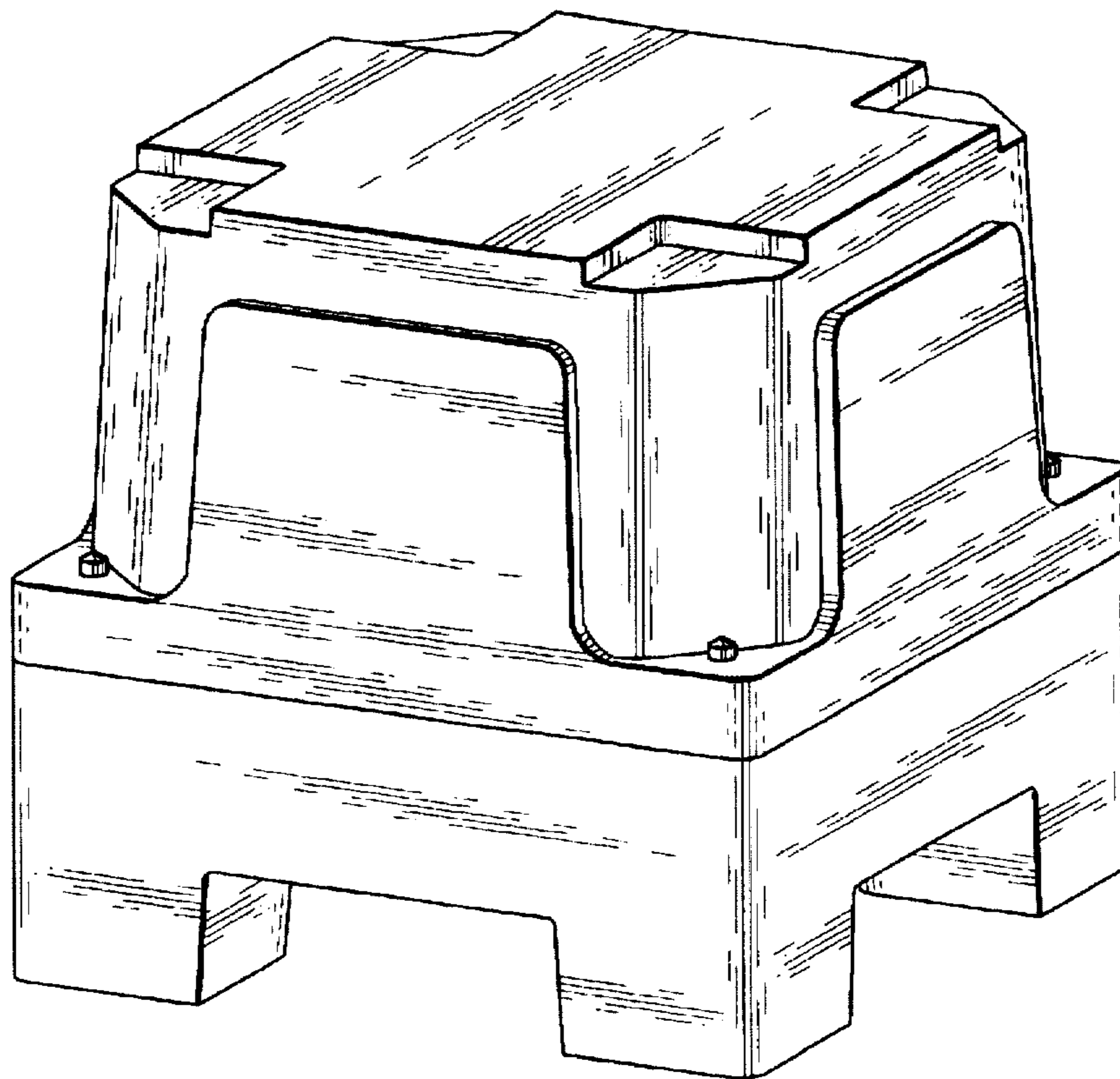

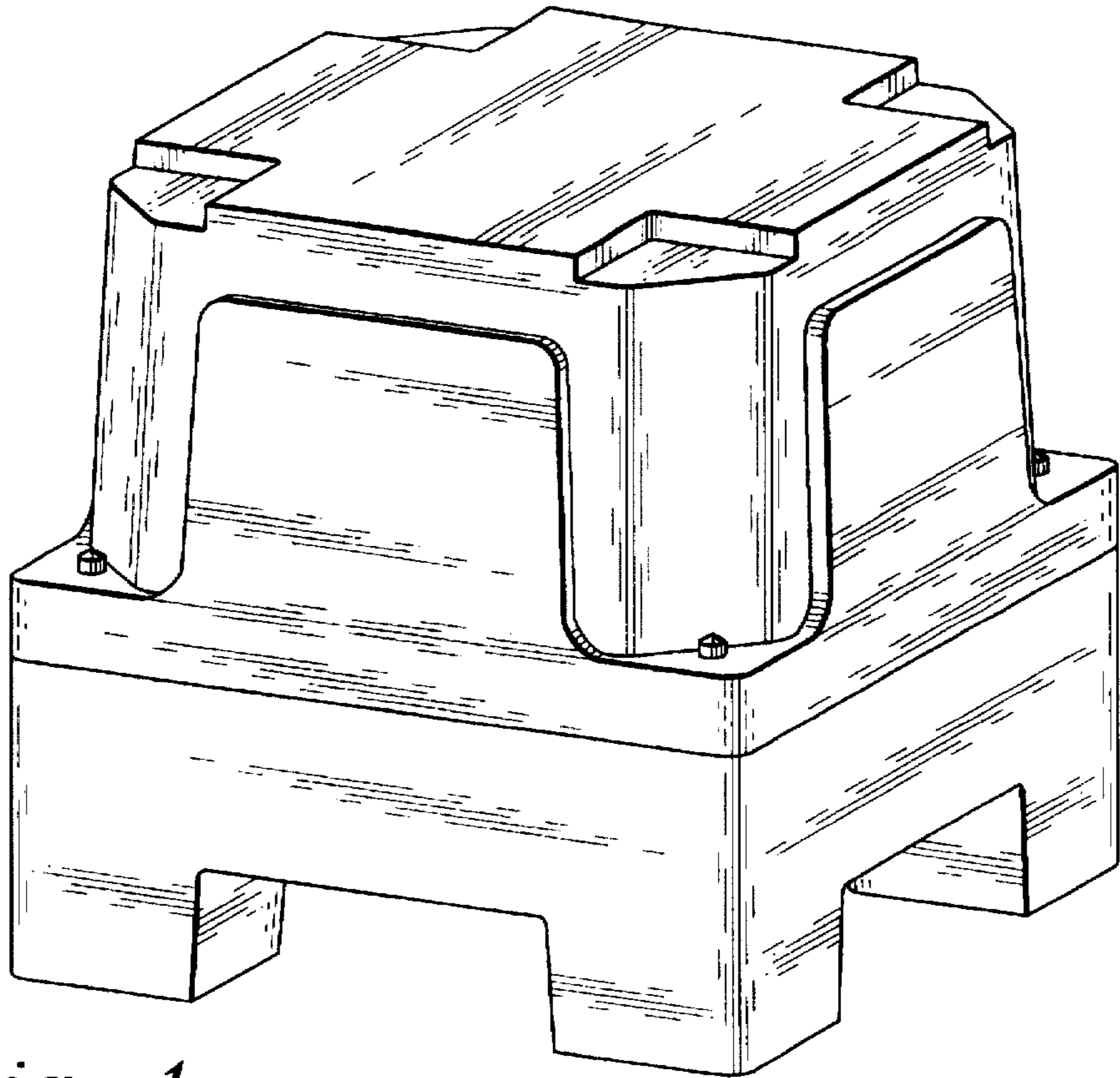

Fig. 1

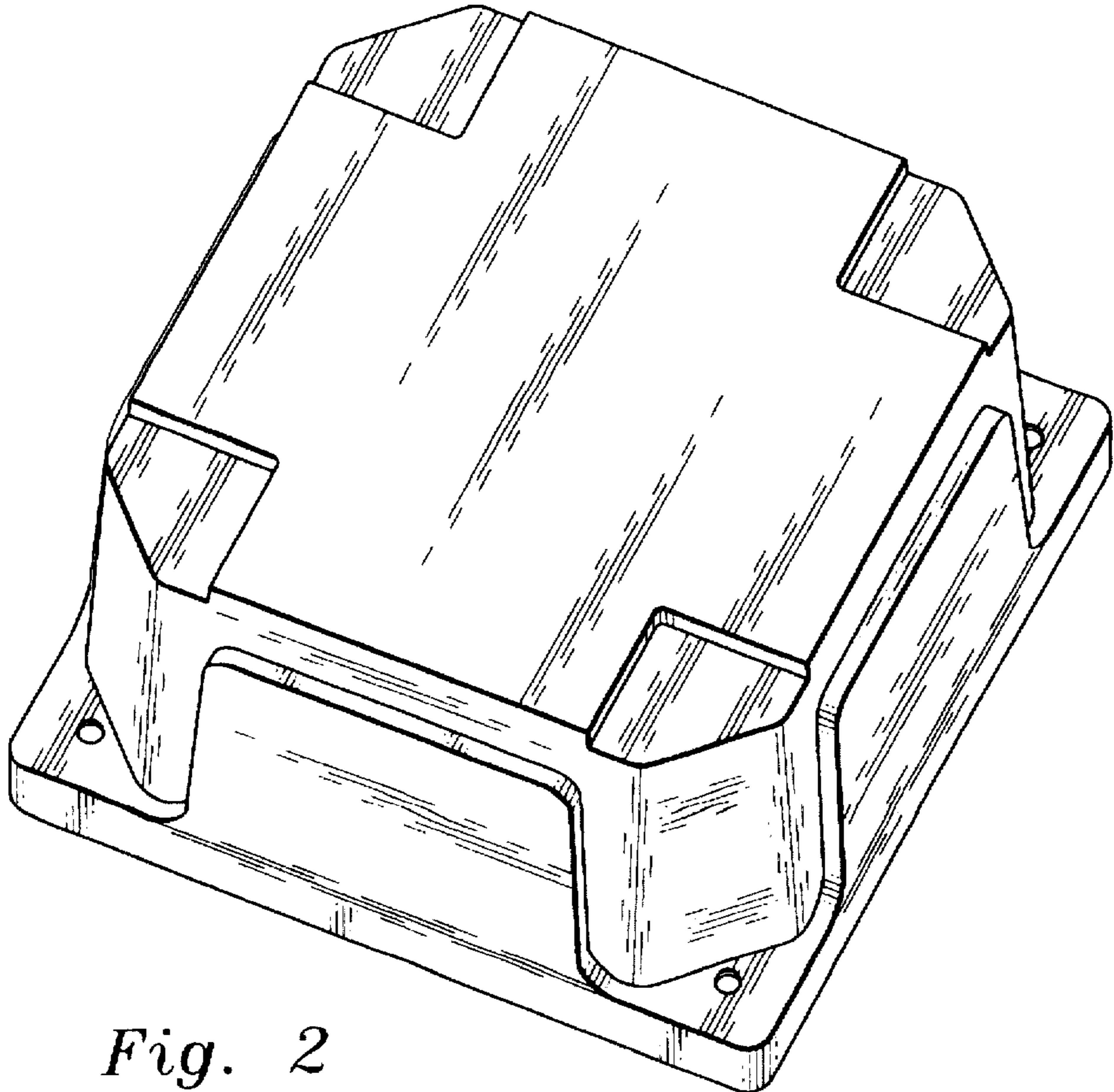

Fig. 2

Fig. 3

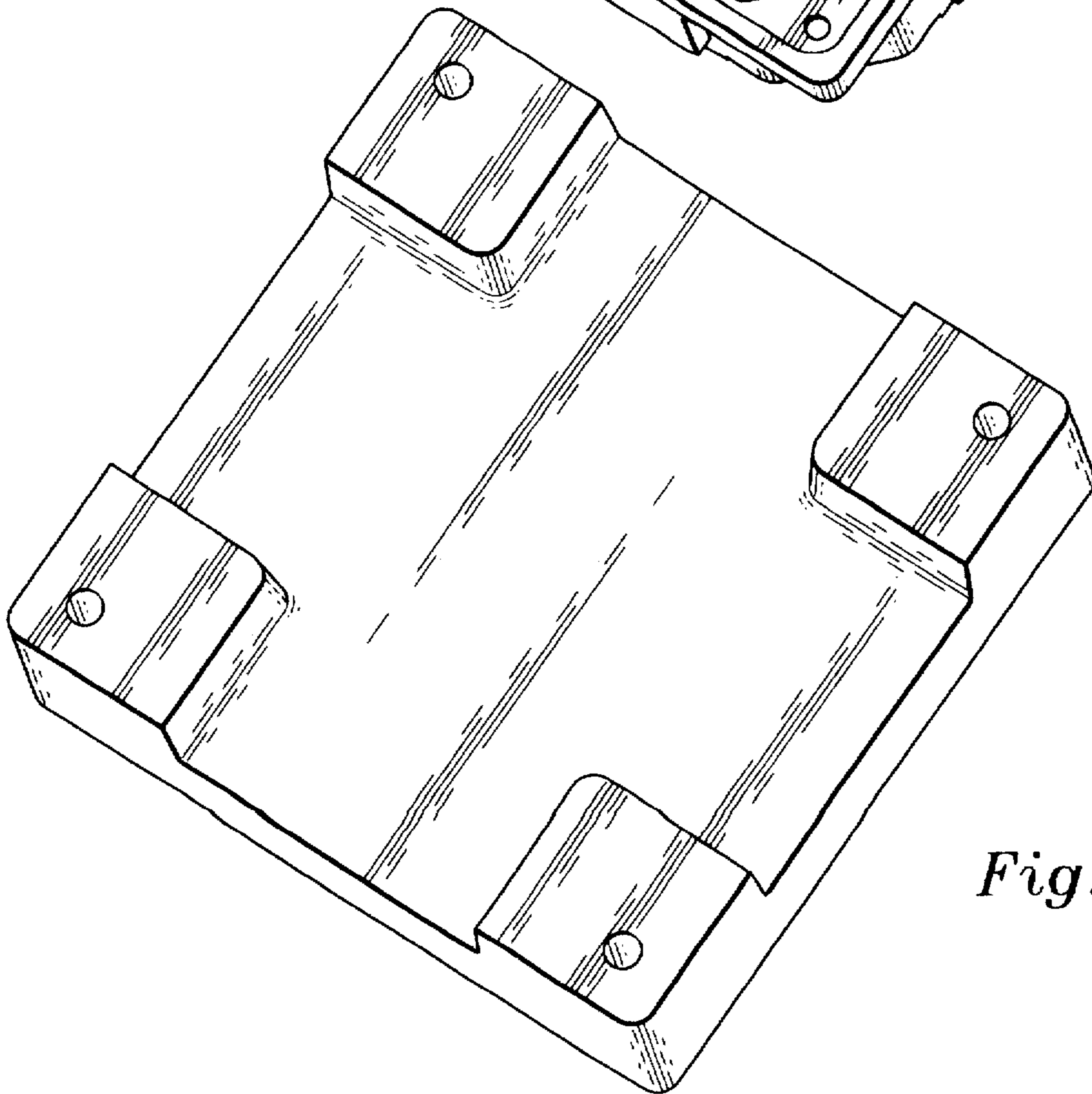
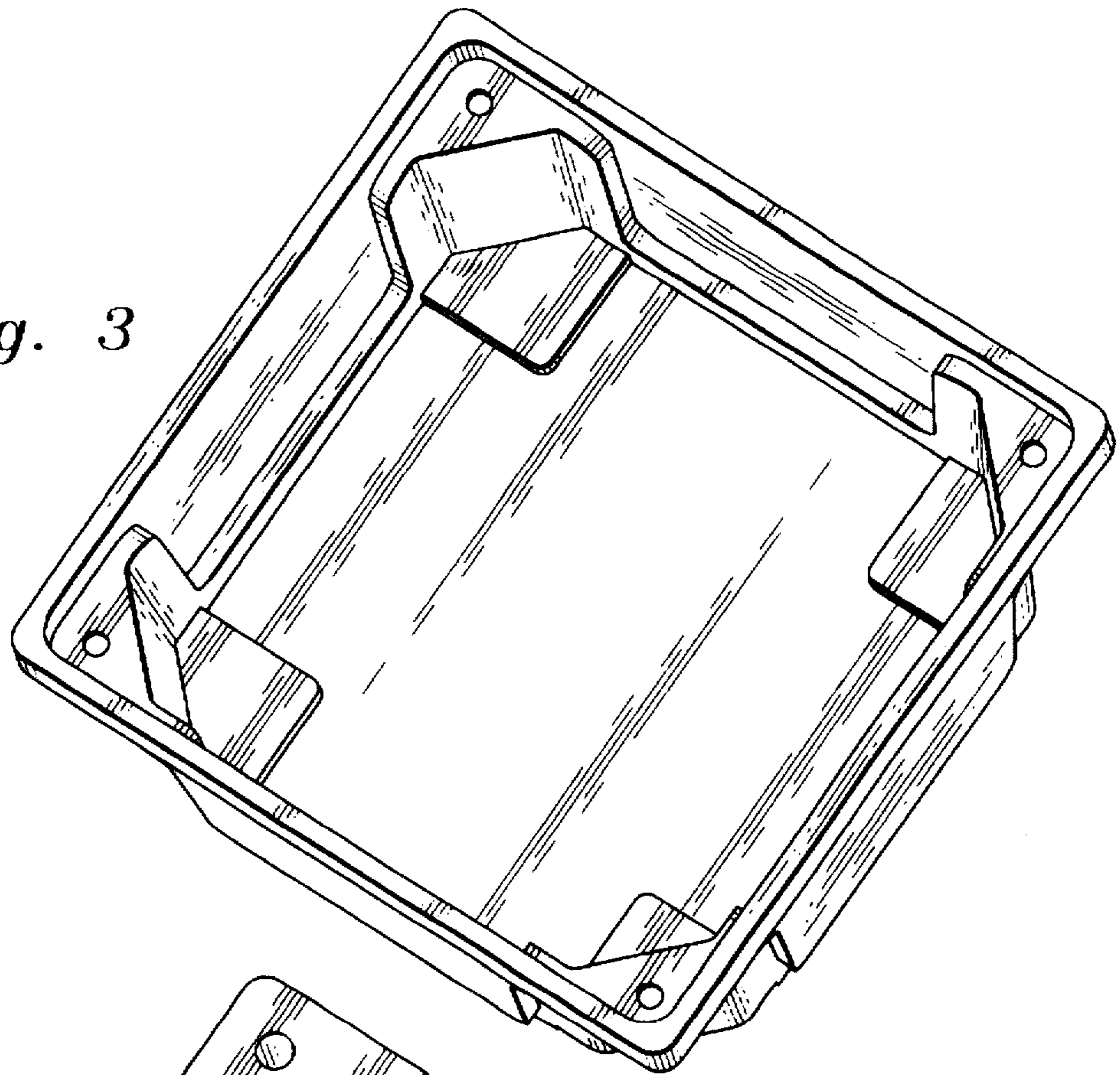

Fig. 4

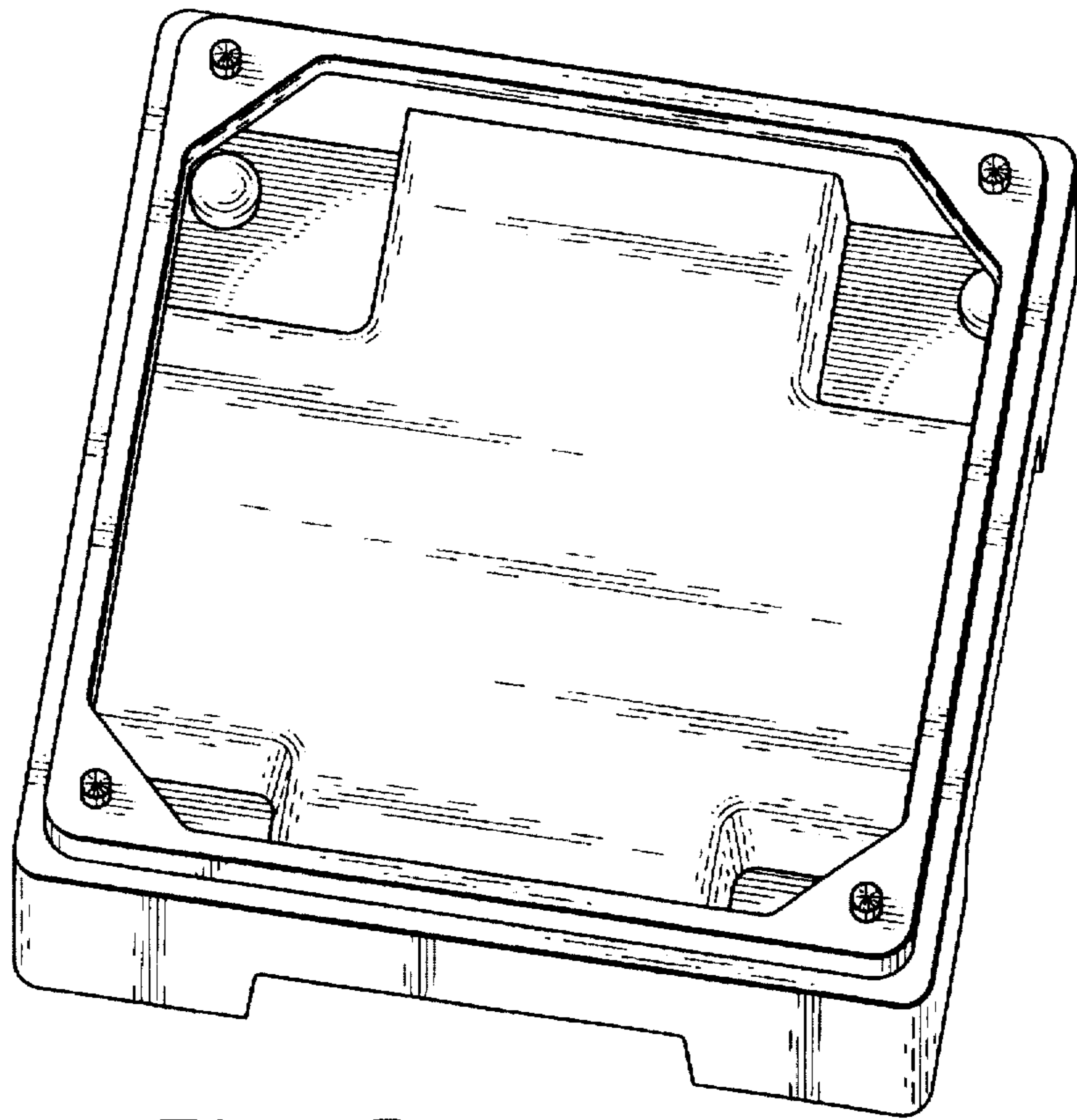

Fig. 5

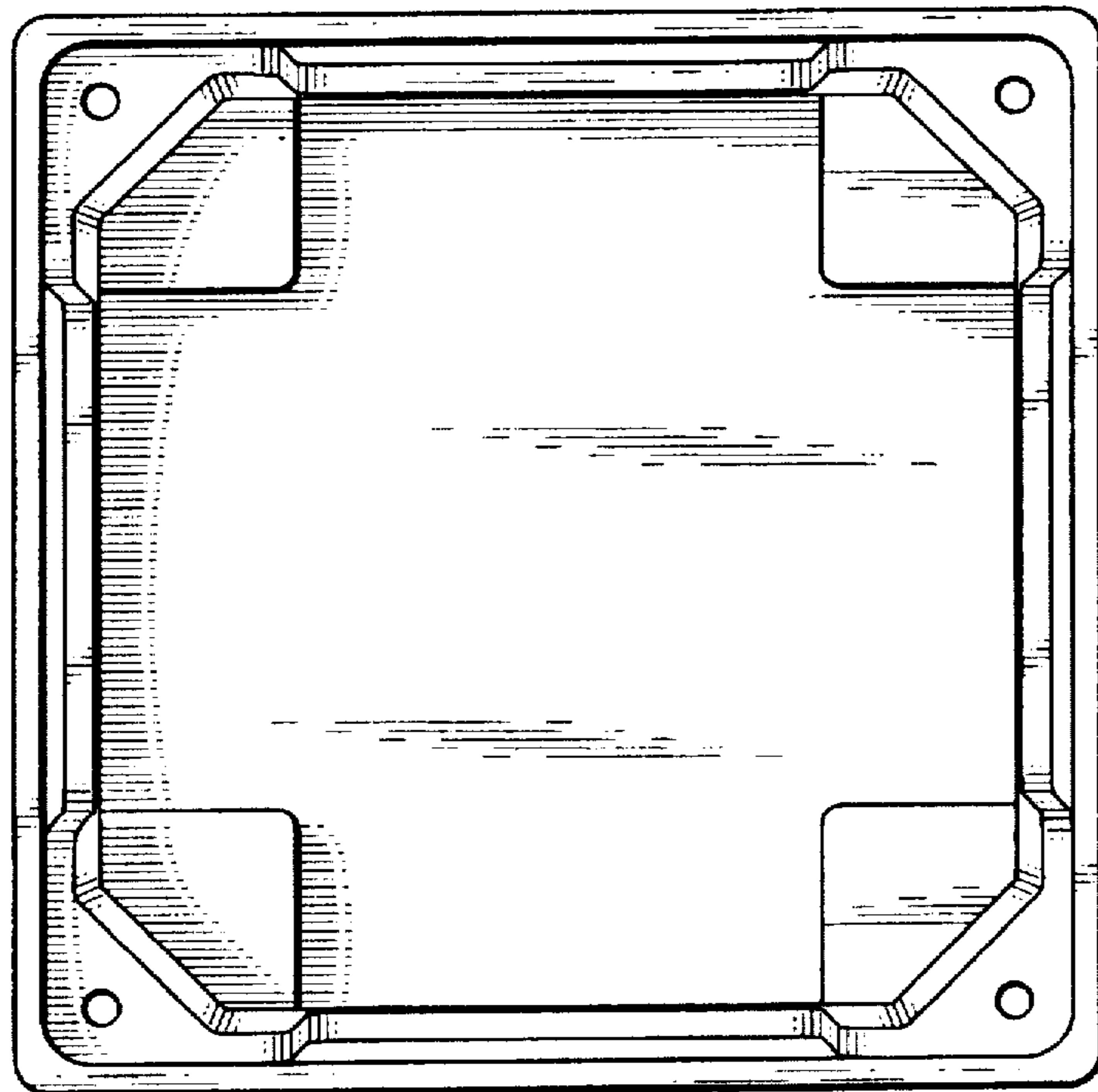

Fig. 6