



US00D391086S

# United States Patent [19]

Catchings et al.

[11] Patent Number: **Des. 391,086**

[45] Date of Patent: **\*\*Feb. 24, 1998**

[54] **VEHICLE SEAT**

5,029,928	7/1991	Huber	.....	297/452.41 X
5,501,501	3/1996	White et al.	.....	296/64
5,516,179	5/1996	Tidwell	.....	296/63

[76] Inventors: **Roosevelt Catchings; Sylvia Catchings**, both of 4329 Becon Pl., Jackson, Miss. 39213

*Primary Examiner*—Gary D. Watson  
*Attorney, Agent, or Firm*—Harpman & Harpman

[\*\*] Term: **14 Years**

[57] **CLAIM**

[21] Appl. No.: **62,017**

The ornamental design for a vehicle seat, as shown and described.

[22] Filed: **Nov. 5, 1996**

### DESCRIPTION

[51] LOC (6) Cl. .... **06-01**

[52] U.S. Cl. .... **D6/356; D6/362; D6/368**

[58] **Field of Search** ..... D6/334, 335, 336, D6/356, 362, 368, 500, 501, 502; 296/37.15, 63, 64; 297/14, 250.1, 254, 255, 452.41

FIG. 1 is a front, top and side perspective view of the vehicle seat embodying the design of the present invention; FIG. 2 is a left side elevational view thereof; FIG. 3 is a right side elevational view thereof; FIG. 4 is a front elevational view thereof; FIG. 5 is a rear elevational view thereof; FIG. 6 is a top plan view thereof; FIG. 7 is a bottom plan view thereof; and, FIG. 8 is a reduced perspective view of the design within a vehicle where the vehicle and placement of an additional seat have been shown in broken lines for environmental purposes only and form no part of the claimed design.

### [56] References Cited

#### U.S. PATENT DOCUMENTS

D. 227,833	7/1973	Olson	.....	D6/368
D. 271,731	12/1983	Chamberlain et al.	.....	D6/362
D. 297,287	8/1988	Lopez	.....	D6/356
D. 326,568	6/1992	Lanius et al.	.....	D6/356
2,792,875	5/1957	Pirrone	.....	D6/368 X
4,580,832	4/1986	Maruyama et al.	.....	297/14

**1 Claim, 5 Drawing Sheets**

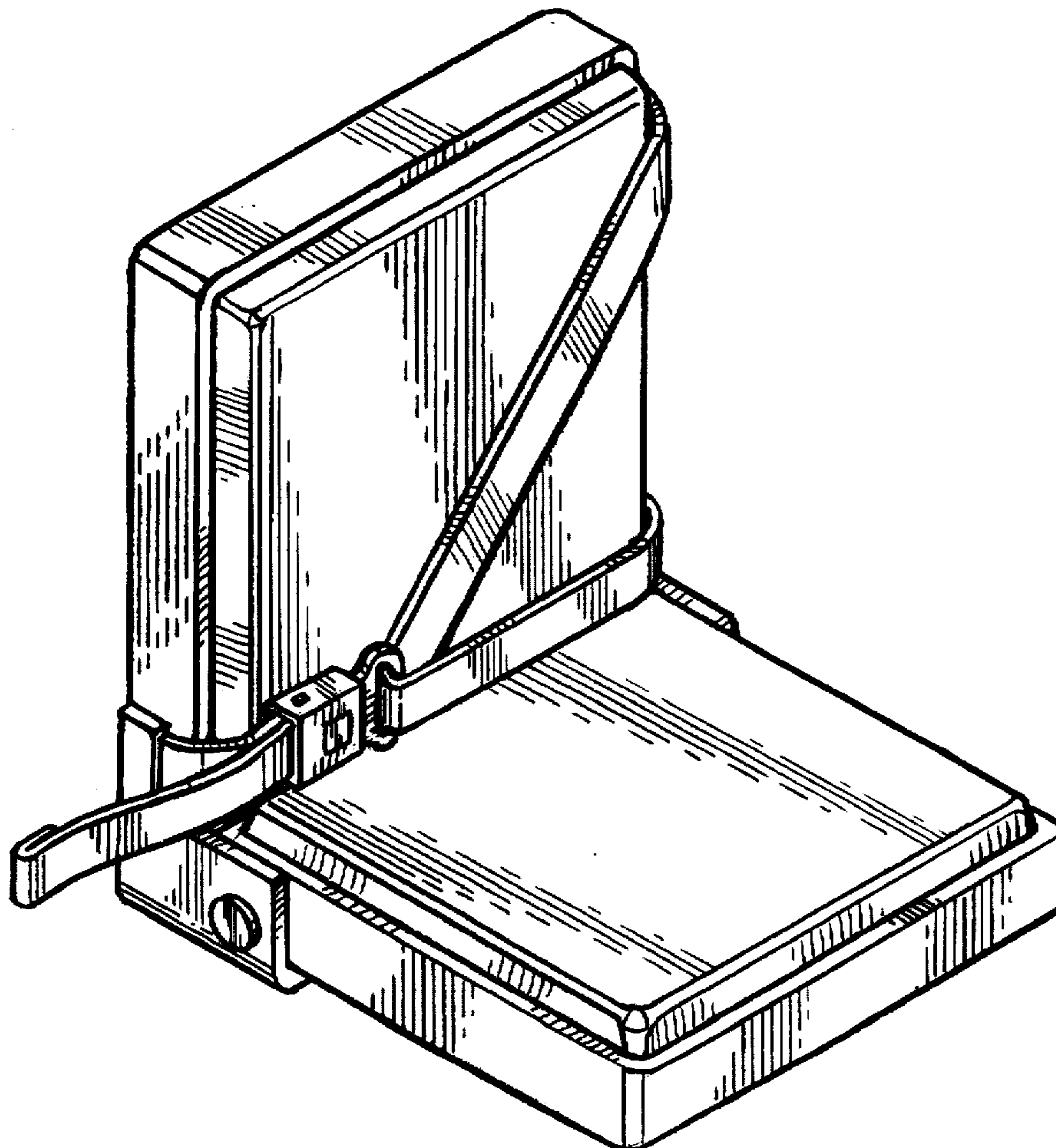

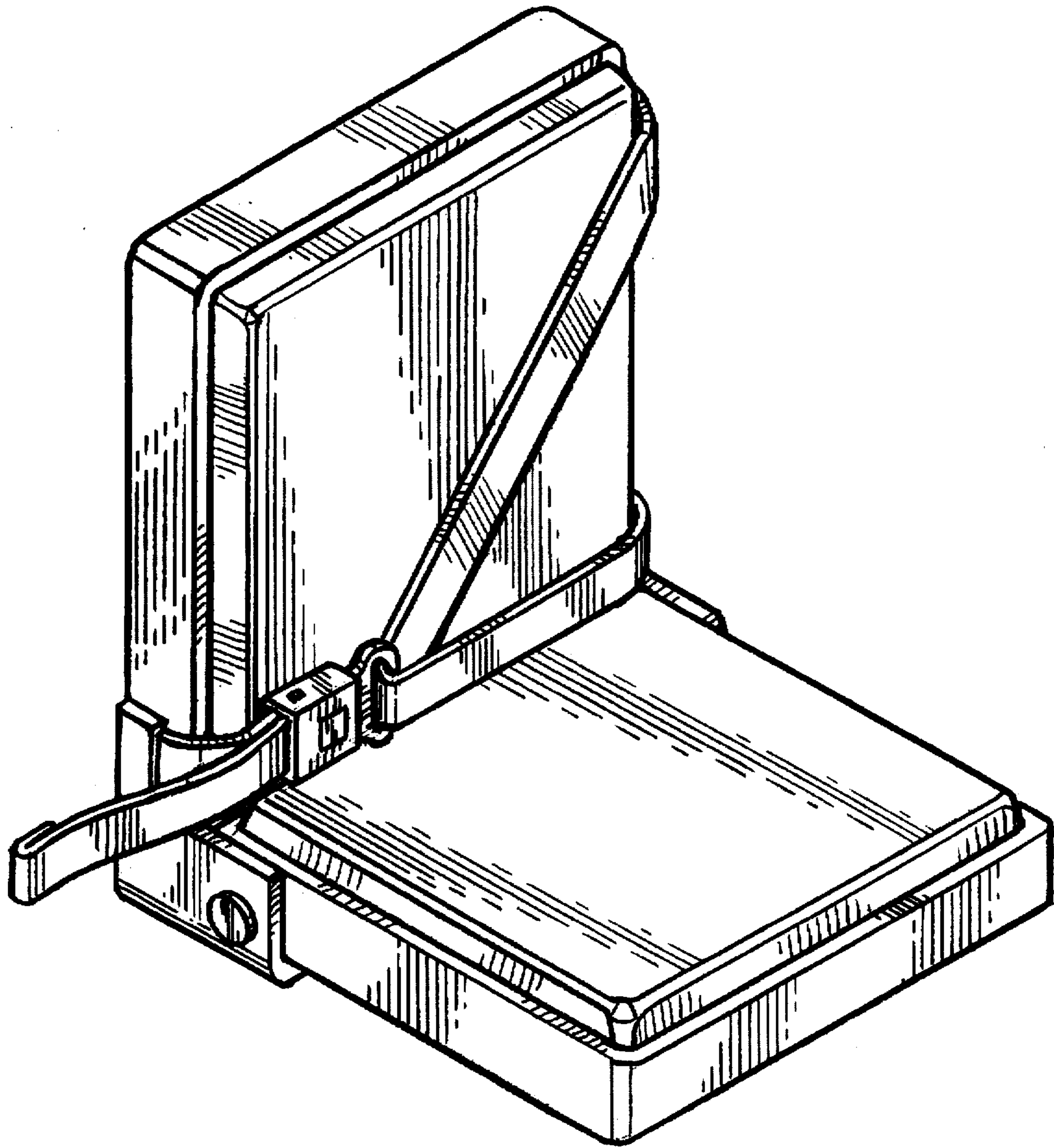

FIG. 1

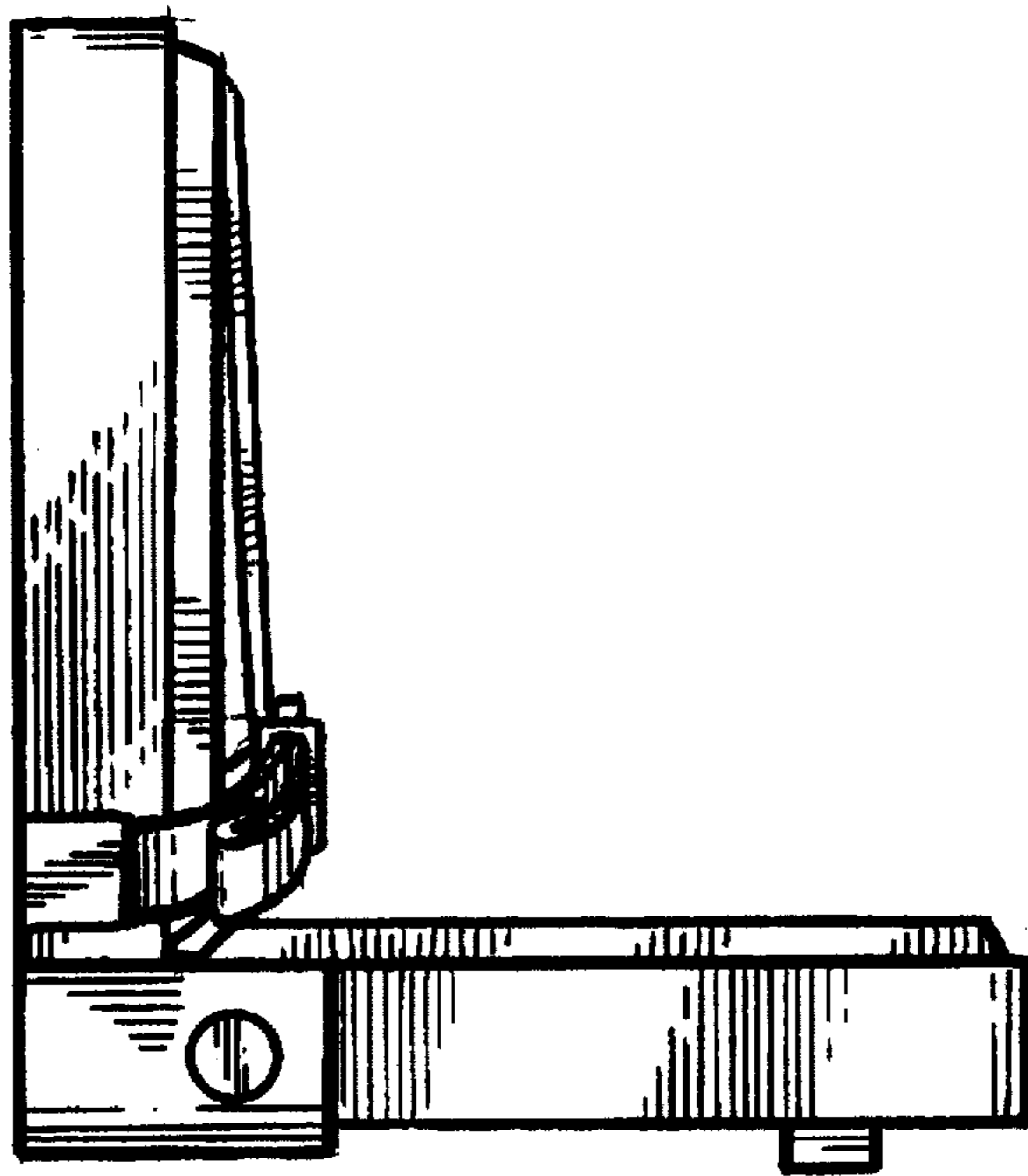

FIG. 2

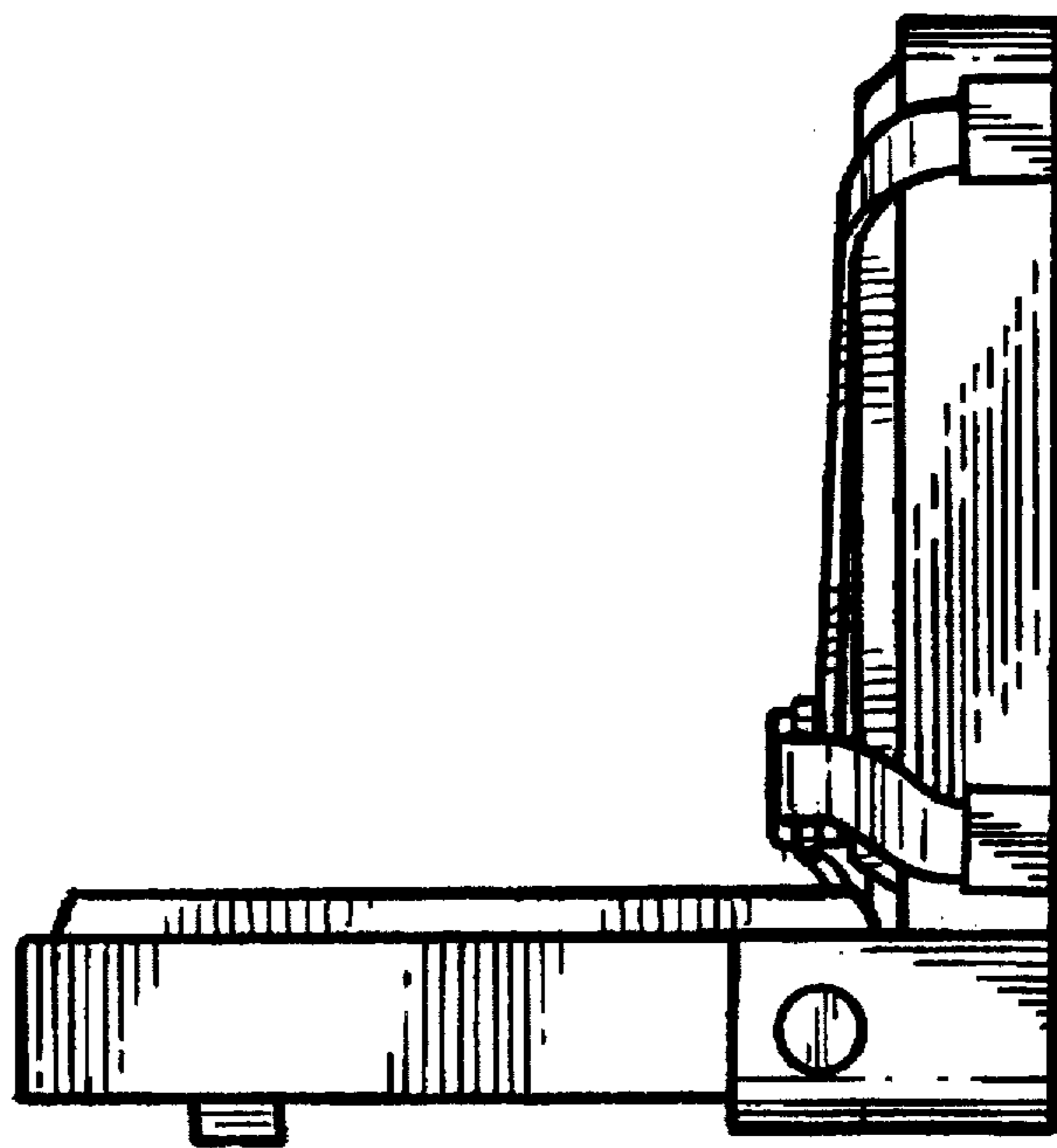

FIG. 3

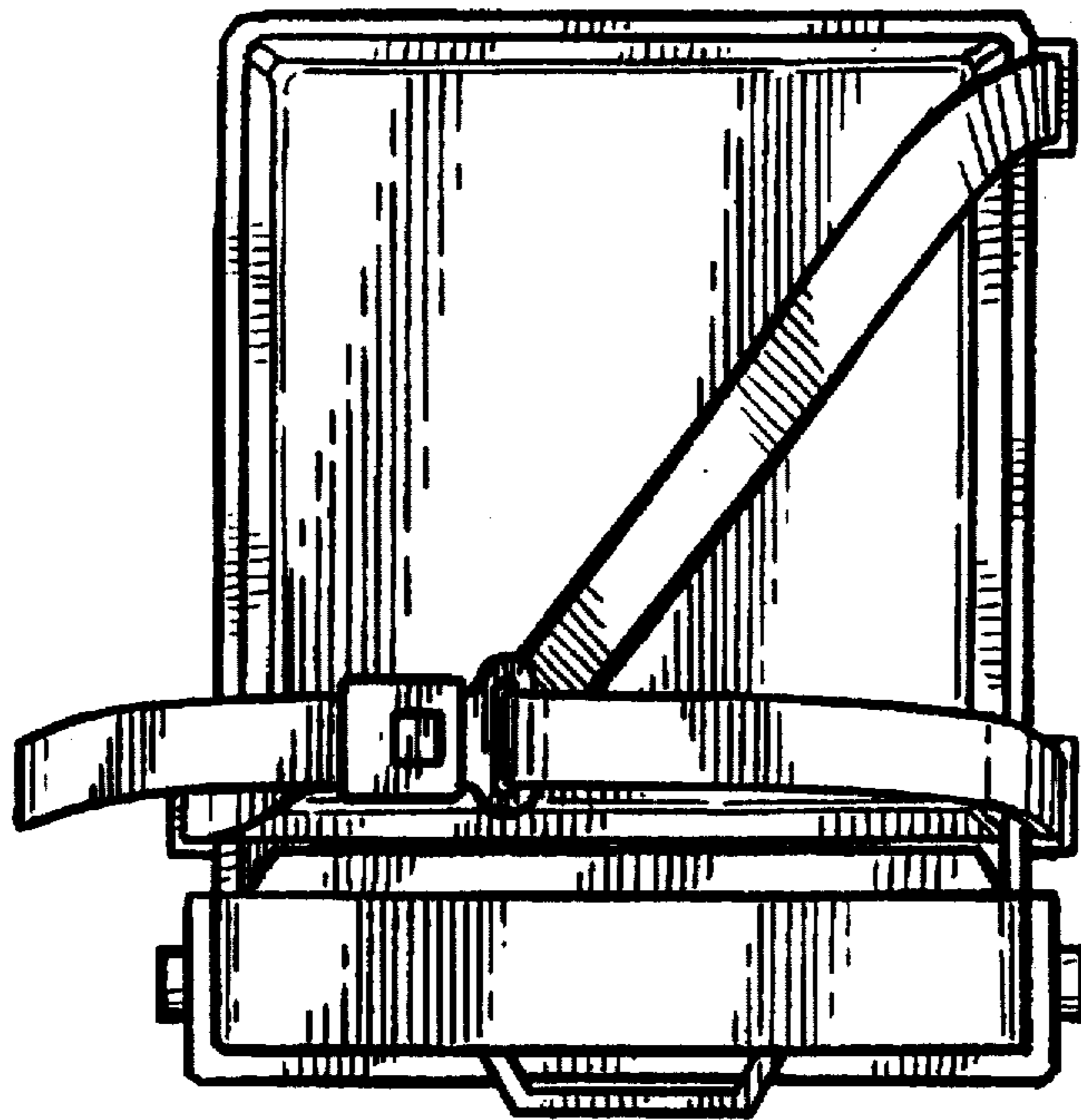

FIG. 4

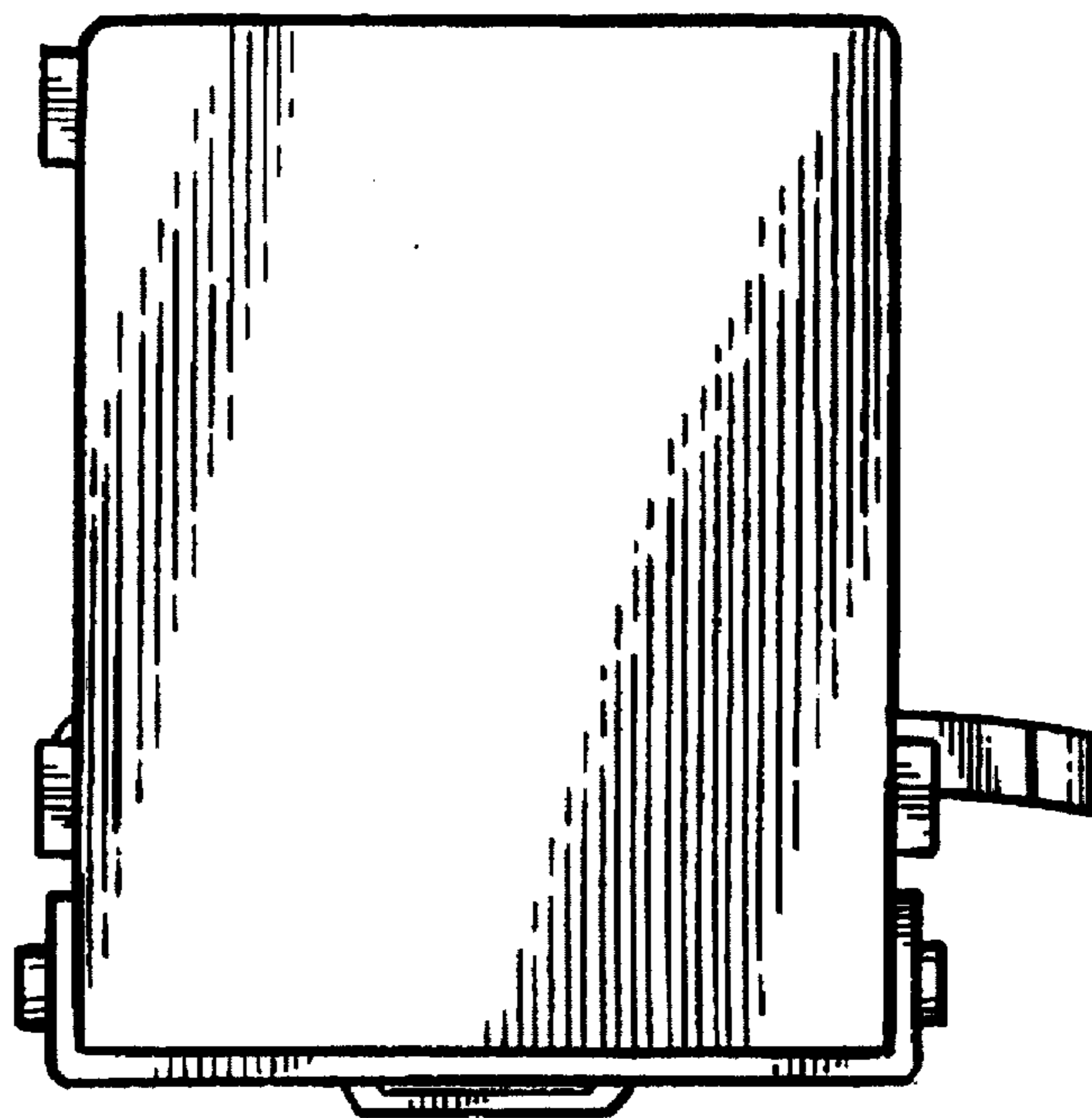

FIG. 5

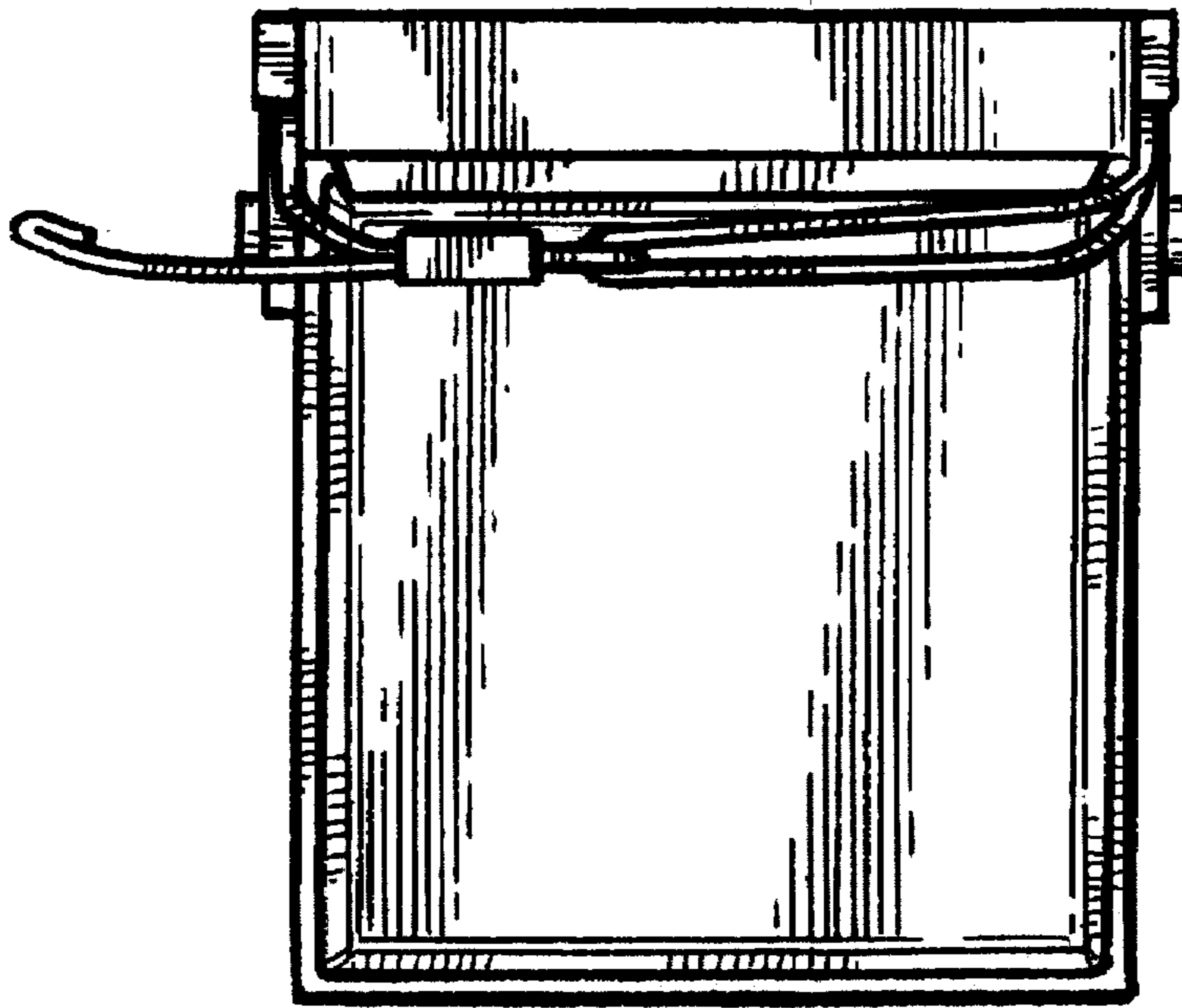

FIG. 6

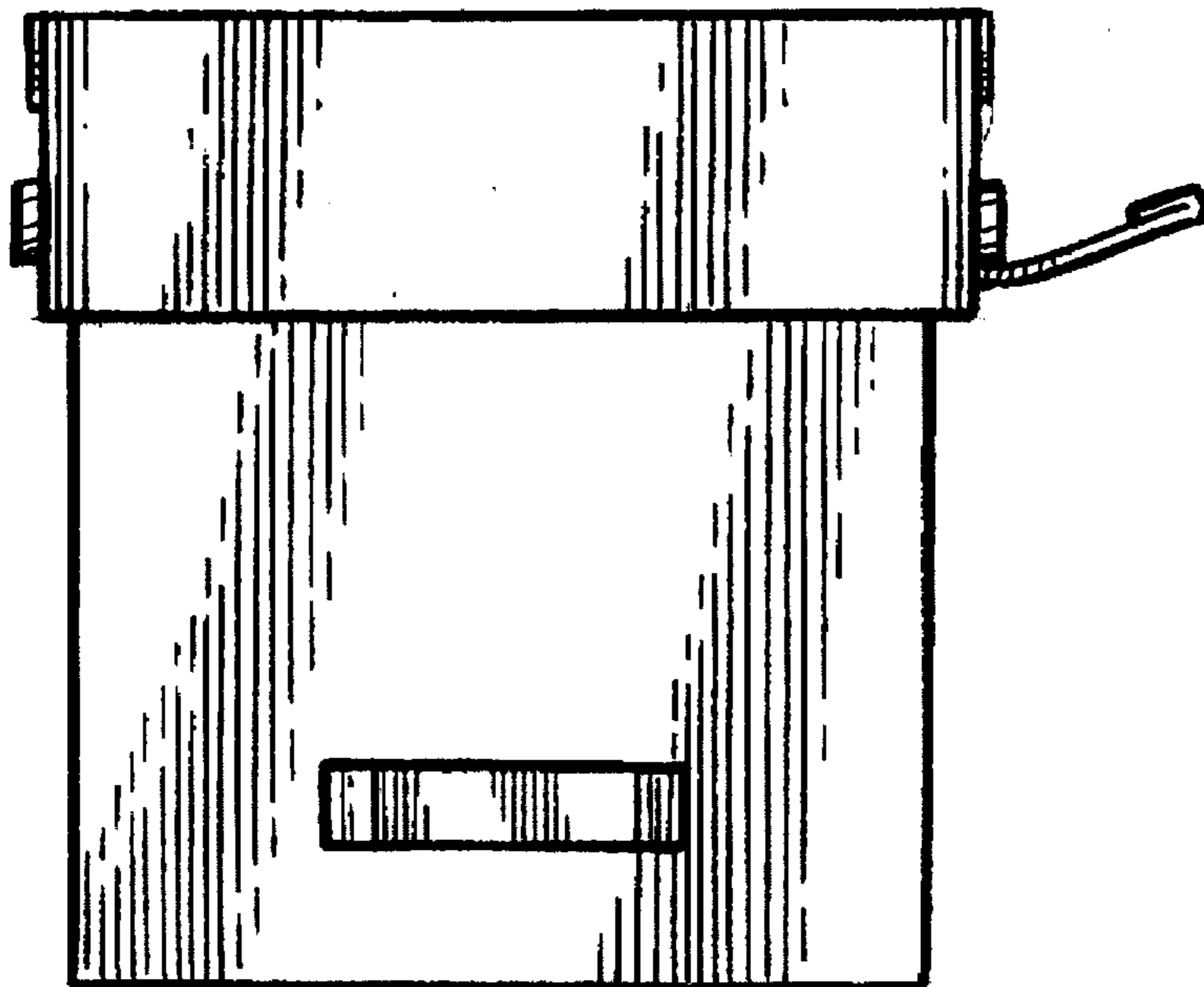

FIG. 7

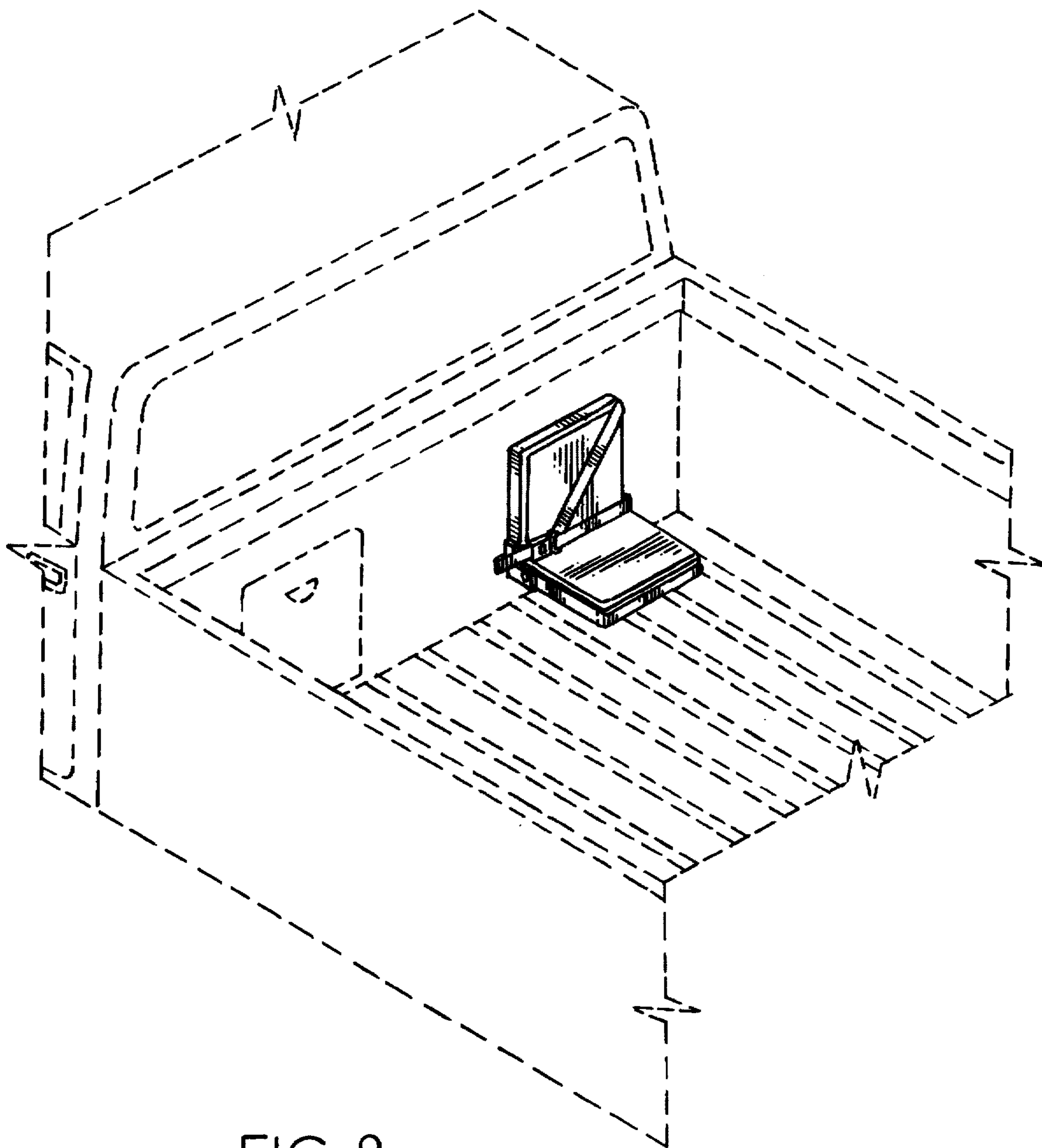

FIG. 8.