



US00D390795S

United States Patent [19]
LaFrance

[11] **Patent Number: Des. 390,795**
[45] **Date of Patent: **Feb. 17, 1998**

[54] **MARKER/SCRIBE FOR TAPE MEASURE**

[76] **Inventor: Jeff LaFrance**, P.O. Box 1316,
Lakeport, Calif. 95453

[**] **Term: 14 Years**

[21] **Appl. No.: 68,676**

[22] **Filed: Mar. 19, 1997**

[51] **LOC (6) Cl. 10-04**

[52] **U.S. Cl. D10/74**

[58] **Field of Search D10/74; 33/768,**
33/769, 770

[56] **References Cited**

U.S. PATENT DOCUMENTS

5,477,619 12/1995 Kearns 33/668
5,577,329 11/1996 States 33/368 X

Primary Examiner—Antoine Duval Davis

Attorney, Agent, or Firm—Larry D. Johnson

[57] **CLAIM**

The ornamental design for a marker/scribe for tape measure, as shown and described.

DESCRIPTION

FIG. 1 is a perspective view of the marker/scribe for tape measure showing my new design installed on a tape measure shown in phantom lines;

FIG. 2 is a front elevational view installed on a tape measure shown in phantom lines;

FIG. 3 is a right side elevational view on a tape measure shown in phantom lines;

FIG. 4 is a rear elevational view thereof;

FIG. 5 is a left side elevational view thereof;

FIG. 6 is a top plan view on a tape measure shown in phantom lines; and,

FIG. 7 is a bottom plan view thereof.

1 Claim, 2 Drawing Sheets

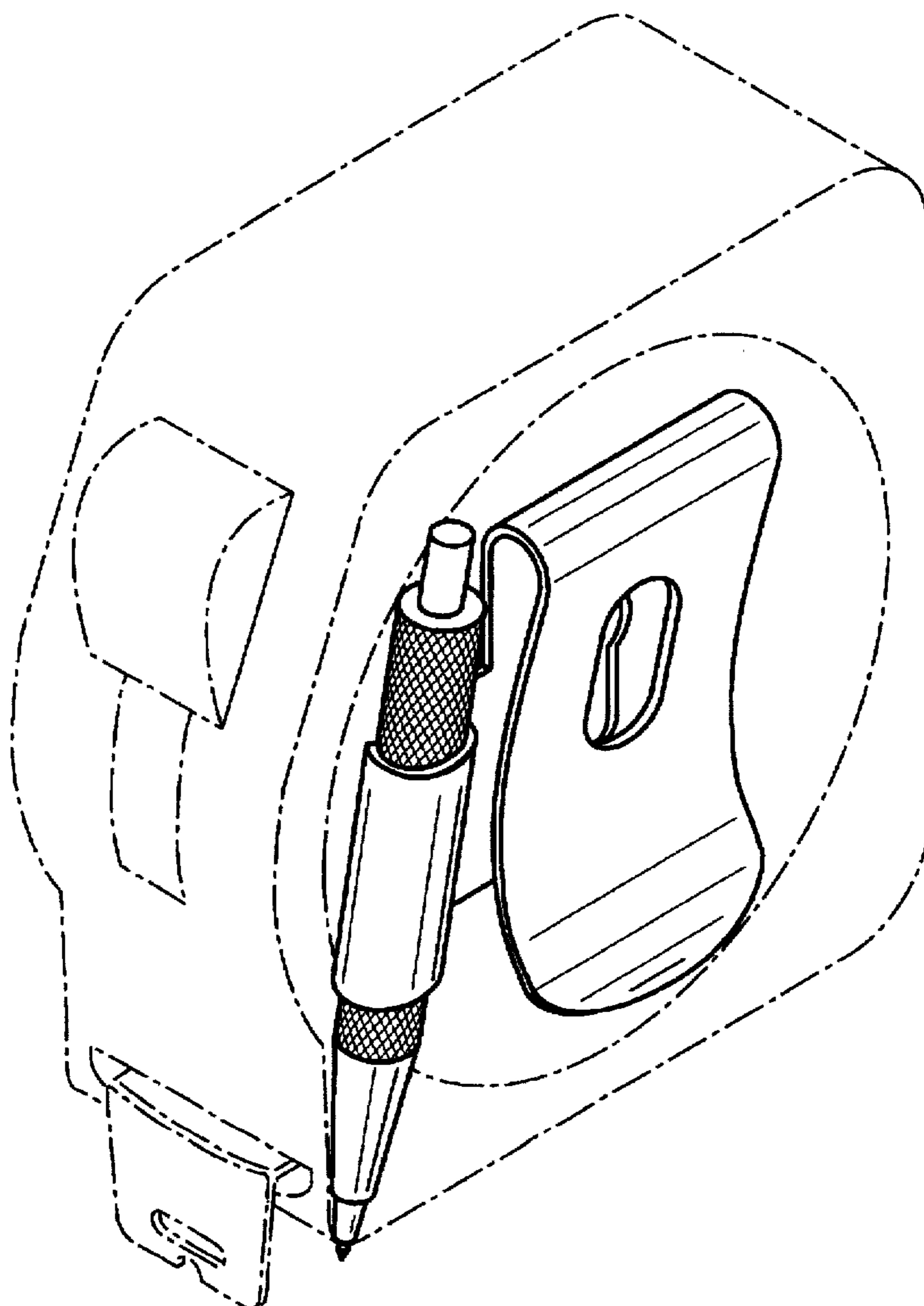

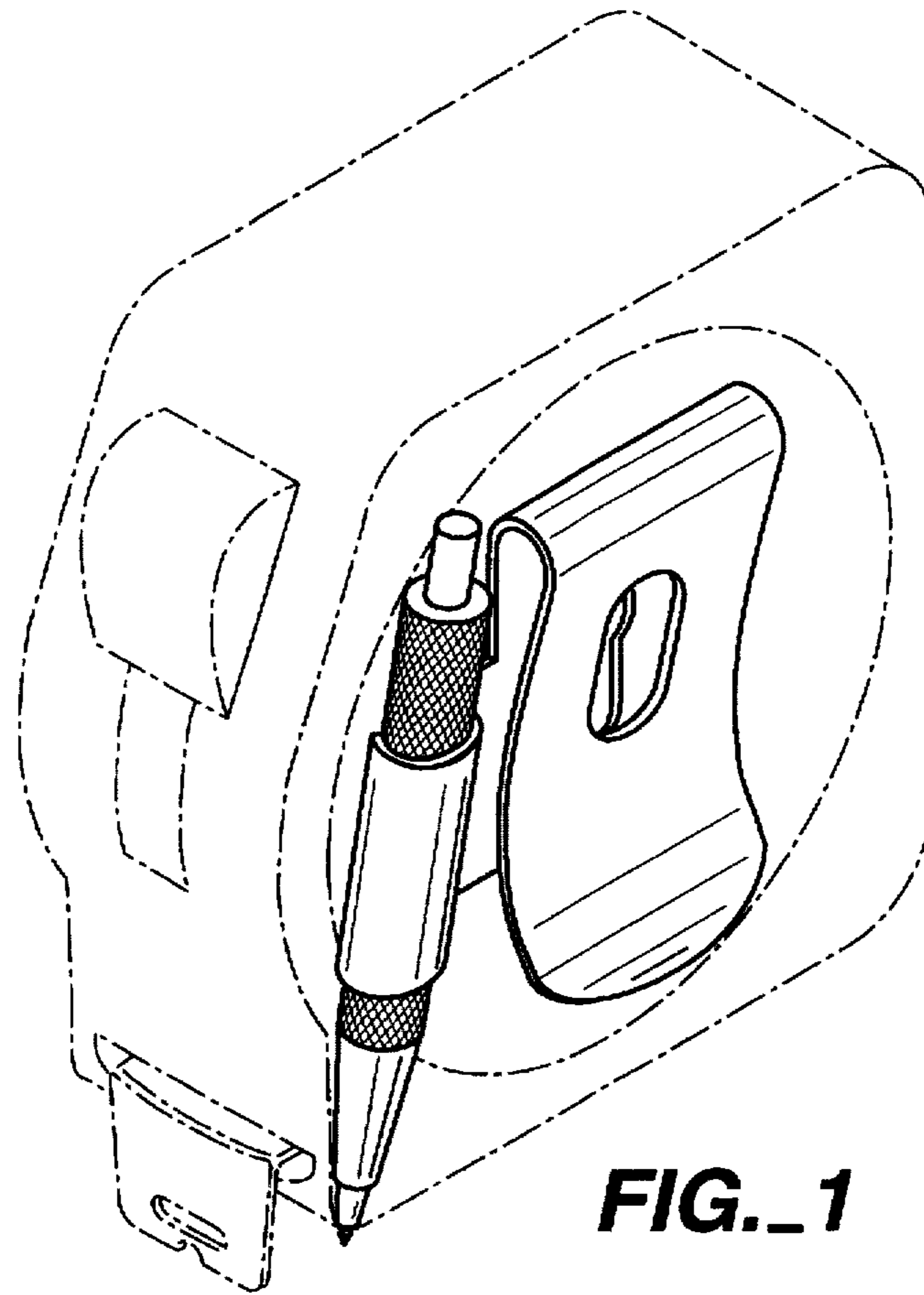

FIG._1

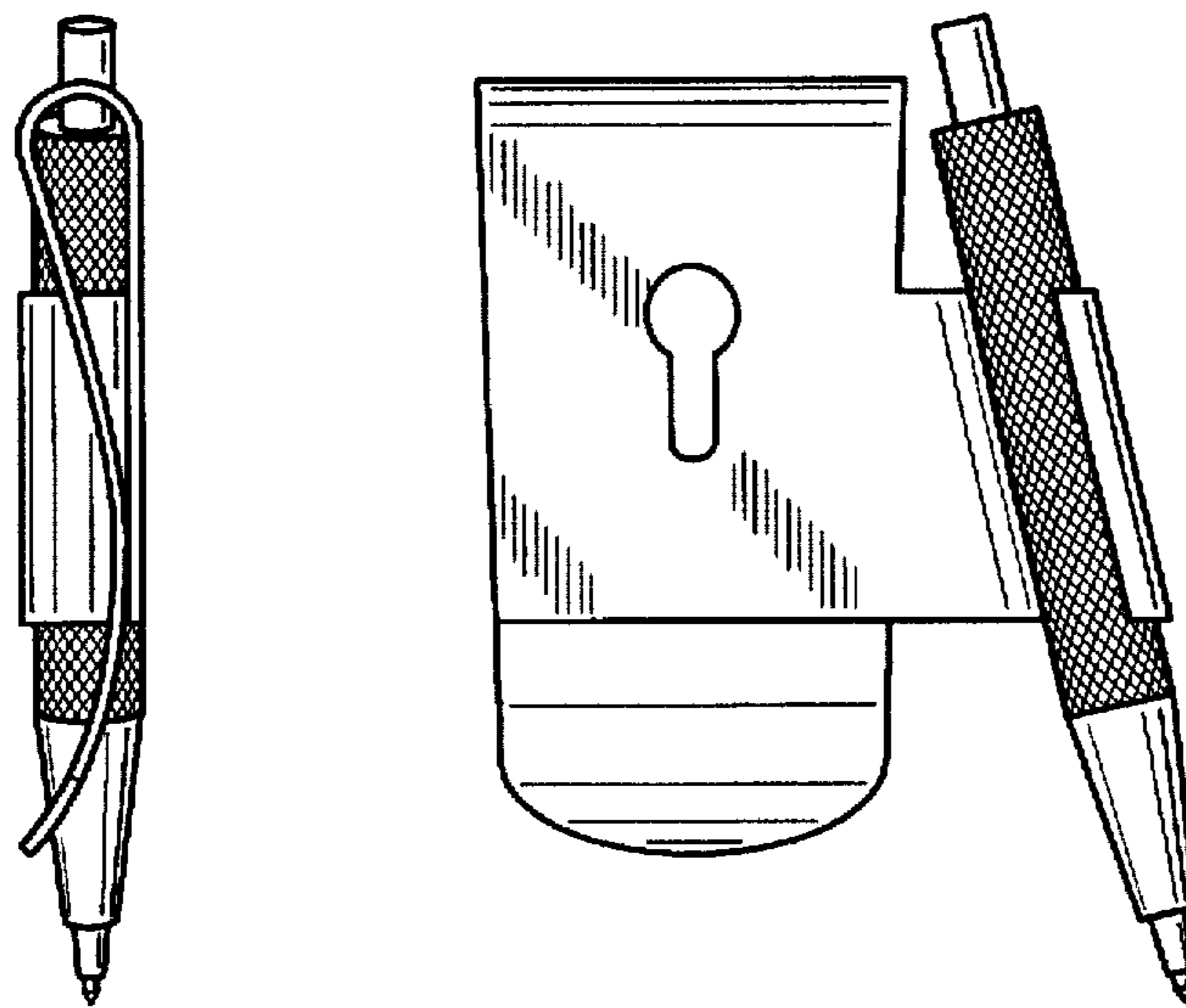

FIG._4

FIG._5

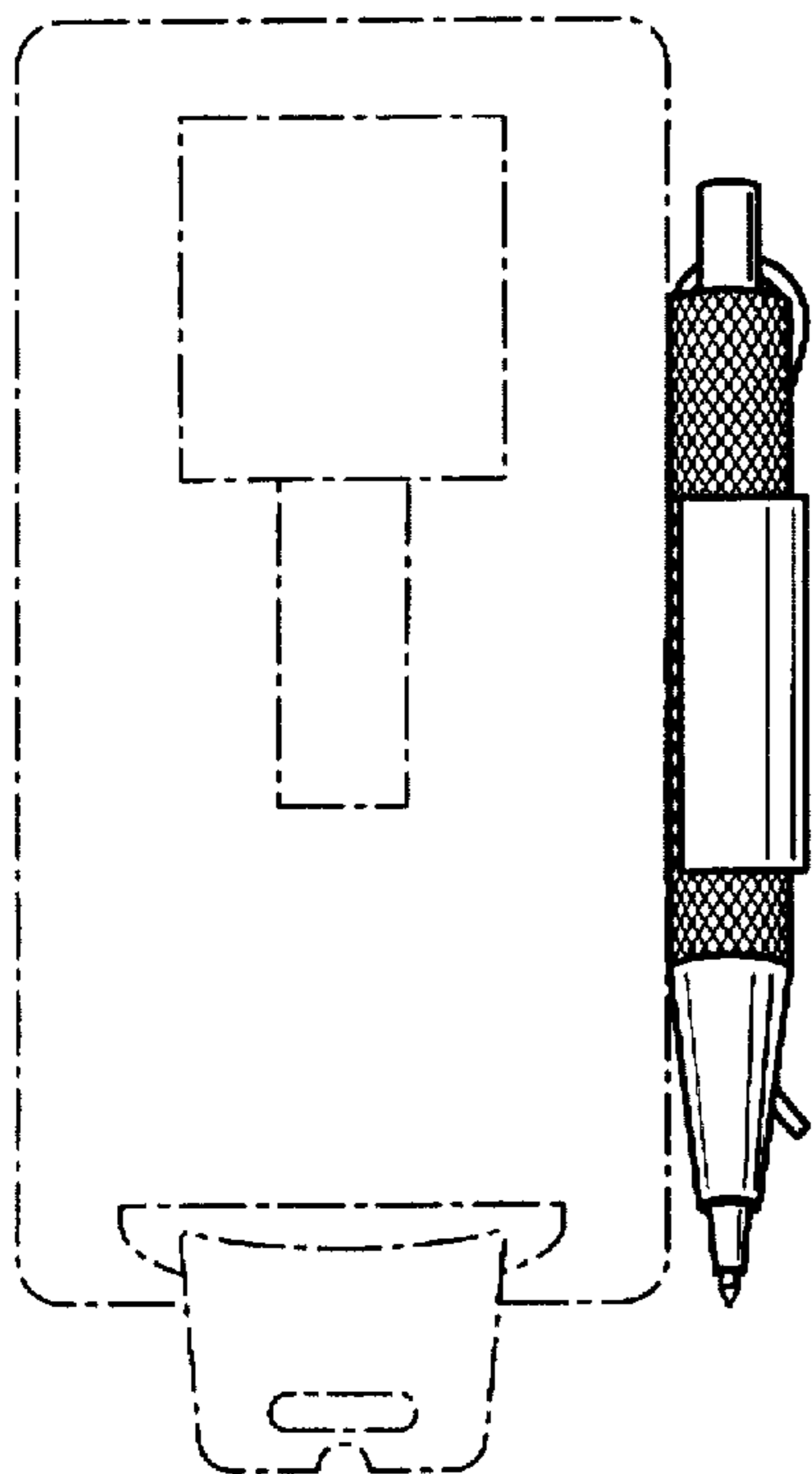

FIG._2

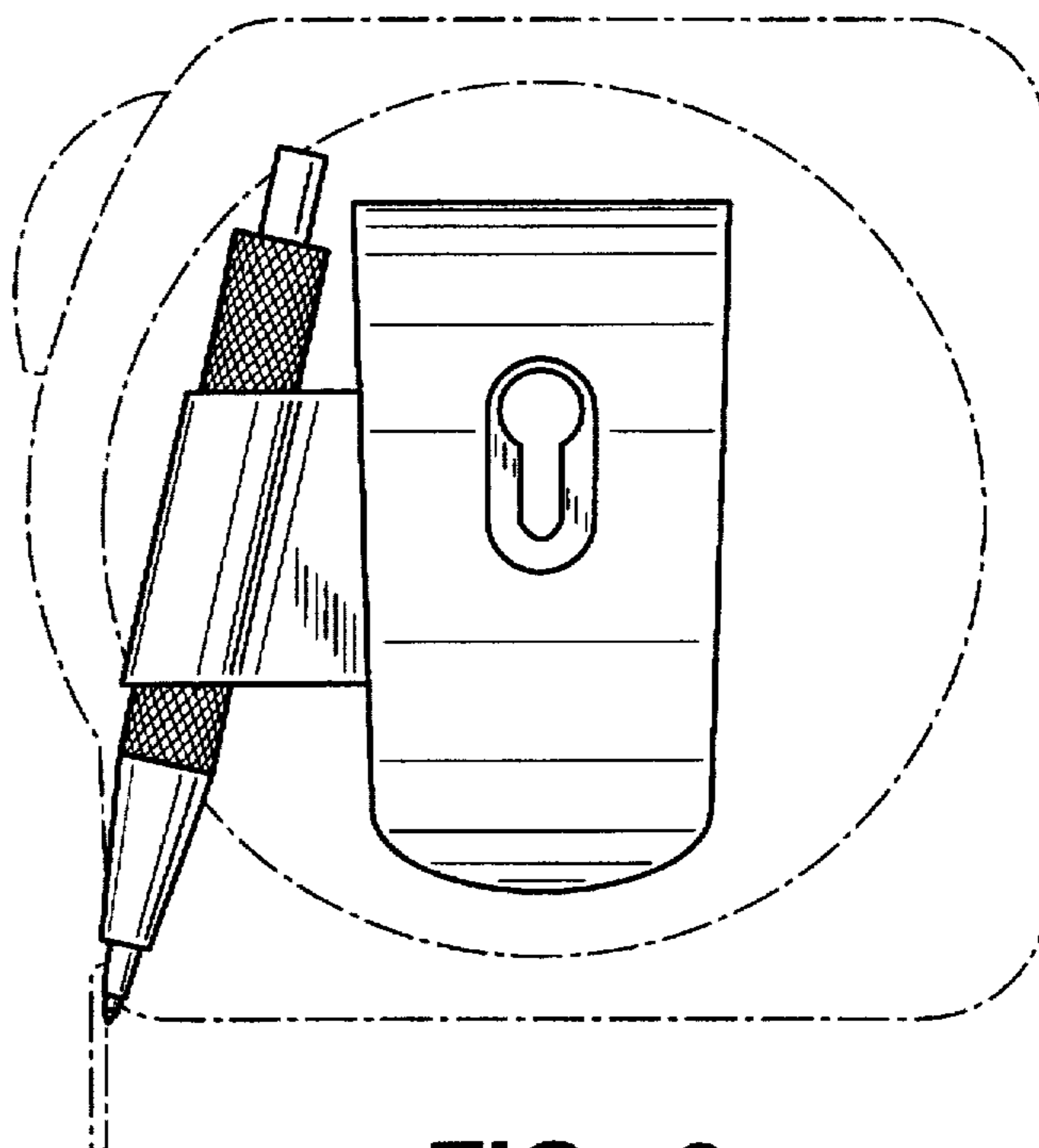

FIG._3

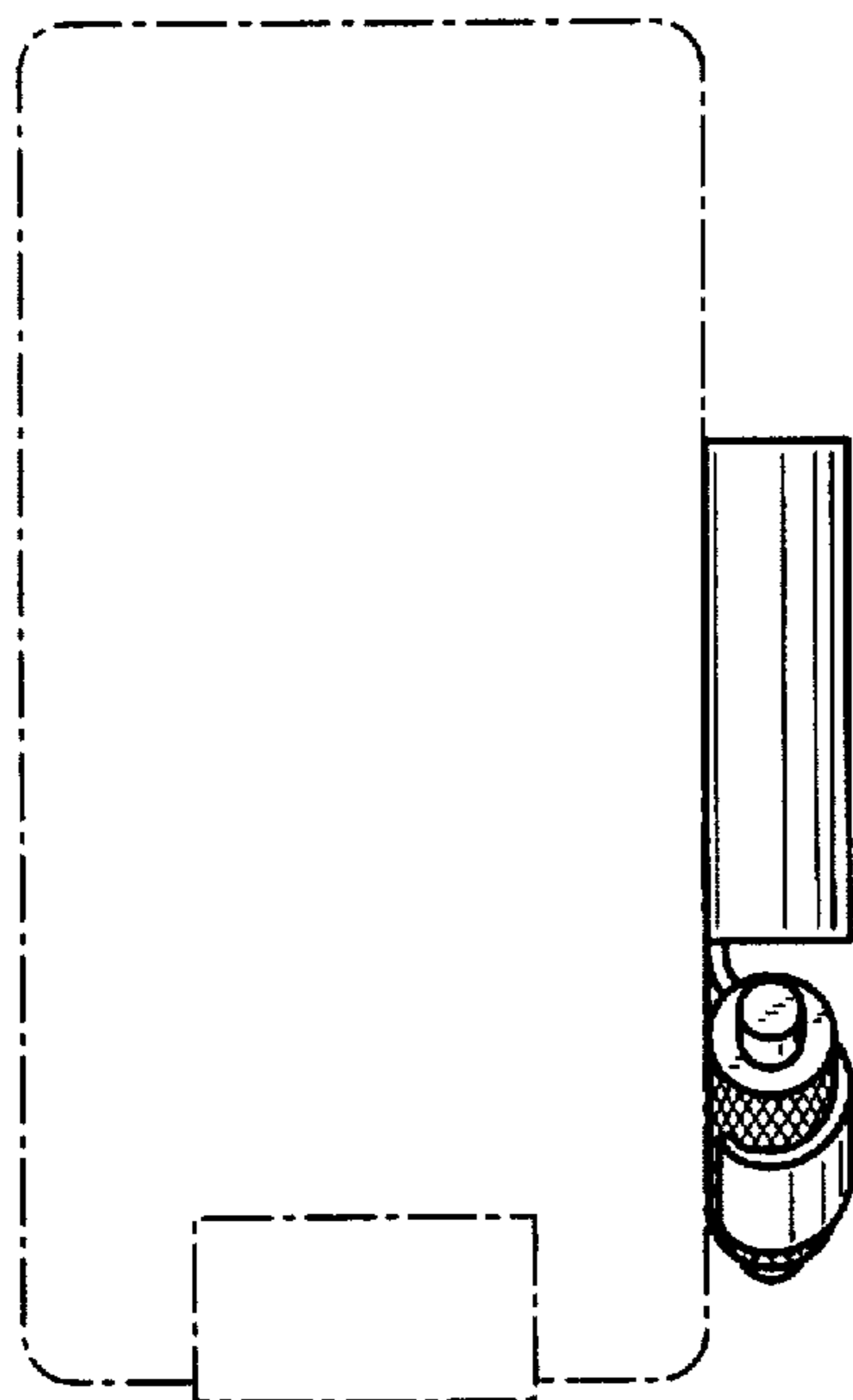

FIG._6



FIG._7