



US00D390534S

# United States Patent [19] Prucey

[11] Patent Number: **Des. 390,534**  
[45] Date of Patent: **\*\*Feb. 10, 1998**

[54] **ELECTRICAL CONNECTOR HOUSING**

[75] Inventor: **Philip P. Prucey**, Perry, Ohio

[73] Assignee: **Namco Controls Corporation**,  
Highland Heights, Ohio

[\*\*] Term: **14 Years**

[21] Appl. No.: **67,952**

[22] Filed: **Mar. 5, 1997**

### Related U.S. Application Data

[63] Continuation of Ser. No. 43,001, Aug. 22, 1995, abandoned.

[51] LOC (6) Cl. .... **13-03**

[52] U.S. Cl. .... **D13/146**

[58] Field of Search ..... D13/133, 146,  
D13/147, 151; 174/59, 65 R; 333/112, 126,  
127; 439/218, 224, 278, 578-585, 608,  
610

### [56] References Cited

#### U.S. PATENT DOCUMENTS

2,538,088	1/1951	Desloge .	
3,139,480	6/1964	Desloge .....	174/65 R
3,500,253	3/1970	Oprysko .....	333/126
3,639,752	2/1972	Appleton .	
3,641,464	2/1972	Crowhurst et al. .	
3,904,812	9/1975	Daffron .....	439/278 X
3,951,490	4/1976	Devendorf .	
4,141,615	2/1979	Takeuchi et al. .	

4,734,541	3/1988	Moran, Jr. .
4,845,312	7/1989	Lee .
4,851,609	7/1989	Reddy .
5,057,971	10/1991	Hautvast et al. .

### OTHER PUBLICATIONS

SDS™ Physical Layer Specification, Honeywell Micro Switch Division, p. 22 (Apr. 1994).  
SDS Design and Implementation Guide, Honeywell Micro Switch Sensing and Control, pp. 22-23, published prior to Aug. 22, 1995.

*Primary Examiner*—Alan P. Douglas  
*Assistant Examiner*—Lavone D. Tabor  
*Attorney, Agent, or Firm*—Watts, Hoffmann, Fisher & Heinke, Co., L.P.A.

### [57] CLAIM

The ornamental design for an electrical connector housing, as shown and described.

### DESCRIPTION

FIG. 1 is a perspective view of an electrical connector housing showing my new design; FIG. 2 is a front elevational view thereof; FIG. 3 is a rear elevational view thereof; FIG. 4 is a side elevational view thereof; FIG. 5 is a top plan view thereof; and, FIG. 6 is a bottom plan view thereof. The side that is not shown in the drawing is a mirror image of the side that is shown in FIG. 4.

1 Claim, 2 Drawing Sheets

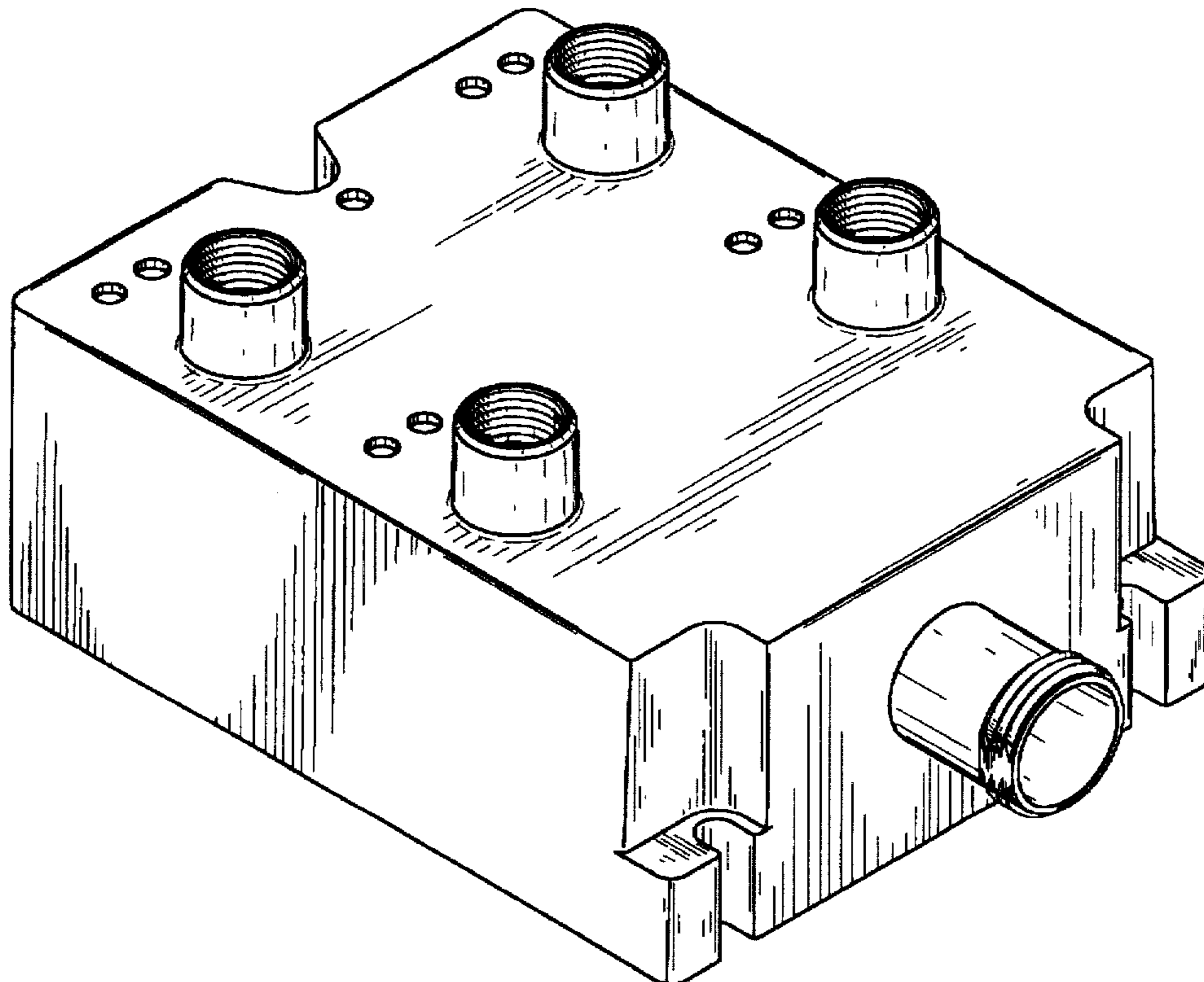

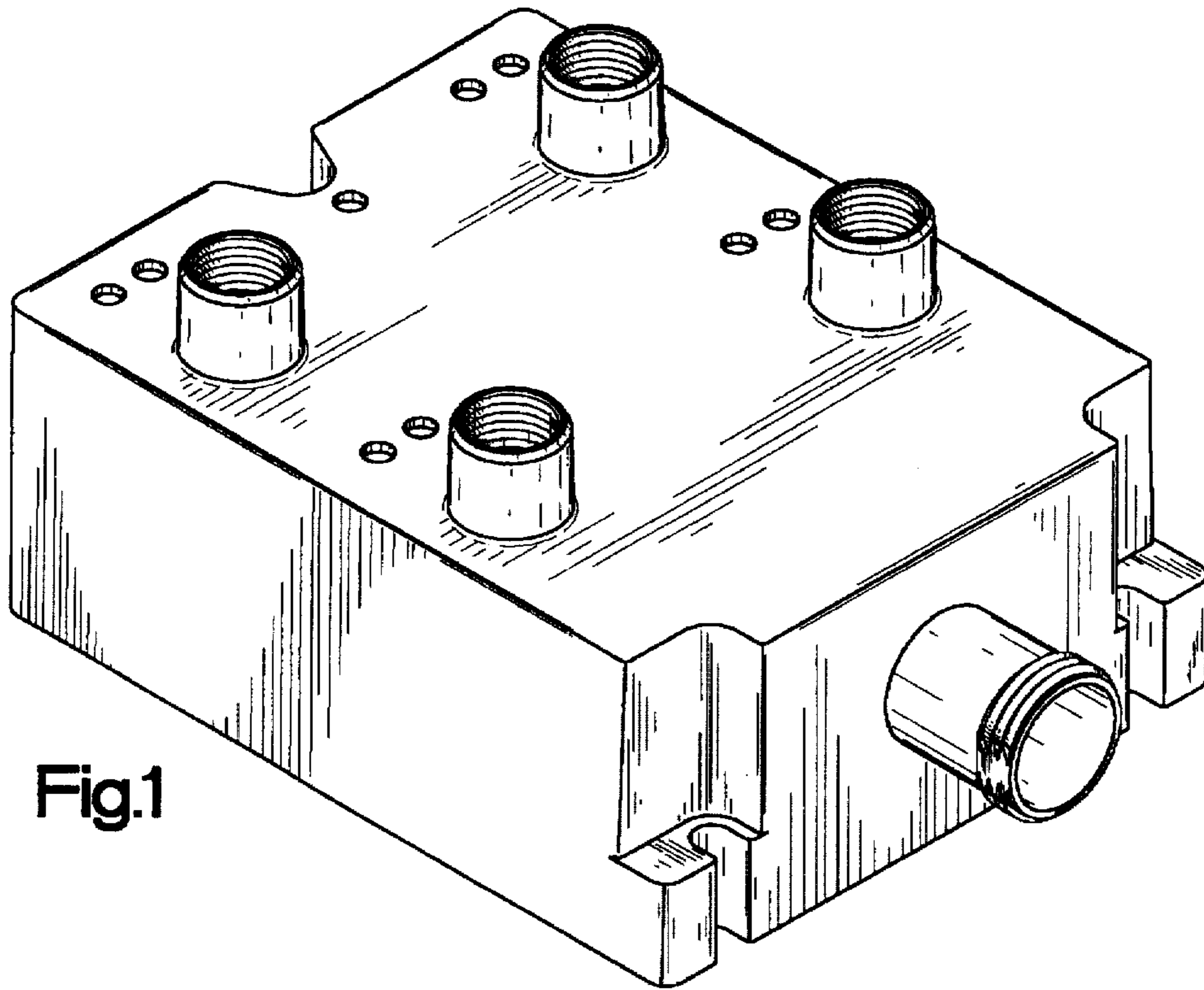

Fig.1

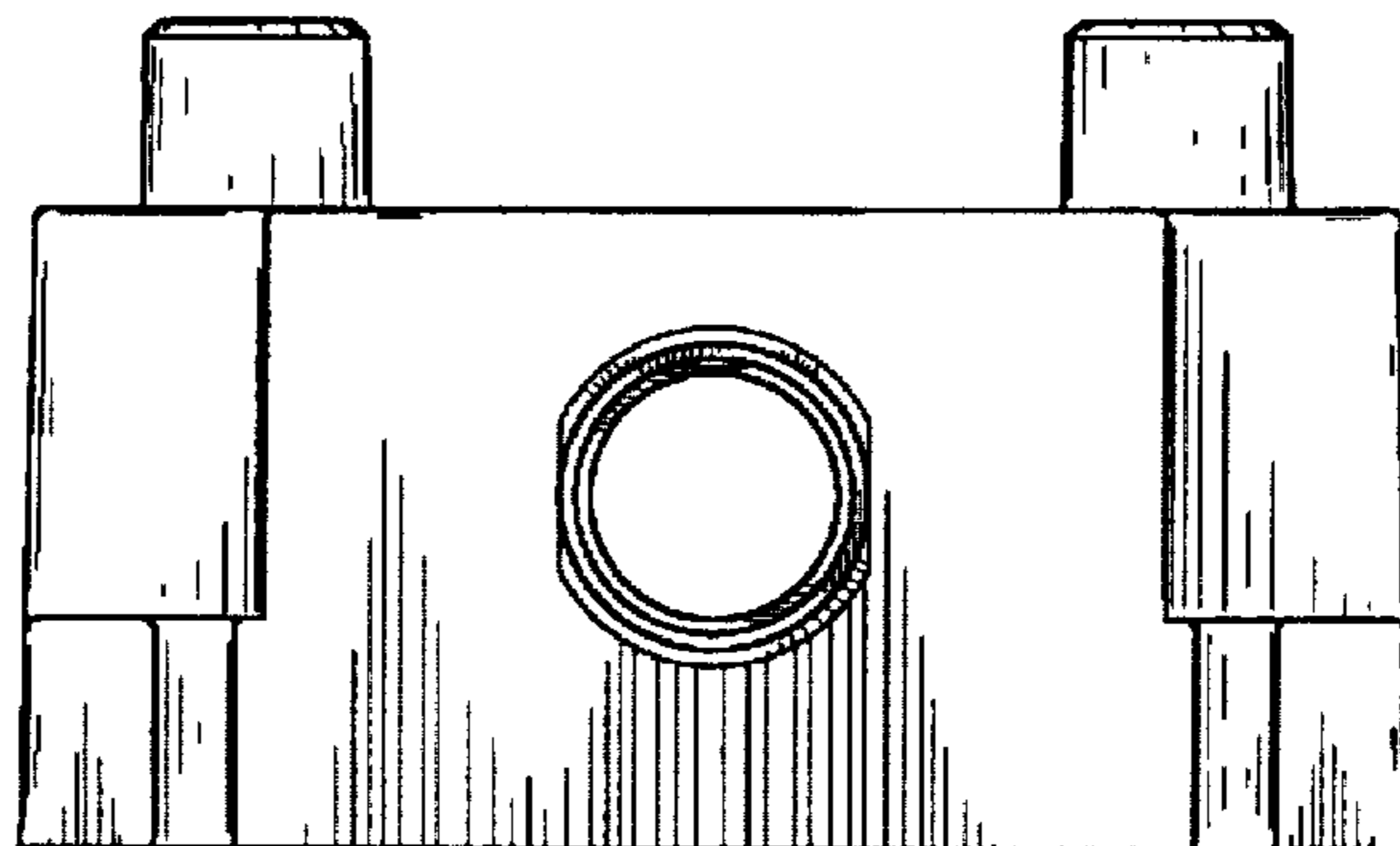

Fig.2

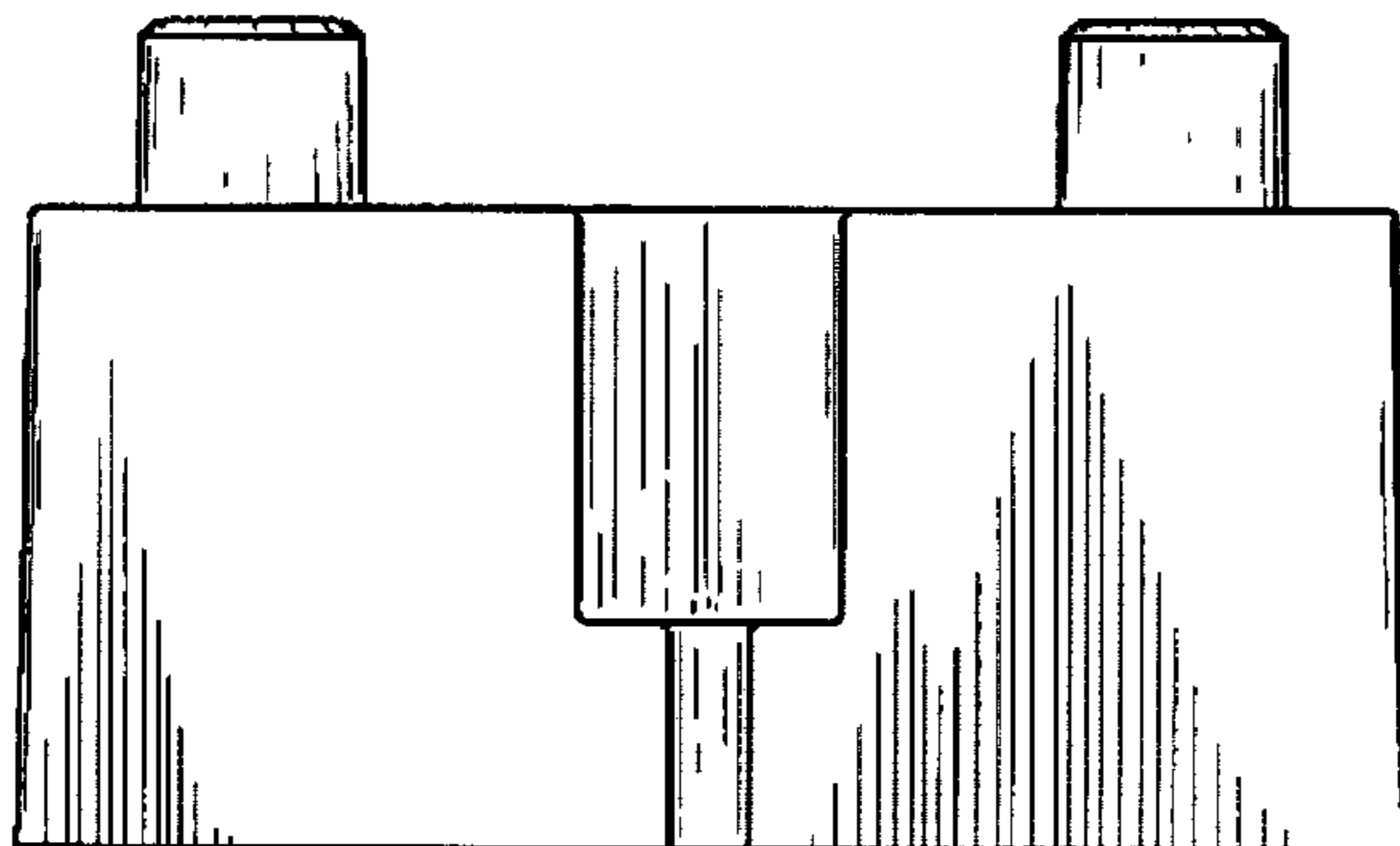

Fig.3

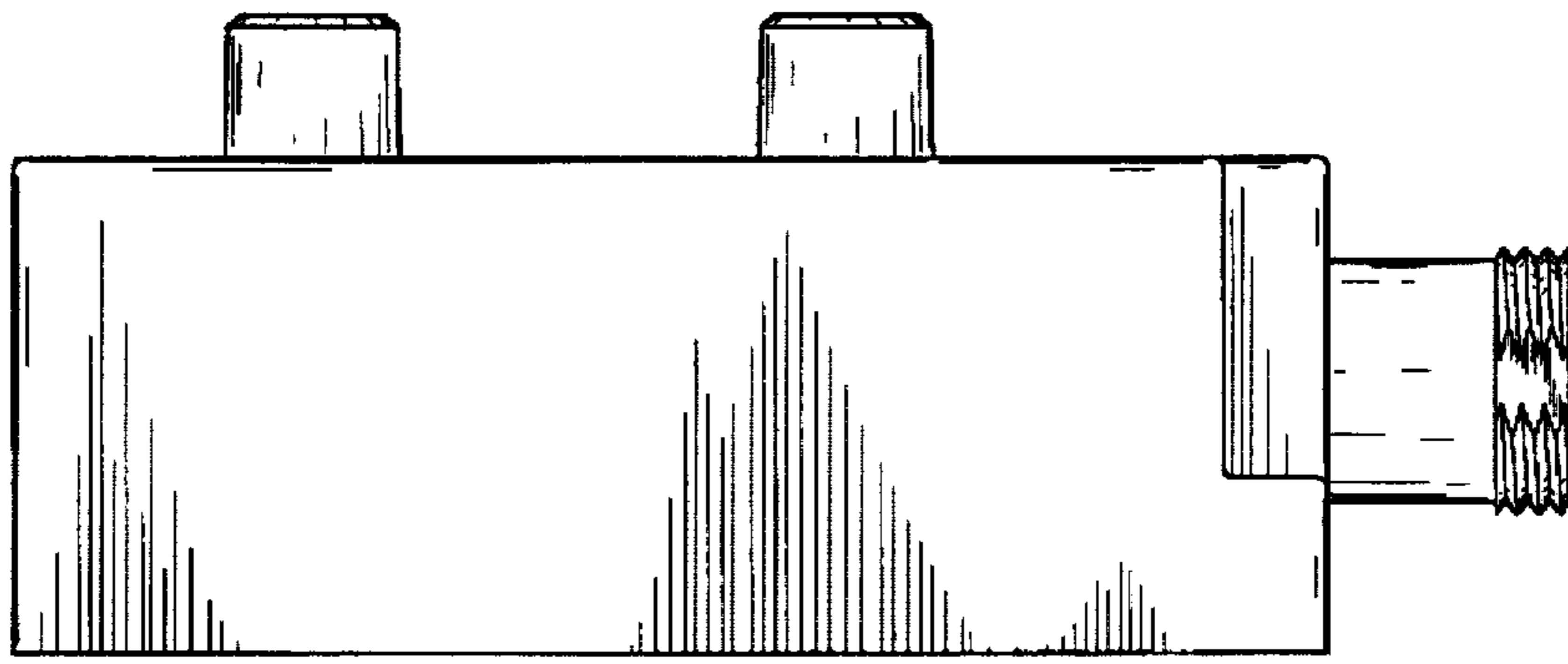

Fig.4

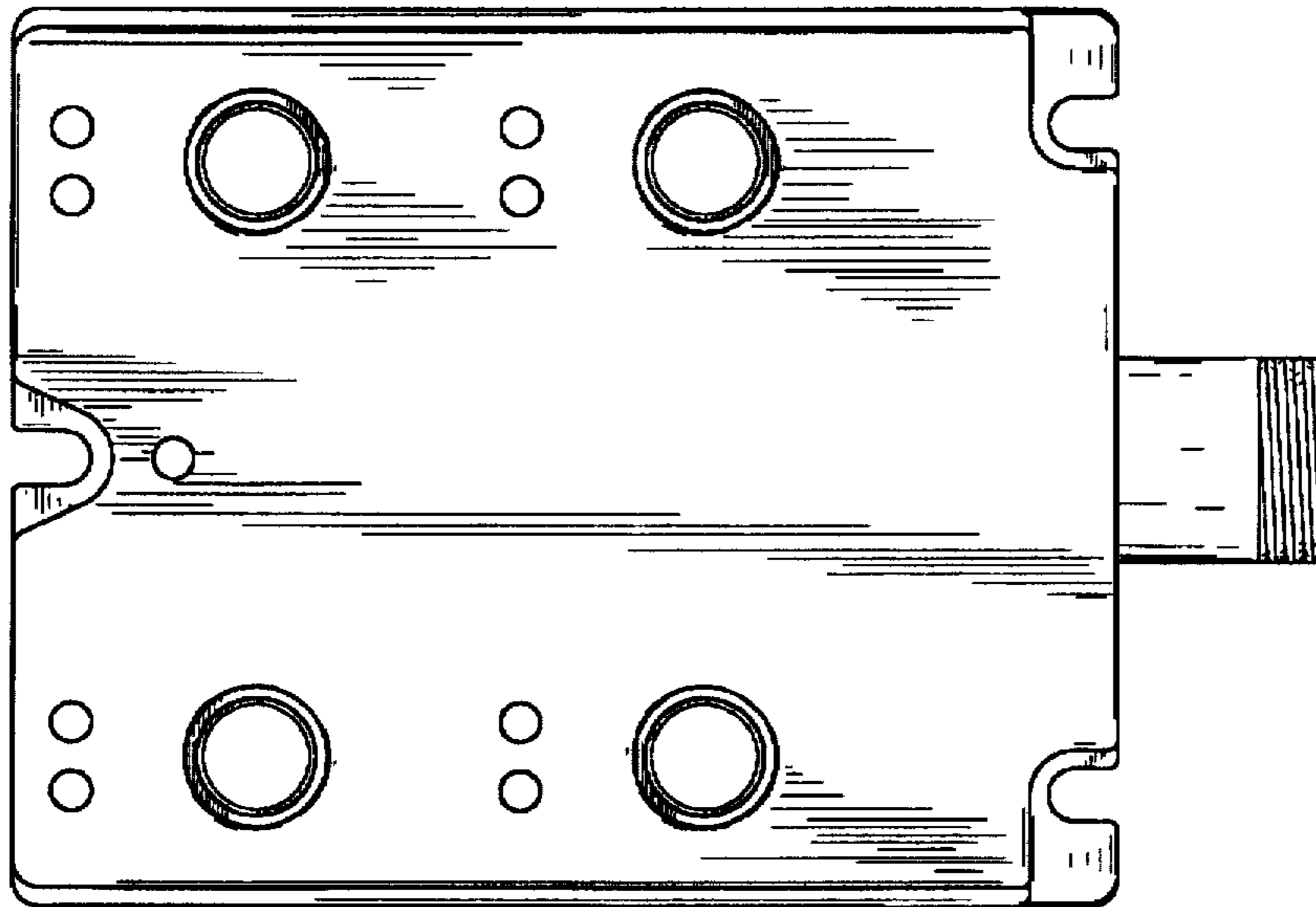

Fig.5

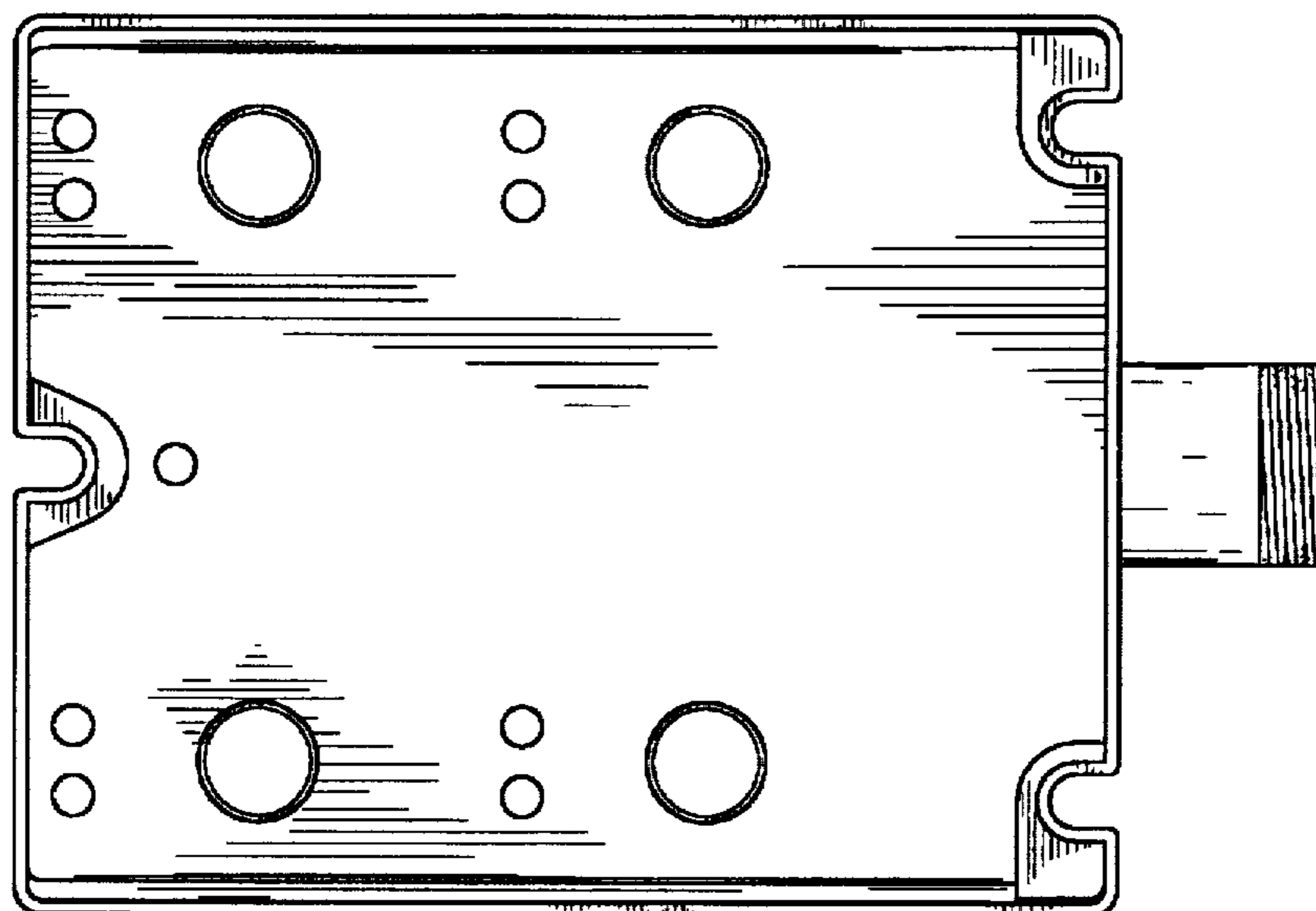

Fig.6