



US00D390525S

United States Patent [19]

Antos et al.

[11] Patent Number: Des. 390,525

[45] Date of Patent: **Feb. 10, 1998

[54] RV DOOR UNIT

[75] Inventors: **John M. Antos**, Ann Arbor; **John R. Selina**; **David B. Cameron**, both of Brighton; **James M. Byrne**, Ann Arbor, all of Mich.; **Gerard Cornelis Rijn. Arend**; **Marinus Antonius Ros**, Havik, both of Netherlands

[73] Assignee: **Thetford Corporation**, Ann Arbor, Mich.

[**] Term: **14 Years**

[21] Appl. No.: **52,467**

[22] Filed: **Apr. 2, 1996**

[51] LOC (6) Cl. **12-16**

[52] U.S. Cl. **D12/196**

[58] Field of Search D12/196, 100, D12/193; 292/35, DIG. 43, 37.1; 16/366; 49/395

[56] References Cited

U.S. PATENT DOCUMENTS

D. 219,774	1/1971	Cox	D12/193
D. 259,190	5/1981	Rowe	D12/100
D. 301,863	6/1989	Charet et al.	D12/193
D. 367,459	2/1996	Spencer	D12/193
4,906,033	3/1990	Sargent et al.	292/35

OTHER PUBLICATIONS

RV Business, Nov. 14, 1988, p. 73, the Hawkins Motor Coach Door Unit.

RV Business, Nov. 6, 1989, p. 26, the Cross Country L5 Motor home door unit.

Brochure entitled "Arco Solar", 1988 RV Business, p. 13. Brochure entitled "Titan Motor Homes".

Brochure entitled "Komfort", Jun., 1988 RV Business, p. 53.

Primary Examiner—Melody N. Brown

Attorney, Agent, or Firm—Harness, Dickey & Pierce, P.L.C.

[57] CLAIM

The ornamental design for a RV door unit, as shown and described.

DESCRIPTION

FIG. 1 is a perspective view of a RV door unit showing our new design mounted on a side wall of a RV, it being understood that the broken lines are for illustrative purposes only of the RV and form no part of the claimed design;

FIG. 2 is a greatly enlarged front elevational view of the door unit shown in FIG. 1;

FIG. 3 is a greatly enlarged top view of the door unit shown in FIG. 1;

FIG. 4 is a greatly enlarged end elevational view of the door unit shown in FIG. 1; and,

FIG. 5 is a greatly enlarged bottom view of the door unit shown in FIG. 1.

1 Claim, 2 Drawing Sheets

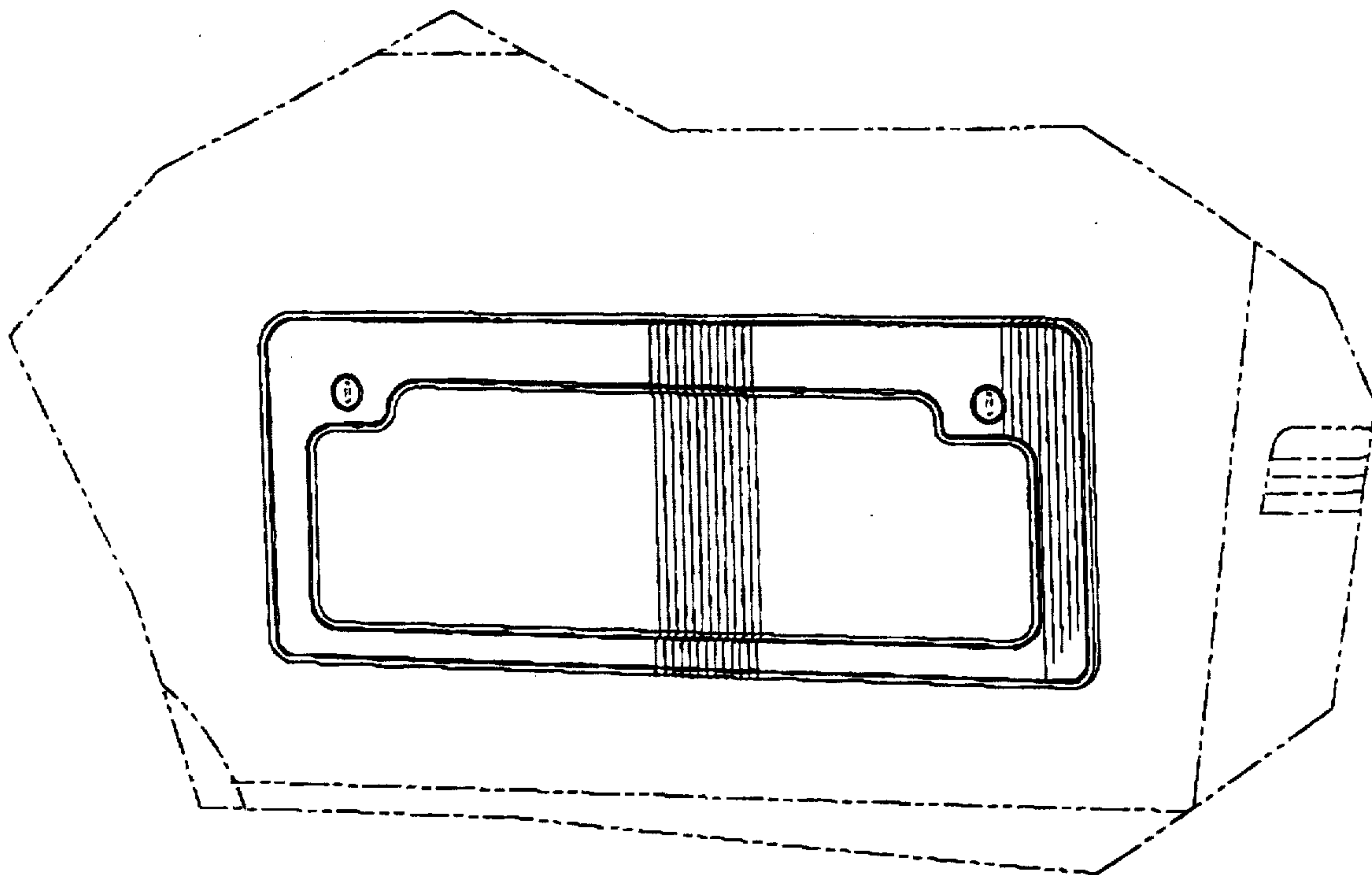

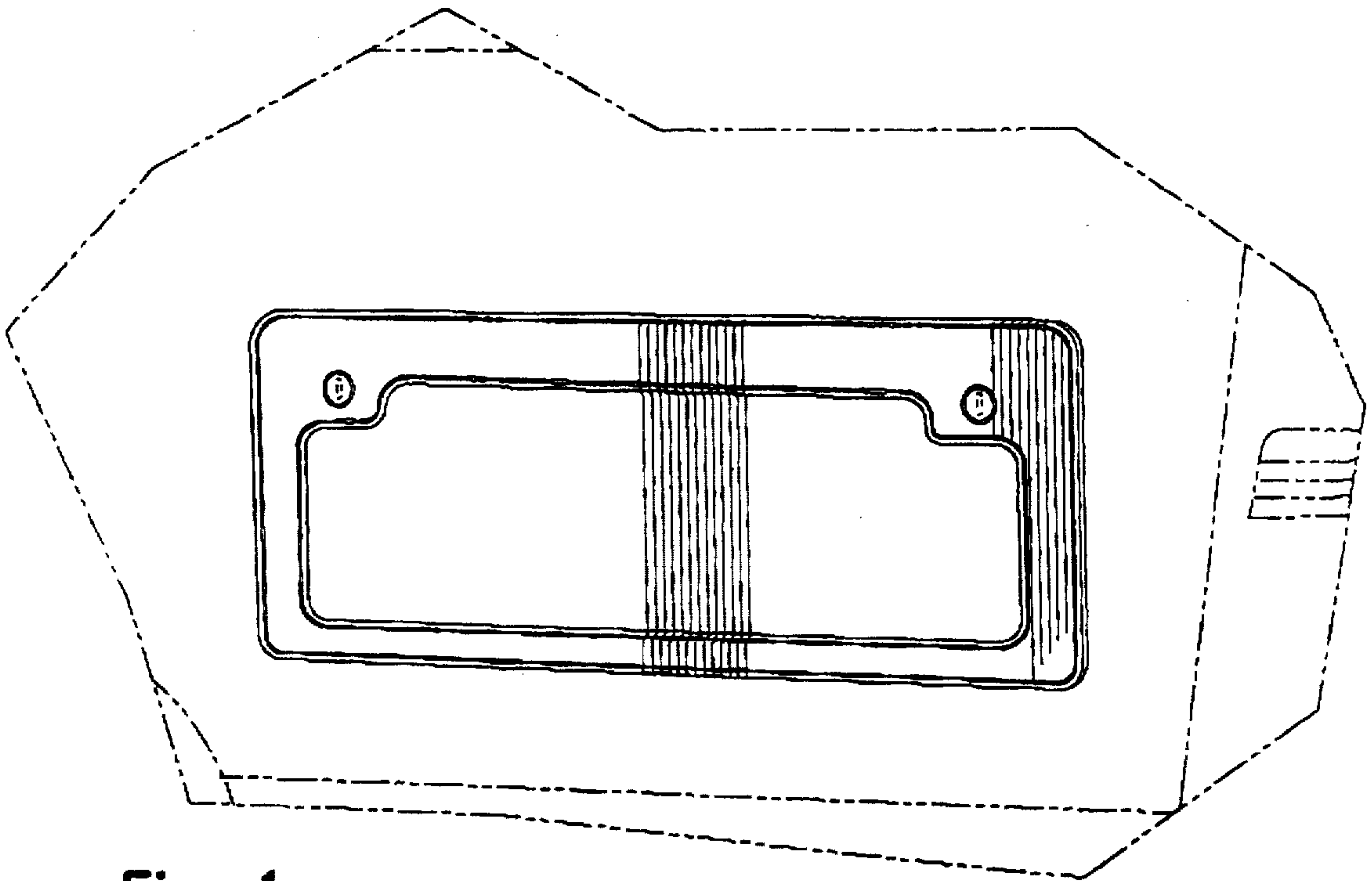

Fig-1

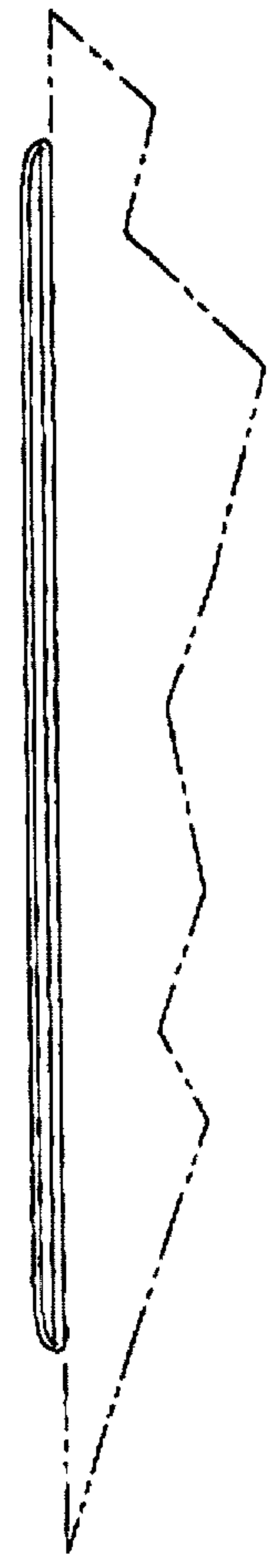

Fig-4

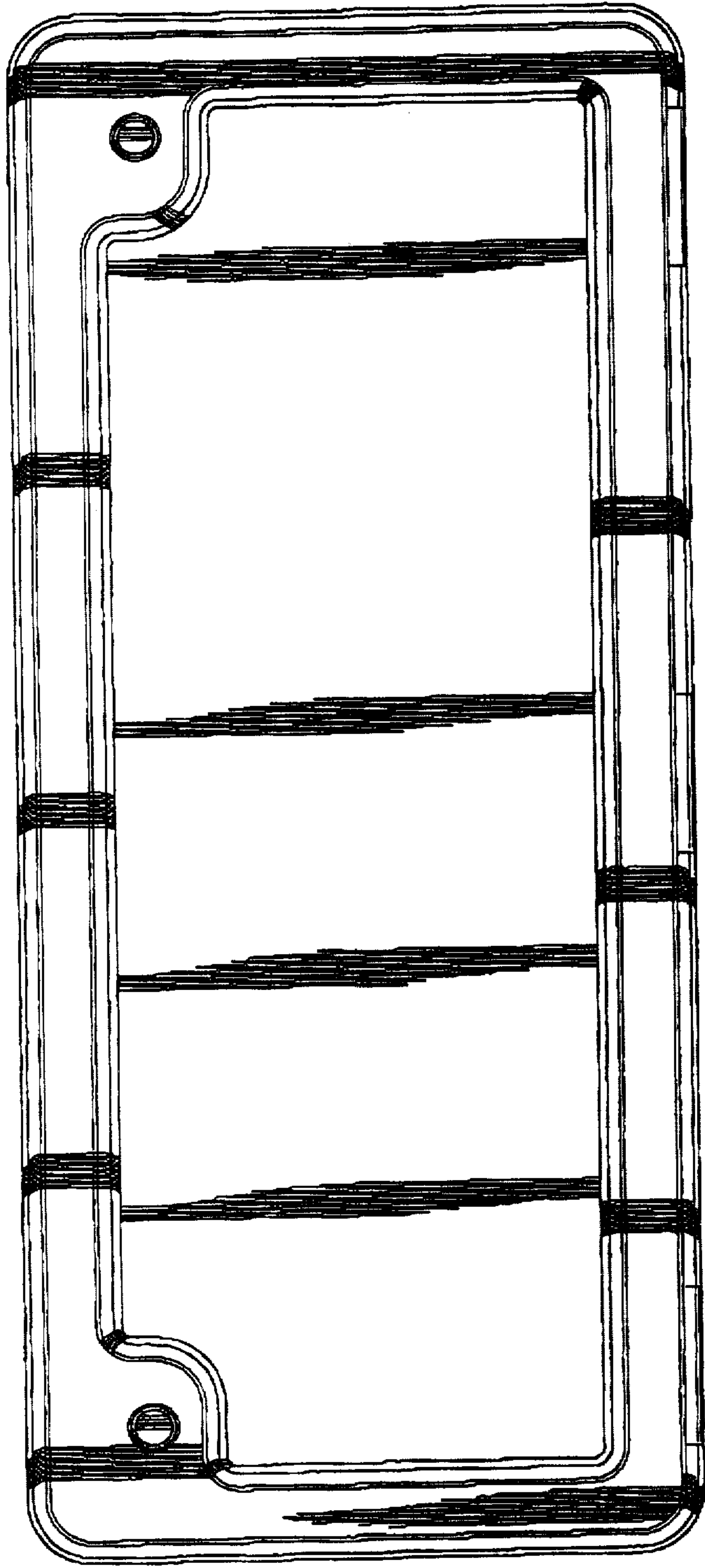

Fig-2

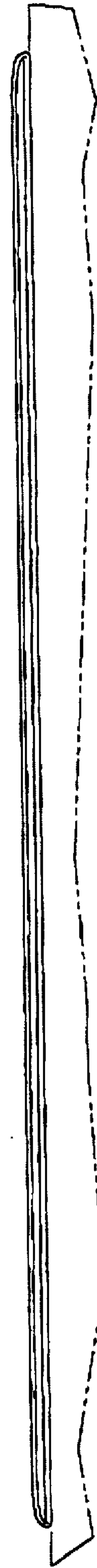

Fig-3

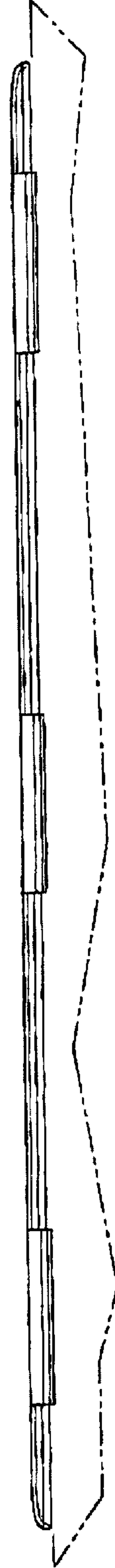

Fig-5