

US00D390188S

United States Patent [19]

Norfolk et al.

[11] Patent Number: **Des. 390,188**

[45] Date of Patent: ****Feb. 3, 1998**

[54] **BOAT LIFT MOTOR AND GEAR HOUSING**

4,836,124 6/1989 Haasl 114/285
4,895,095 1/1990 Potter, Jr. 114/343

[75] Inventors: **Lynn P. Norfolk; David Charles Peterson, Jr.**, both of Edgewater; **Ronald Price Ranere**, Chesapeake Beach; **Russell V. Welton**, Grasonville, all of Md.

Primary Examiner—James Gandy
Assistant Examiner—Cathron B. Matta
Attorney, Agent, or Firm—Diller, Ramik & Wight, PC

[57] **CLAIM**

The ornamental design for a boat lift motor and gear housing, as shown and described.

[73] Assignee: **Norfolk Fabrication, Inc.**, Mayo, Md.

[**] Term: **14 Years**

DESCRIPTION

[21] Appl. No.: **57,044**

FIG. 1 is a rear perspective view of a boat lift motor and gear housing showing our new design;

[22] Filed: **Jul. 15, 1996**

FIG. 2 is a side elevational view thereof, shown at a slightly enlarged scale;

[51] LOC (6) Cl. **13-02**

FIG. 3 is a side elevational view opposite that shown in FIG. 2;

[52] U.S. Cl. **D13/112**

FIG. 4 is a rear elevational view thereof, shown at a slightly enlarged scale;

[58] Field of Search D13/112, 114, D13/116, 184; 114/271, 284-286, 343, 355-357, 361; 248/637, 640-643; 440/900; 310/83, 89; 405/3

FIG. 5 is a front elevational view thereof, shown at a slightly enlarged scale;

[56] **References Cited**

U.S. PATENT DOCUMENTS

- D. 310,348 9/1990 Higuchi et al. D13/114
- D. 321,680 11/1991 Blount et al. D13/184 X
- 4,075,971 2/1978 Reginensi 440/54
- 4,678,366 7/1987 Williamson 405/3
- 4,757,971 7/1988 Mapes 248/642

FIG. 6 is a top plan view thereof, shown at a slightly enlarged scale; and,

FIG. 7 is a bottom plan view thereof, shown at a slightly enlarged scale.

The broken line showing of environmental structure is for illustrative purposes only and forms no part of the claimed design.

1 Claim, 2 Drawing Sheets

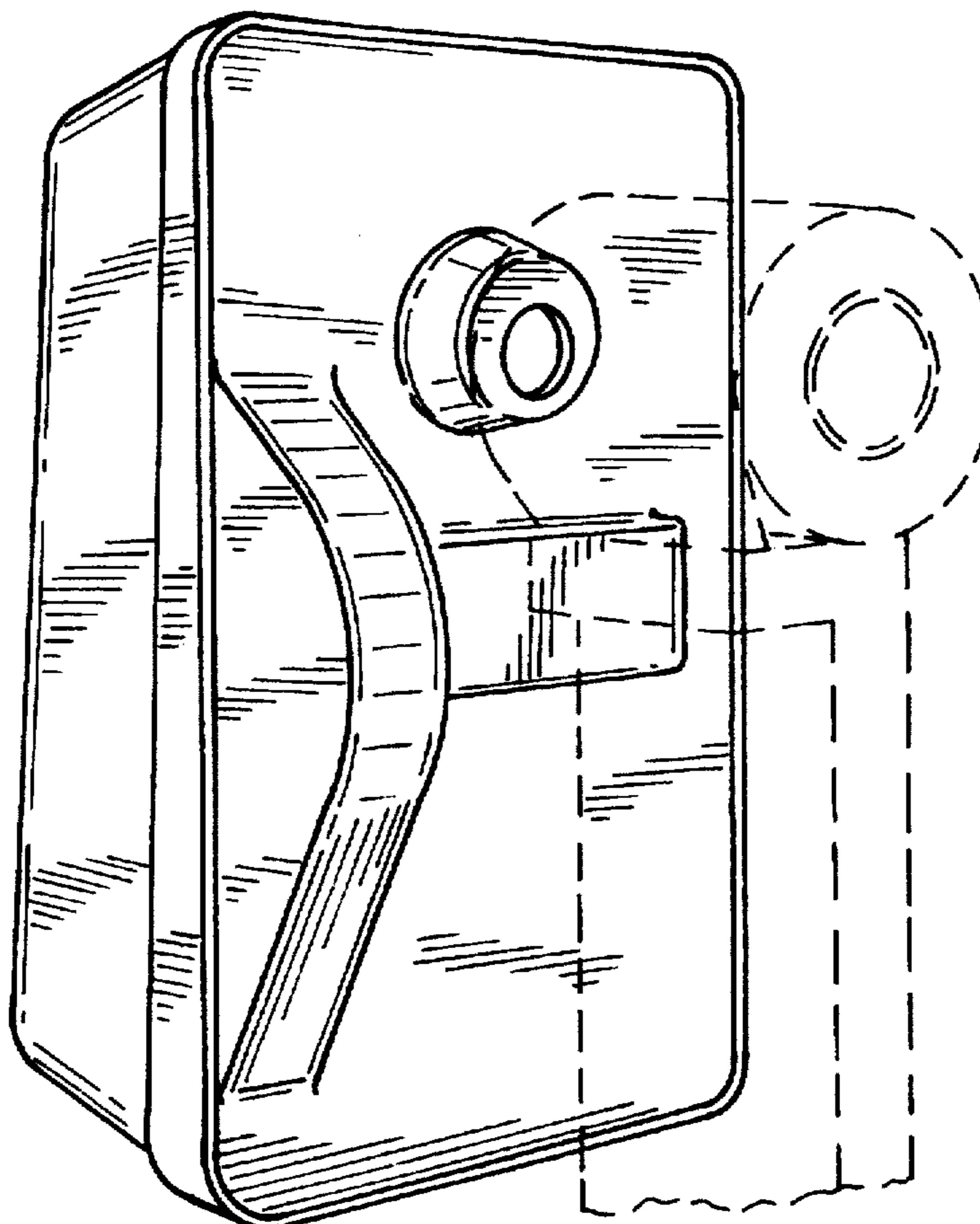

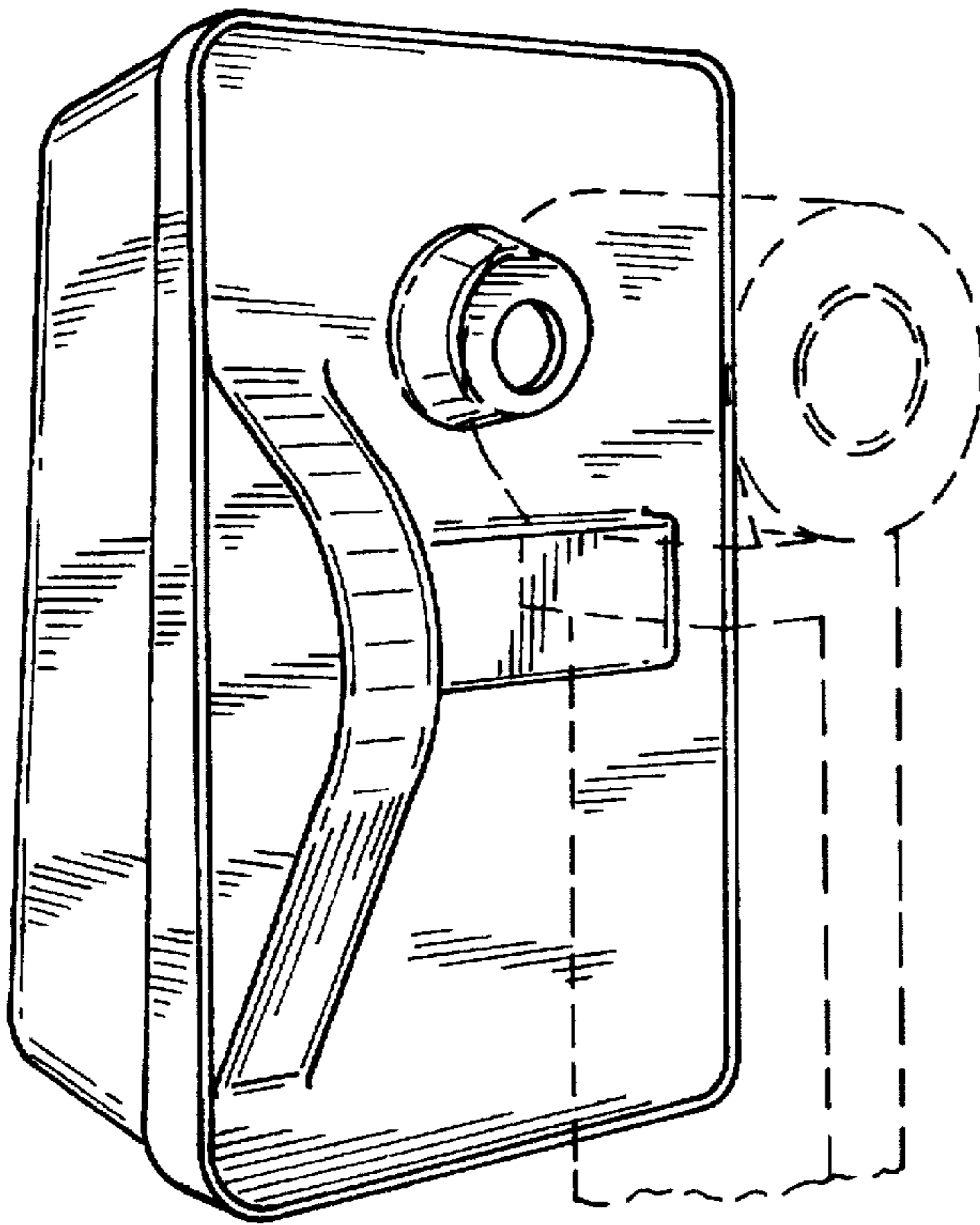

FIG. 1

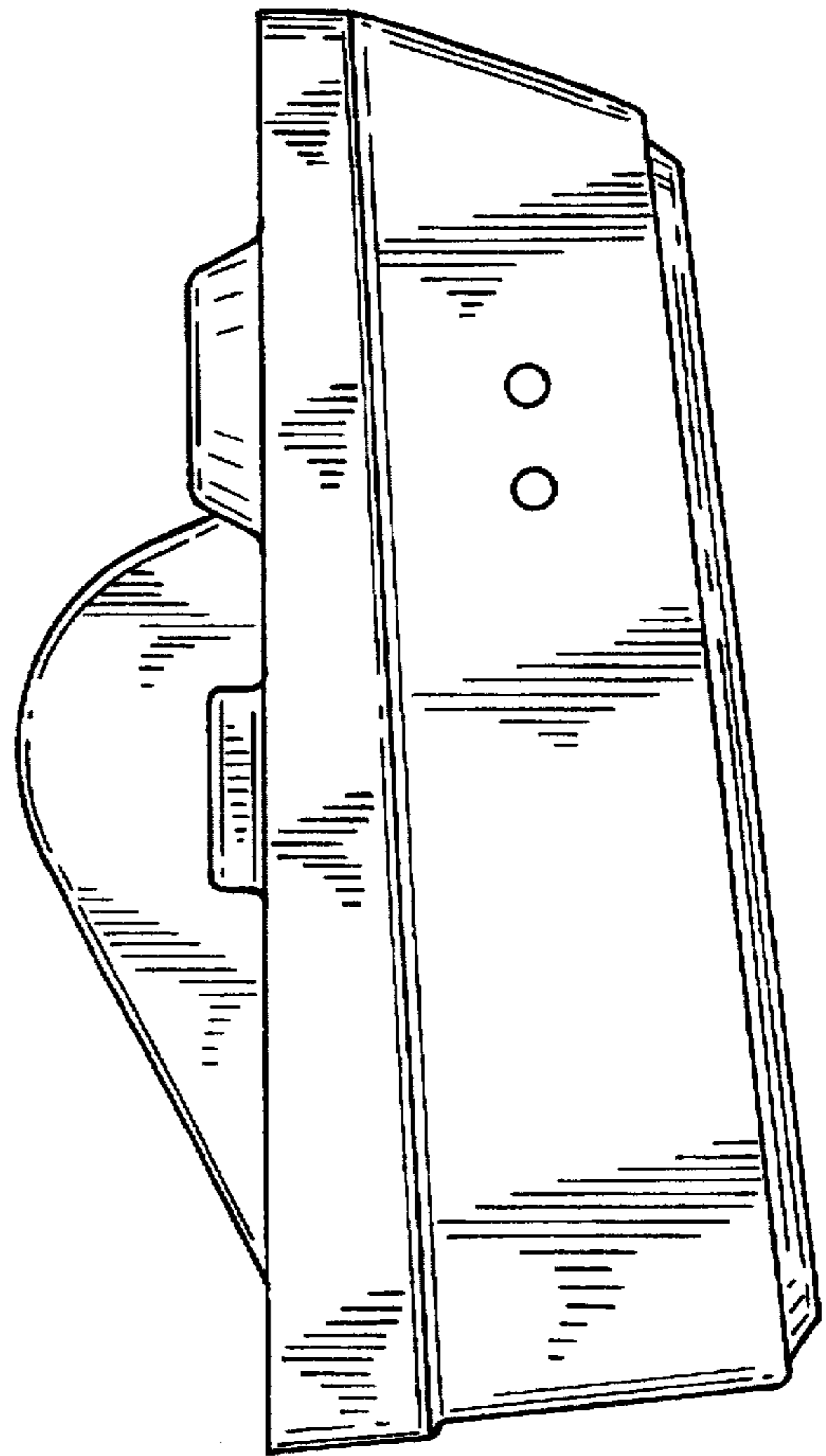

FIG. 2

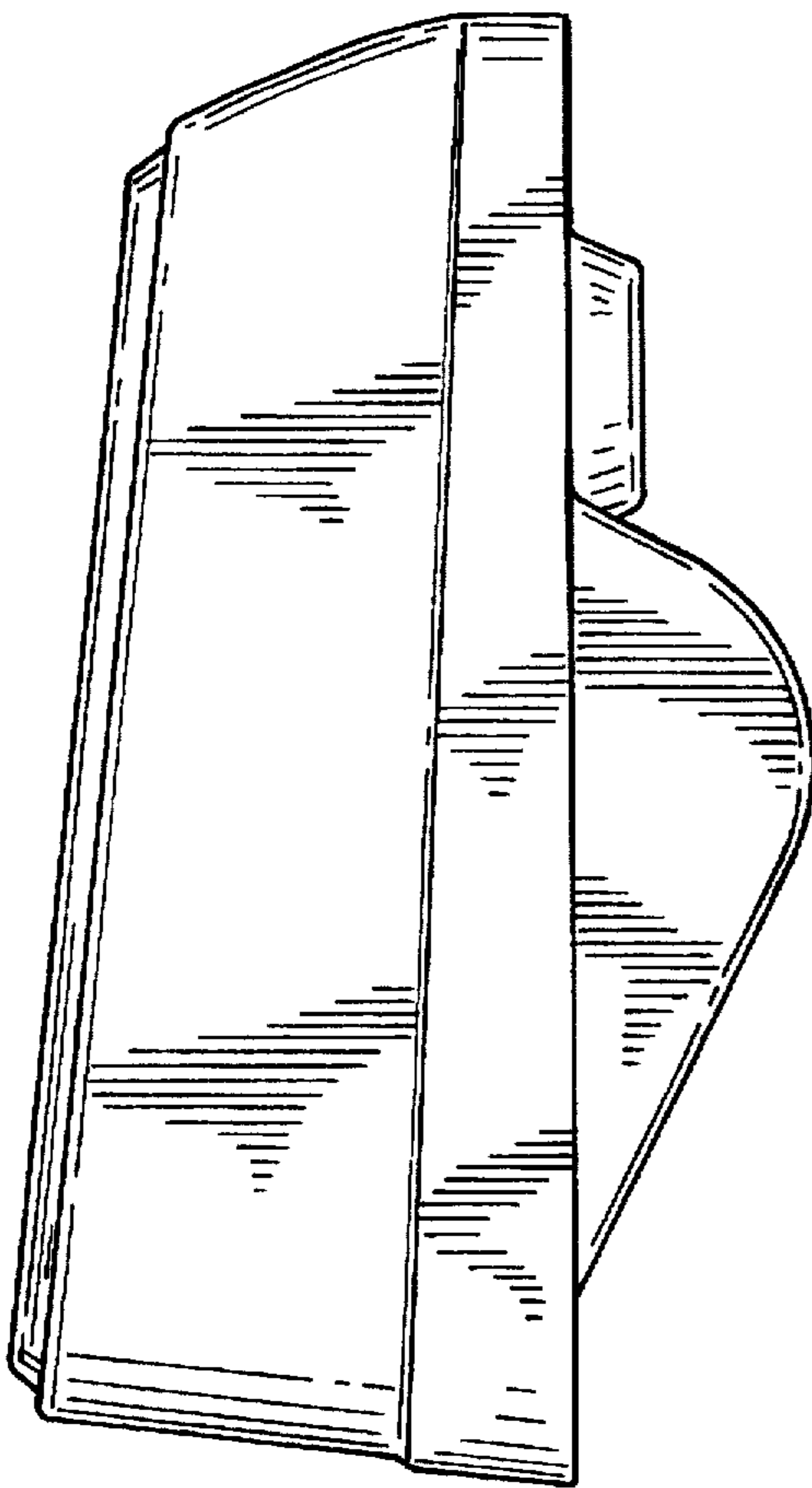

FIG. 3

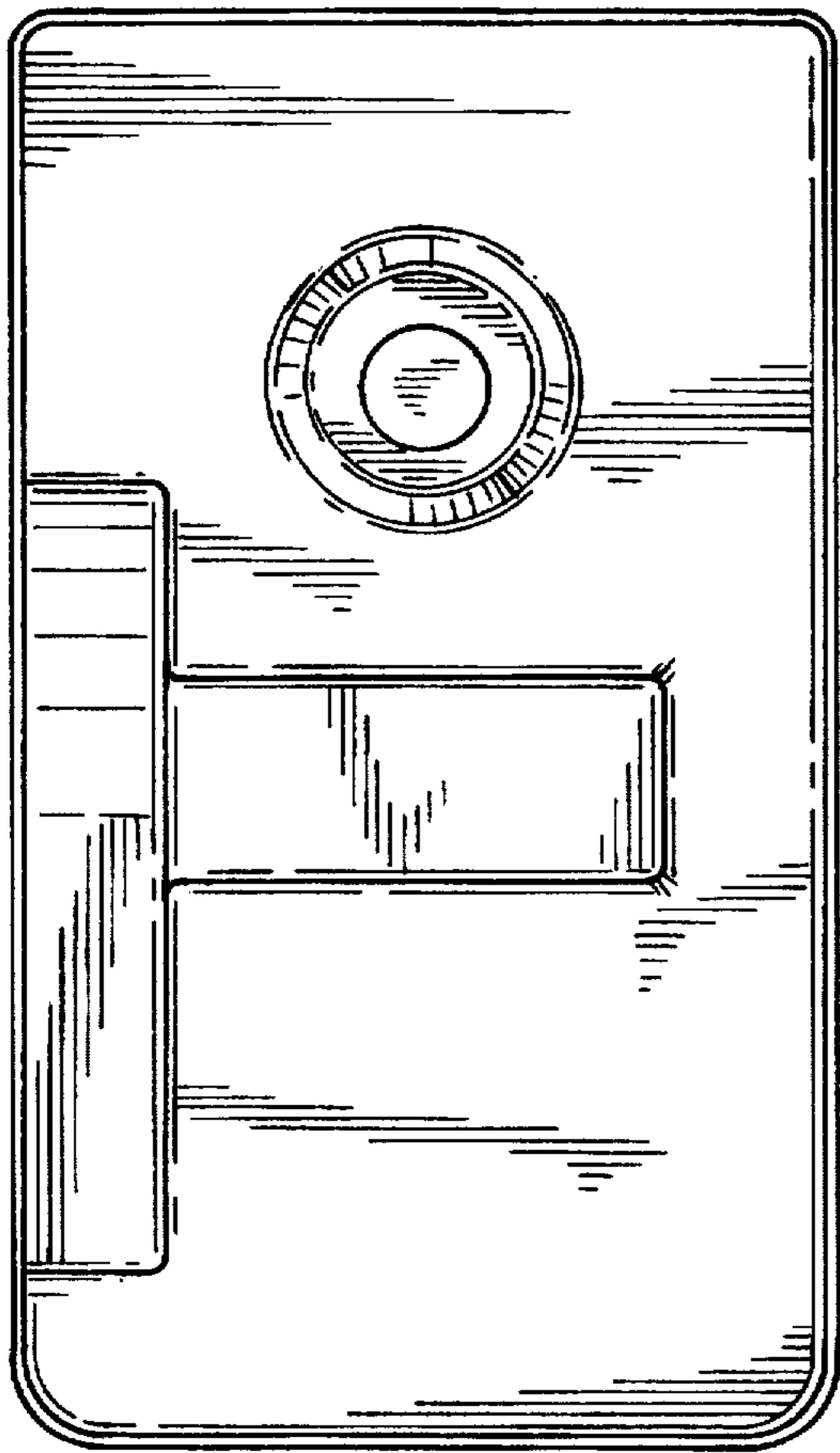

FIG. 4

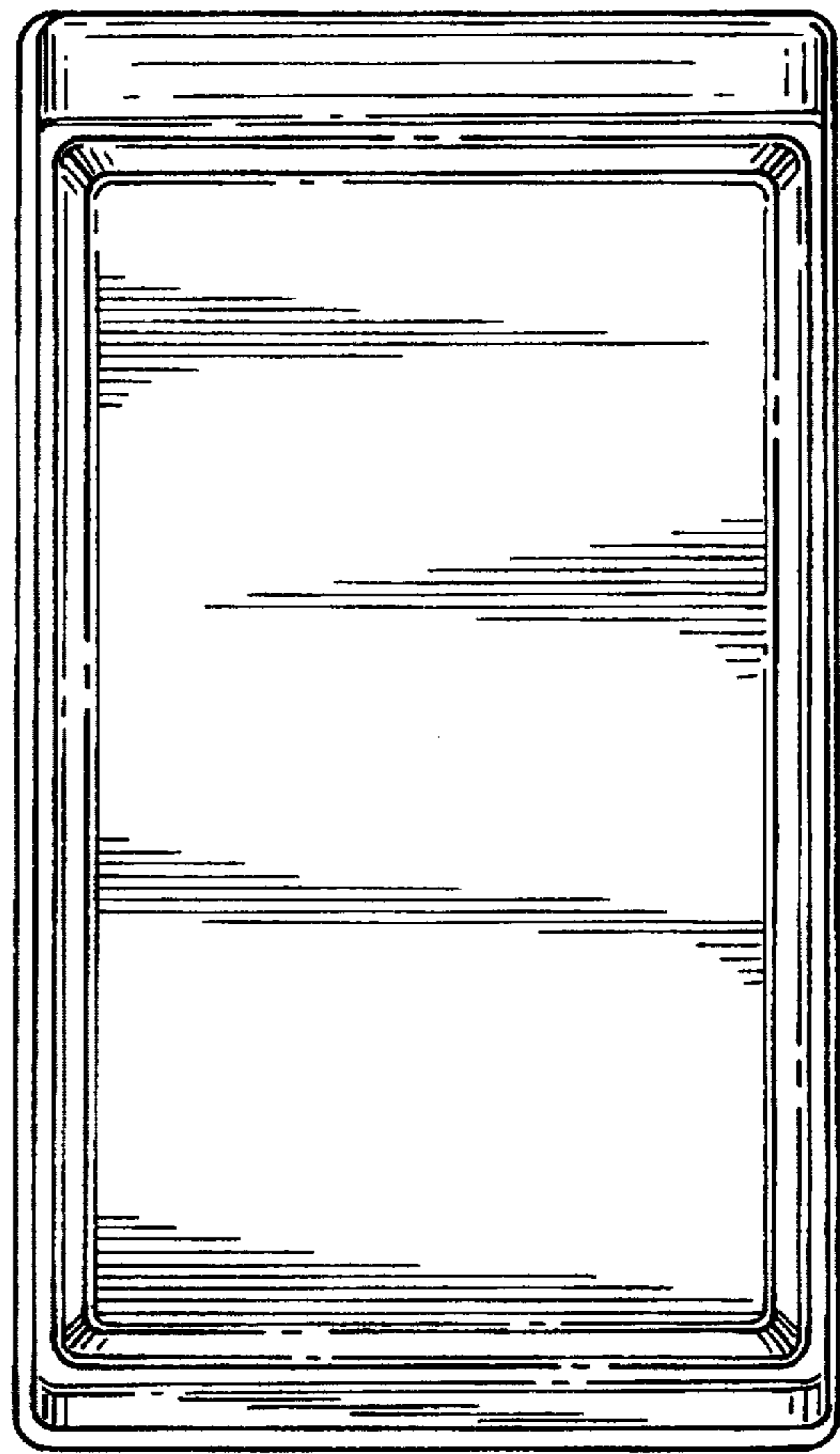

FIG. 5

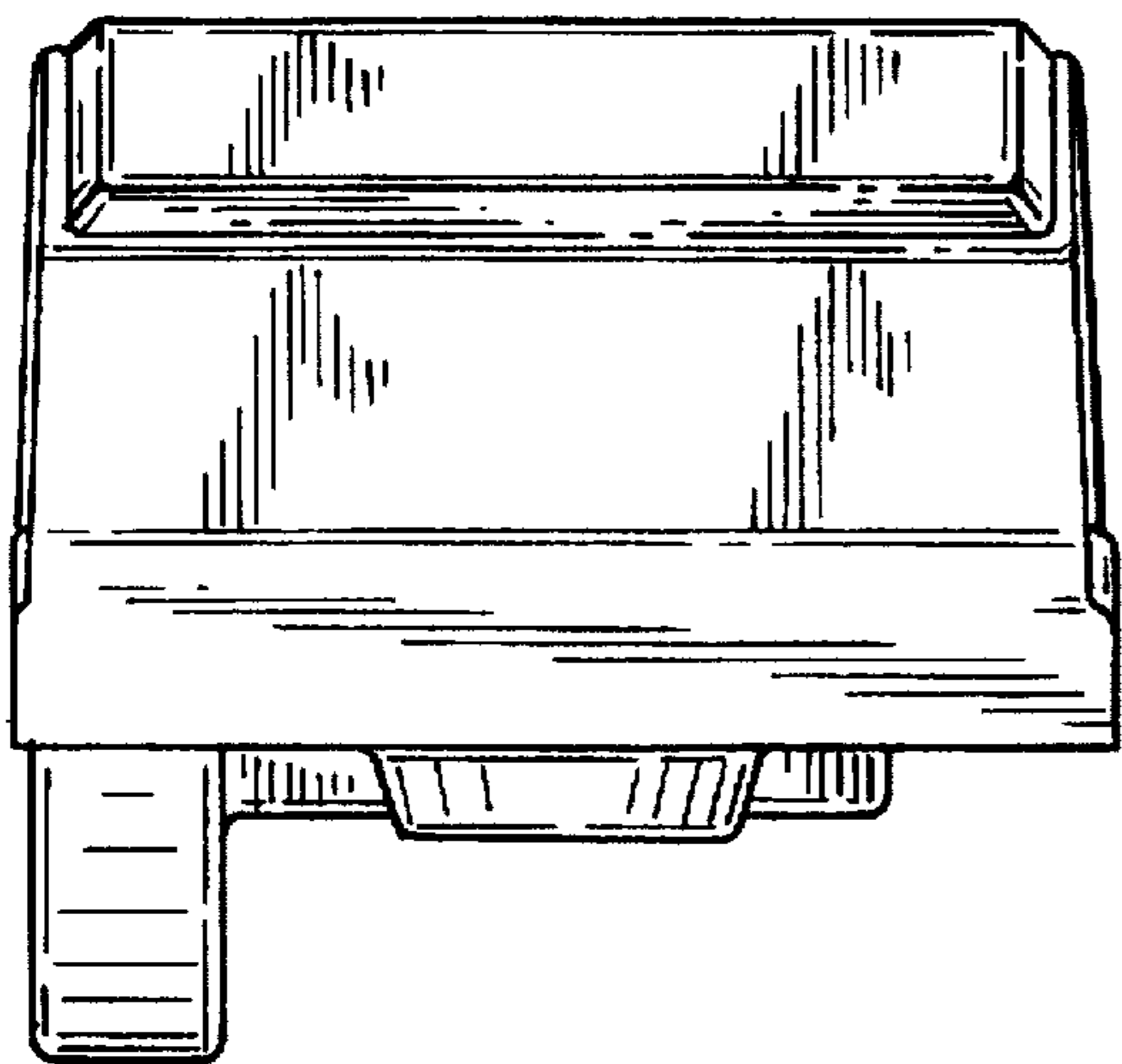

FIG. 6

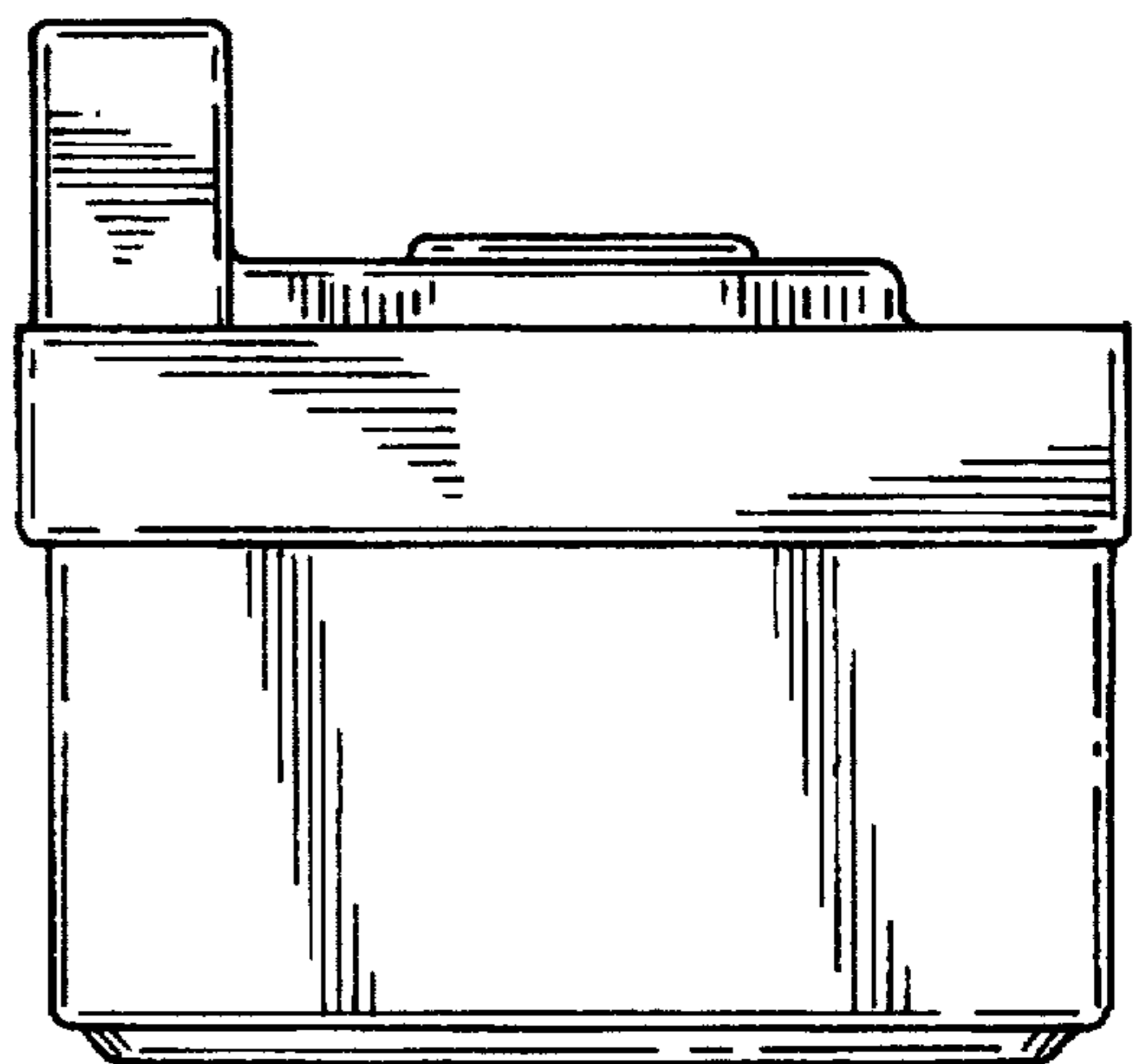

FIG. 7