



US00D389968S

United States Patent [19]
Sham

[11] **Patent Number: Des. 389,968**
[45] **Date of Patent: **Jan. 27, 1998**

[54] **TRAVEL STEAM IRON**

[76] **Inventor: John C. K. Sham**, Rm. 1508, Block C,
19 Broadwood Rd., Hong Kong, Hong
Kong

[**] **Term: 14 Years**

[21] **Appl. No.: 44,561**

[22] **Filed: Sep. 26, 1995**

[51] **LOC (6) Cl. 07-05**

[52] **U.S. Cl. D32/70**

[58] **Field of Search D32/68, 69, 70,**
D32/71, 72, 73; 219/245, 246, 247; 38/69,
74, 77.1-77.9, 79, 88

[56] **References Cited**

U.S. PATENT DOCUMENTS

D. 283,934	5/1986	Tsuji	D32/69
D. 286,095	10/1986	Van Asten	D32/69
D. 290,889	7/1987	Steinkamp	D32/70
D. 291,614	8/1987	Roberts et al.	D32/69
D. 292,536	10/1987	Tsuji	D32/69
D. 296,255	6/1988	Chan	D32/69
D. 315,433	3/1991	Chen	D27/68
D. 327,150	6/1992	Gudefin et al.	D32/70
D. 362,944	10/1995	Sham et al.	D32/70
4,484,399	11/1984	Biancalani	D32/68 X

FOREIGN PATENT DOCUMENTS

61-257695 11/1986 Japan .

Primary Examiner—Susan J. Lucas
Assistant Examiner—Cynthia E. Ramirez
Attorney, Agent, or Firm—Salzman & Levy

[57] **CLAIM**

The ornamental design for a travel steam iron, as shown and described.

DESCRIPTION

FIG. 1 illustrates a top, front and left side perspective view of my new design for a travel steam iron in the operating position;

FIG. 2 illustrates a top view thereof;

FIG. 3 illustrates a left side elevational view thereof;

FIG. 4 illustrates a right side elevational view thereof;

FIG. 5 illustrates a front elevational view thereof;

FIG. 6 illustrates a rear elevational view thereof;

FIG. 7 illustrates a bottom view thereof;

FIG. 8 illustrates a top, front and left side perspective view of my new design for a travel steam iron in the collapsed position;

FIG. 9 illustrates a top view of the iron of FIG. 8;

FIG. 10 illustrates a left side elevational view of the iron of FIG. 8;

FIG. 11 illustrates a right side elevational view of the iron of FIG. 8;

FIG. 12 illustrates a front elevational view of the iron of FIG. 8;

FIG. 13 illustrates a rear elevational view of the iron of FIG. 8; and,

FIG. 14 illustrates a bottom view of the iron of FIG. 8.

1 Claim, 7 Drawing Sheets

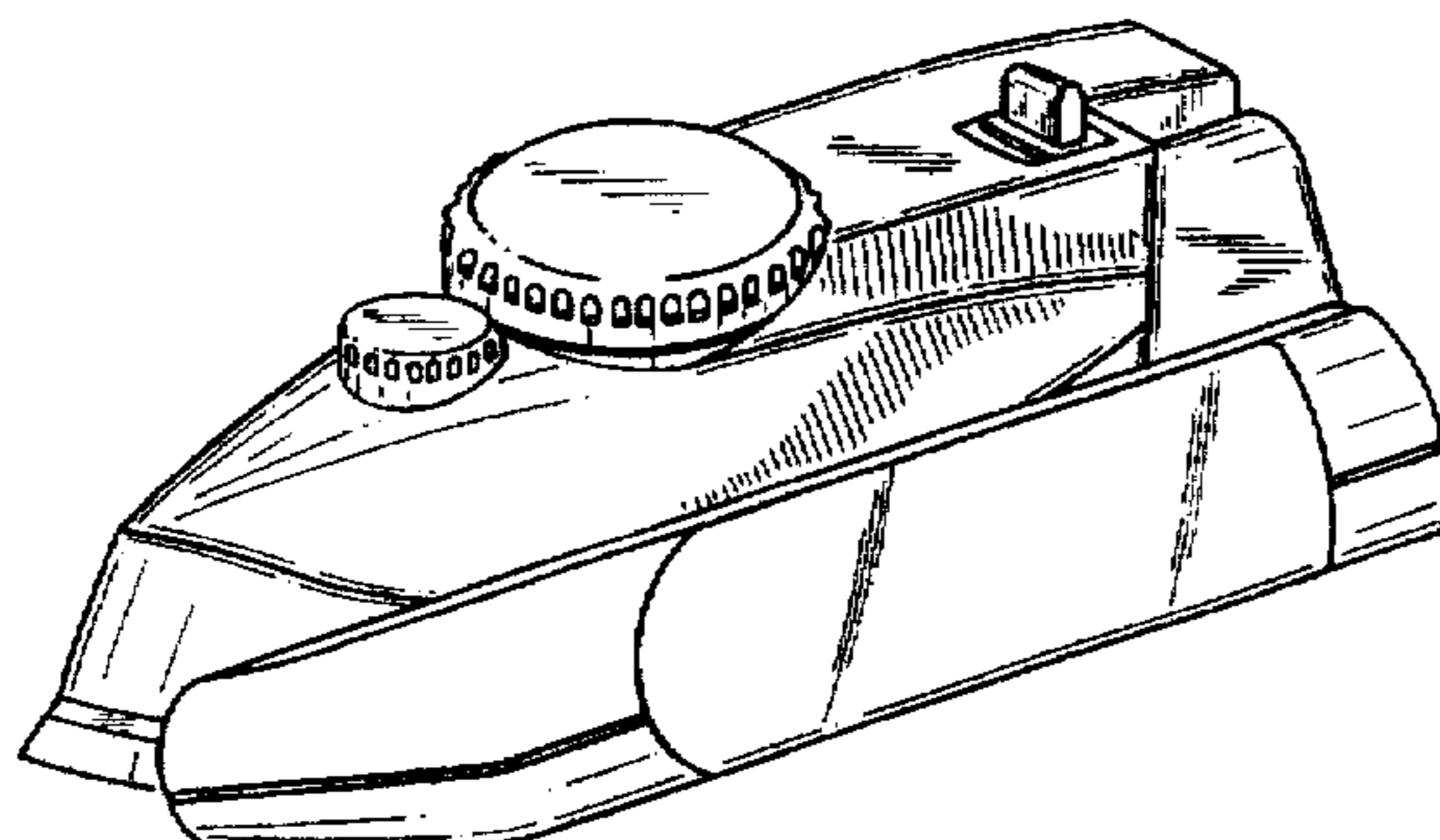
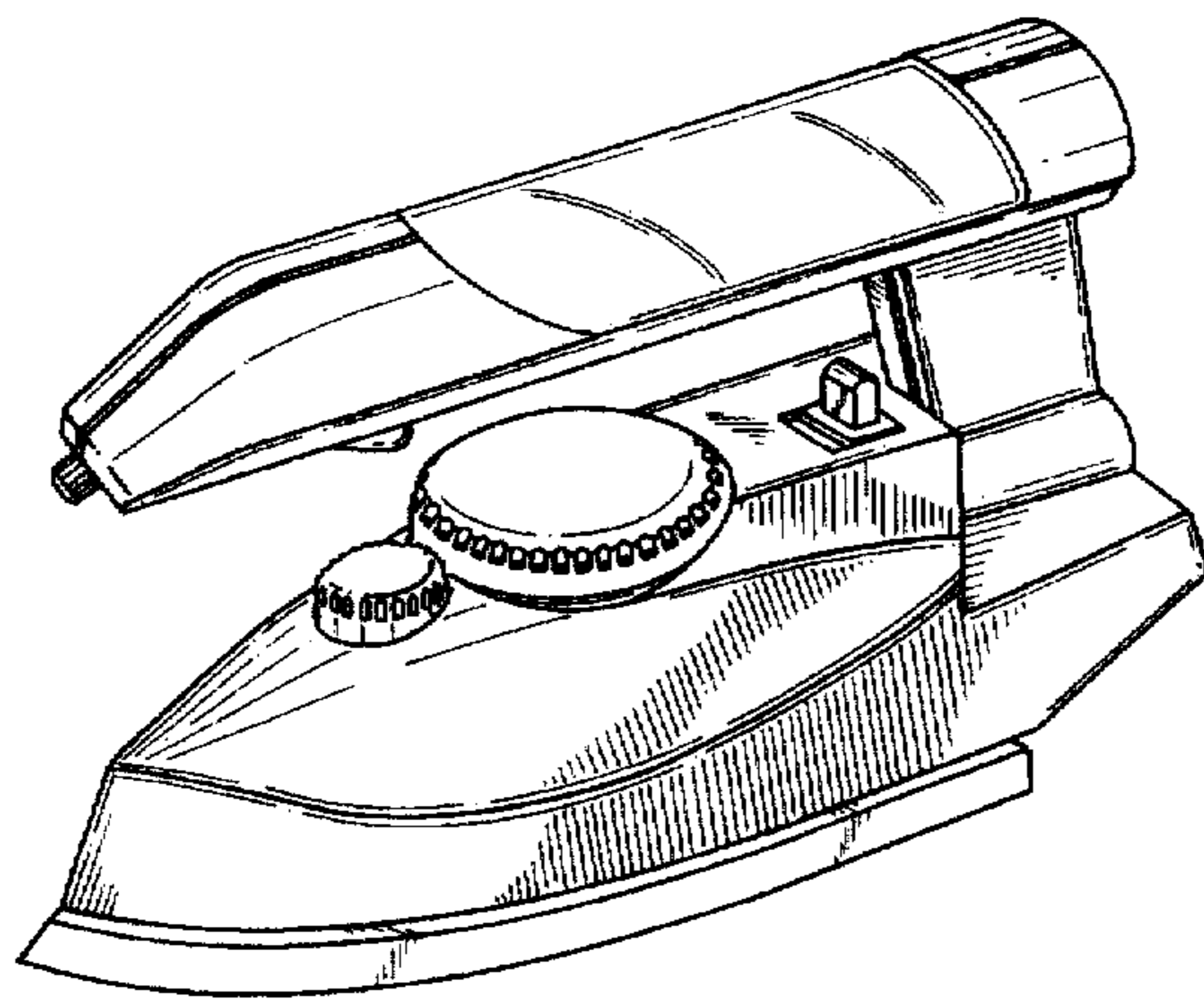

FIG. 1

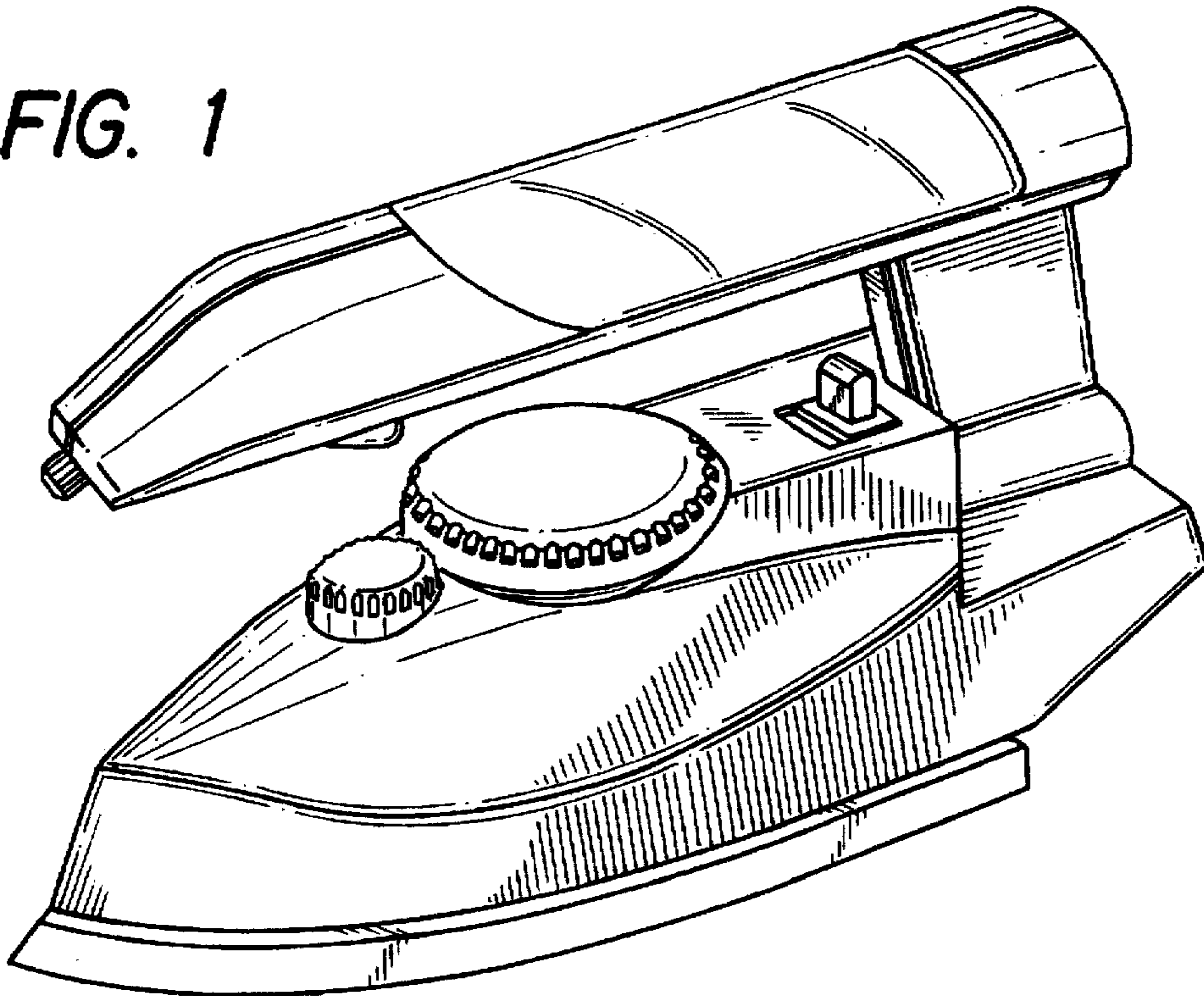

FIG. 2

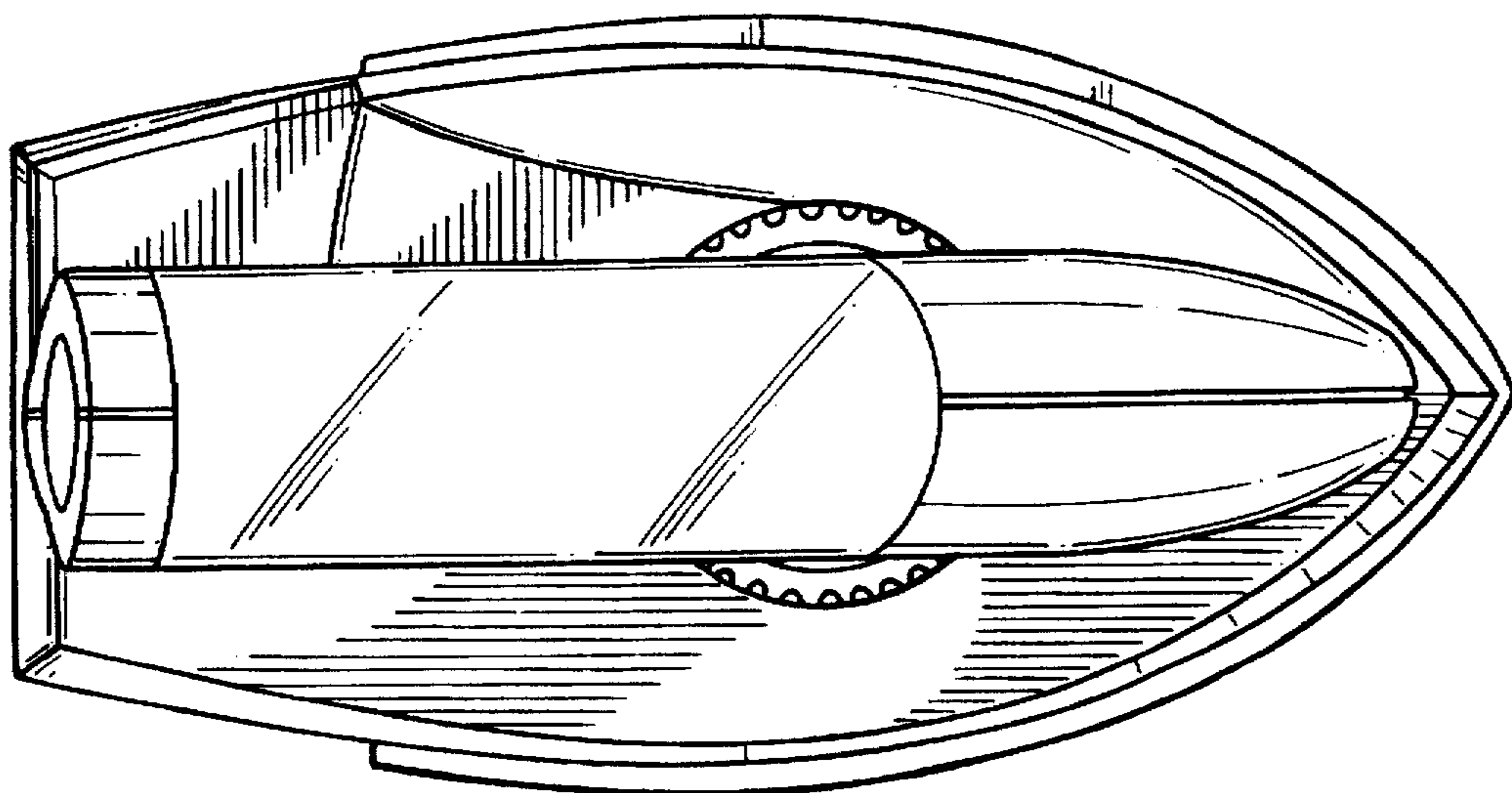

FIG. 3

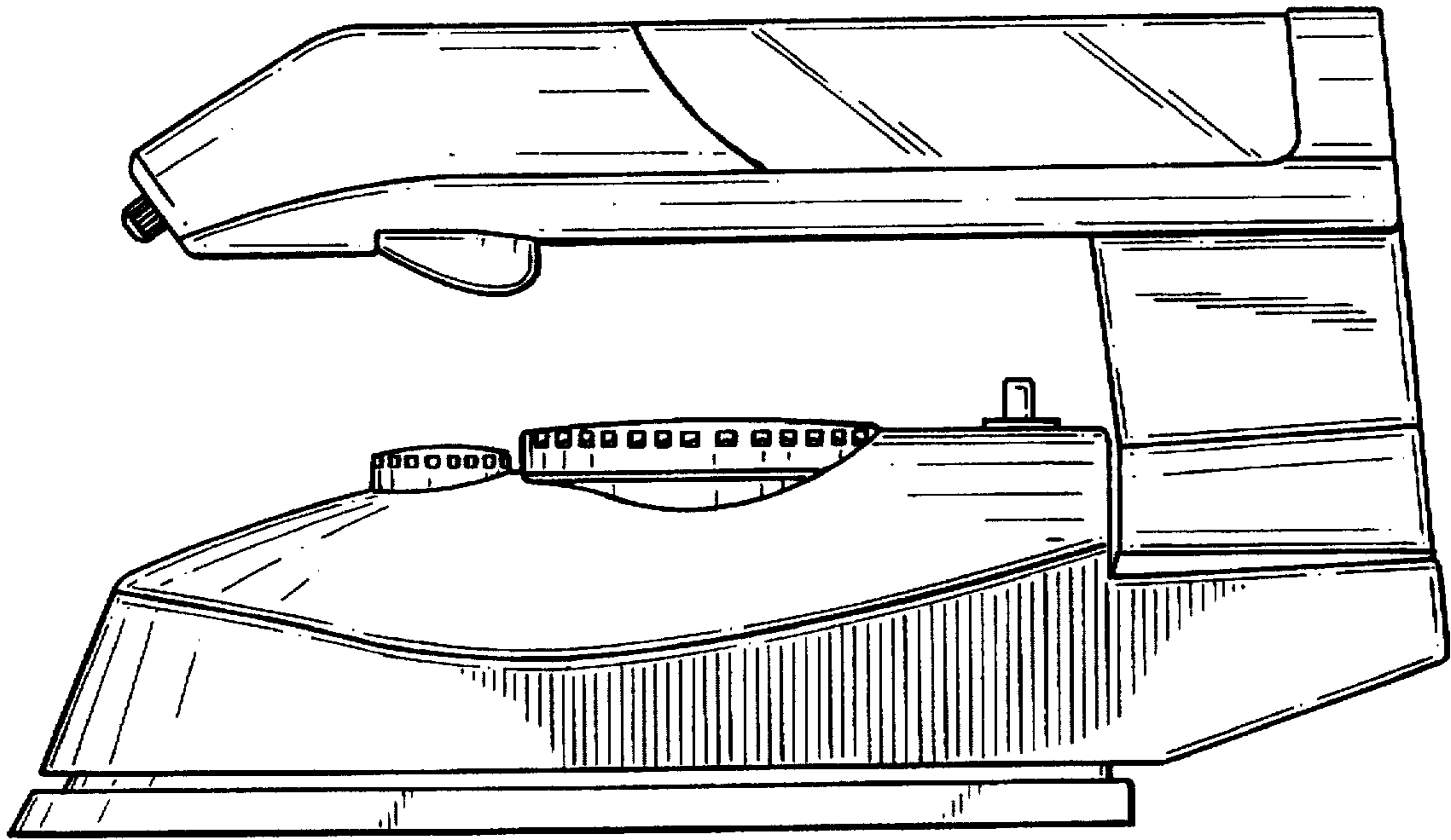

FIG. 4

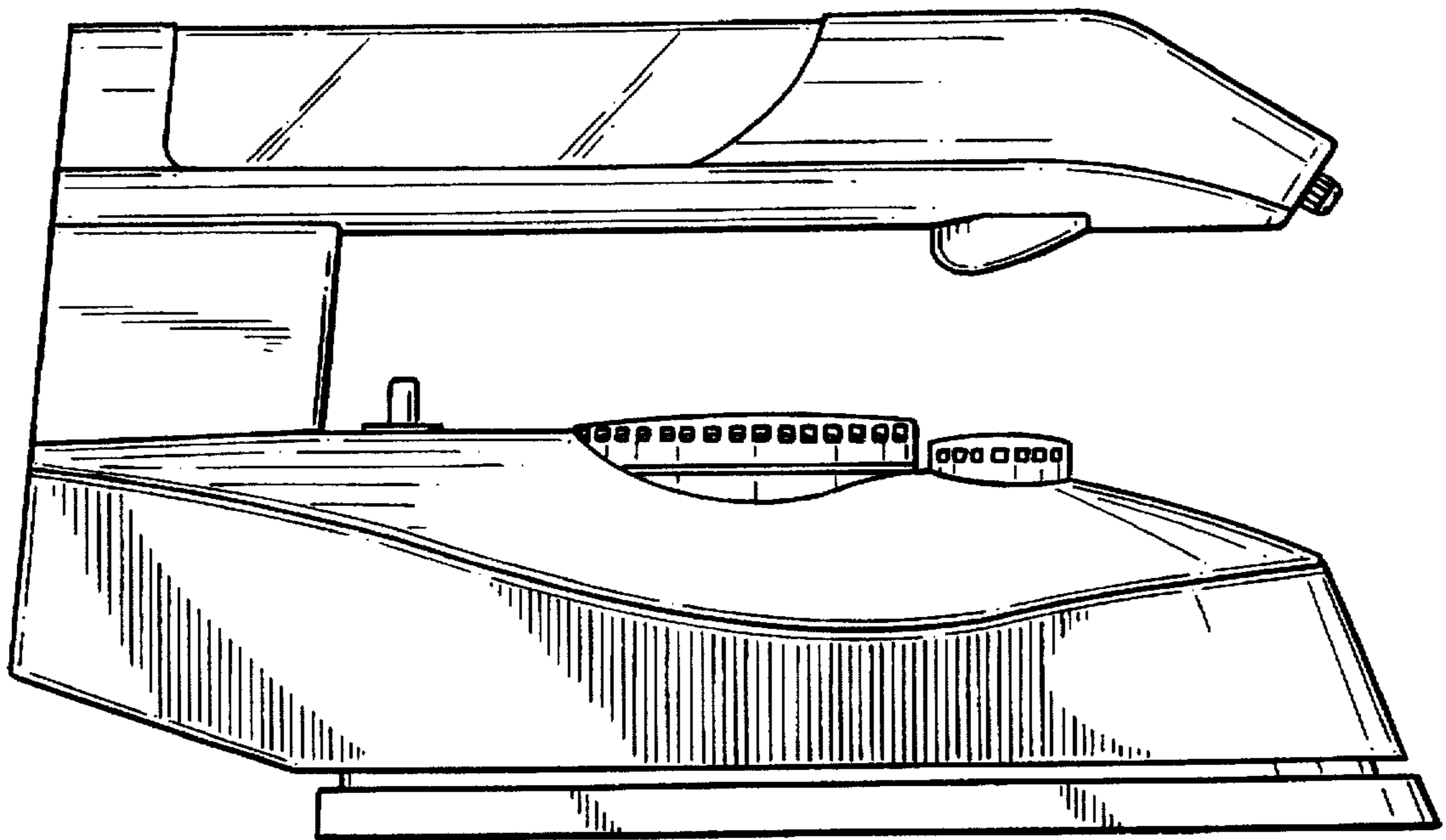

FIG. 5

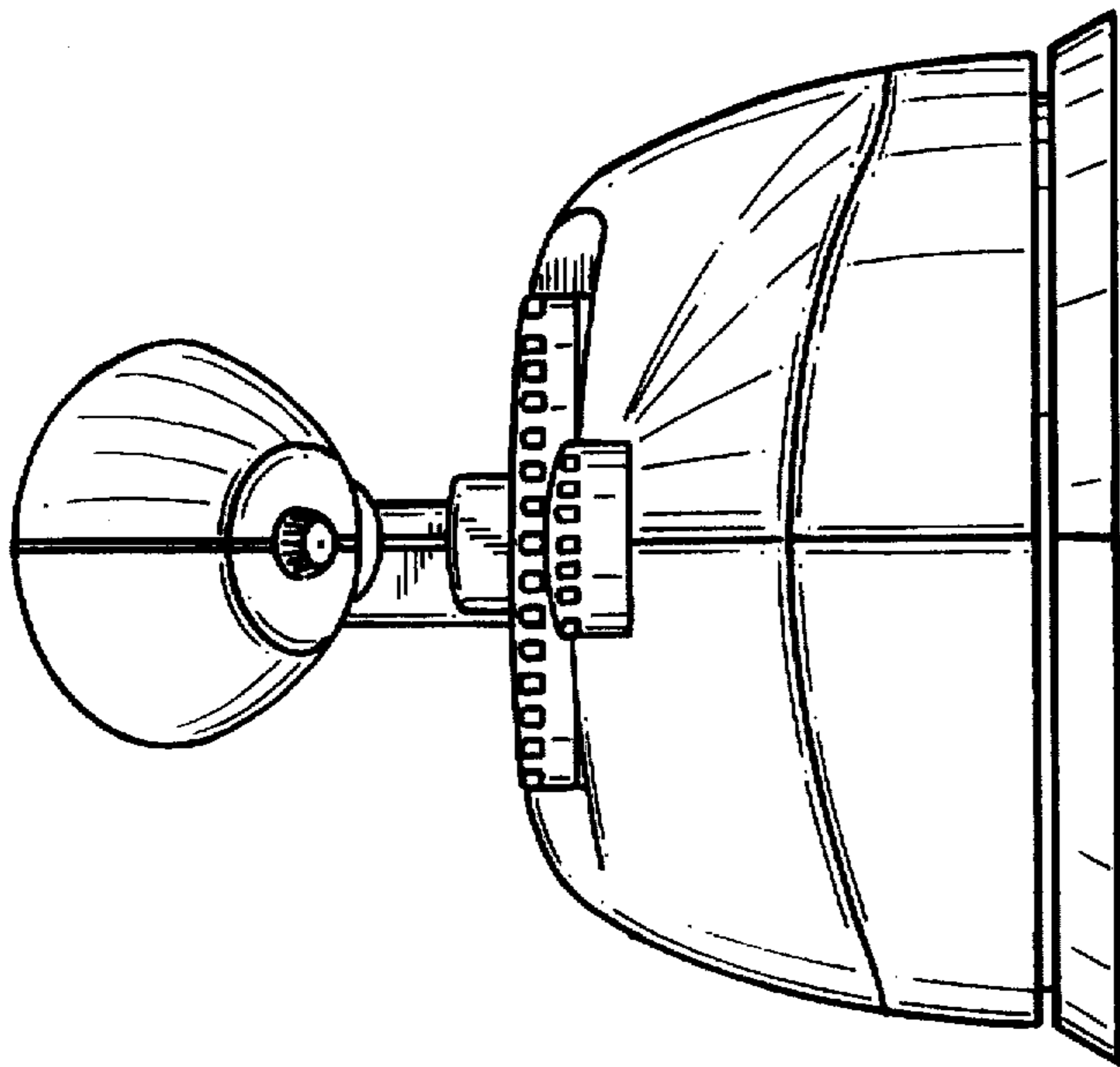

FIG. 6

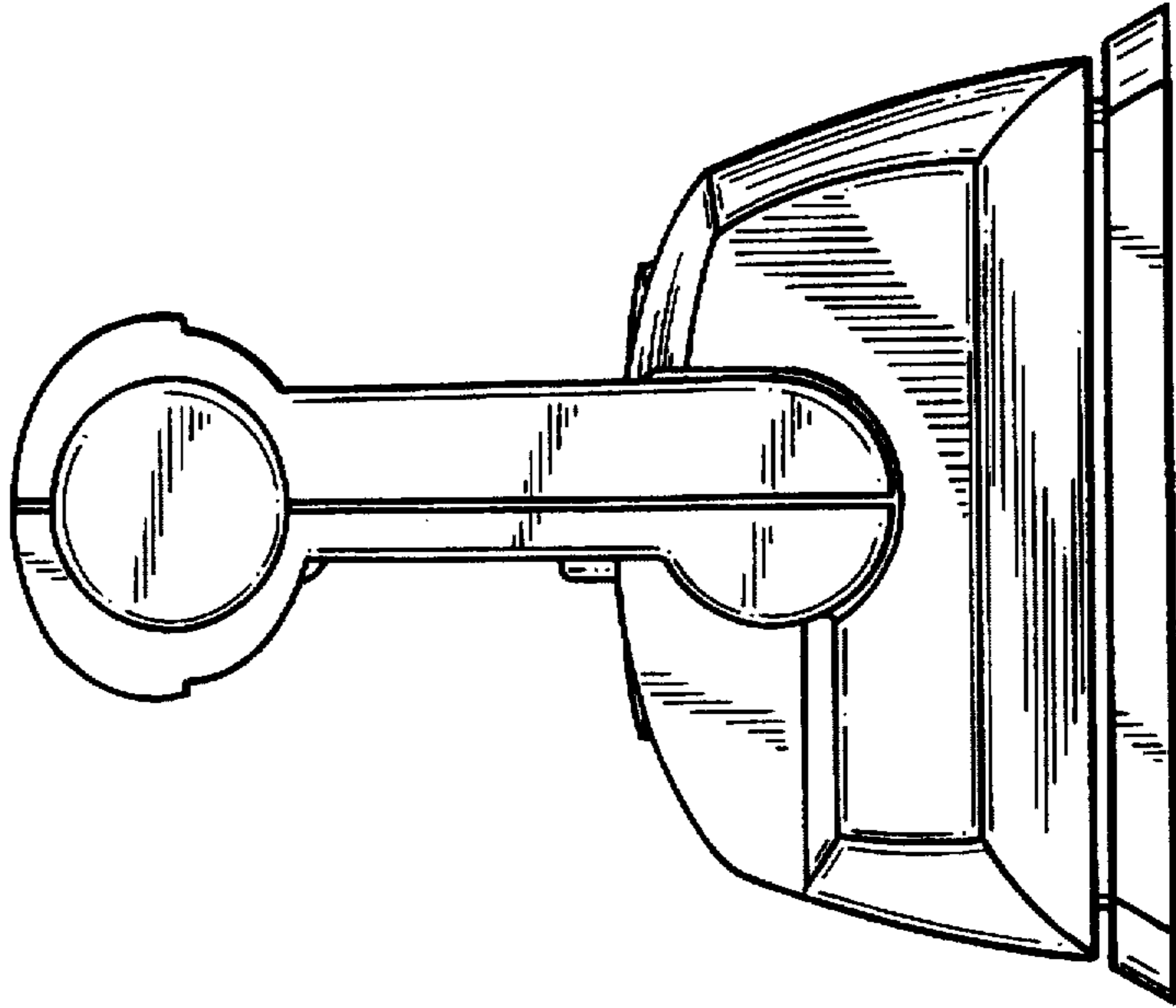

FIG. 7

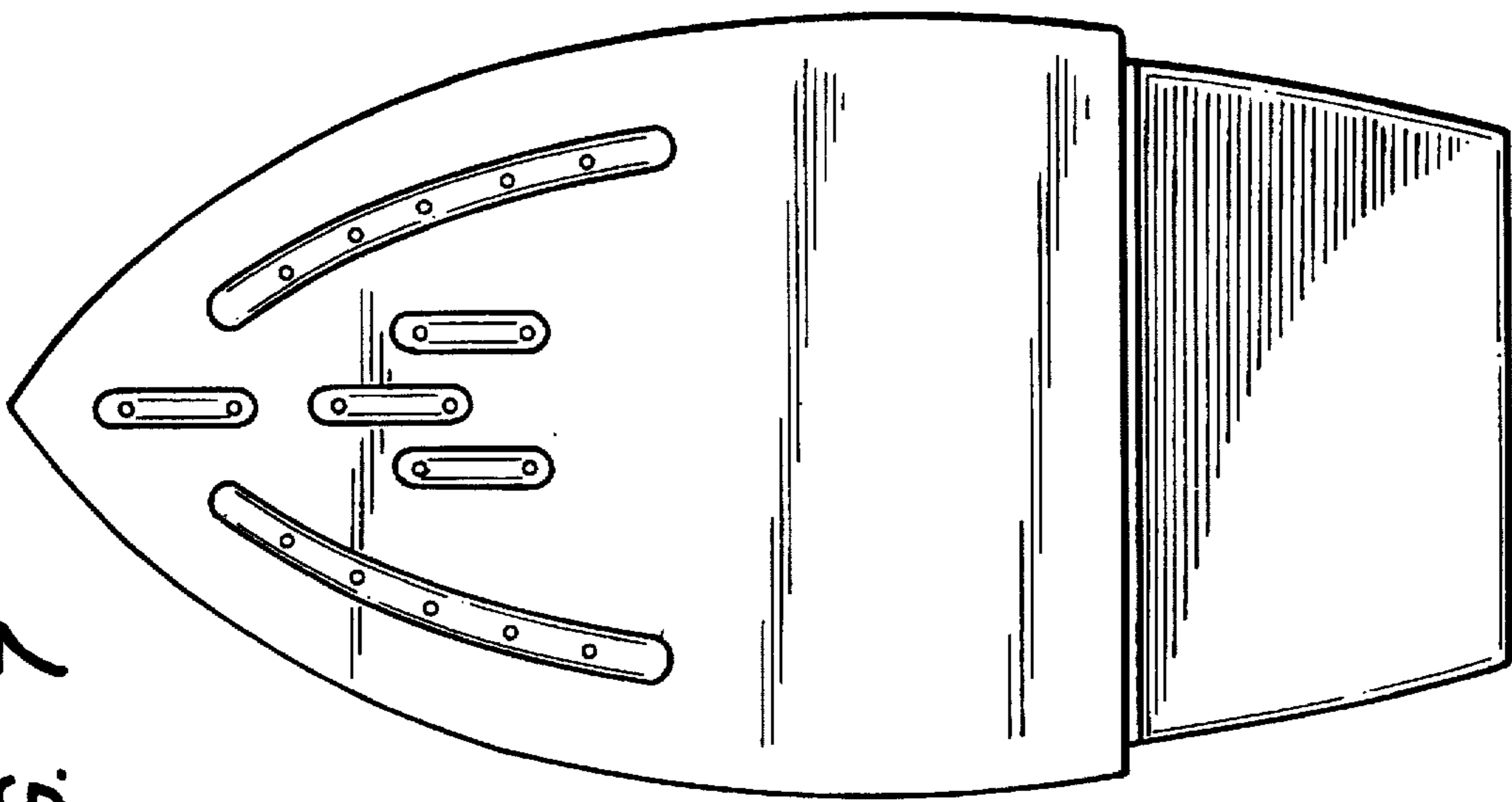

FIG. 8

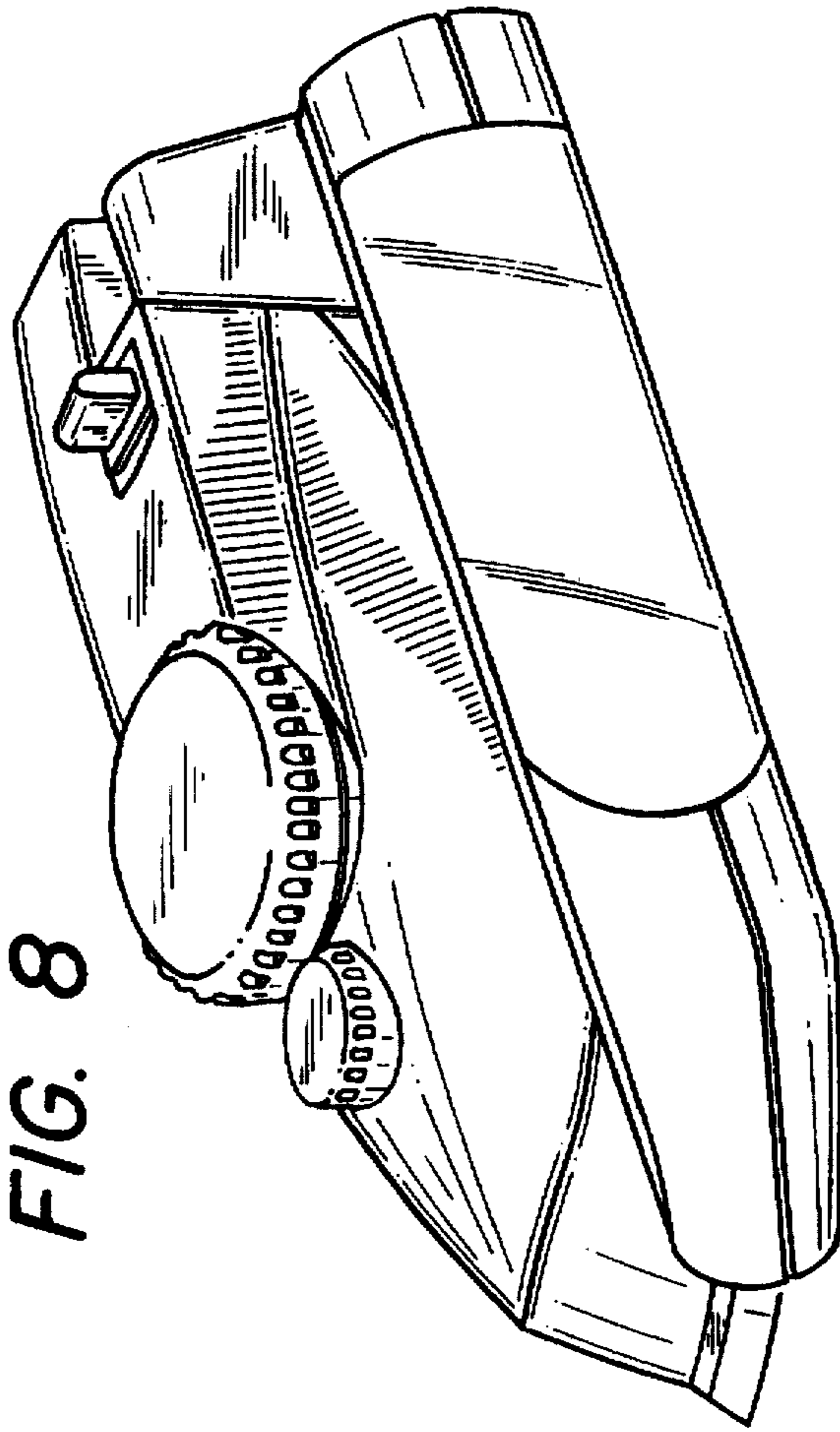

FIG. 9

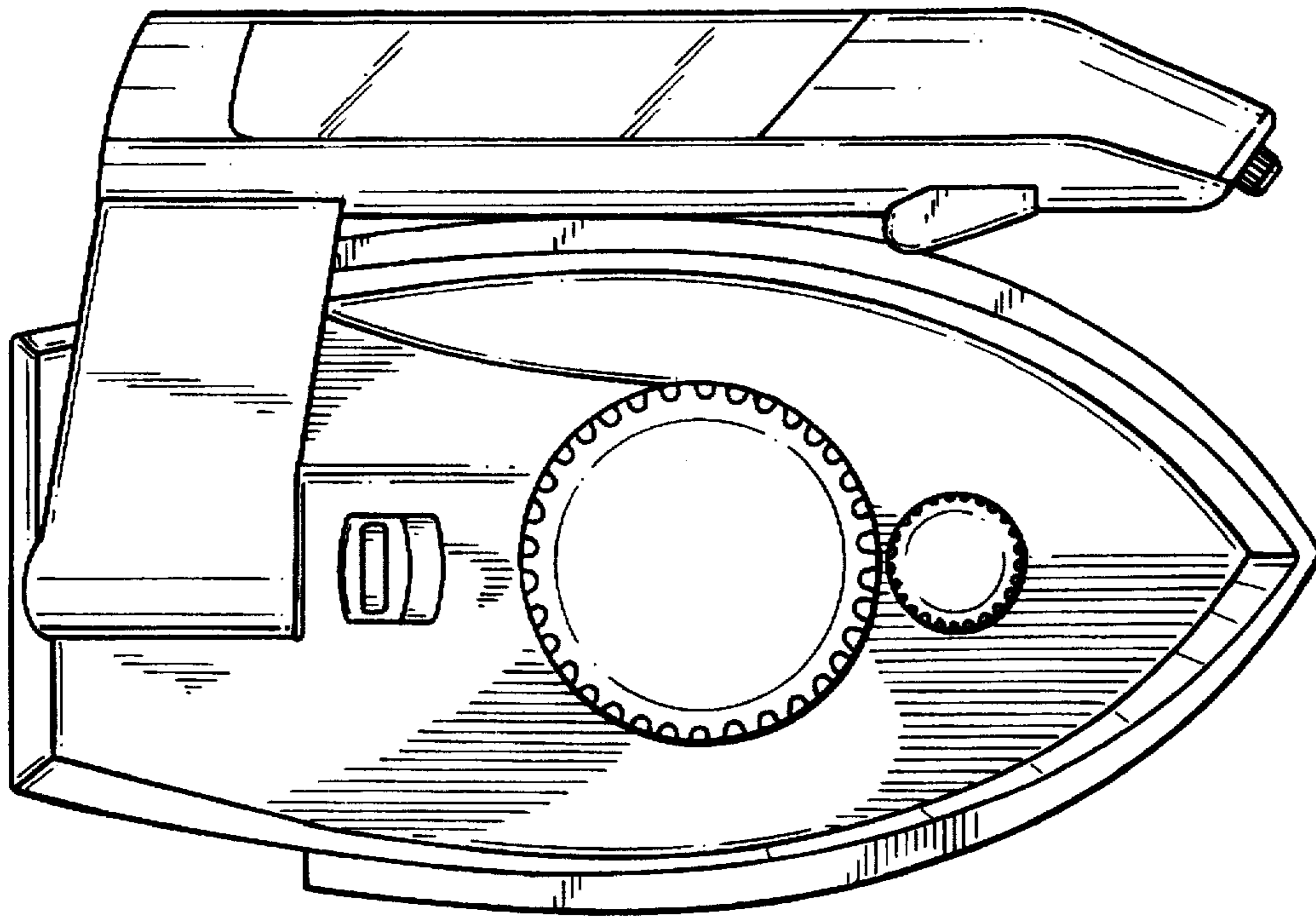

FIG. 10

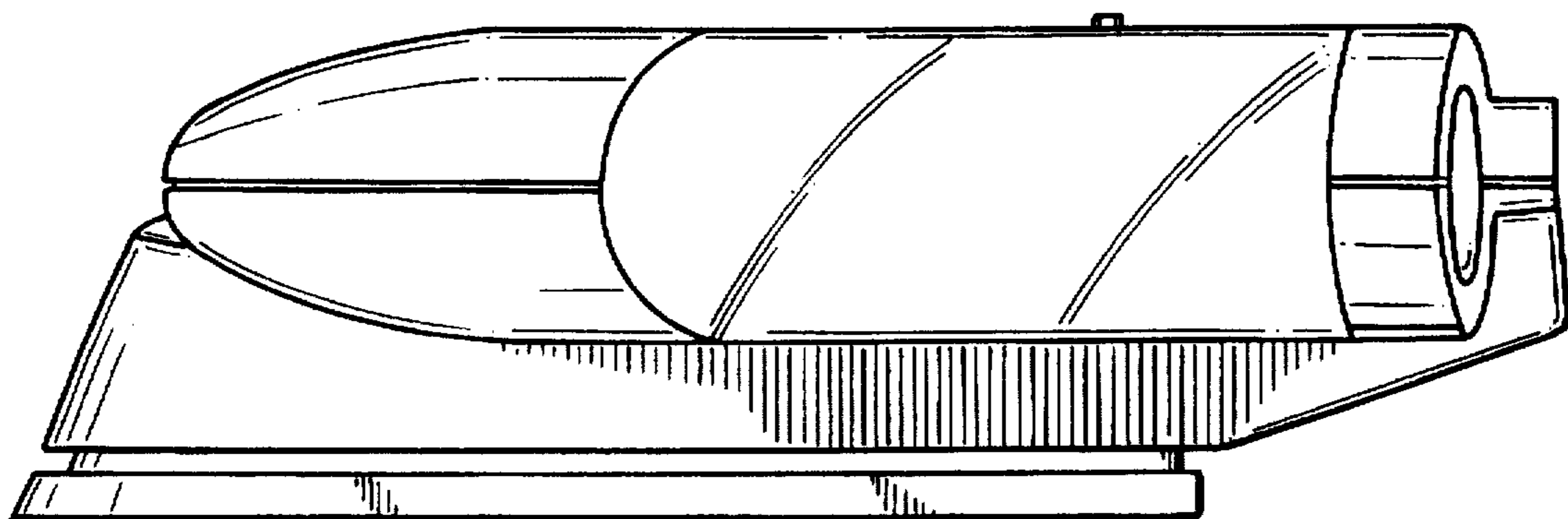

FIG. 11

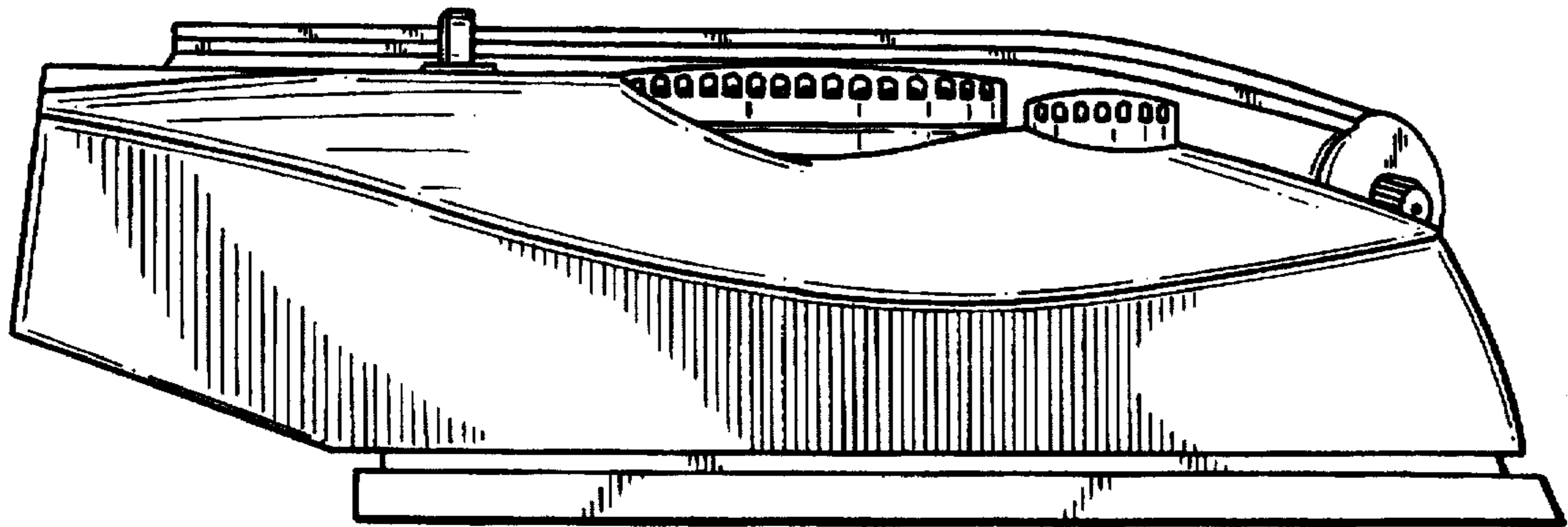

FIG. 12

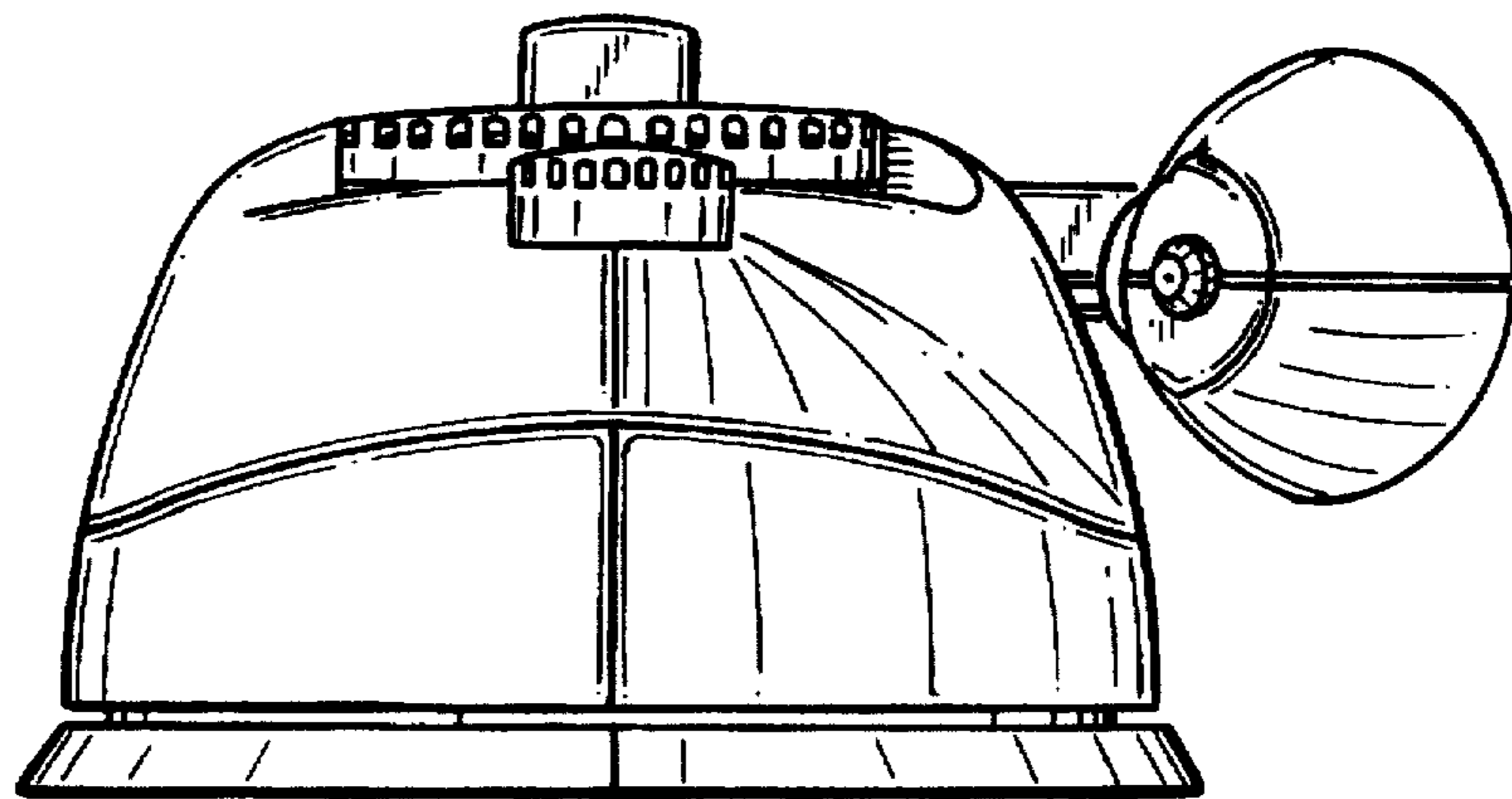

FIG. 13

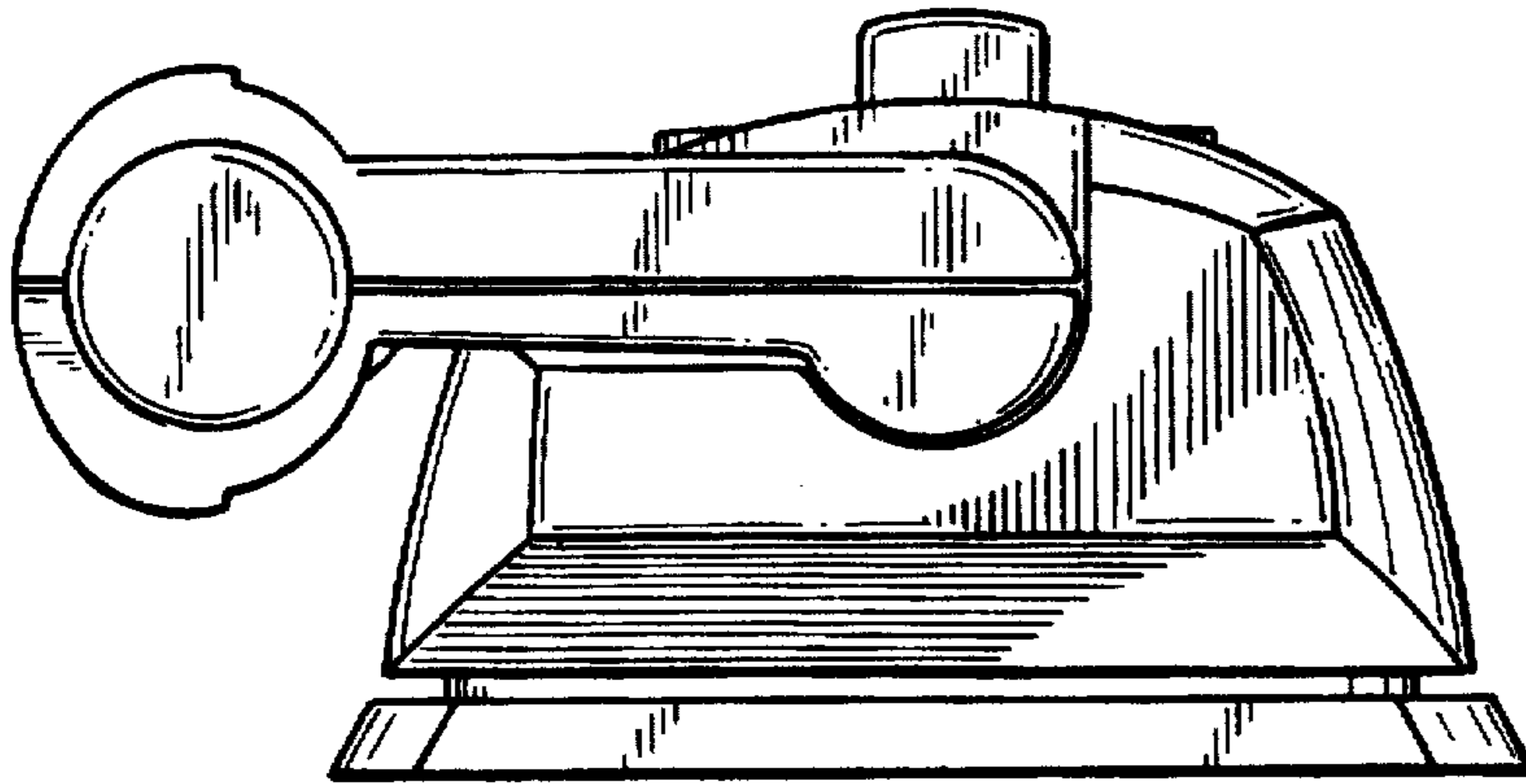

FIG. 14

