



US00D389944S

United States Patent [19]
Hutton

[11] **Patent Number: Des. 389,944**
[45] **Date of Patent: **Jan. 27, 1998**

[54] **LAMP BODY**

[75] **Inventor: John Hutton, New York, N.Y.**
[73] **Assignee: Donghia Furniture Co., Ltd., New York, N.Y.**
[**] **Term: 14 Years**

[21] **Appl. No.: 66,853**
[22] **Filed: Mar. 13, 1997**

[51] **LOC (6) Cl. 26-05**
[52] **U.S. Cl. D26/110; D6/495; D26/9; D26/20; D26/153**
[58] **Field of Search D26/93, 102-112, D26/153; 362/410-414; D6/495; D25/126**

[56] **References Cited**

U.S. PATENT DOCUMENTS

D. 82,481 11/1930 Collins D26/153
1,605,778 11/1926 Riley 362/412

OTHER PUBLICATIONS

Acme Lighting and Accessories catalog, p. 7, table lamp, center Dec. 1995.
Phil-Mar lighting catalog, p. 7, table lamp #1596, 1960.
Primary Examiner—Susan J. Lucas
Attorney, Agent, or Firm—Heslin & Rothenberg, P.C.

[57] **CLAIM**

The ornamental design for the lamp body, as shown and described.

DESCRIPTION

FIG. 1 is an elevational view of the lamp body comprising my new design;
FIG. 2 is a top plan view thereof;
FIG. 3 is a bottom plan view thereof; and,
FIG. 4 is a perspective view thereof.
The broken lines are shown for environmental purposes only and form no part of the claimed design.

1 Claim, 3 Drawing Sheets

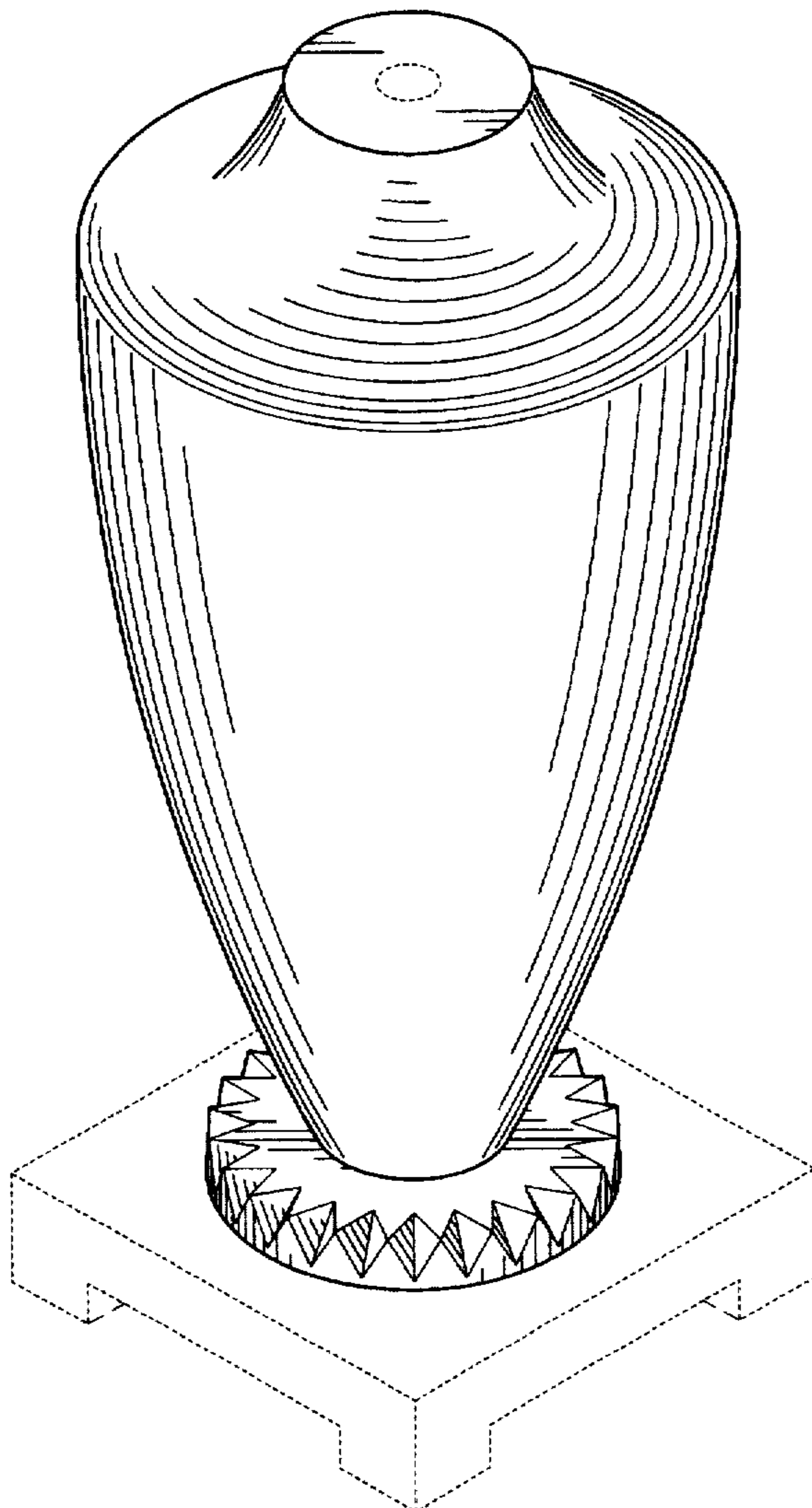

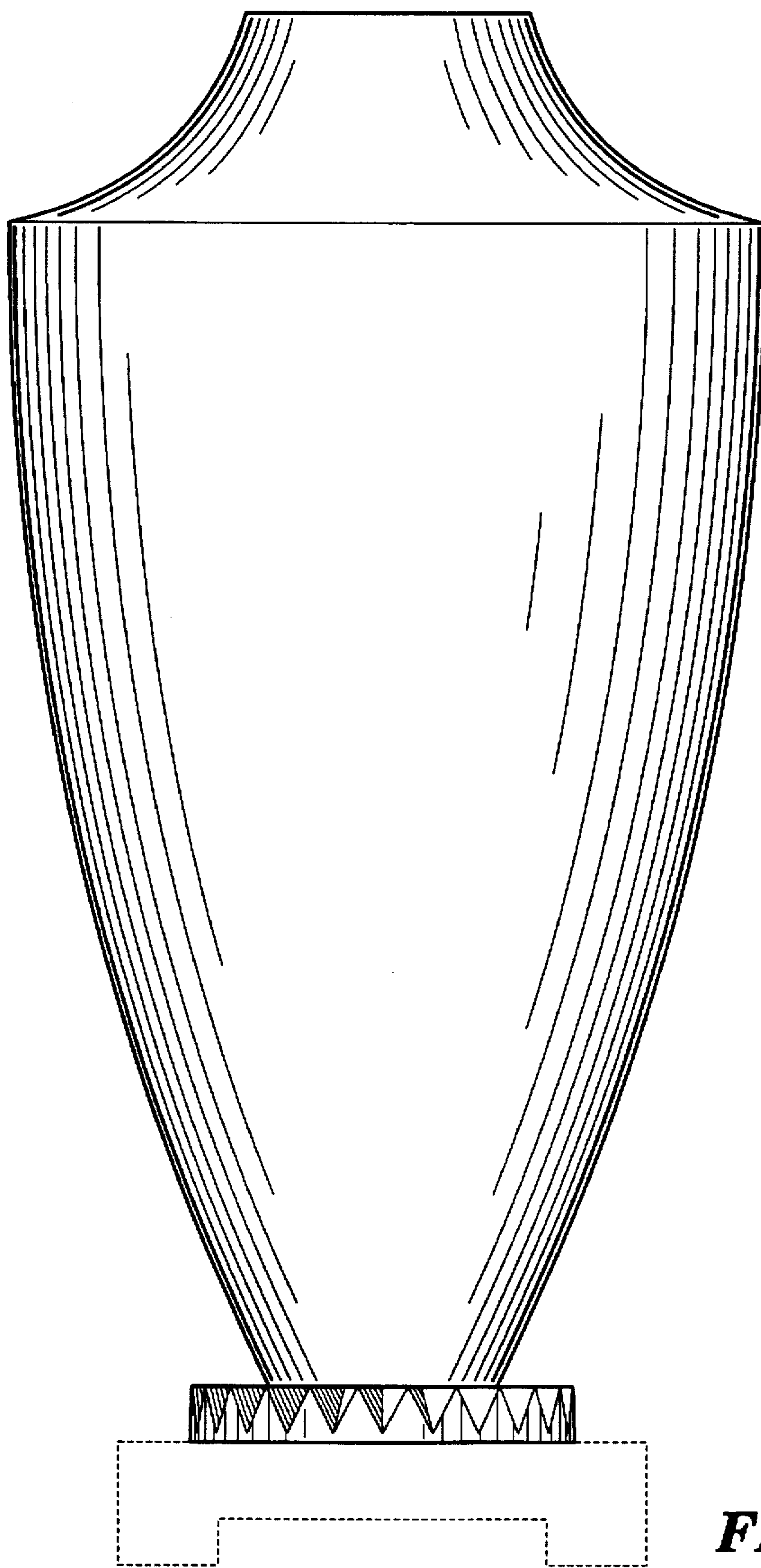

FIG. 1

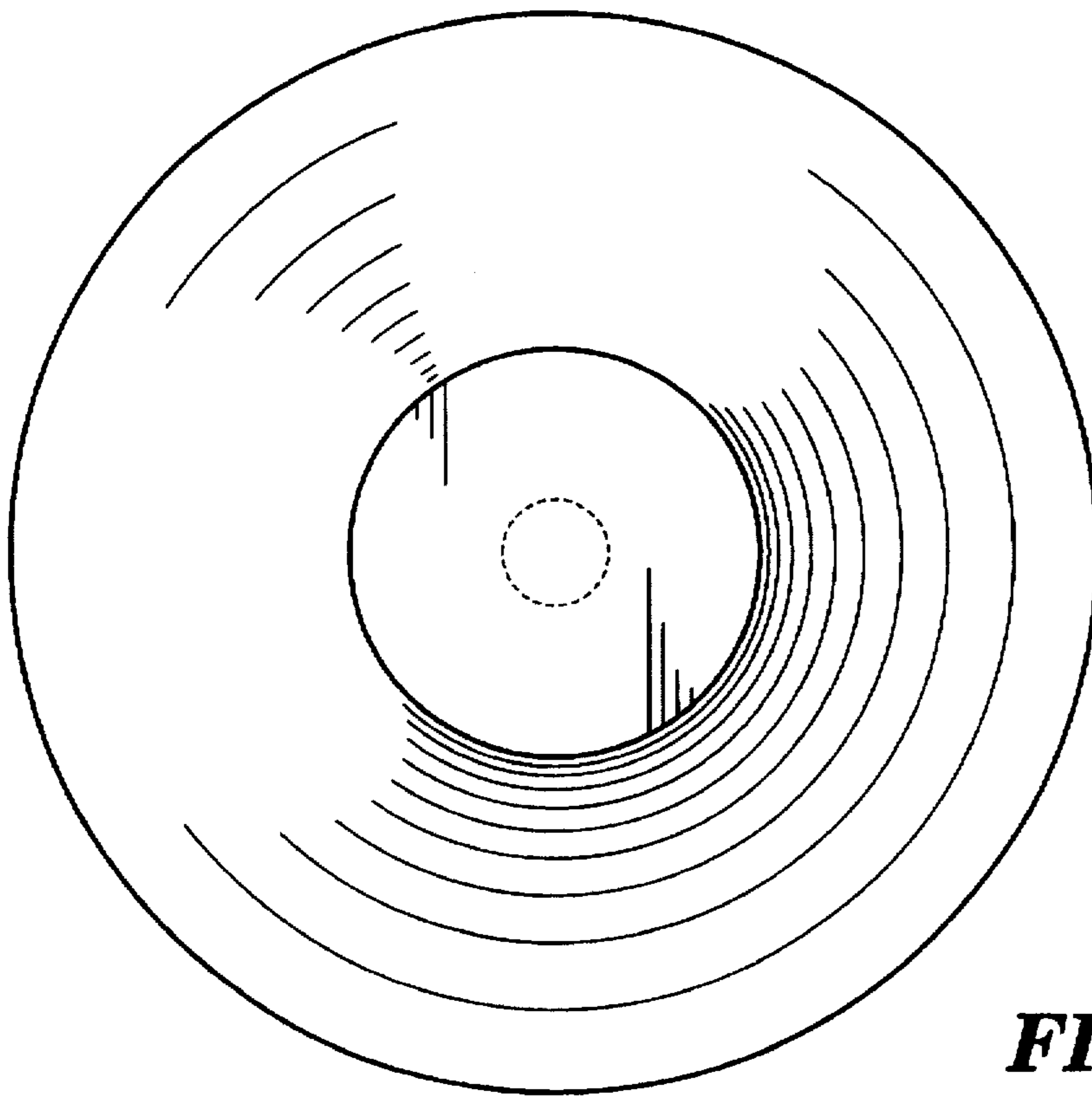

FIG. 2

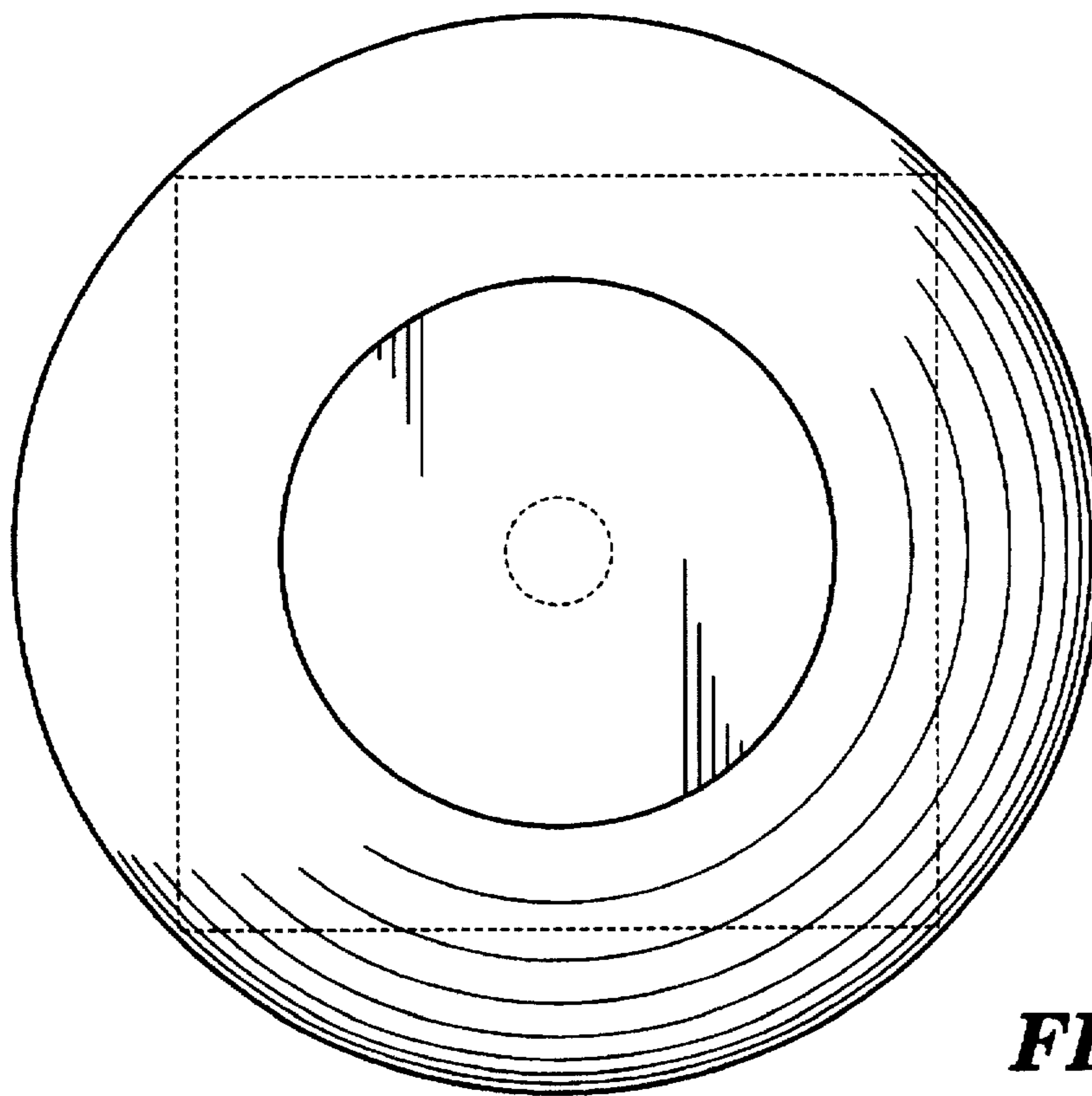

FIG. 3

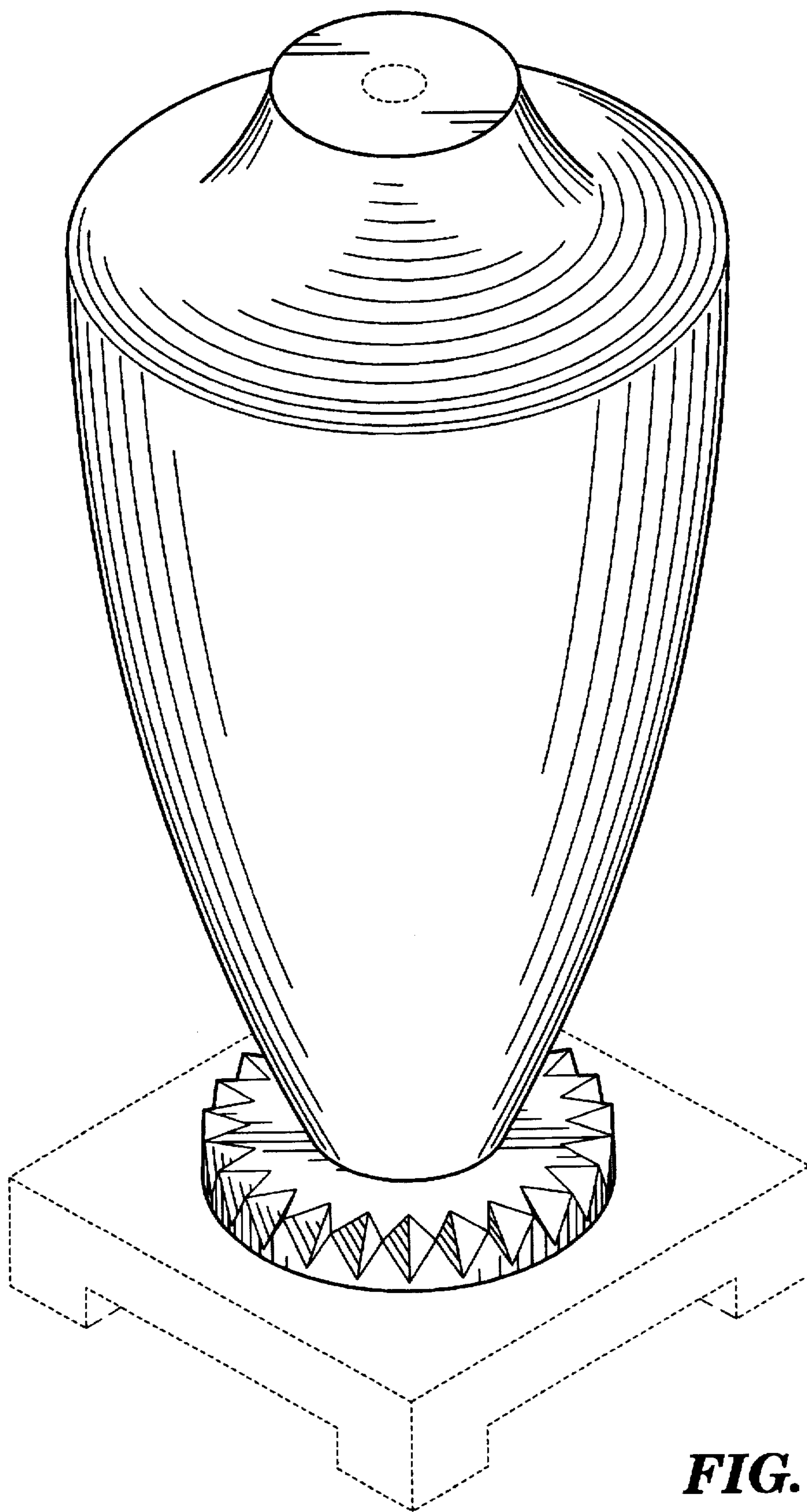

FIG. 4