



US00D389784S

United States Patent [19] Ishikawa

[11] Patent Number: **Des. 389,784**
[45] Date of Patent: ****Jan. 27, 1998**

[54] **AUTOMOBILE BODY**

Primary Examiner—Melody N. Brown

[76] Inventor: **Gou Ishikawa**, 985-1432 Oaza Kono Tado-cho, Kuwana-gun, Mie-ken, Japan

[57] **CLAIM**

[**] Term: **14 Years**

The ornamental design for an automobile body, as shown and described.

[21] Appl. No.: **56,956**

DESCRIPTION

[22] Filed: **Jul. 12, 1996**

FIG. 1 is a front, left perspective view of an automobile body according to the present invention;

[51] **LOC (6) Cl.** **12-08**

FIG. 2 is a rear, left perspective view;

[52] **U.S. Cl.** **D12/92**

FIG. 3 is a rear elevational view;

[58] **Field of Search** **D12/90-92; 296/185**

FIG. 4 is a front elevational view;

FIG. 5 is a top plan view thereof; and,

[56] **References Cited**

FIG. 6 is a left side elevational view, the right side is a mirror image.

U.S. PATENT DOCUMENTS

The broken line drawings of wheels in FIGS. 1-4 and 6 are for illustrative purposes only and form no part of the claimed design.

D. 298,521	11/1988	Ui et al.	D12/91
D. 338,431	8/1993	Abele	D12/91
D. 346,990	5/1994	Abbott et al.	D12/91
D. 357,648	4/1995	Osawa et al.	D12/91
D. 371,526	7/1996	Verduyn et al.	D12/86
D. 372,686	8/1996	Hattori et al.	D12/91

1 Claim, 5 Drawing Sheets

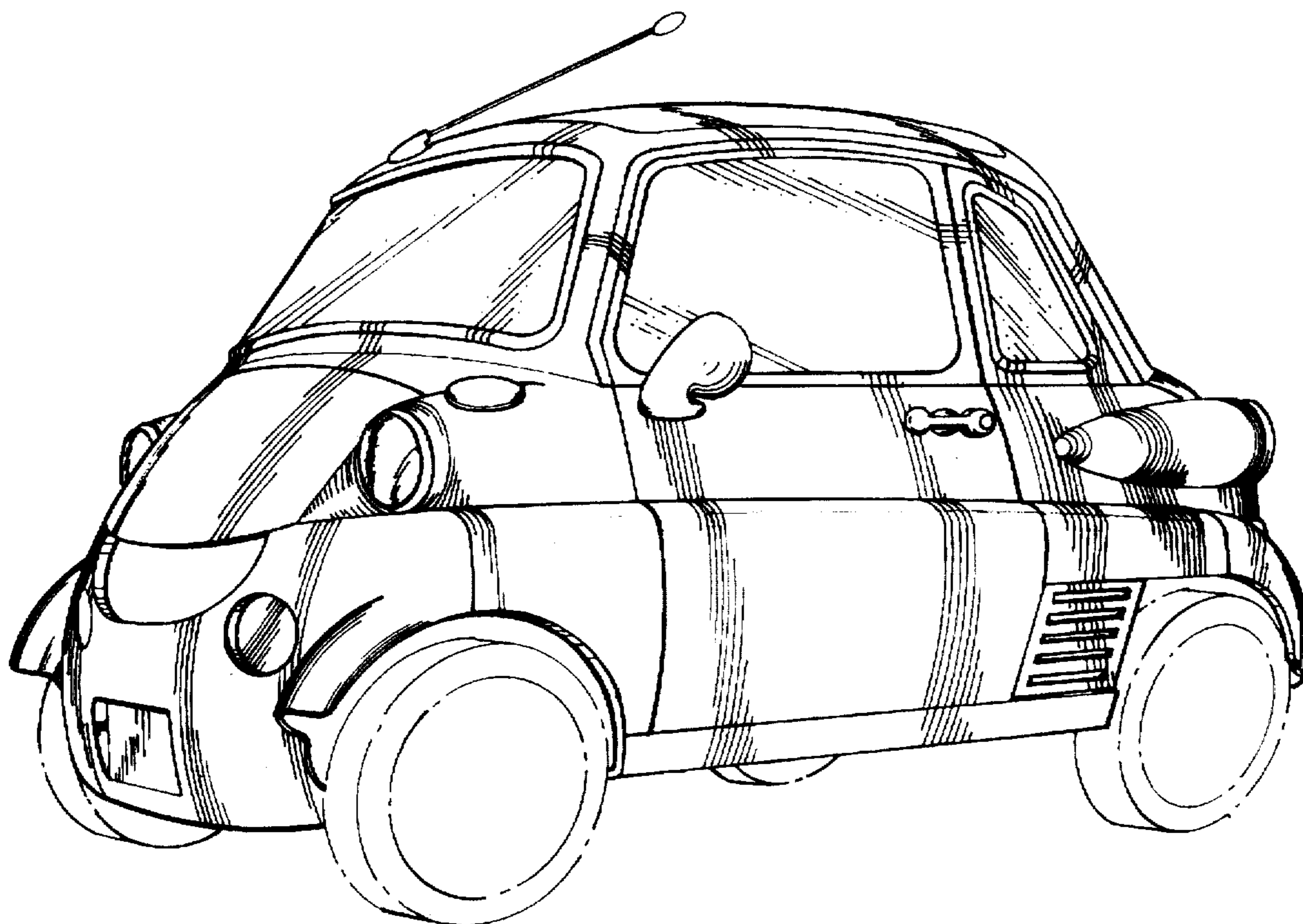

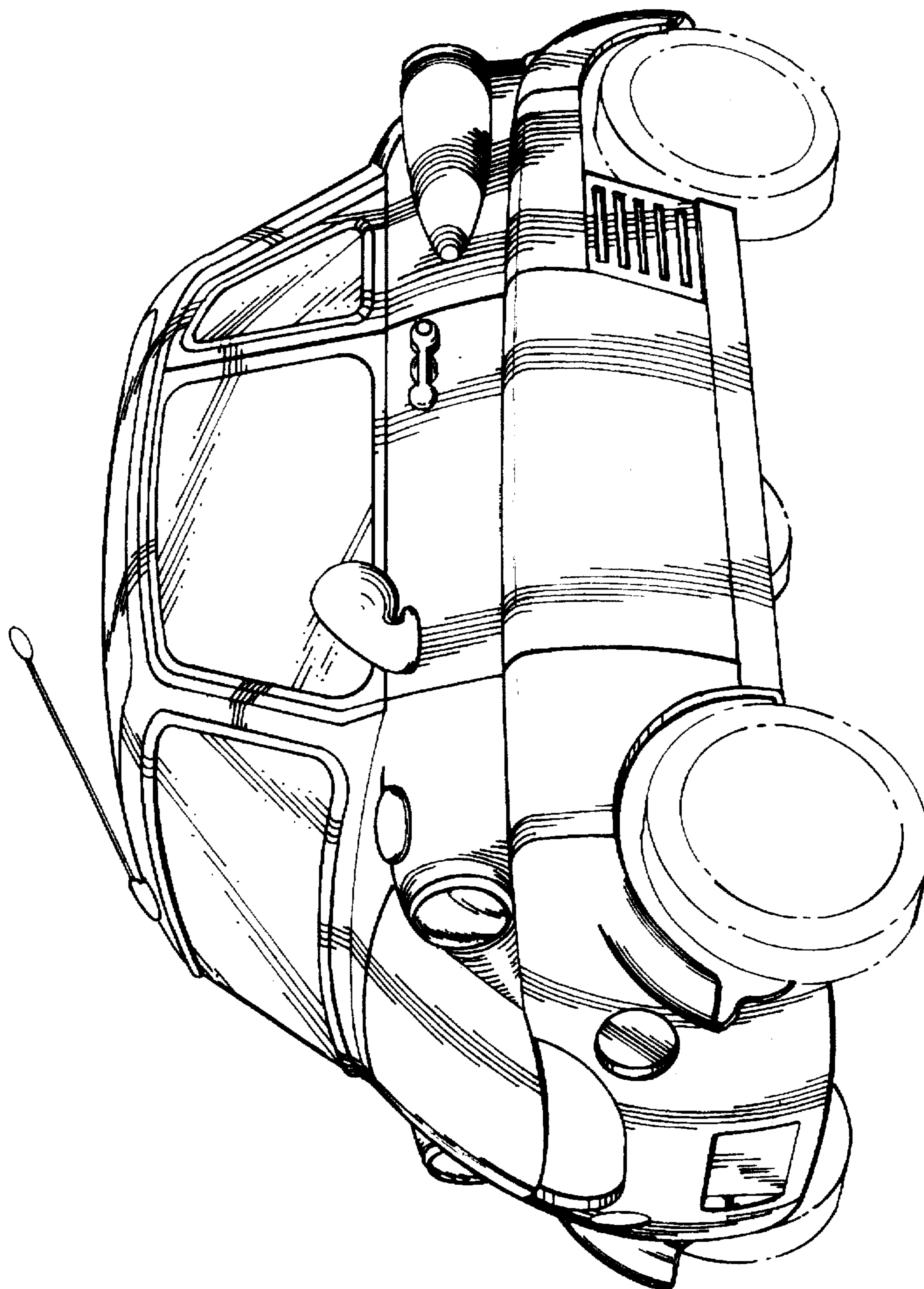

Fig-1

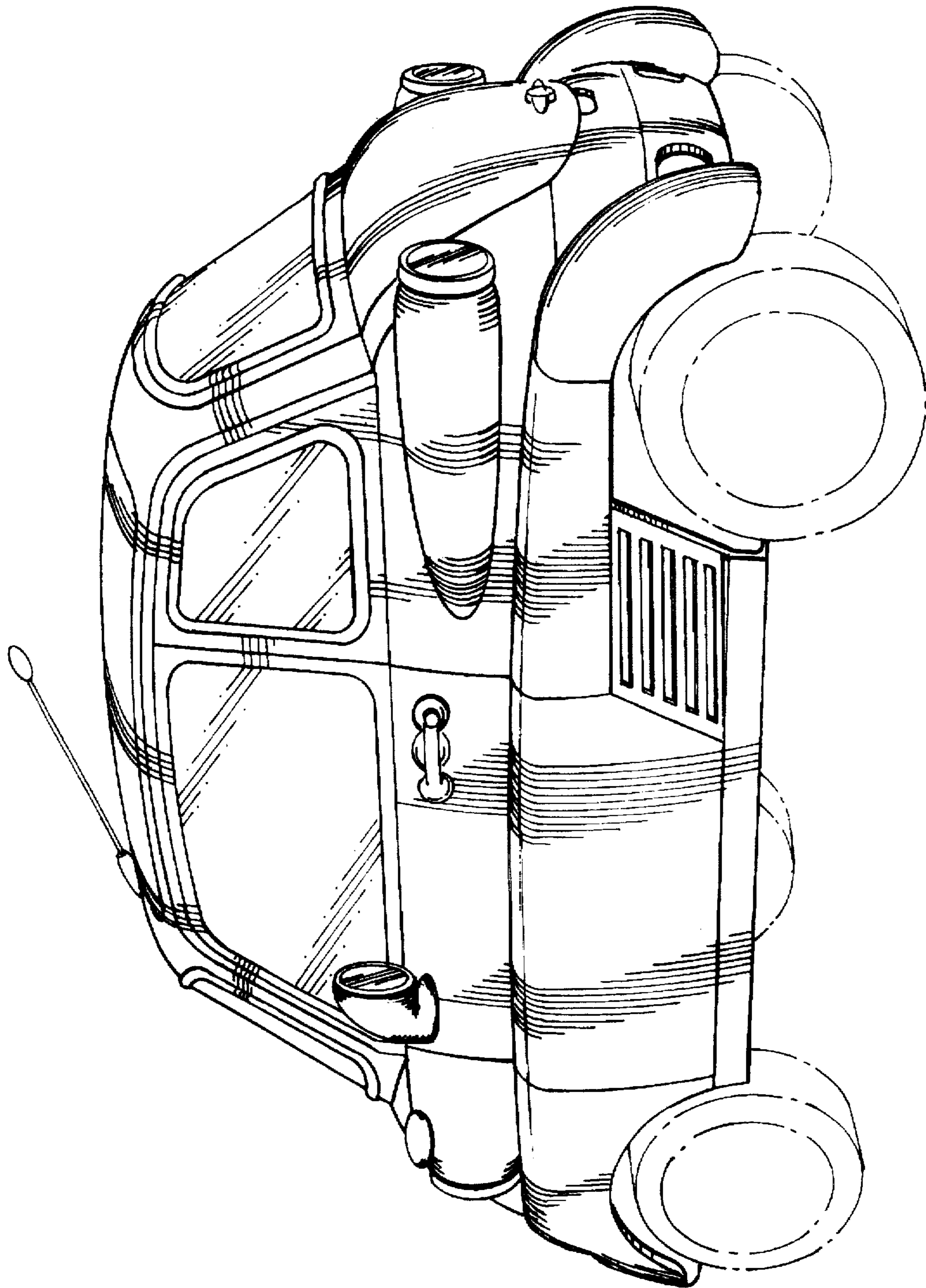

Fig-2

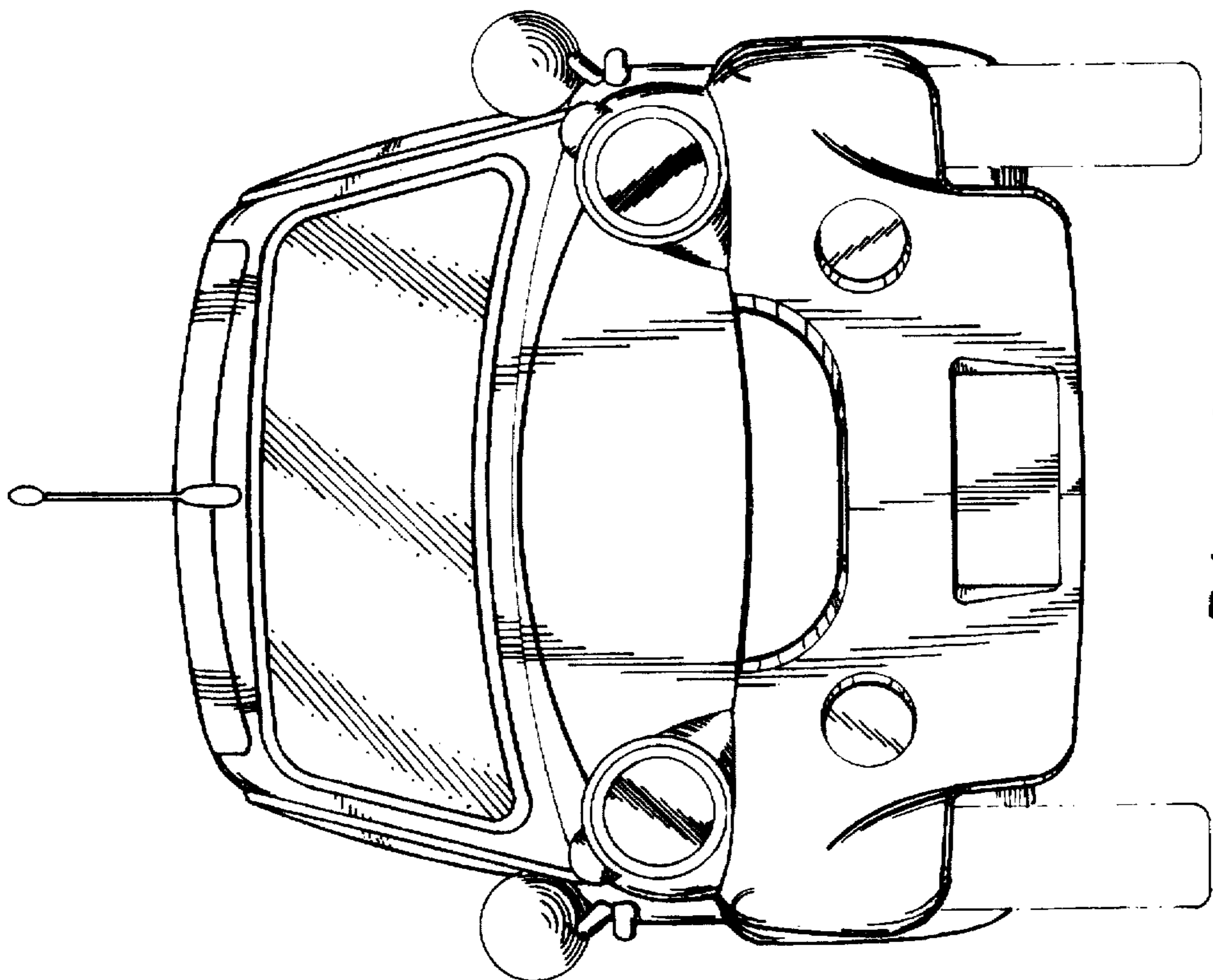

Fig-4

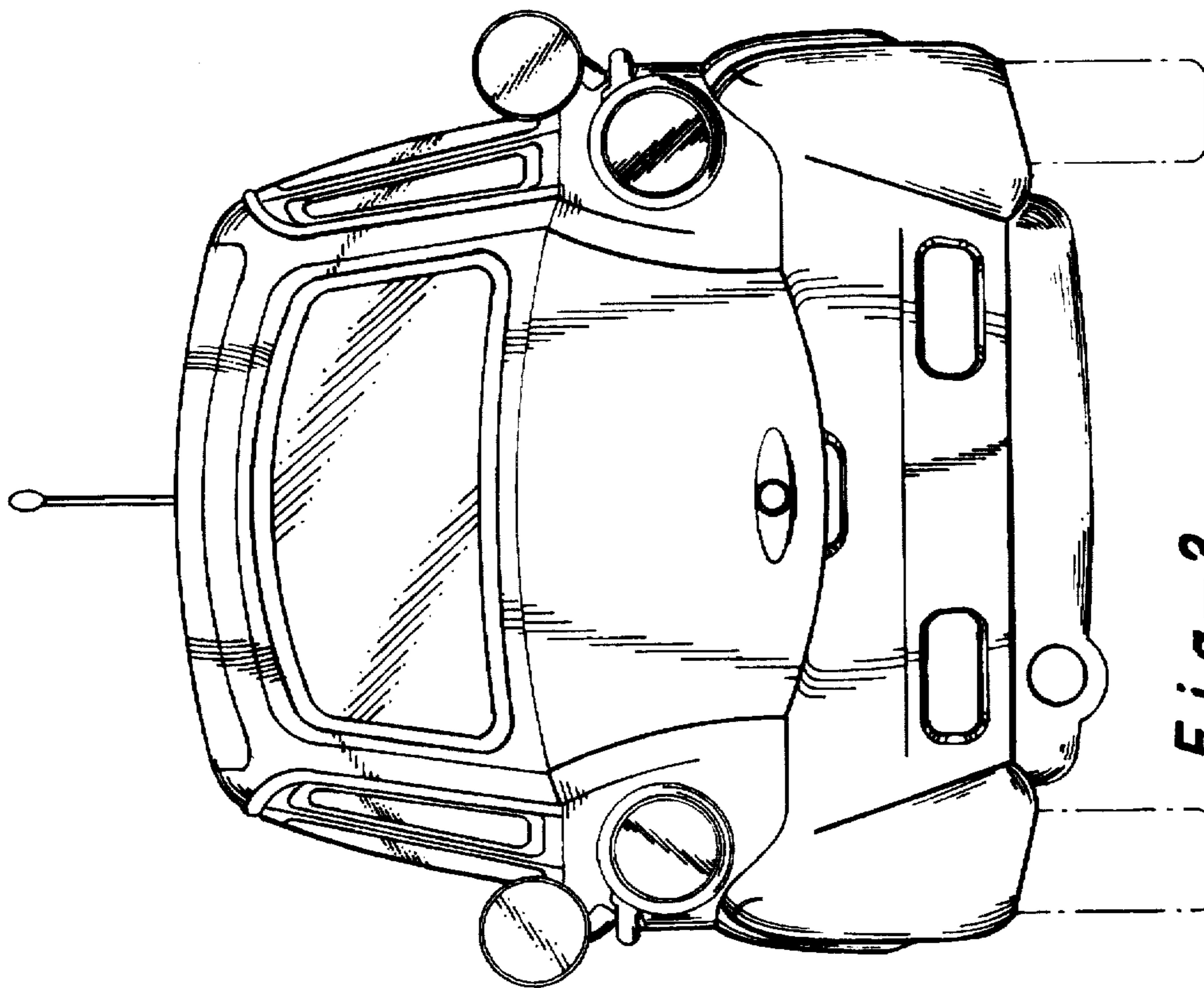

Fig-3

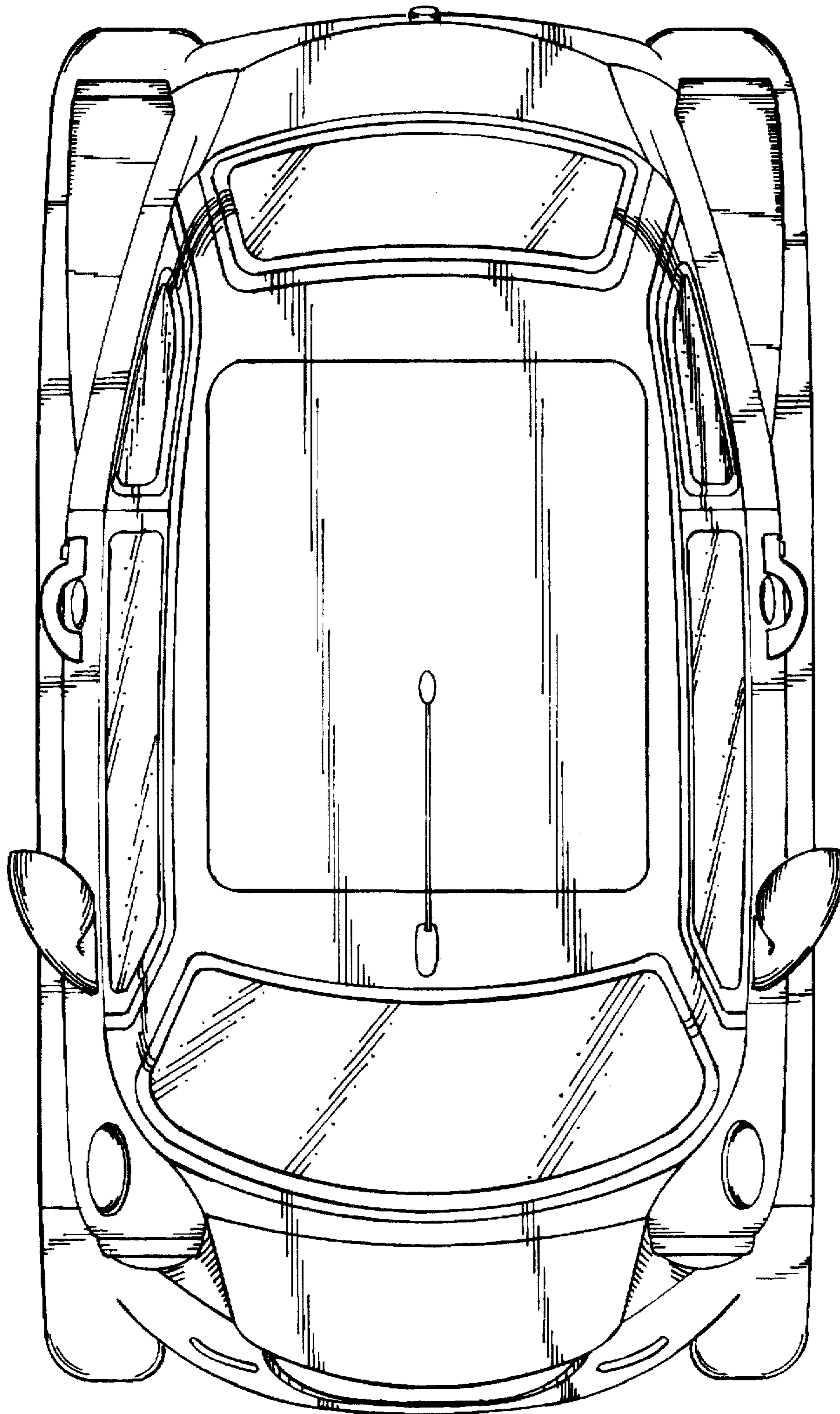

Fig-5

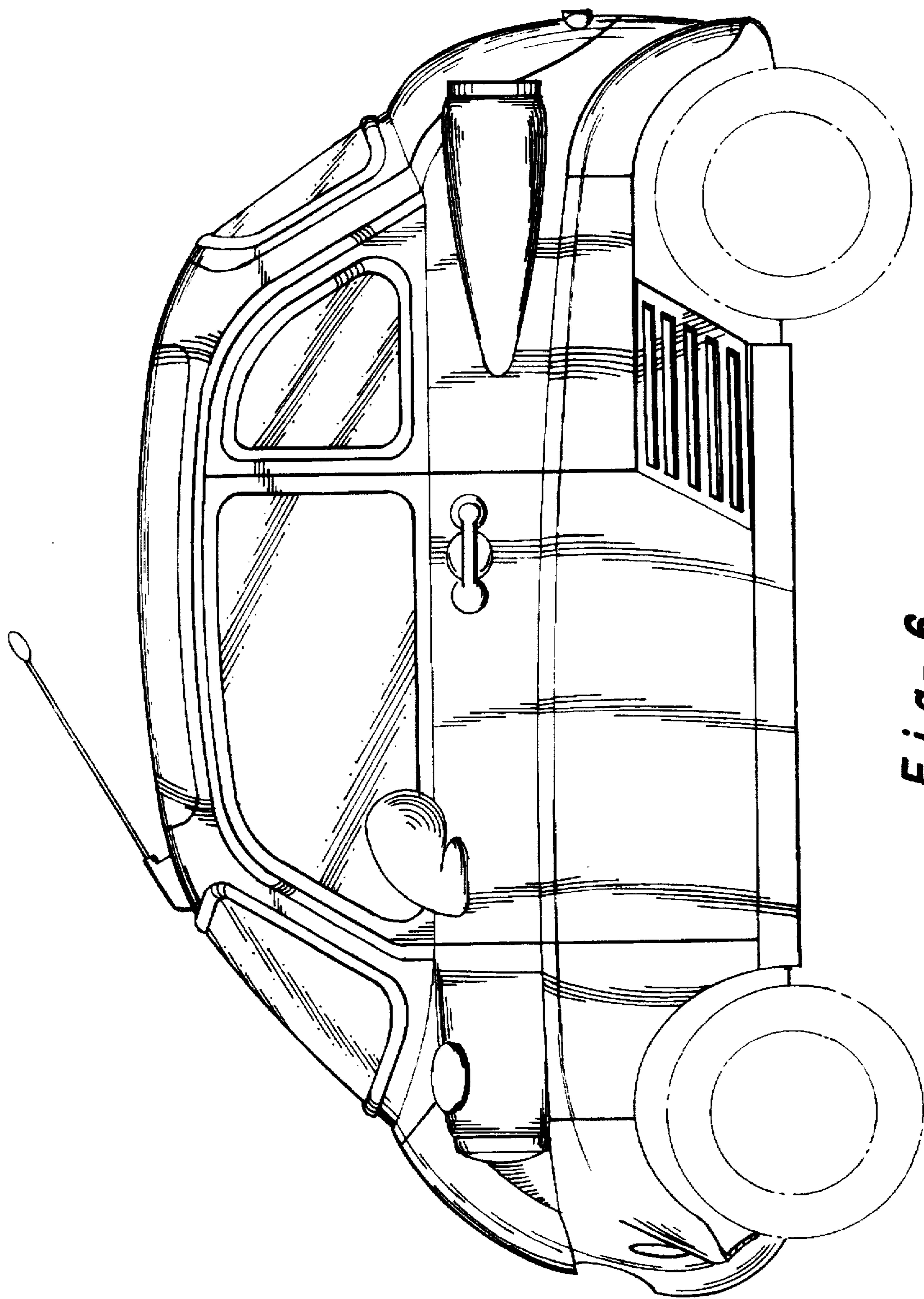

Fig-6