

FIG. 26 is a bottom, front and side perspective view thereof;
FIG. 27 is a side elevational view of a fifth embodiment of my new design, the opposite side being a mirror image;
FIG. 28 is a top plan view thereof;
FIG. 29 is a bottom plan view thereof;
FIG. 30 is a front elevational view thereof;
FIG. 31 is a side elevational view of a sixth embodiment of my new design, the opposite side being a mirror image;
FIG. 32 is a top plan view thereof;
FIG. 33 is a bottom plan view thereof;
FIG. 34 is a front elevational view thereof;
FIG. 35 is a side elevational view of a seventh embodiment of my new design;
FIG. 36 is a bottom plan view thereof;
FIG. 37 is a side elevational view thereof as seen from the opposite side of FIG. 35;
FIG. 38 is a front elevational view thereof;
FIG. 39 is a top, front and side perspective view thereof;
FIG. 40 is a rear elevational view thereof;
FIG. 41 is a top, rear and side perspective view thereof;
FIG. 42 is a top plan view thereof;
FIG. 43 is a bottom, front and side perspective view thereof;
FIG. 44 is a side elevational view of an eighth embodiment of my new design, the opposite side being a mirror image;
FIG. 45 is a top plan view thereof;
FIG. 46 is a bottom plan view thereof;
FIG. 47 is a front elevational view thereof;
FIG. 48 is a side elevational view of a ninth embodiment of my new design, the opposite side being a mirror image;
FIG. 49 is a top plan view thereof;
FIG. 50 is a bottom plan view thereof;
FIG. 51 is a front elevational view thereof;
FIG. 52 is a side elevational view of a tenth embodiment of my new design, the opposite side being a mirror image;
FIG. 53 is a top plan view thereof;
FIG. 54 is a bottom plan view thereof;
FIG. 55 is a front elevational view thereof;
FIG. 56 is a side elevational view of an eleventh embodiment of my new design, the opposite side being a mirror image;

FIG. 57 is a top plan view thereof, the bottom side being a mirror image;
FIG. 58 is a bottom plan view thereof;
FIG. 59 is a front elevational view thereof;
FIG. 60 is a side elevational view of a twelfth embodiment of my new design, the opposite side being a mirror image;
FIG. 61 is a top plan view thereof;
FIG. 62 is a bottom plan view thereof;
FIG. 63 is a front elevational view thereof;
FIG. 64 is a side elevational view of a thirteenth embodiment of my new design, the opposite side being a mirror image;
FIG. 65 is a top plan view thereof, the bottom side being a mirror image;
FIG. 66 is a bottom plan view thereof;
FIG. 67 is a front elevational view thereof;
FIG. 68 is a side elevational view of an fourteenth embodiment of my new design, the opposite side being a mirror image;
FIG. 69 is a top plan view thereof;
FIG. 70 is a bottom plan view thereof;
FIG. 71 is a front elevational view thereof;
FIG. 72 is a side elevational view of a fifteenth embodiment of my new design, the opposite side being a mirror image;
FIG. 73 is a top plan view thereof;
FIG. 74 is a bottom plan view thereof;
FIG. 75 is a front elevational view thereof;
FIG. 76 is a side elevational view of a sixteenth embodiment of my new design, the opposite side being a mirror image;
FIG. 77 is a top plan view thereof;
FIG. 78 is a bottom plan view thereof;
FIG. 79 is a front elevational view thereof;
FIG. 80 is a side elevational view of a seventeenth embodiment of my new design, the opposite side being a mirror image;
FIG. 81 is a top plan view thereof;
FIG. 82 is a bottom plan view thereof; and,
FIG. 83 is a front elevational view thereof.

1 Claim, 17 Drawing Sheets

FIG. 3

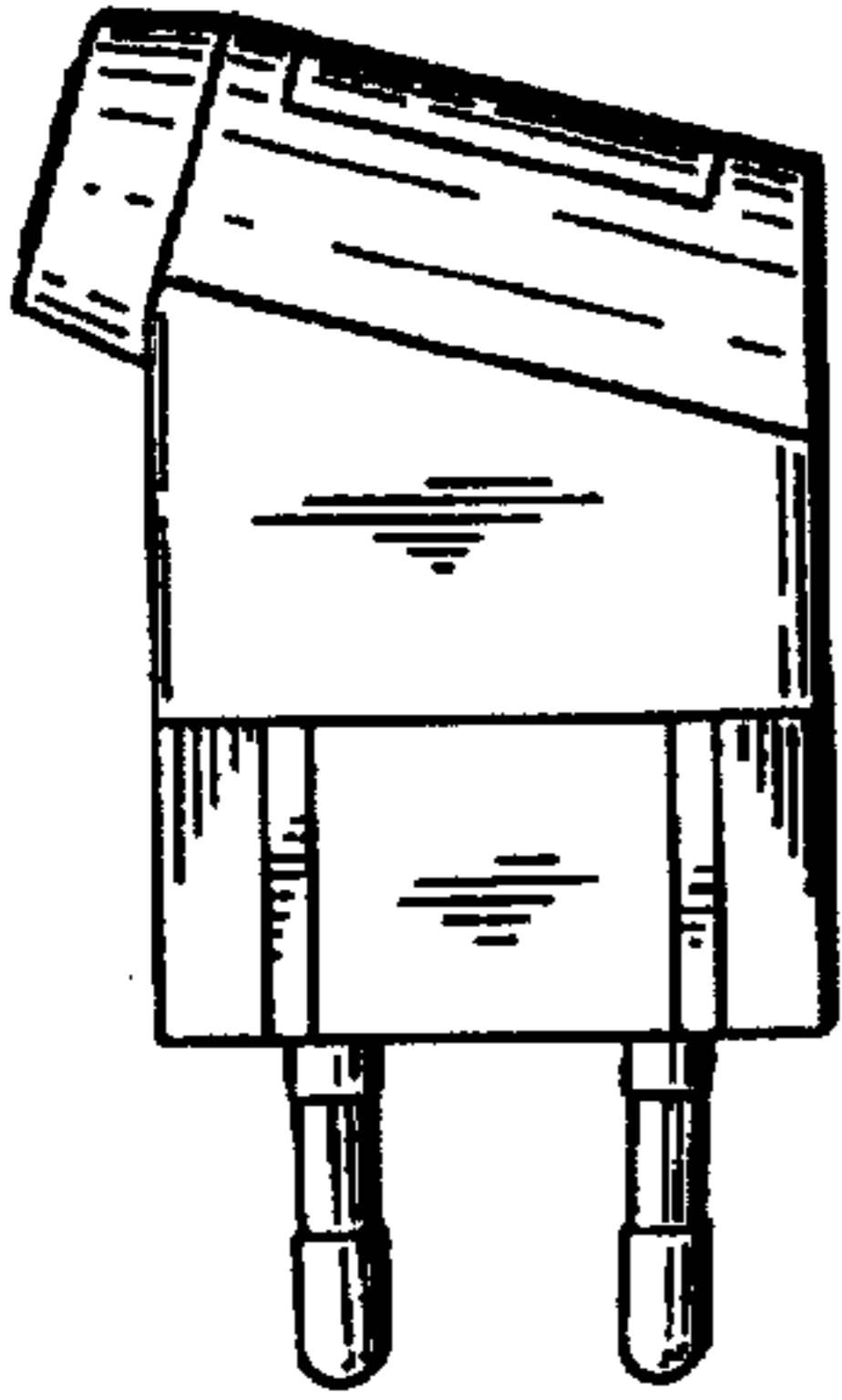

FIG. 6

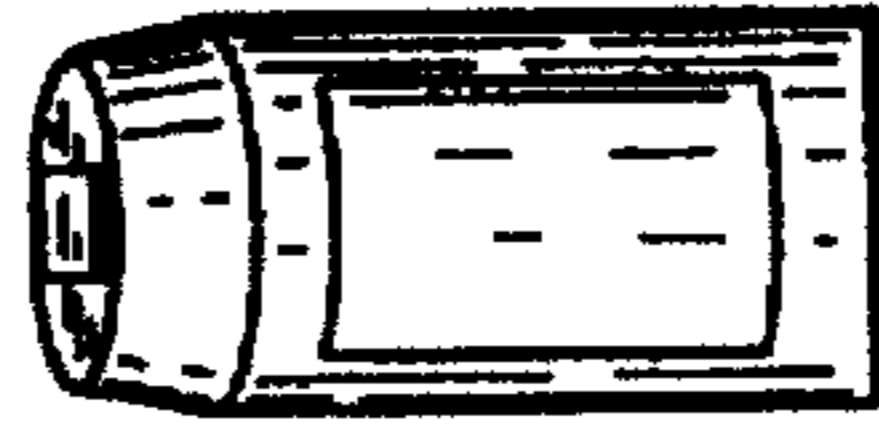

FIG. 9

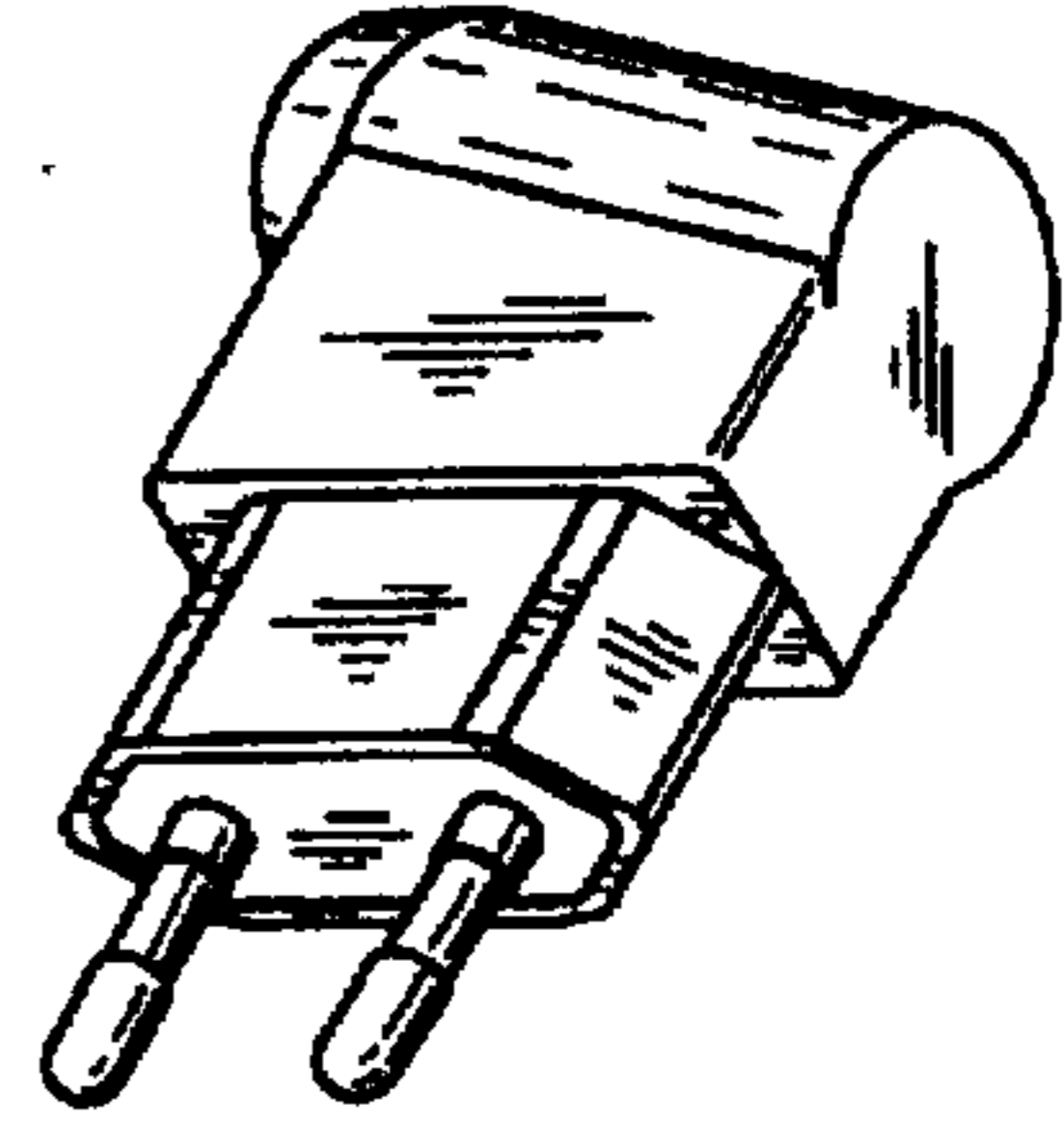

FIG. 2

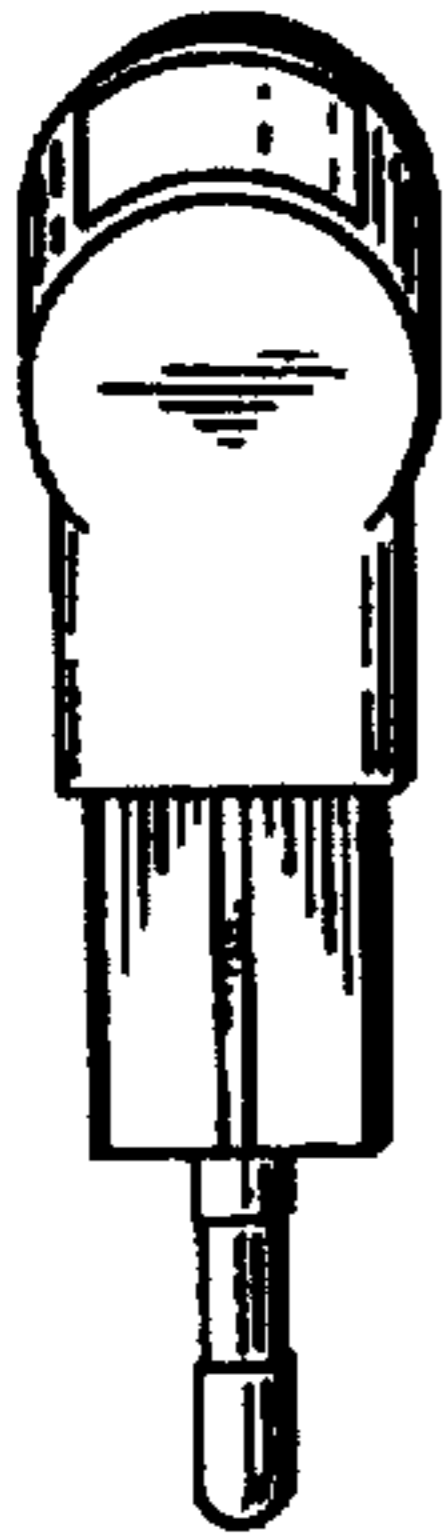

FIG. 5

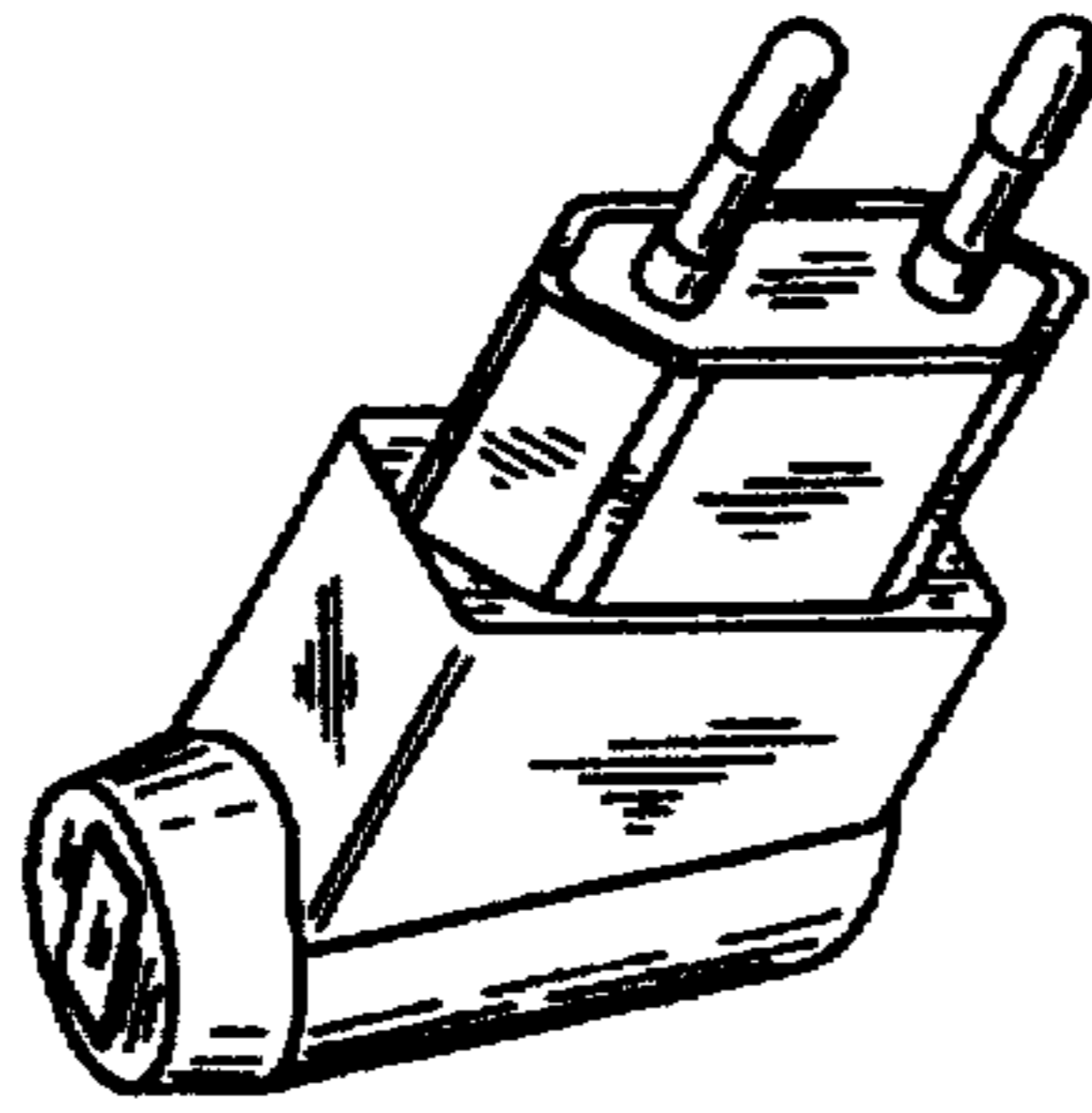

FIG. 8



FIG. 1

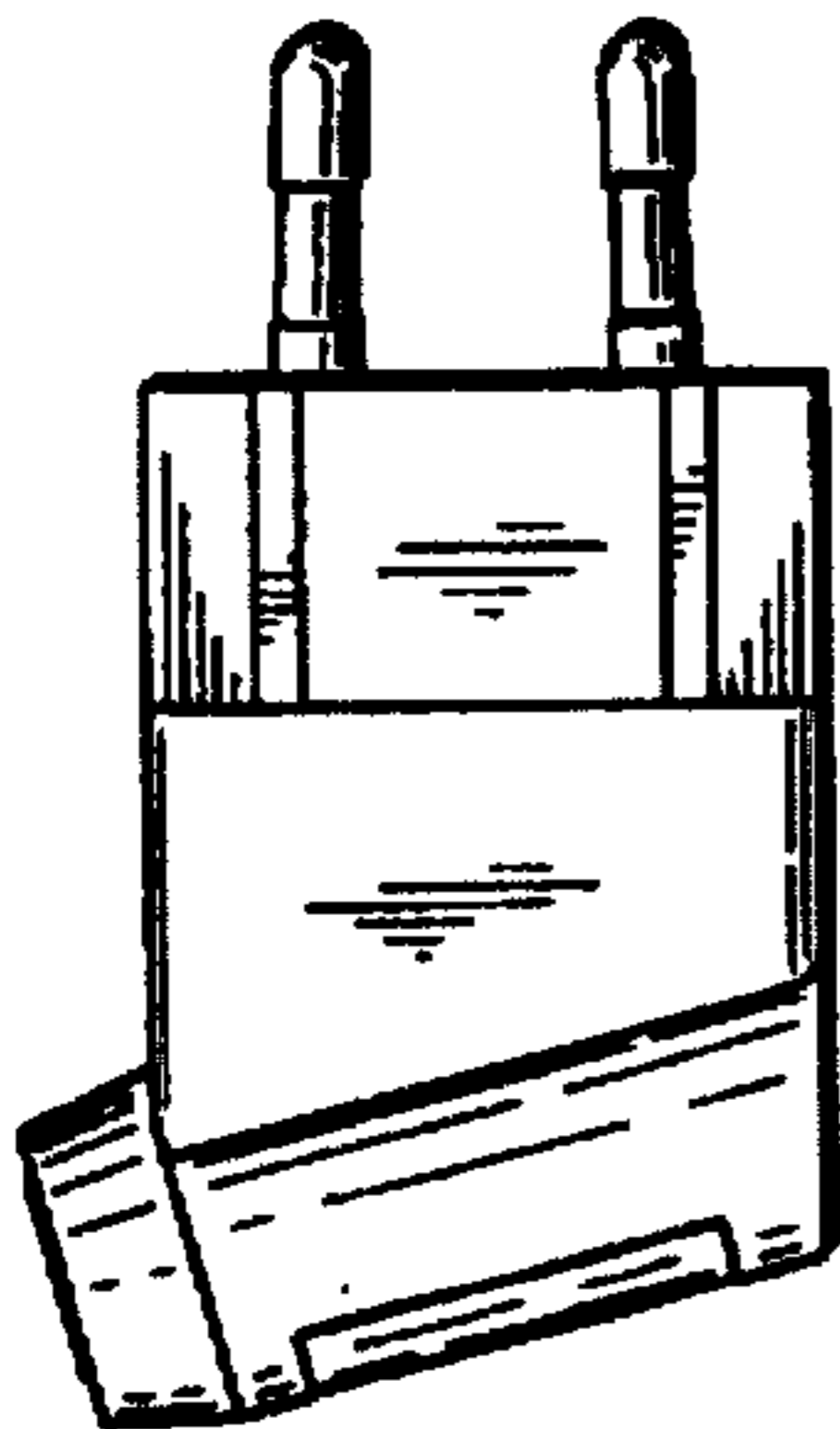

FIG. 4



FIG. 7

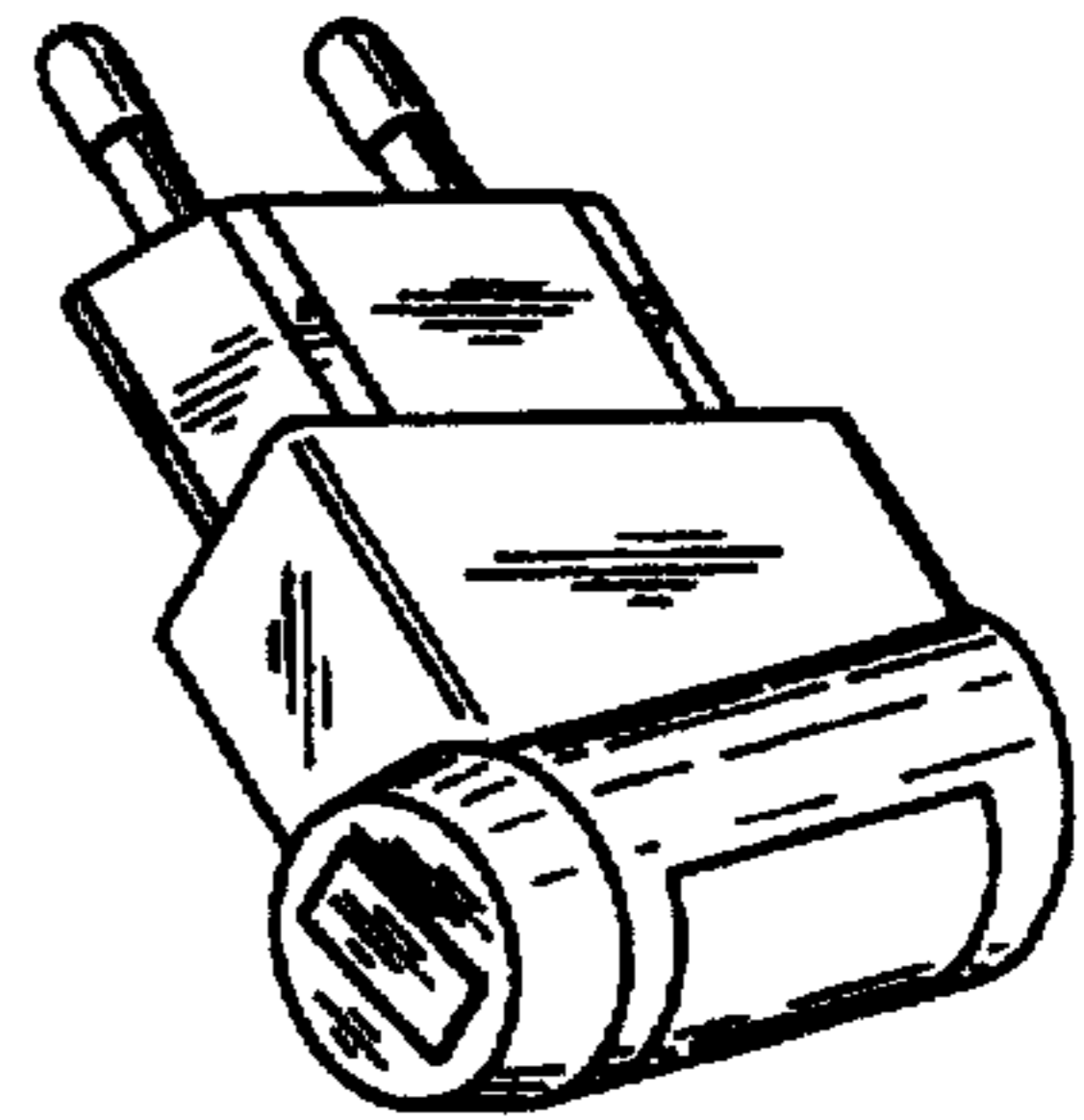

FIG. 10

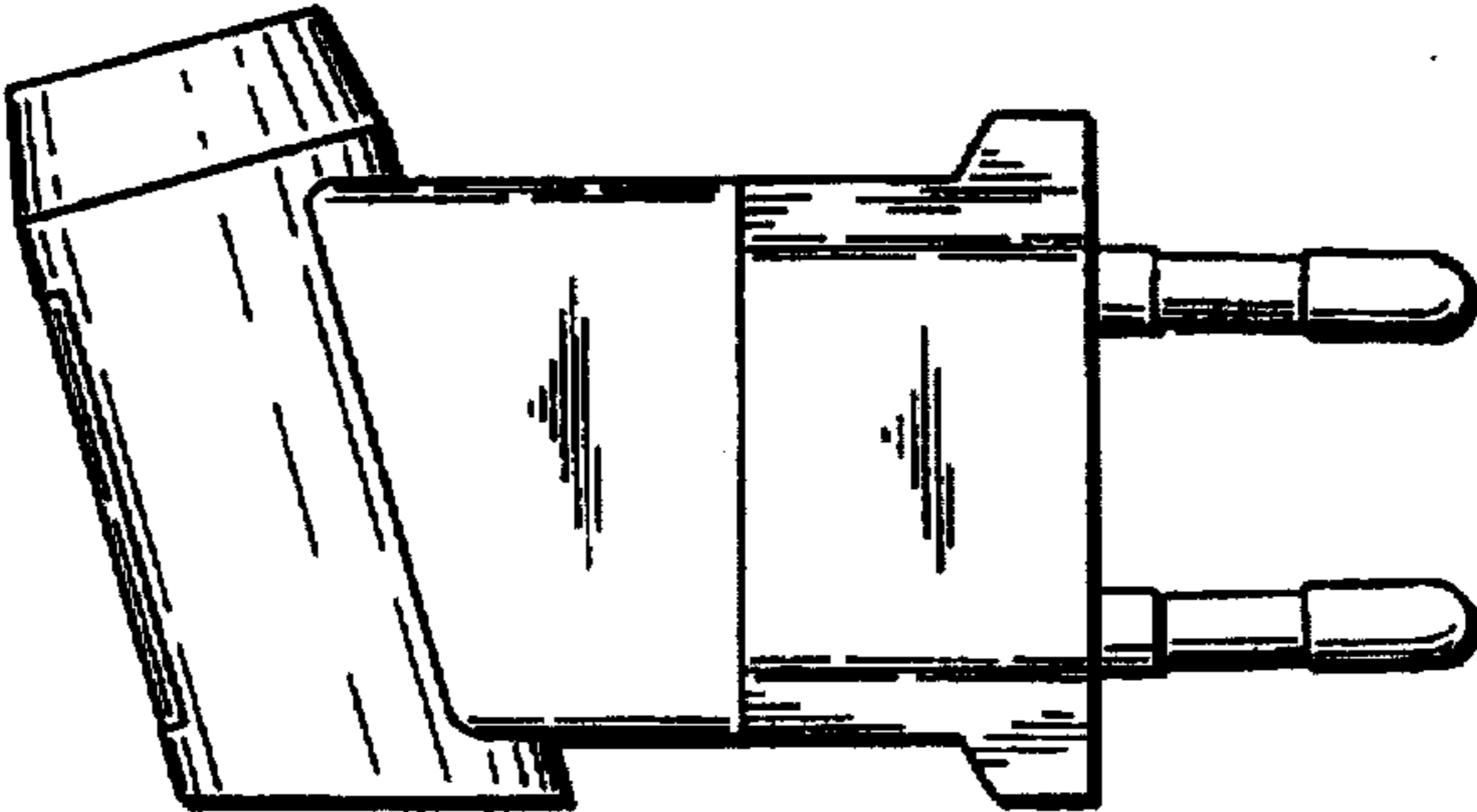

FIG. 11

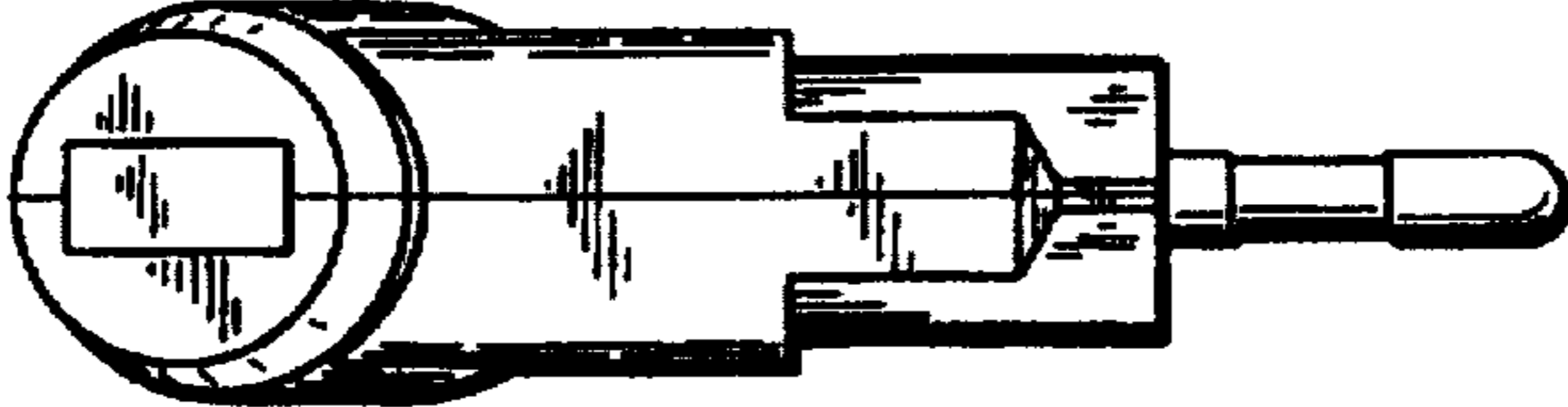

FIG. 12

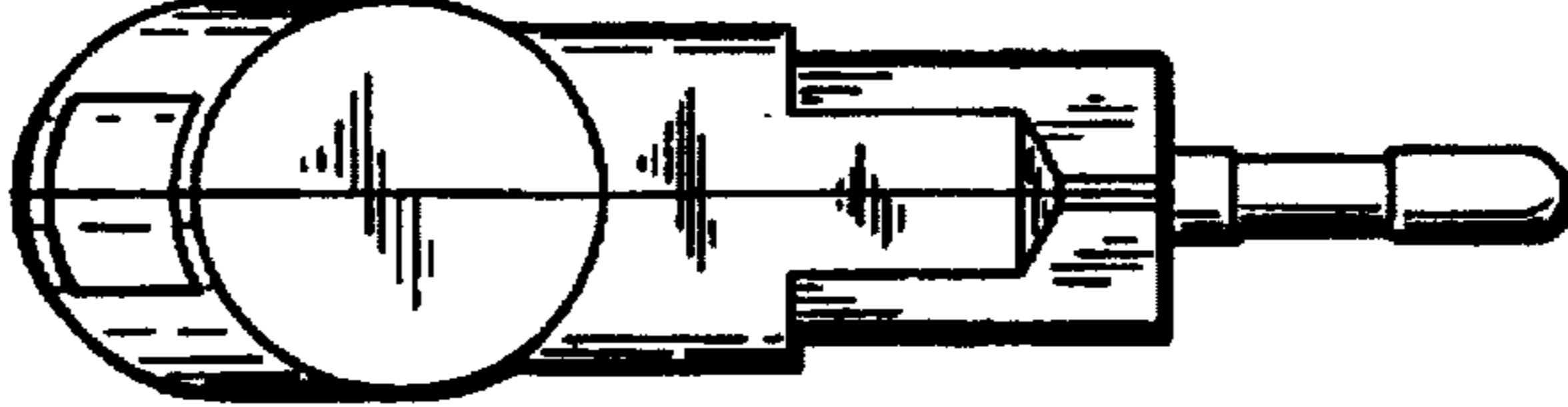

FIG. 13

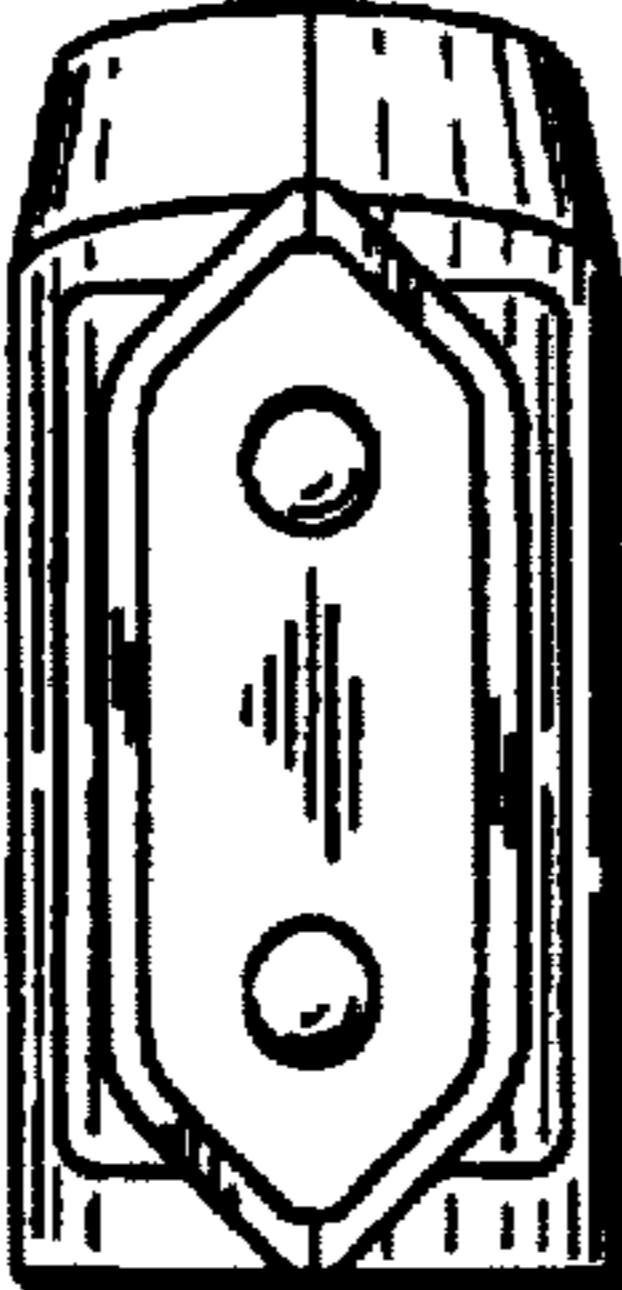

FIG. 14

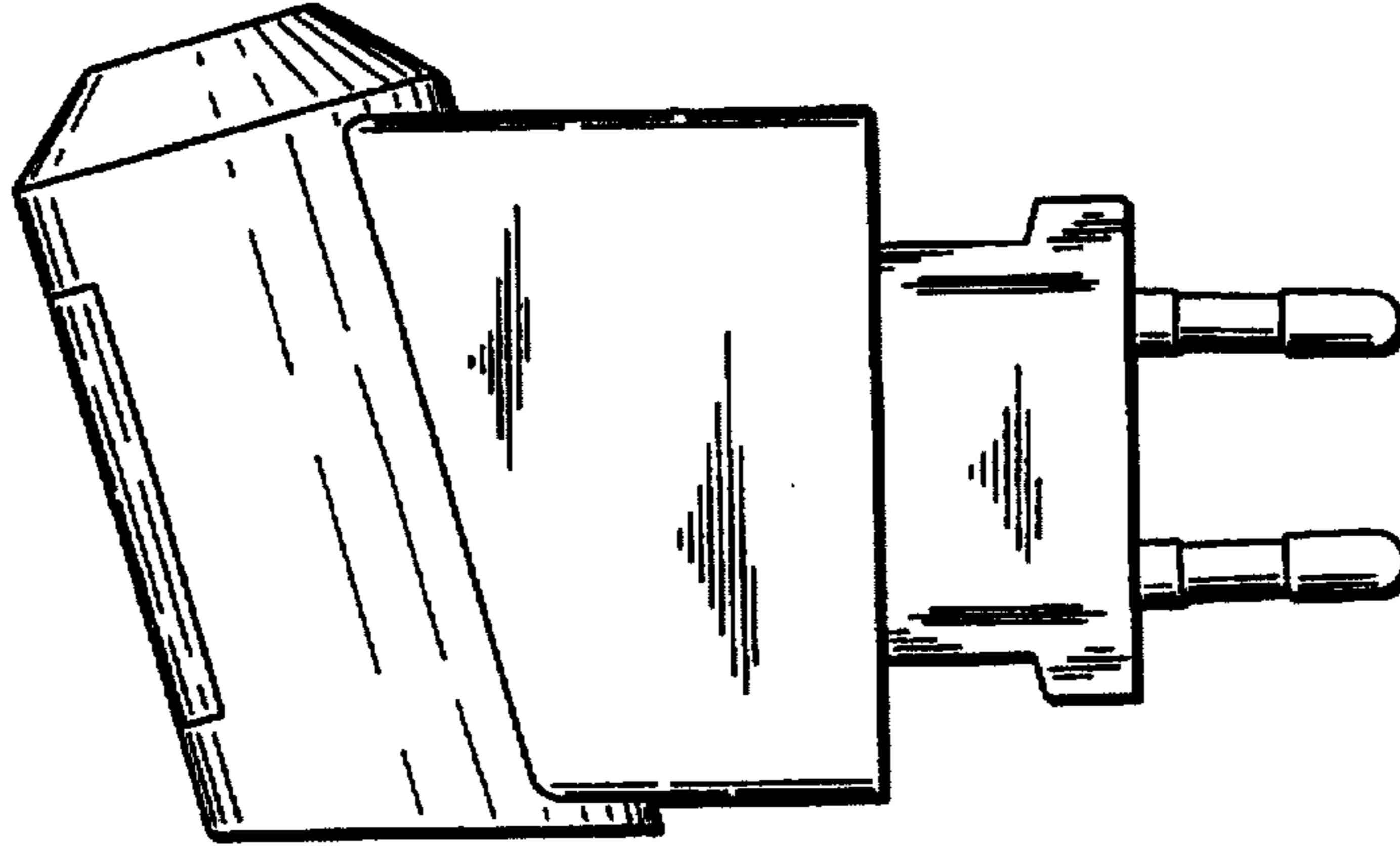

FIG. 15

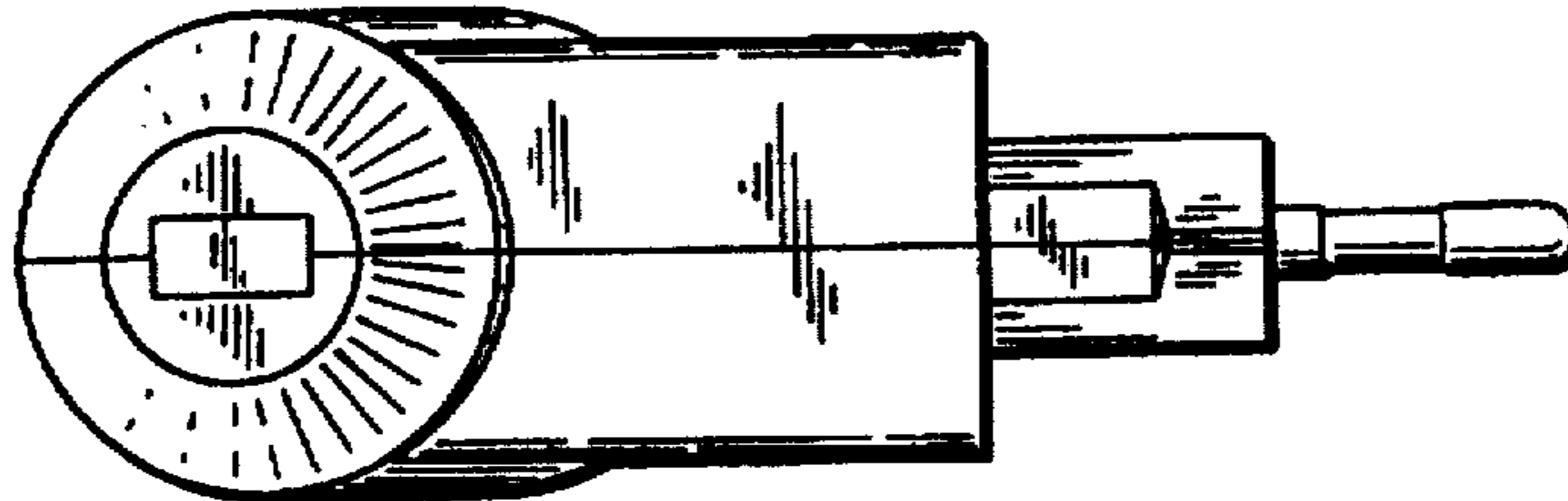

FIG. 16

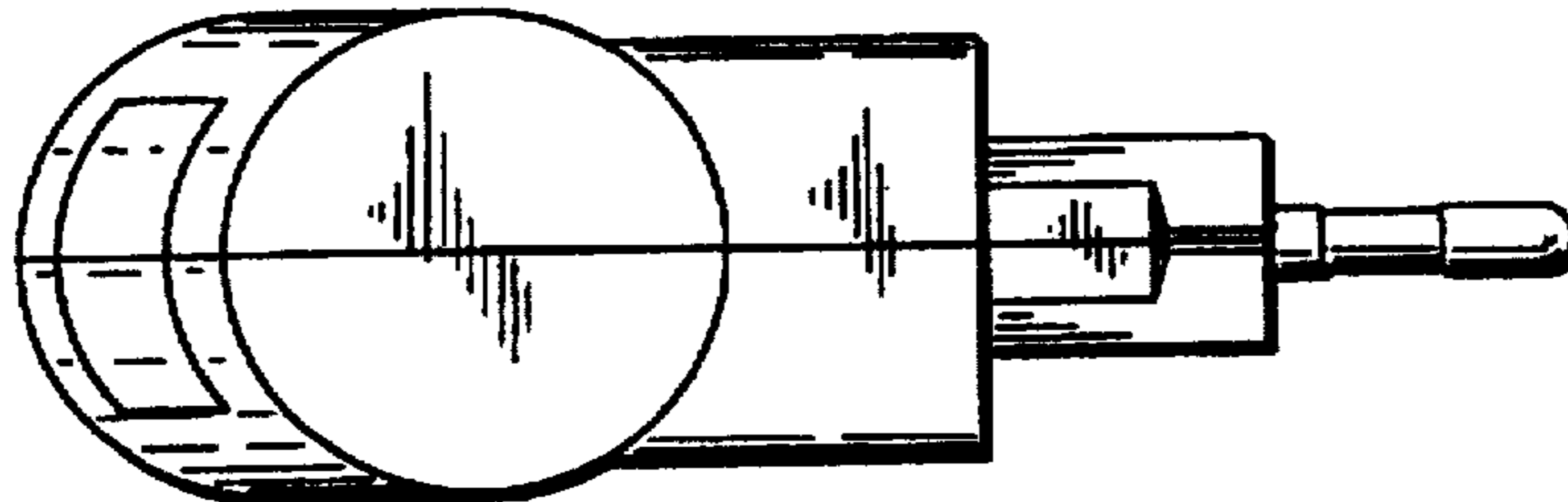
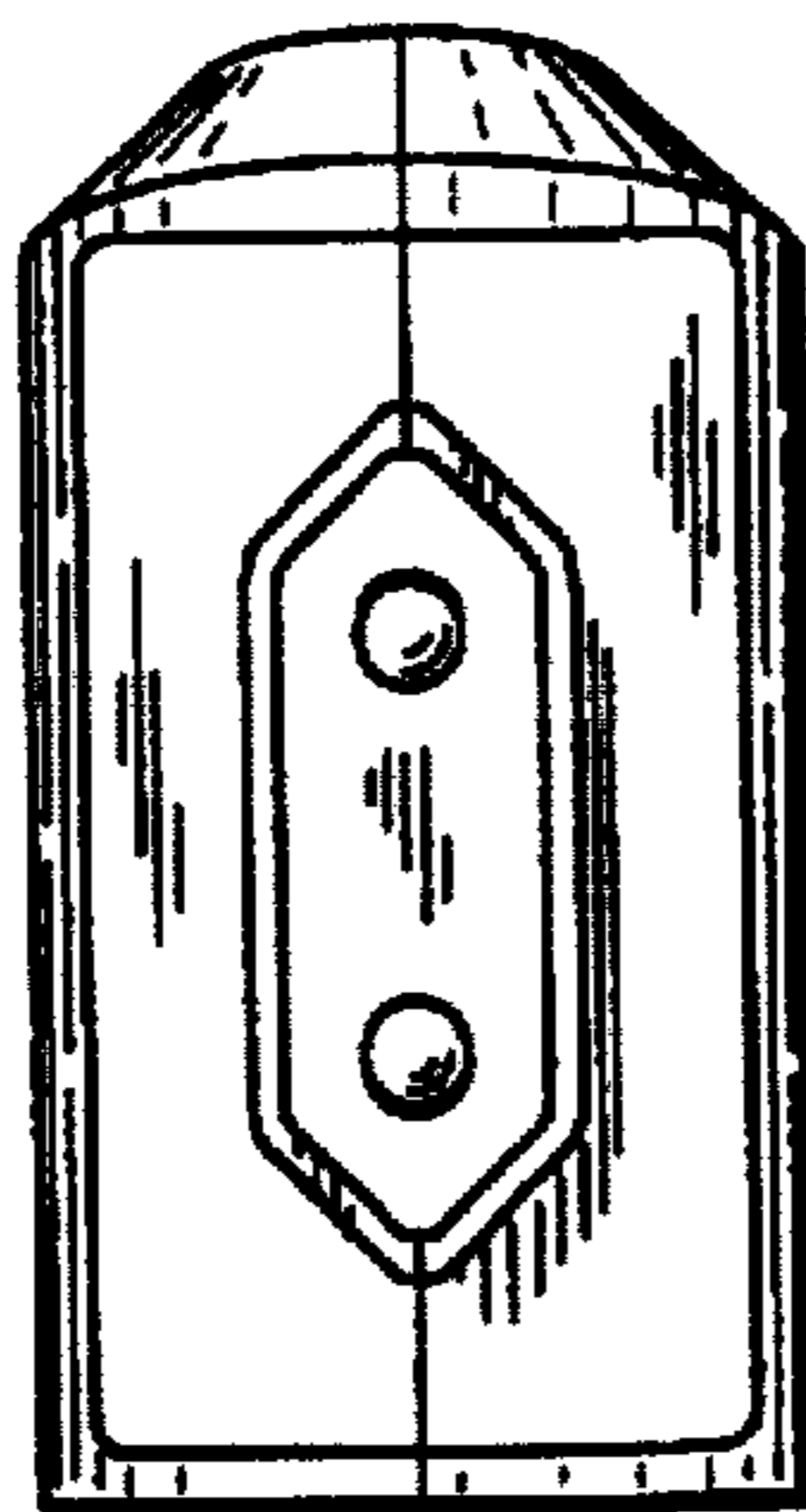

FIG. 17



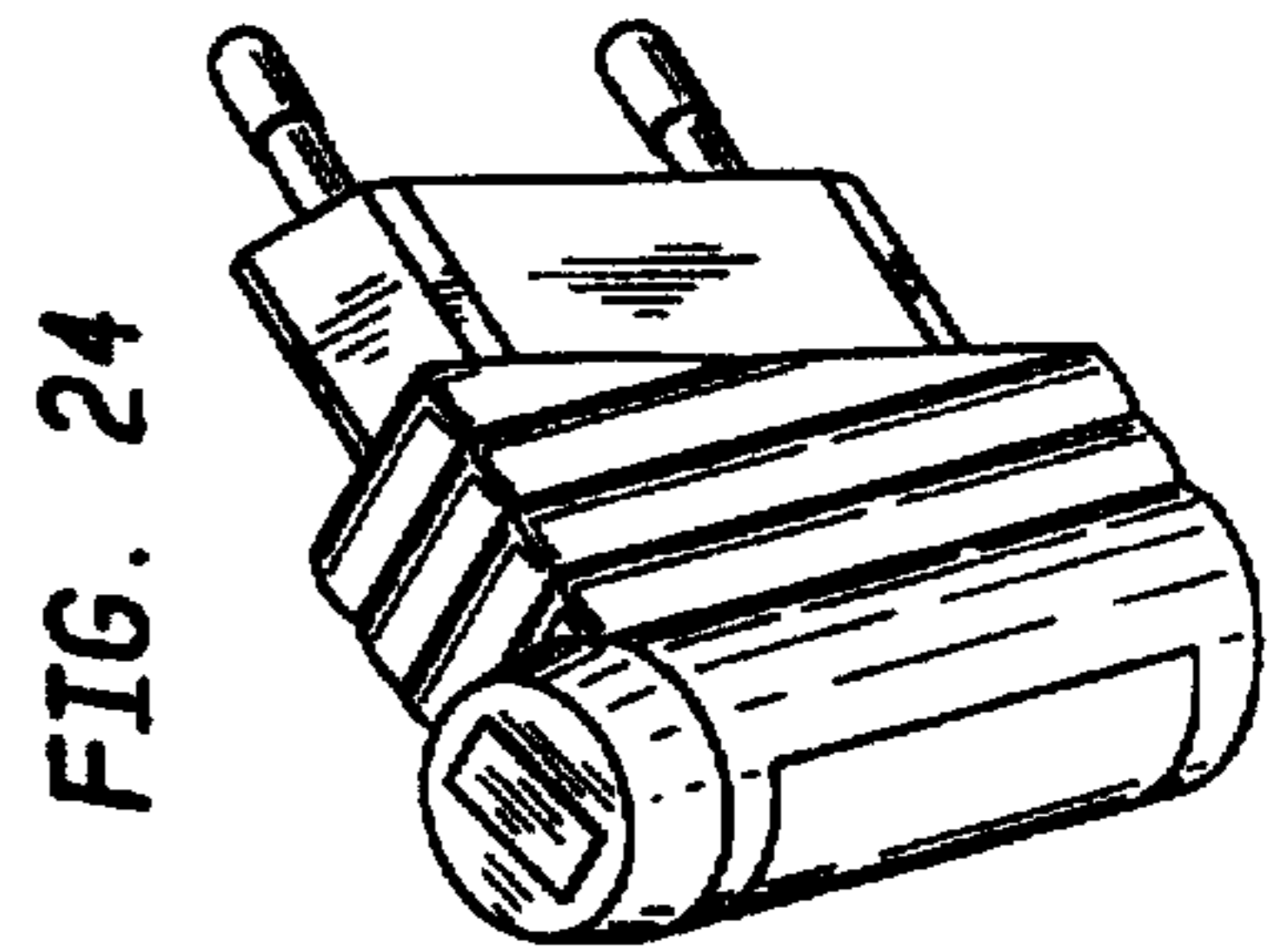
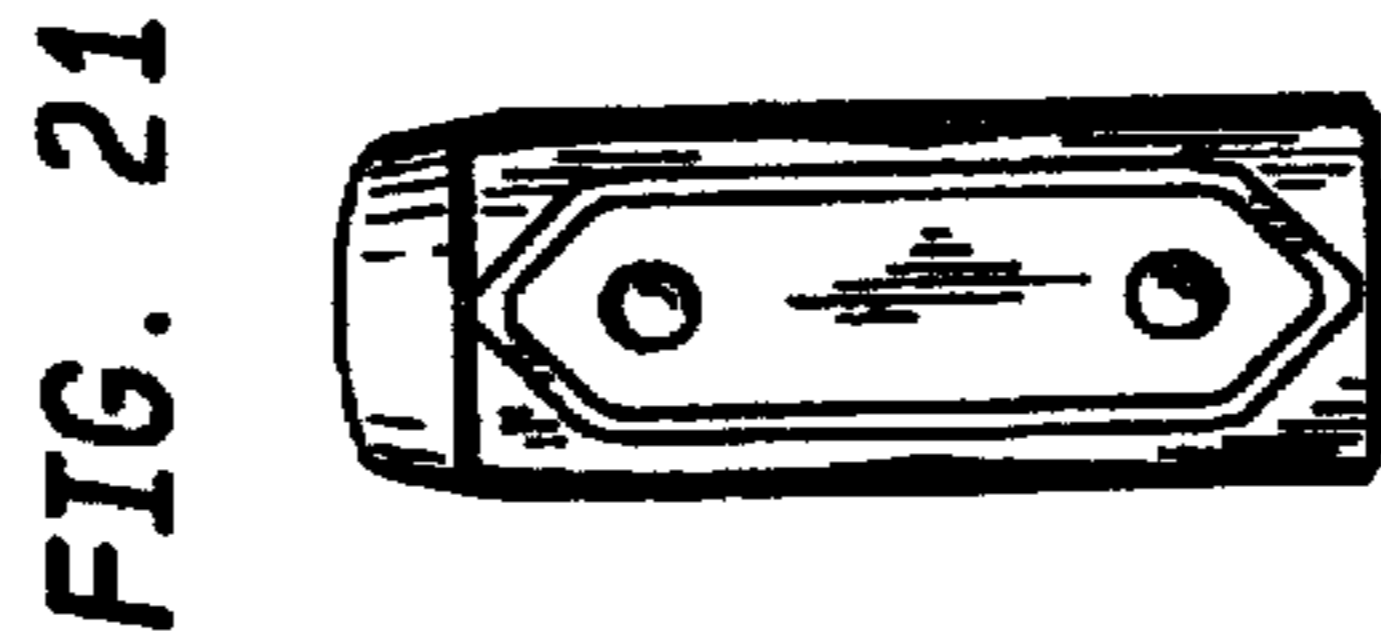
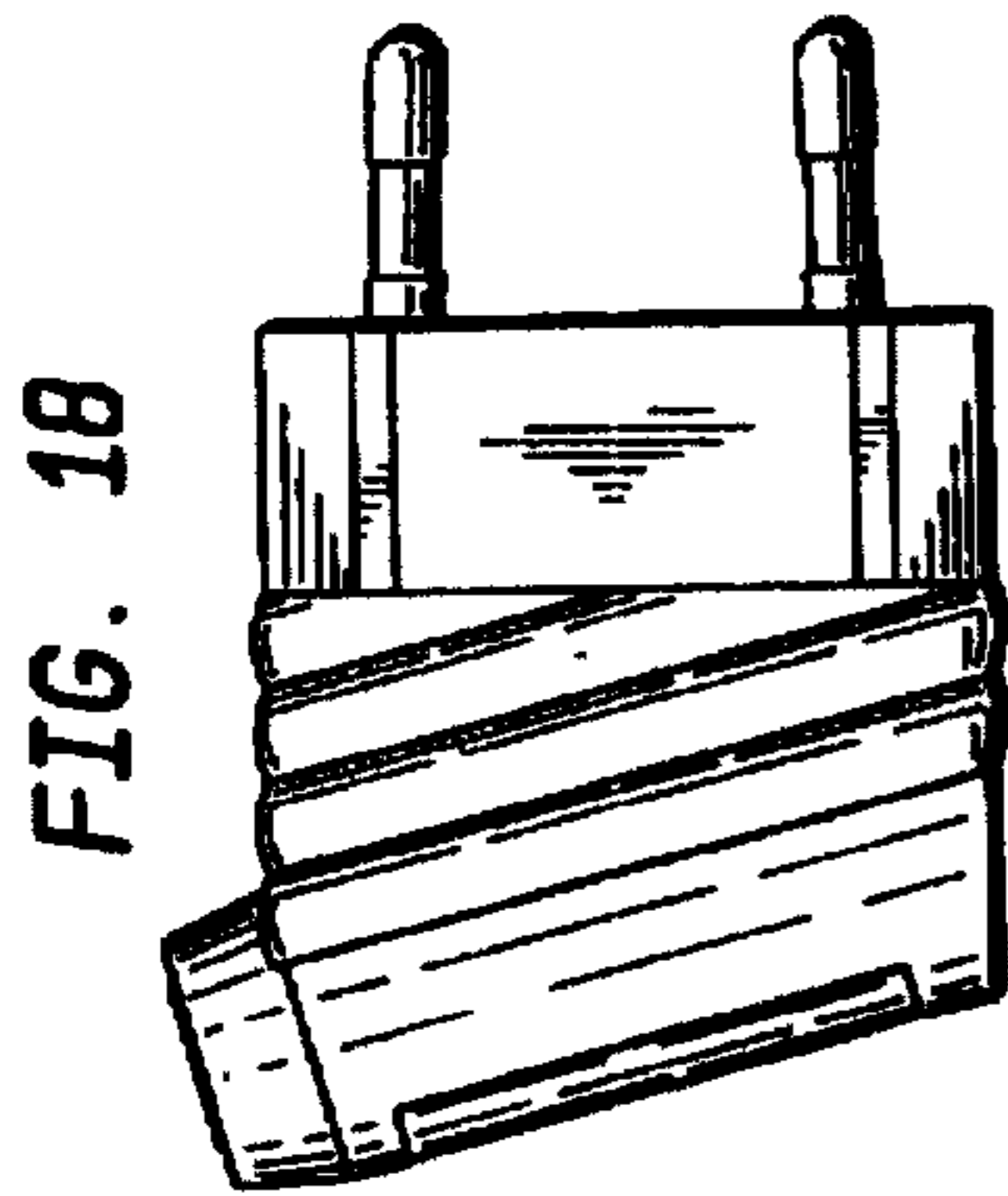
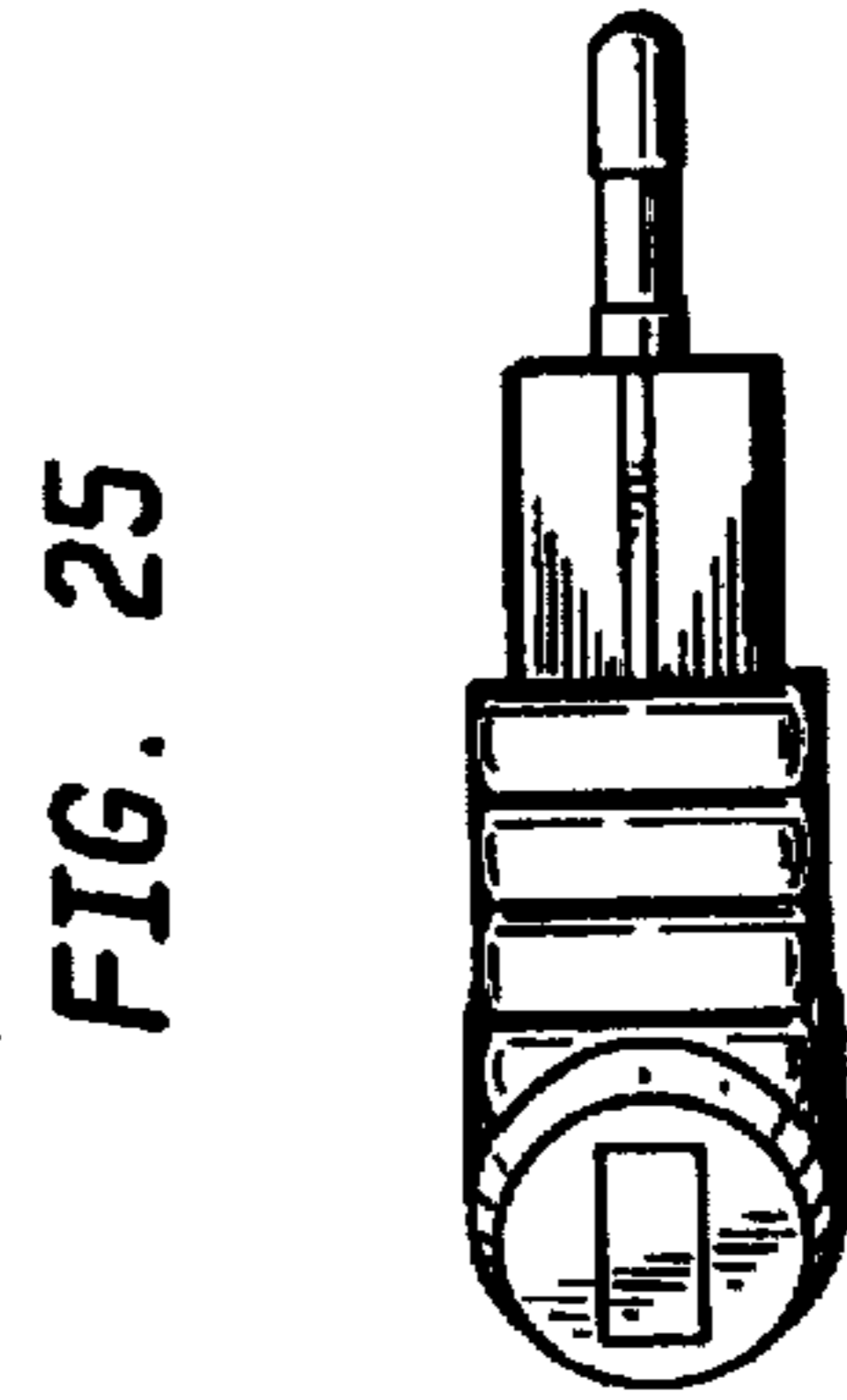
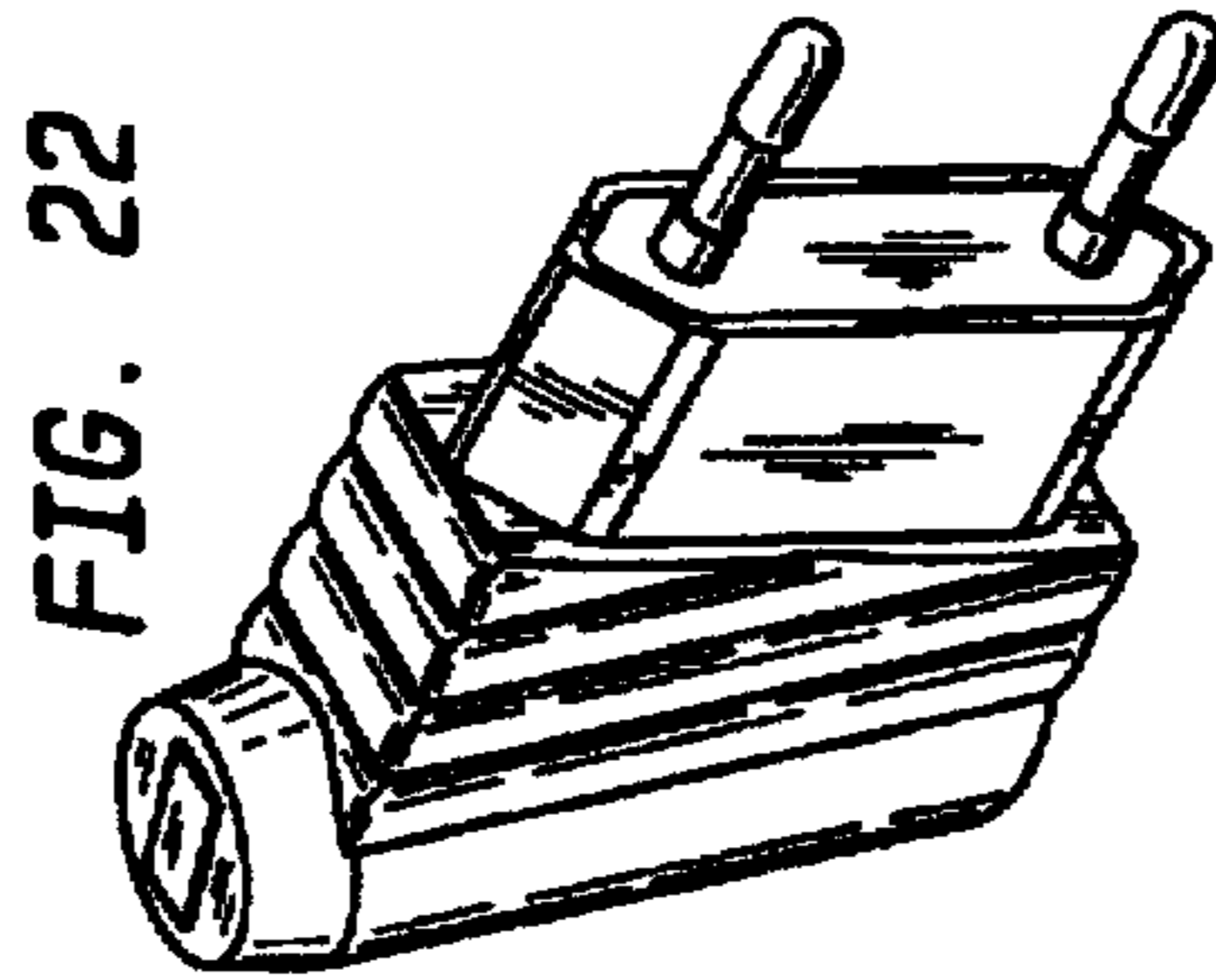
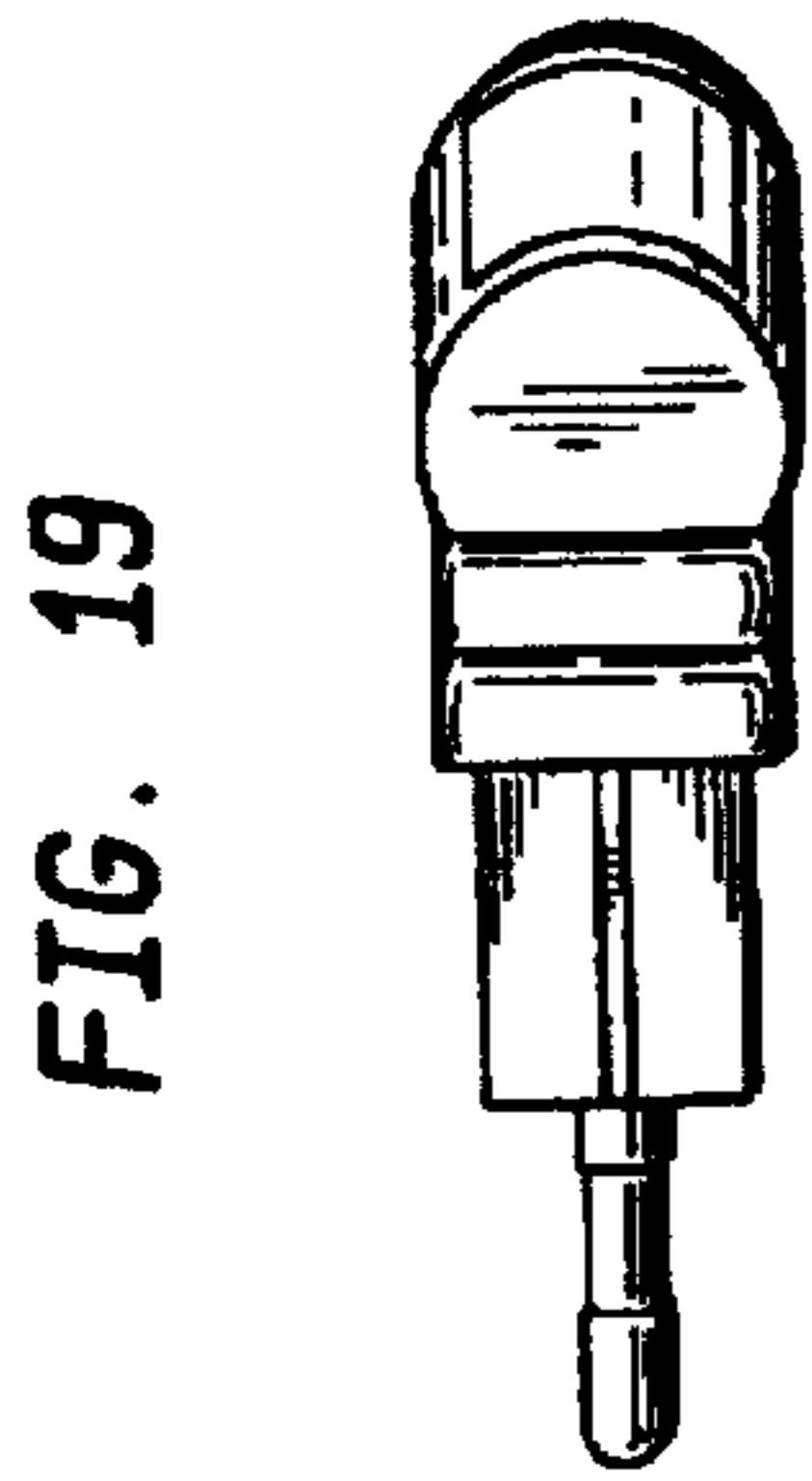
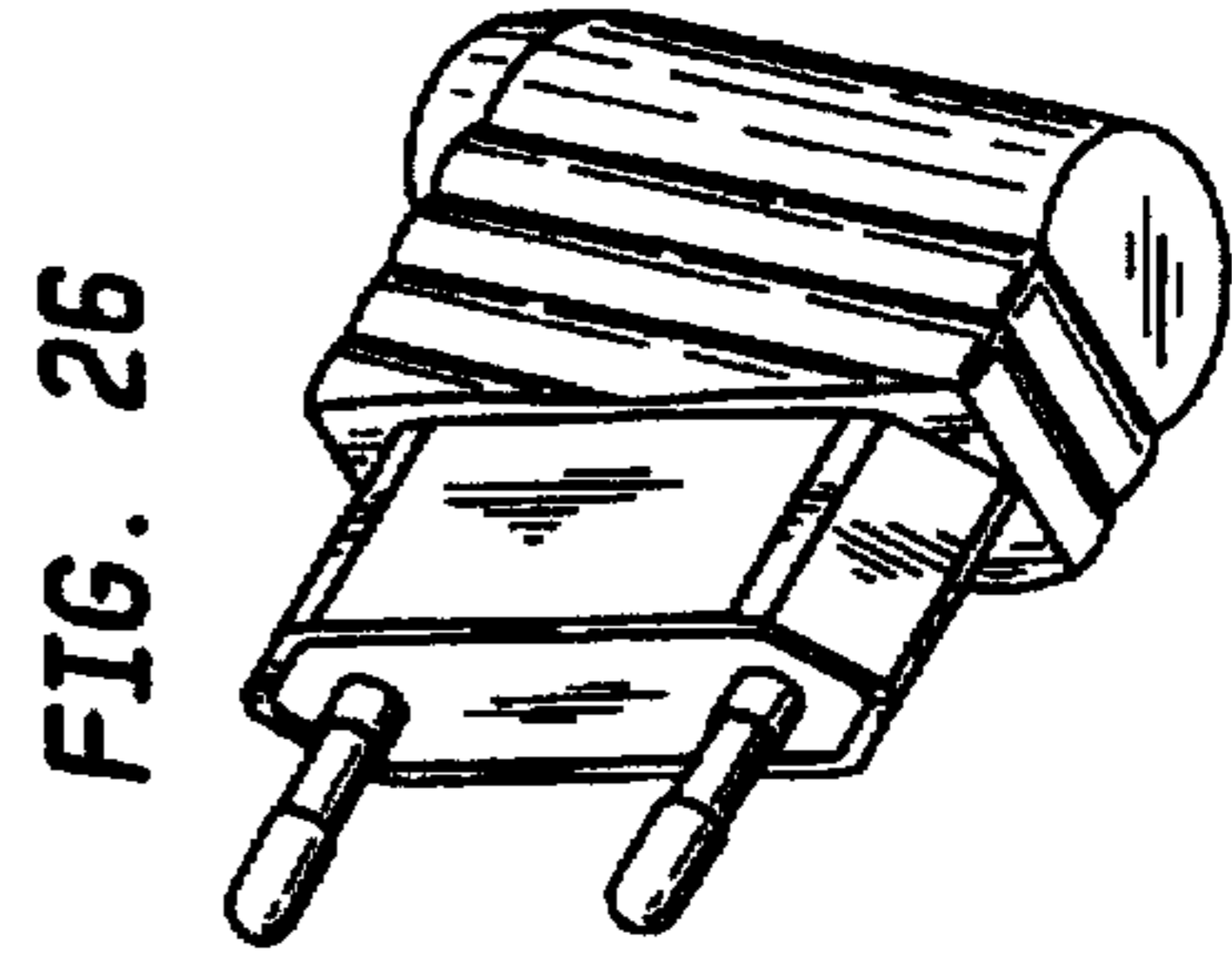
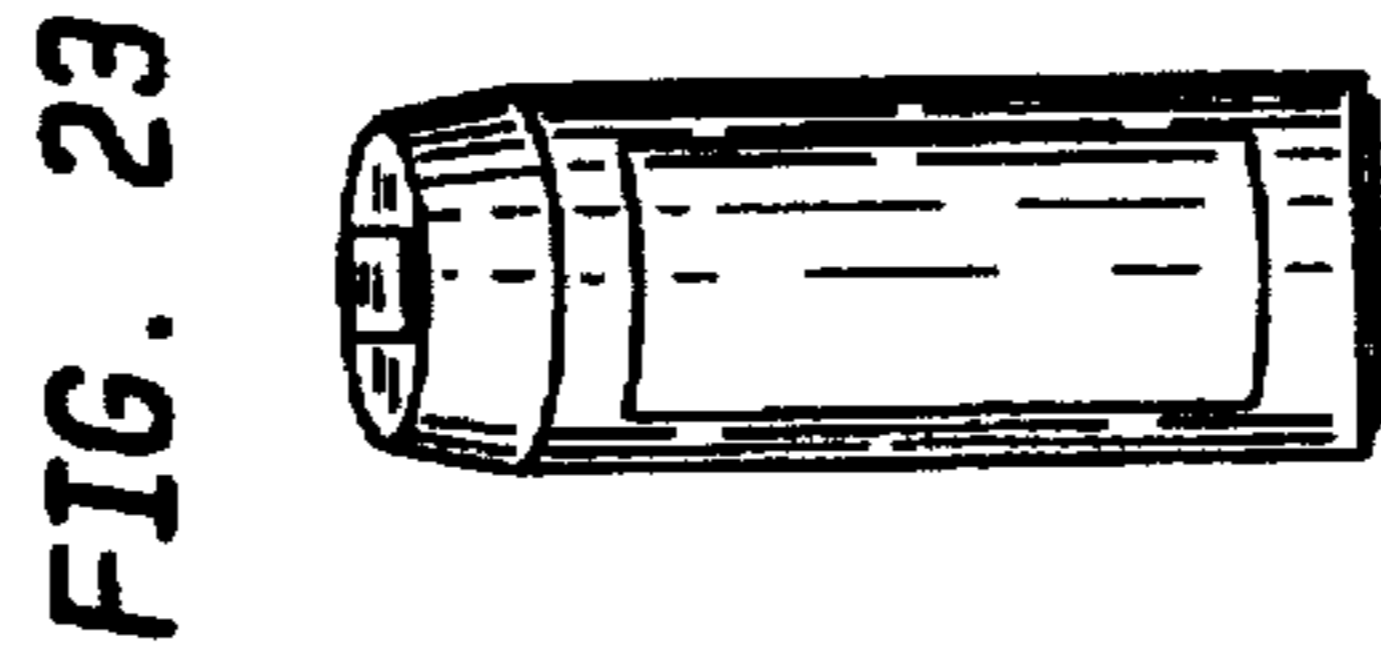
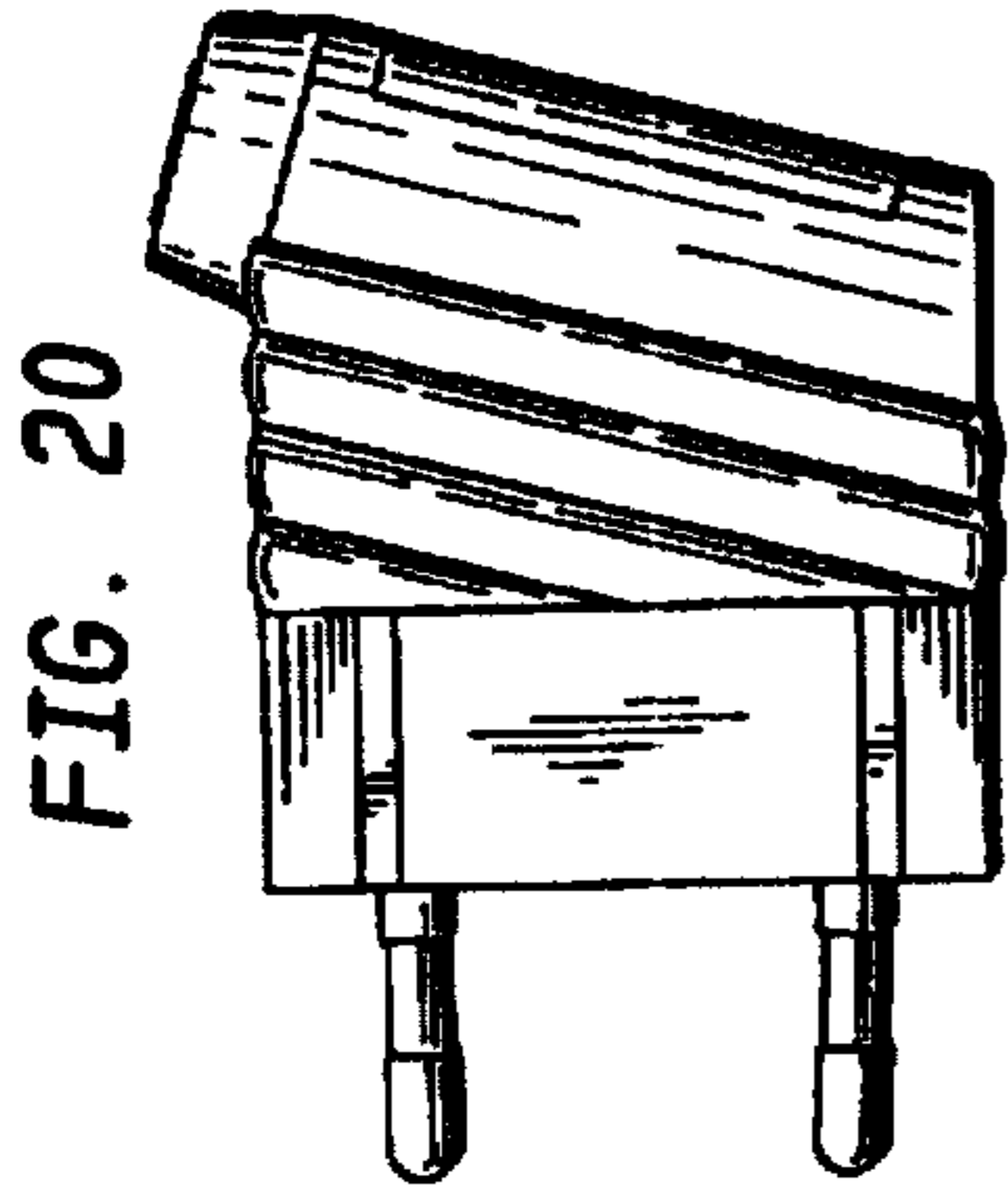

FIG. 27

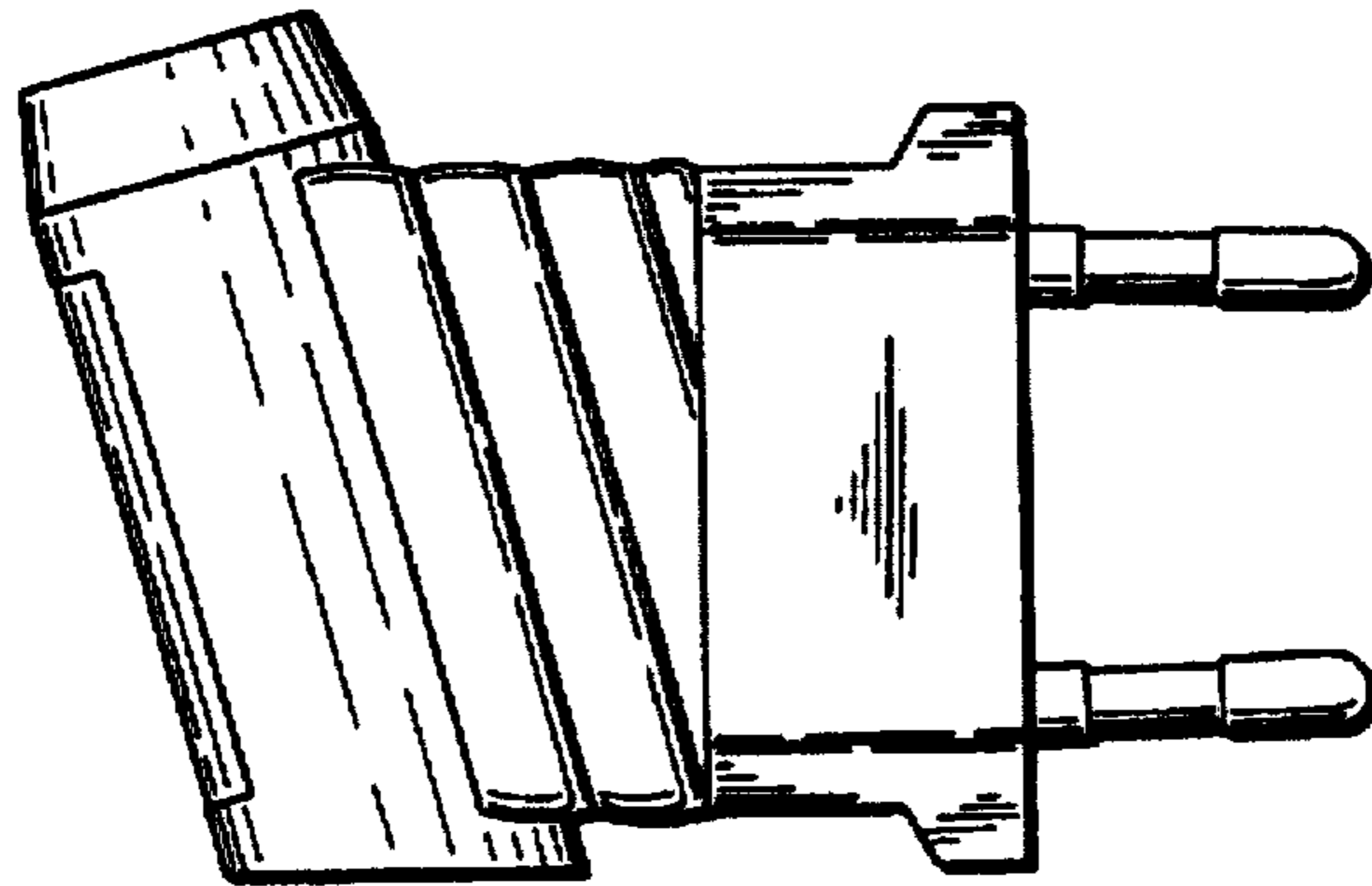

FIG. 28

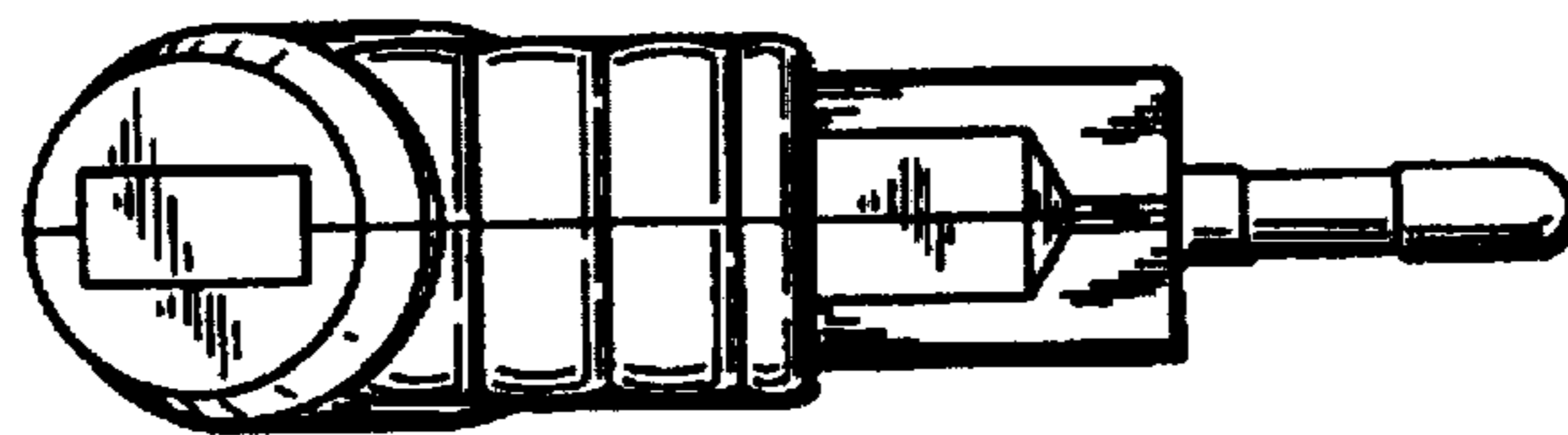

FIG. 29

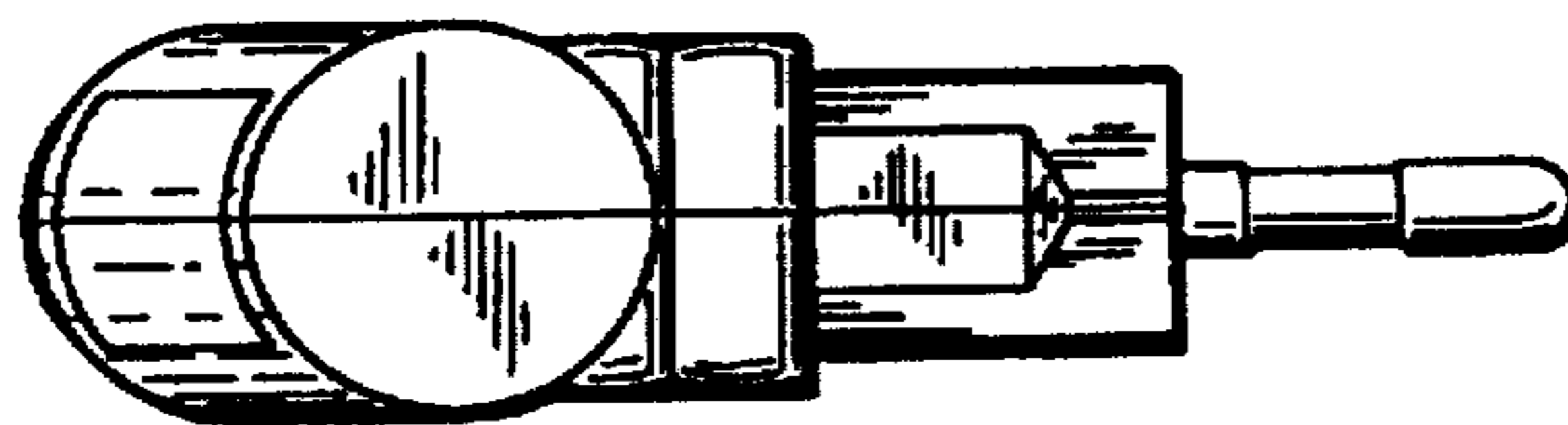

FIG. 30

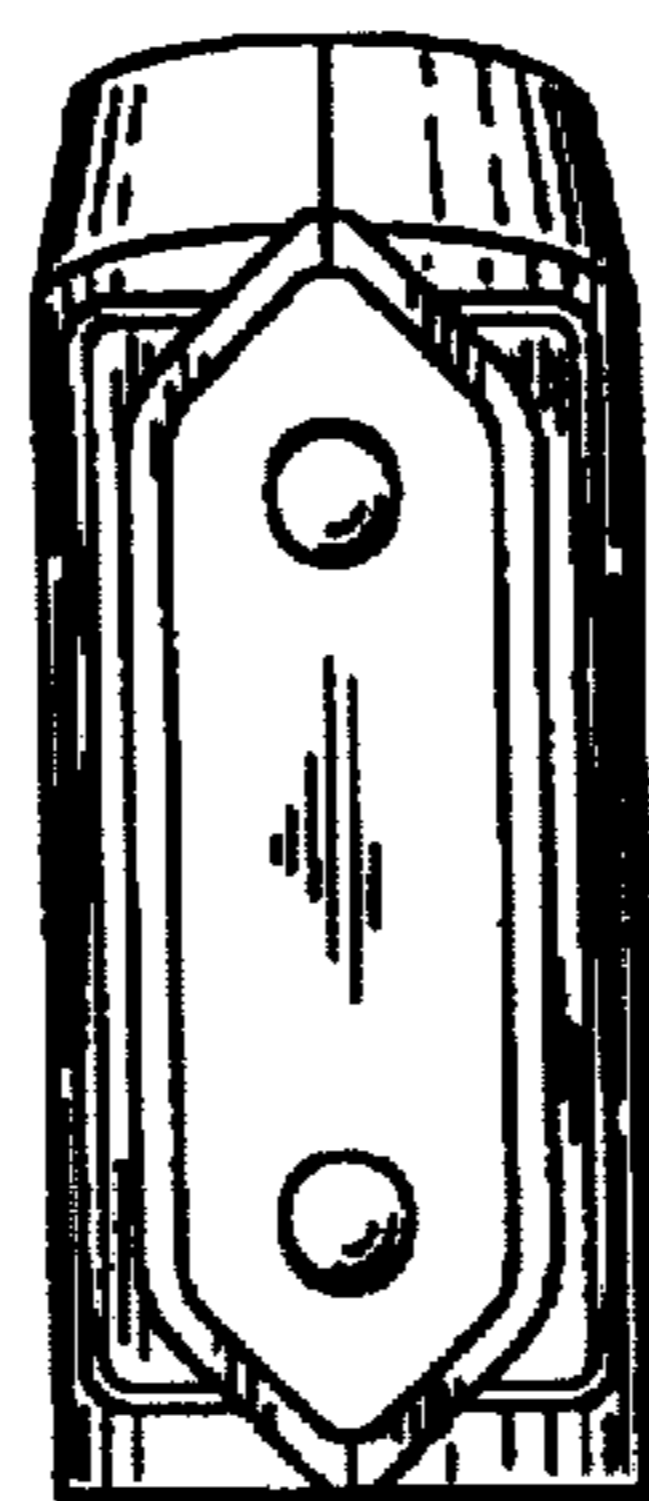

FIG. 31

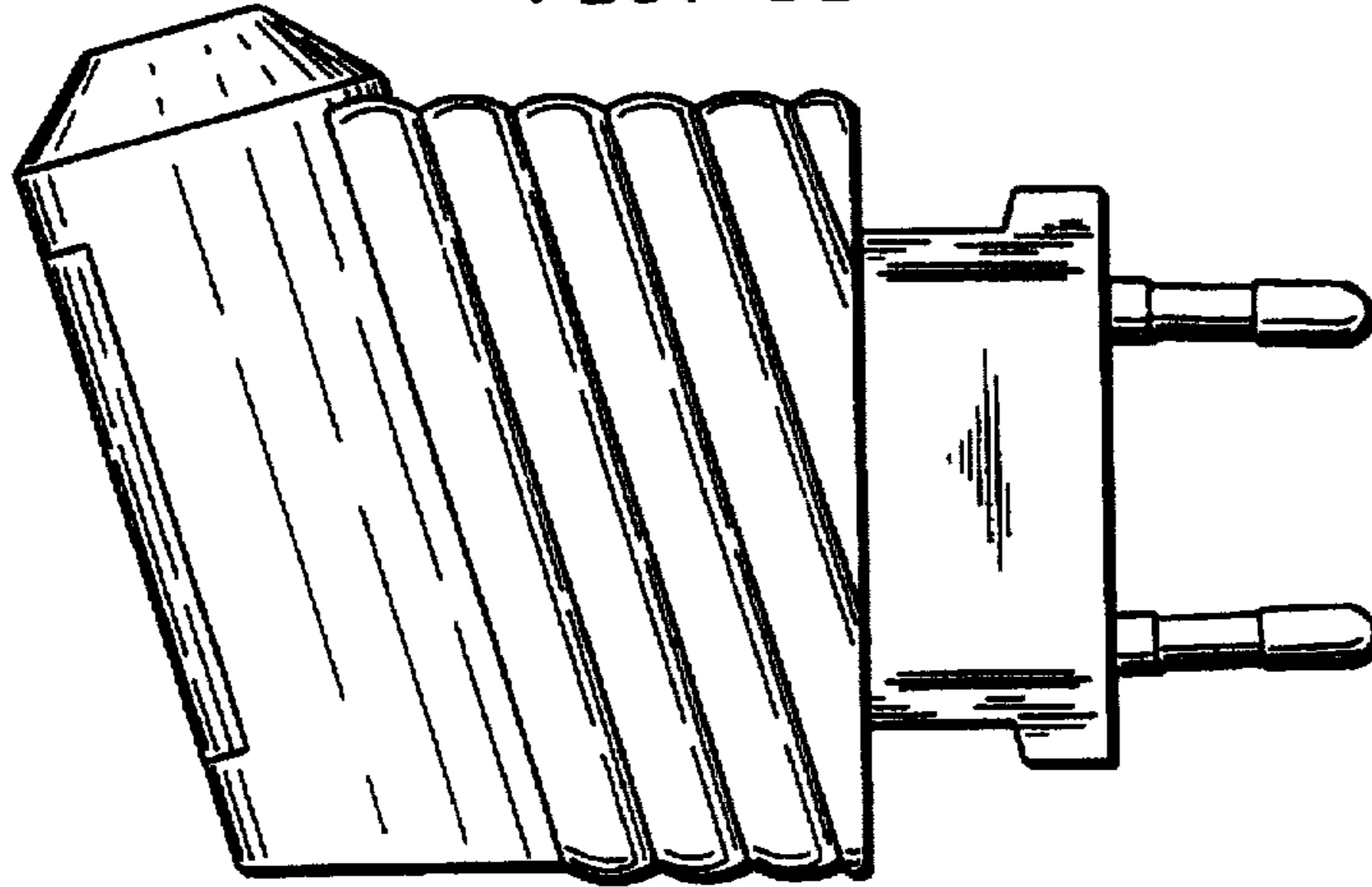

FIG. 32

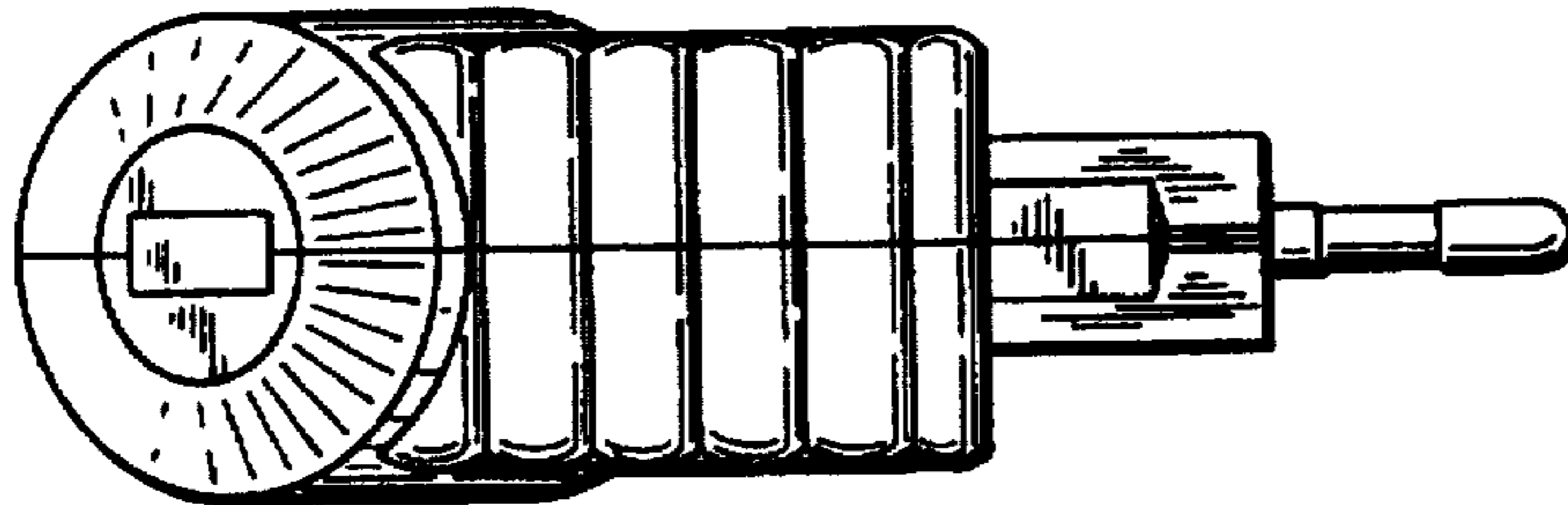

FIG. 33

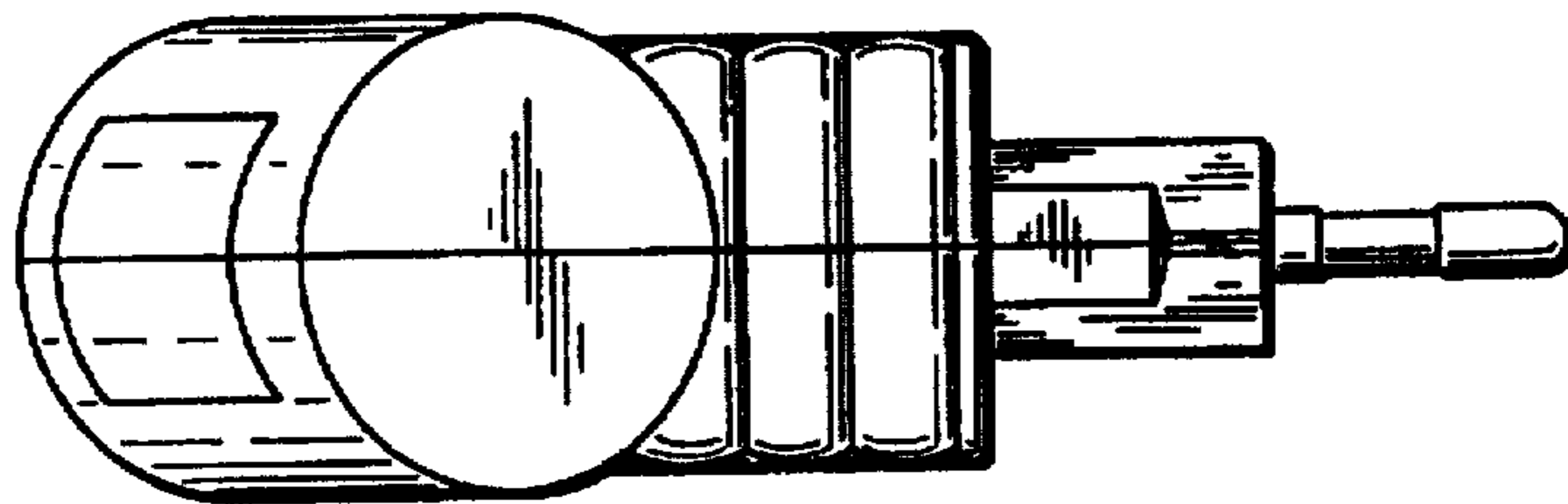
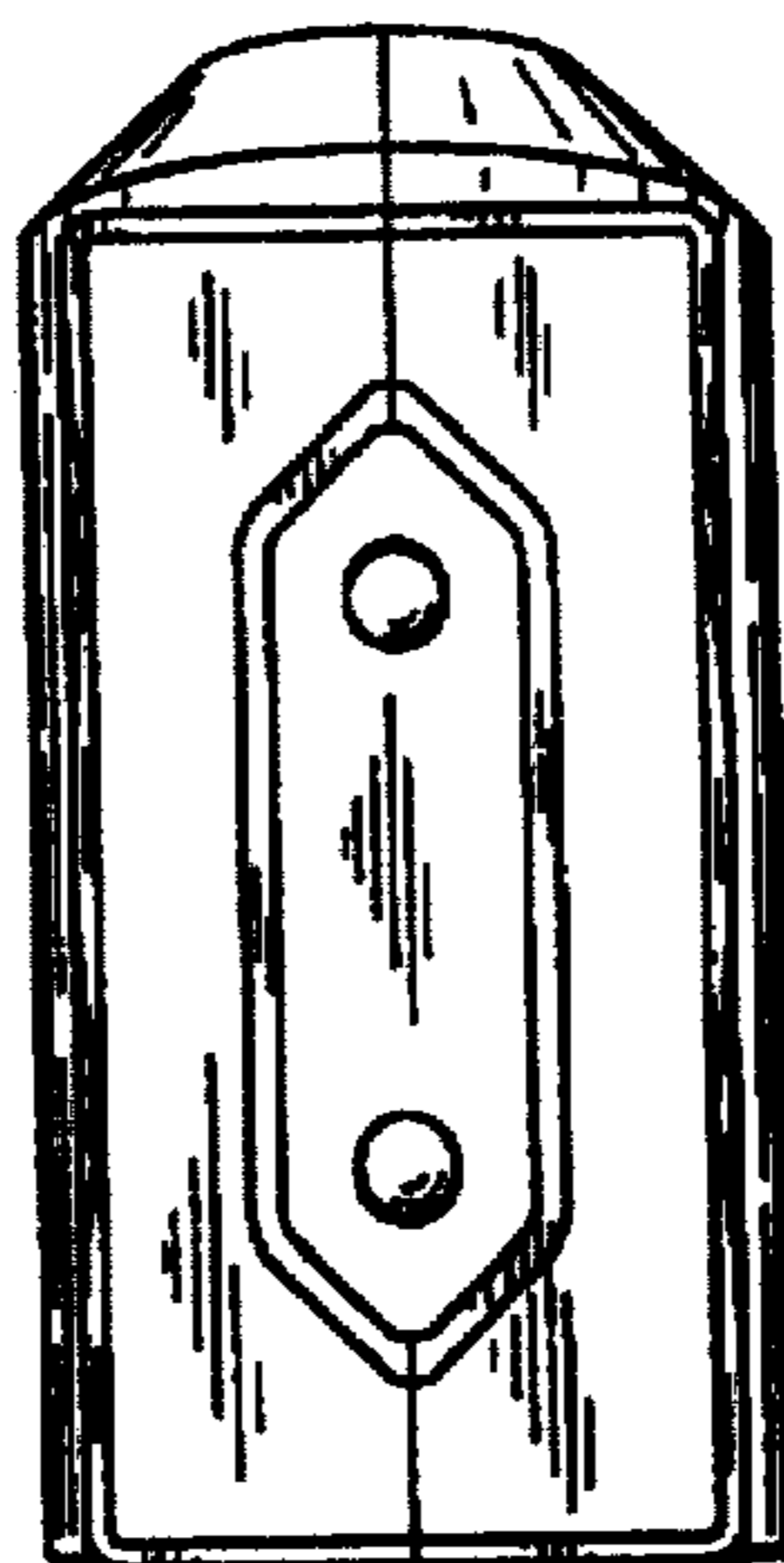

FIG. 34



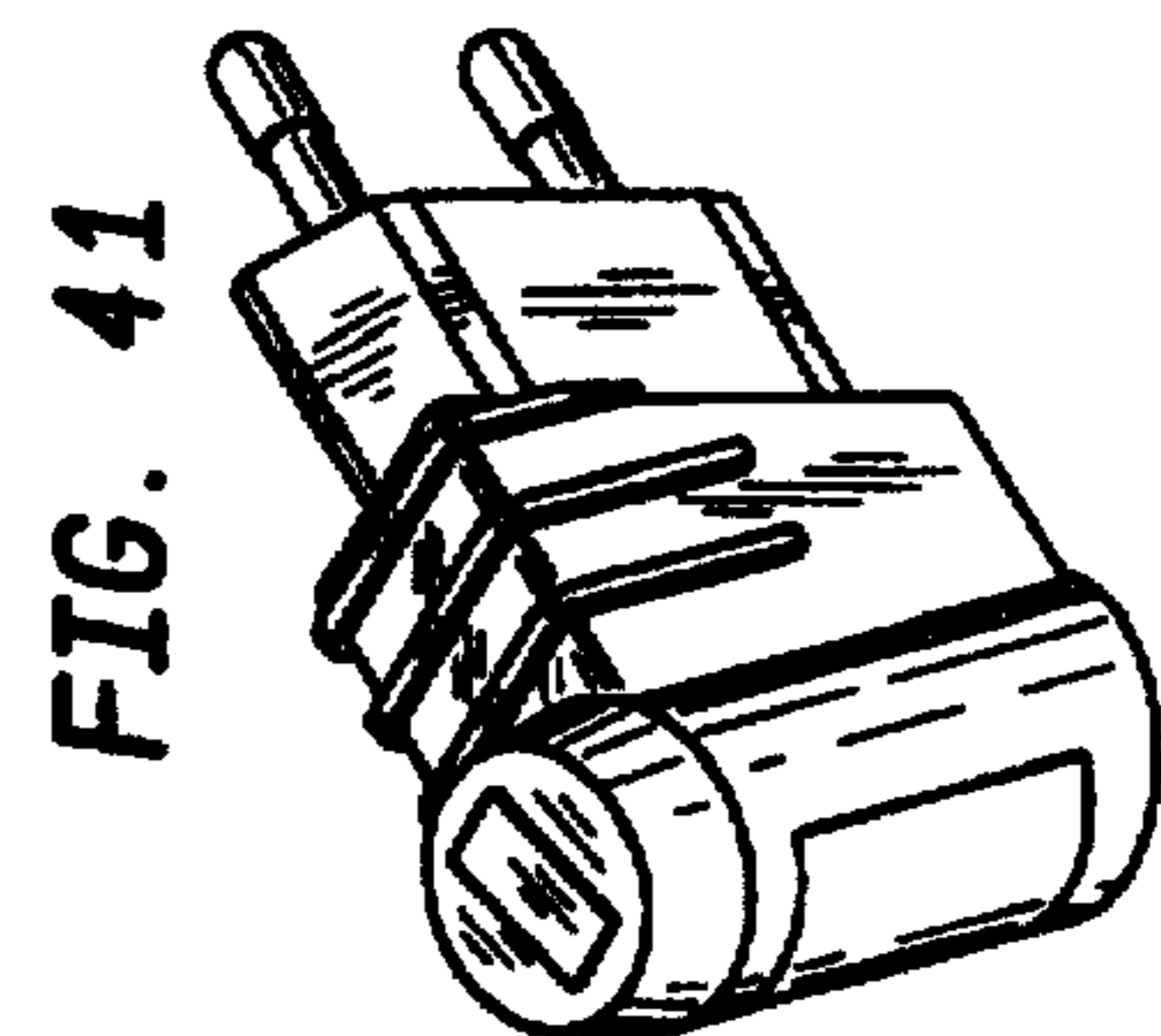
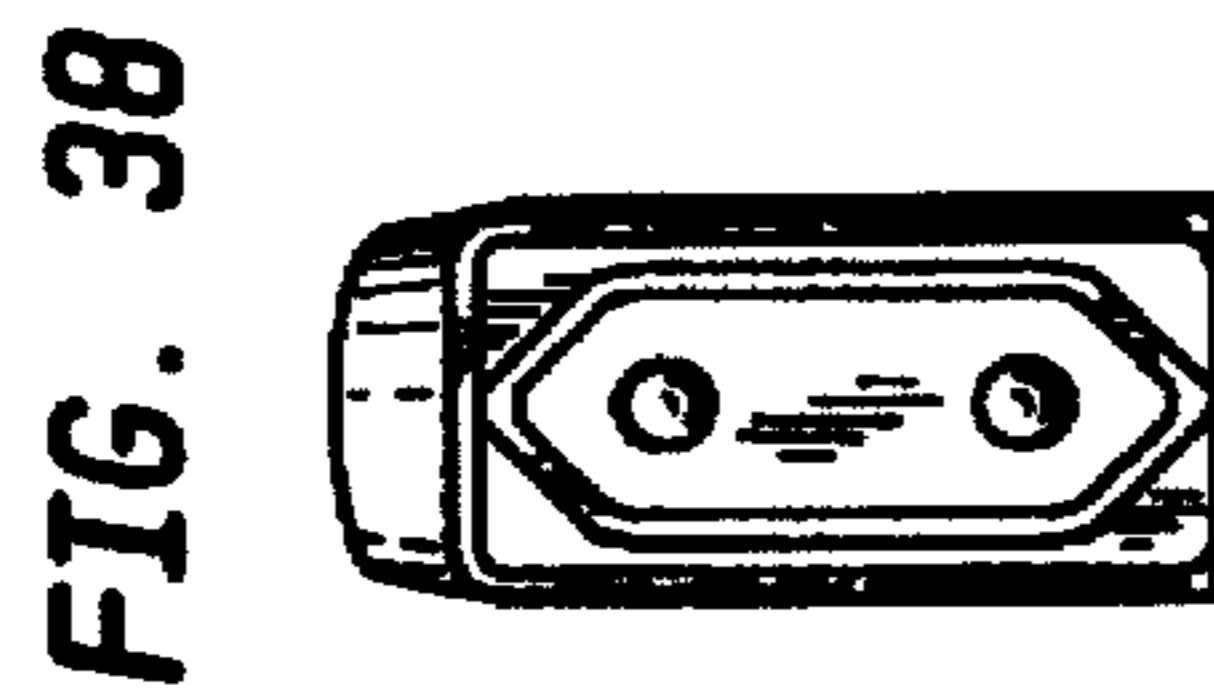
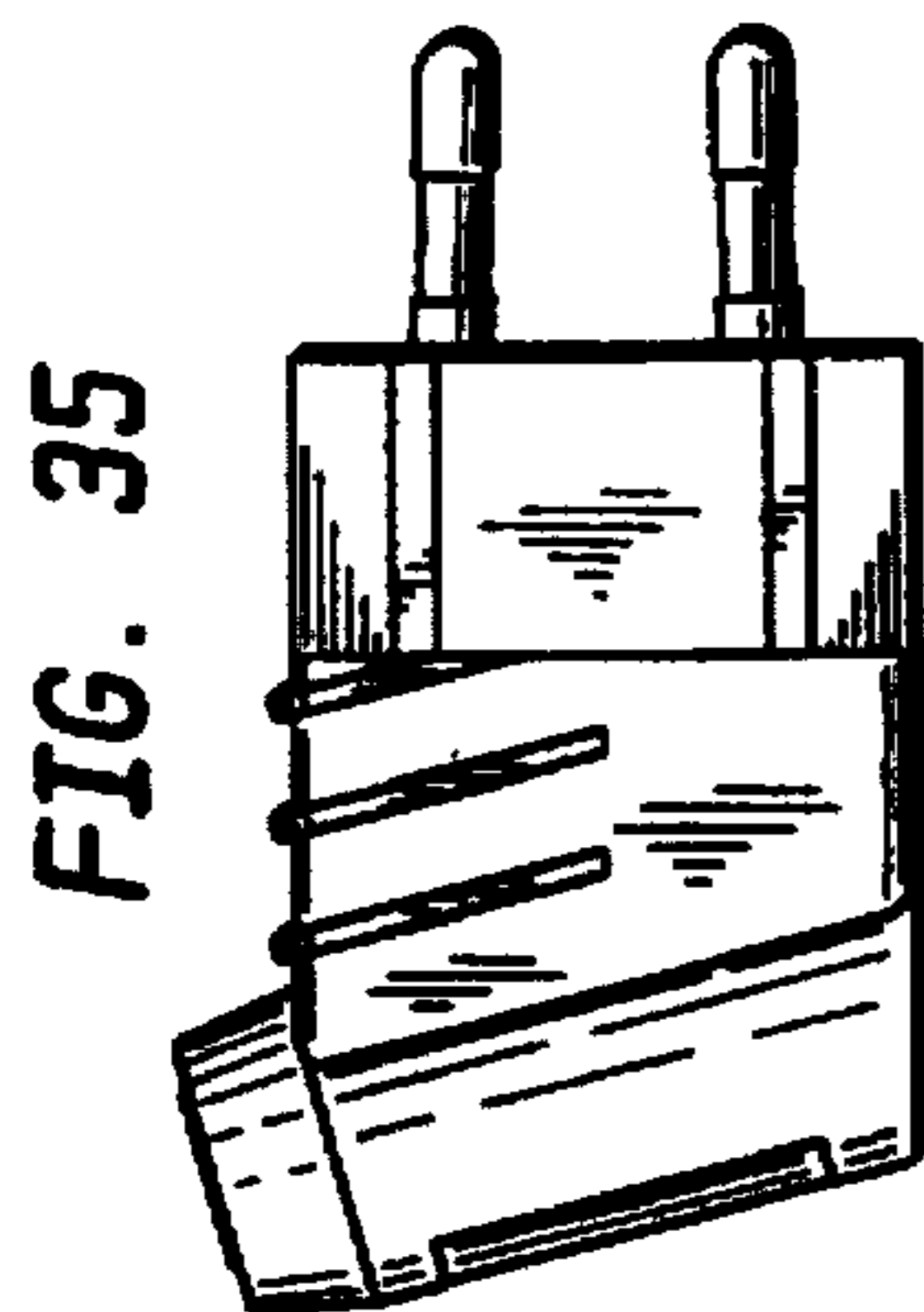
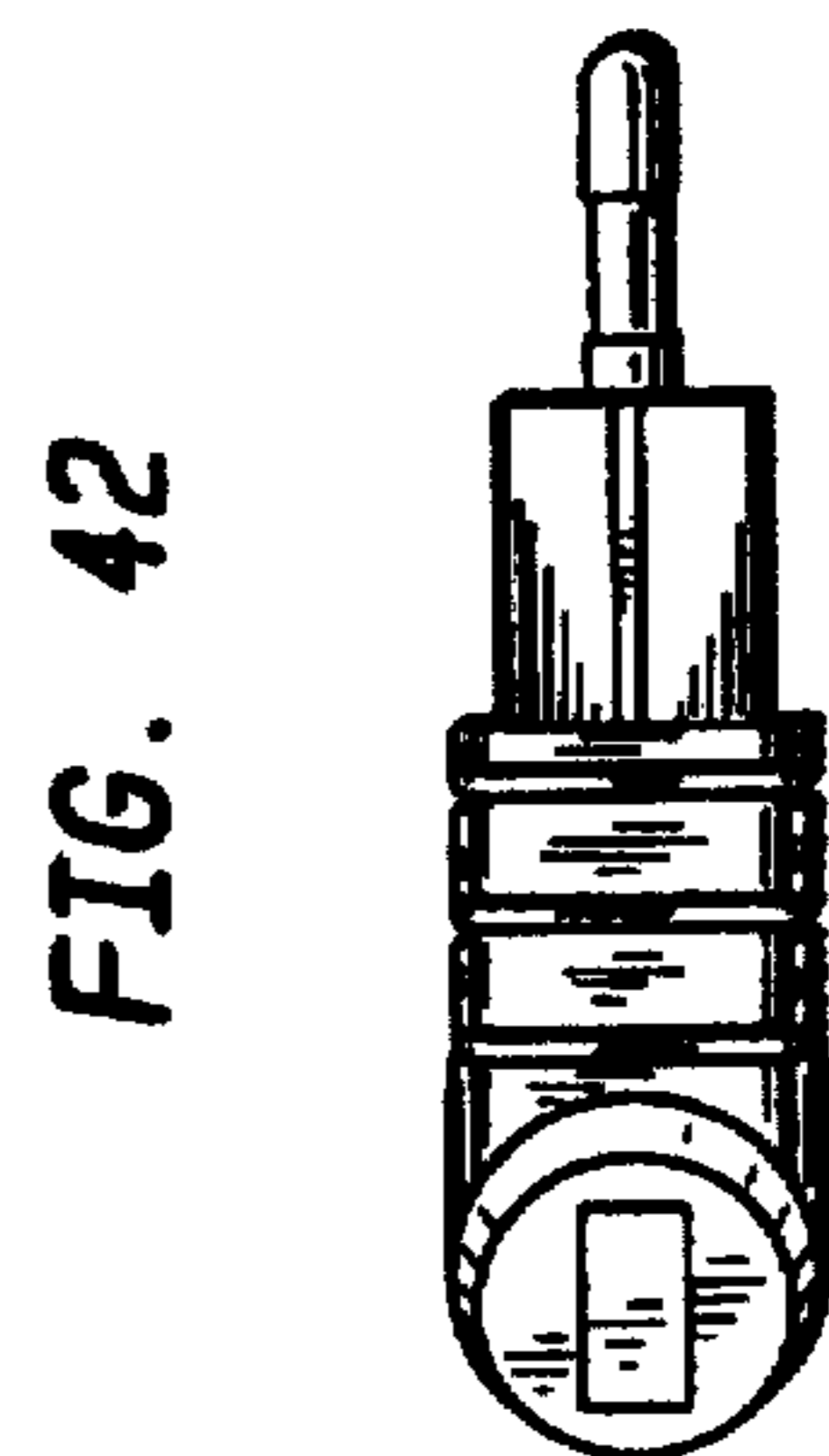
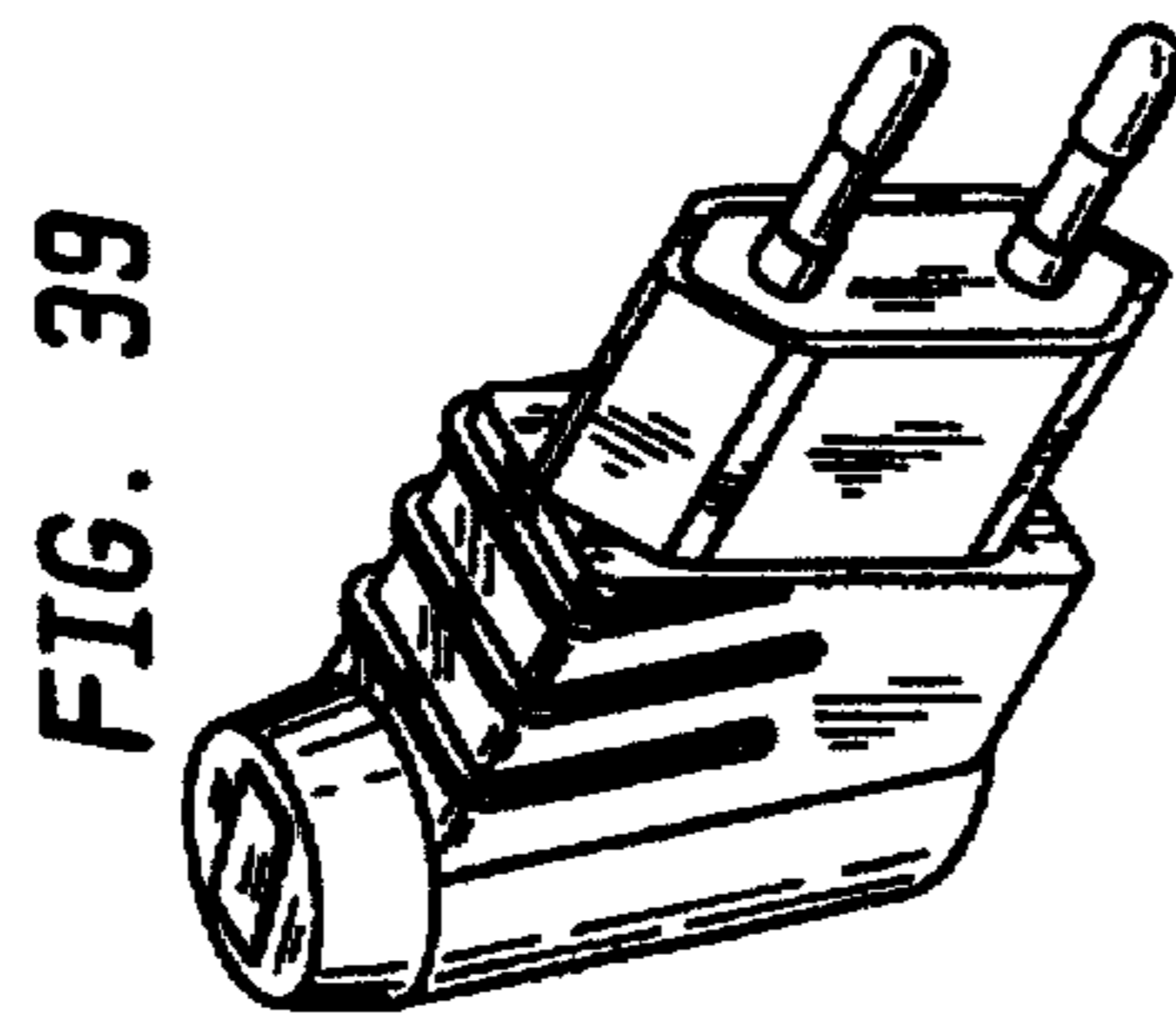
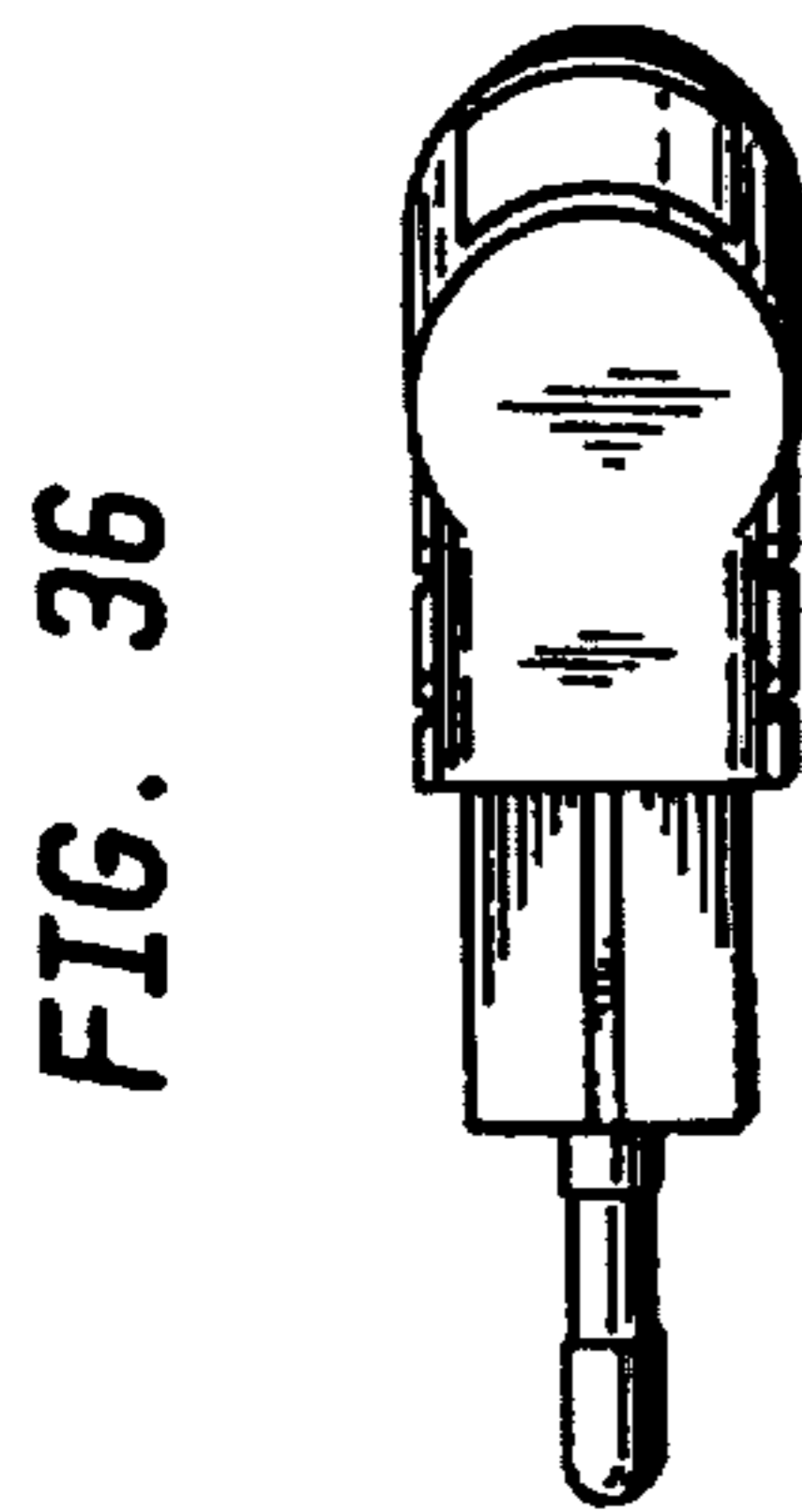
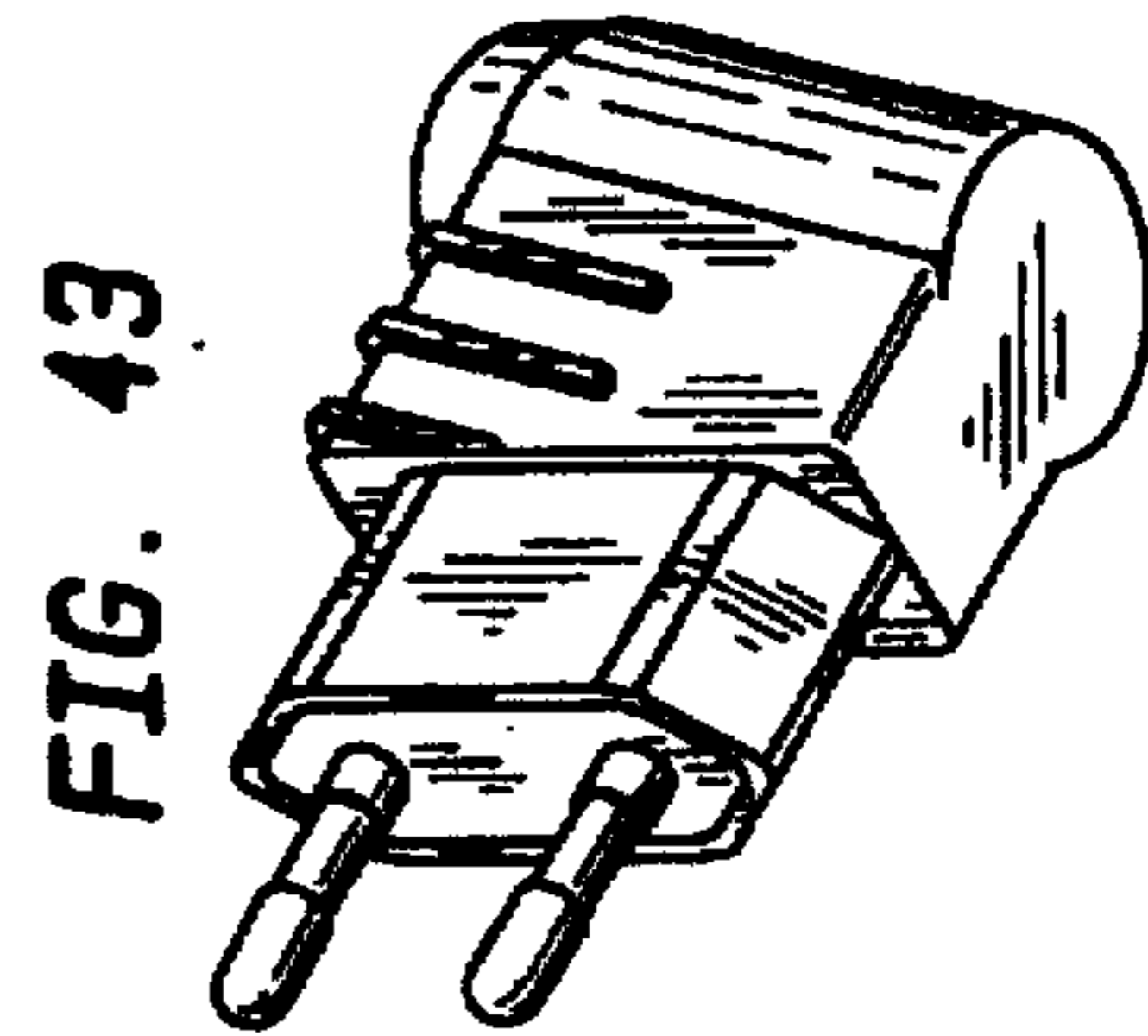
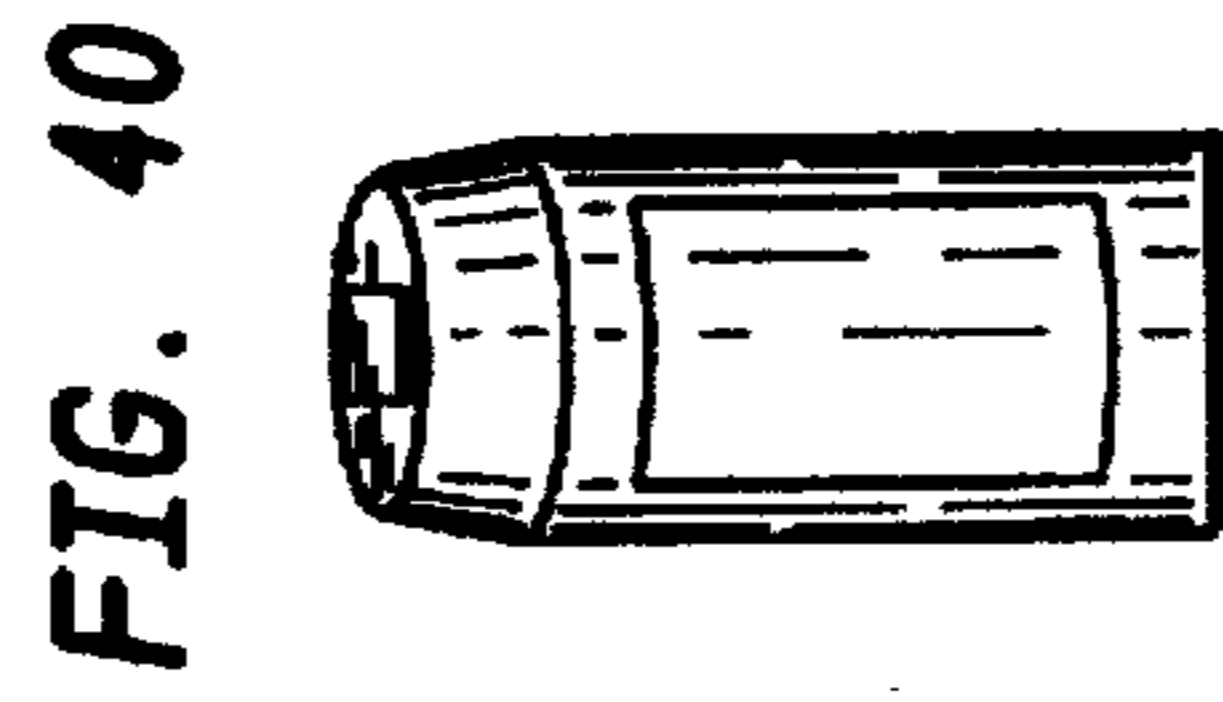
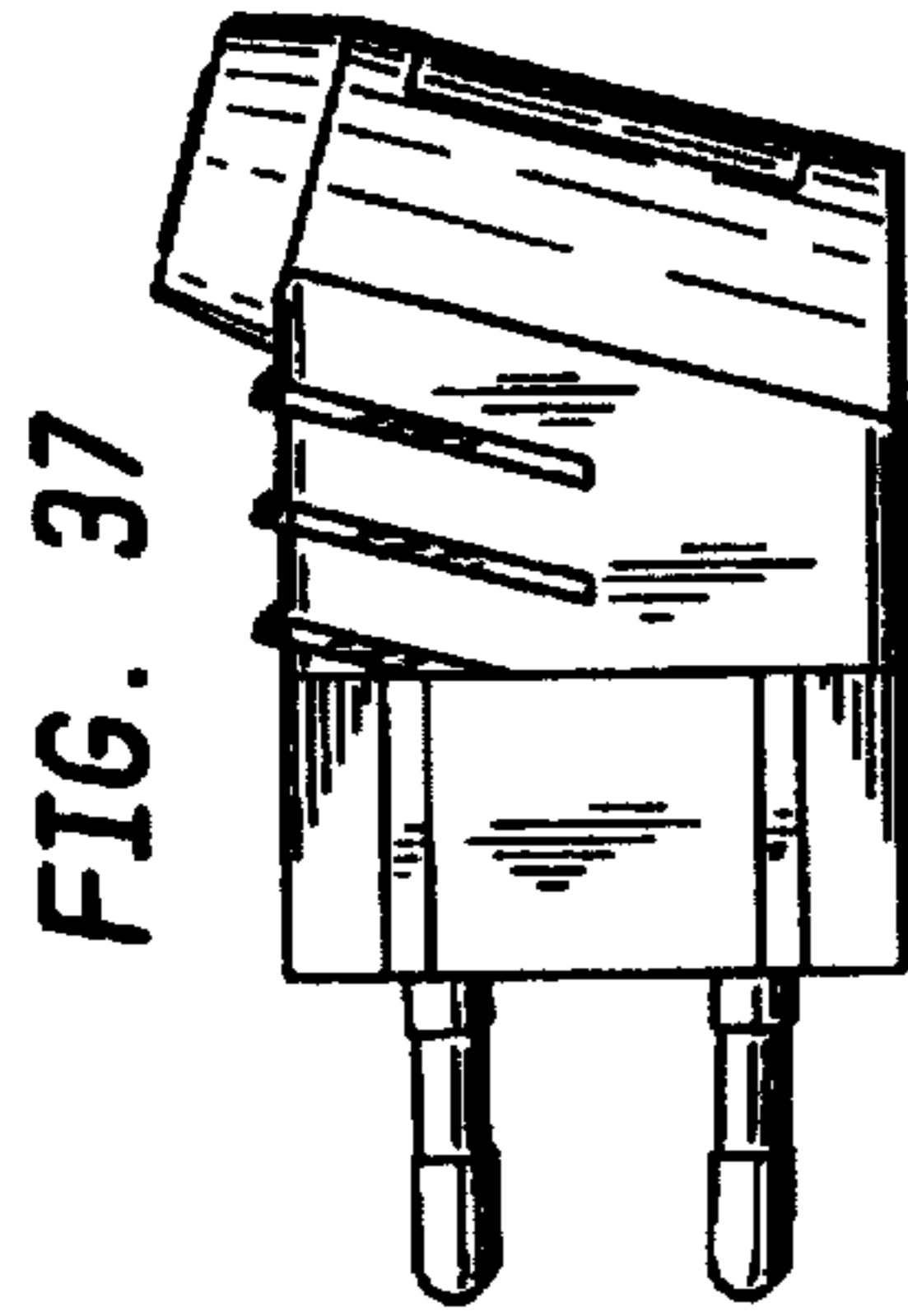

FIG. 44

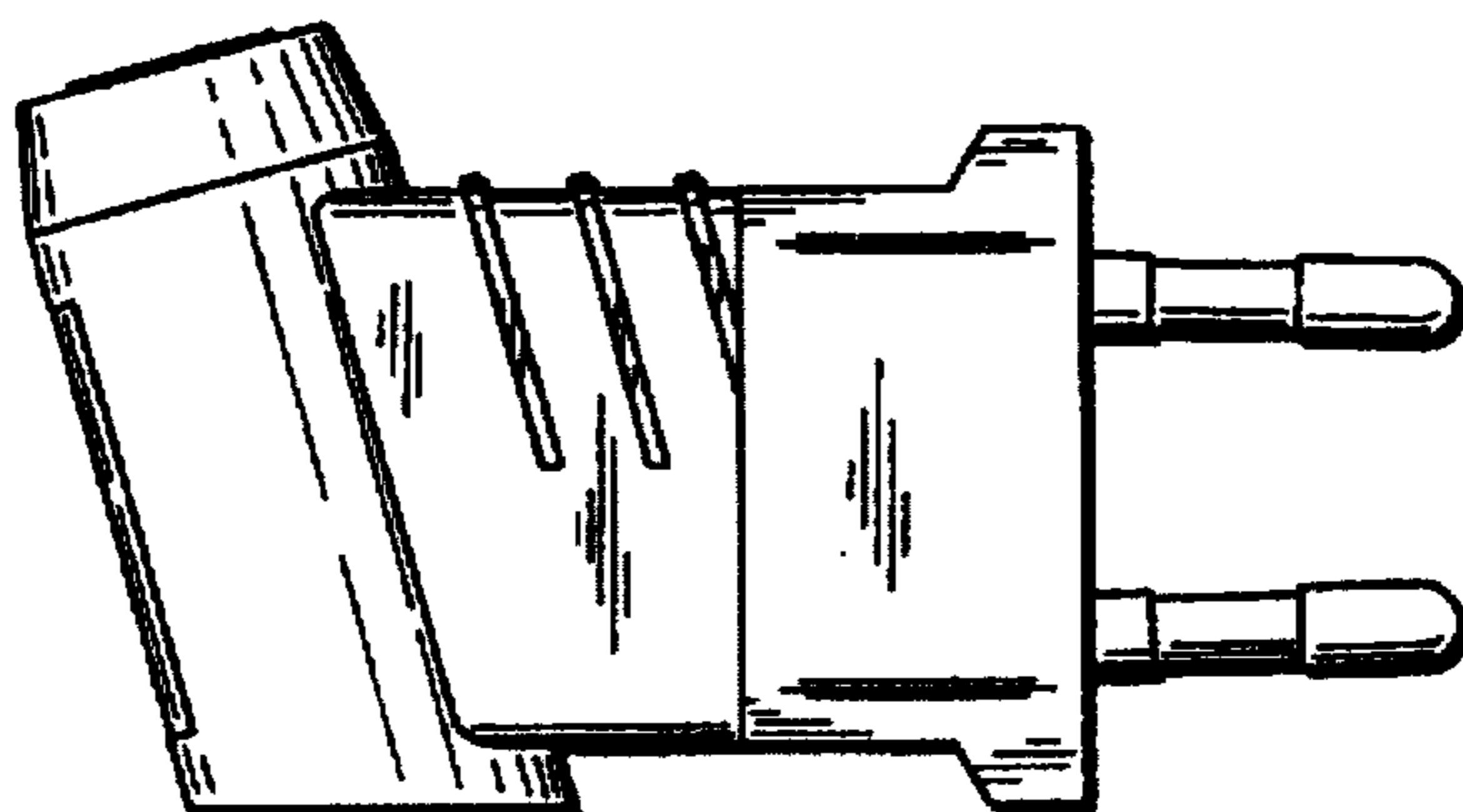

FIG. 45

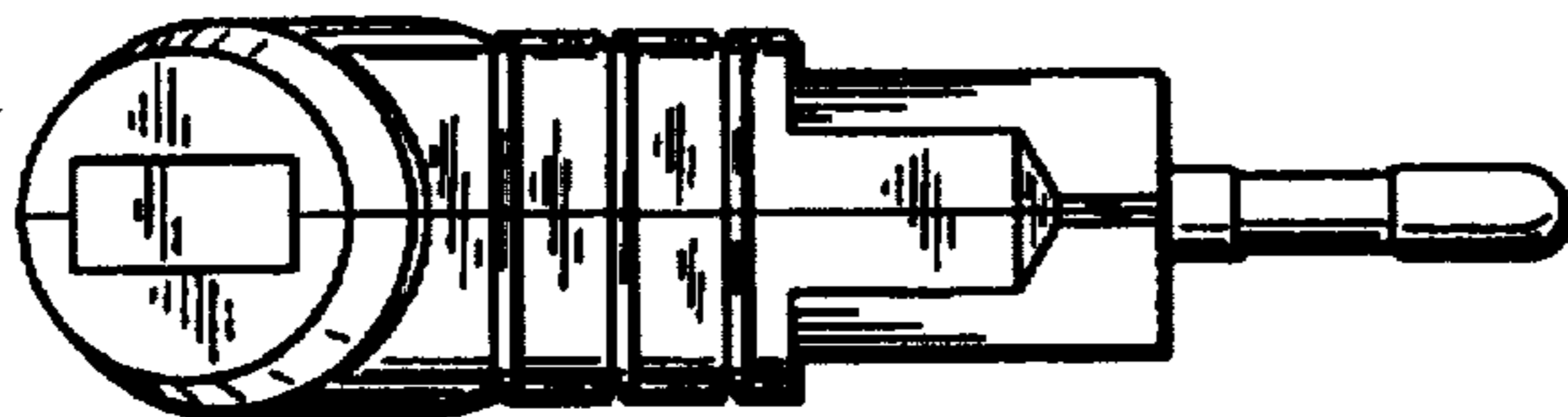

FIG. 46

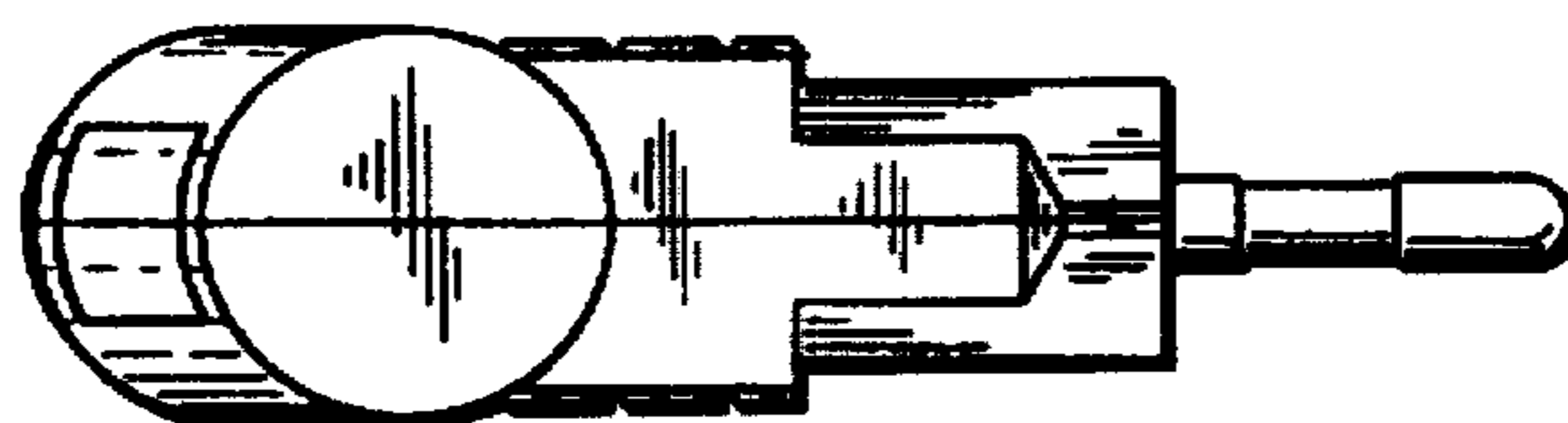

FIG. 47

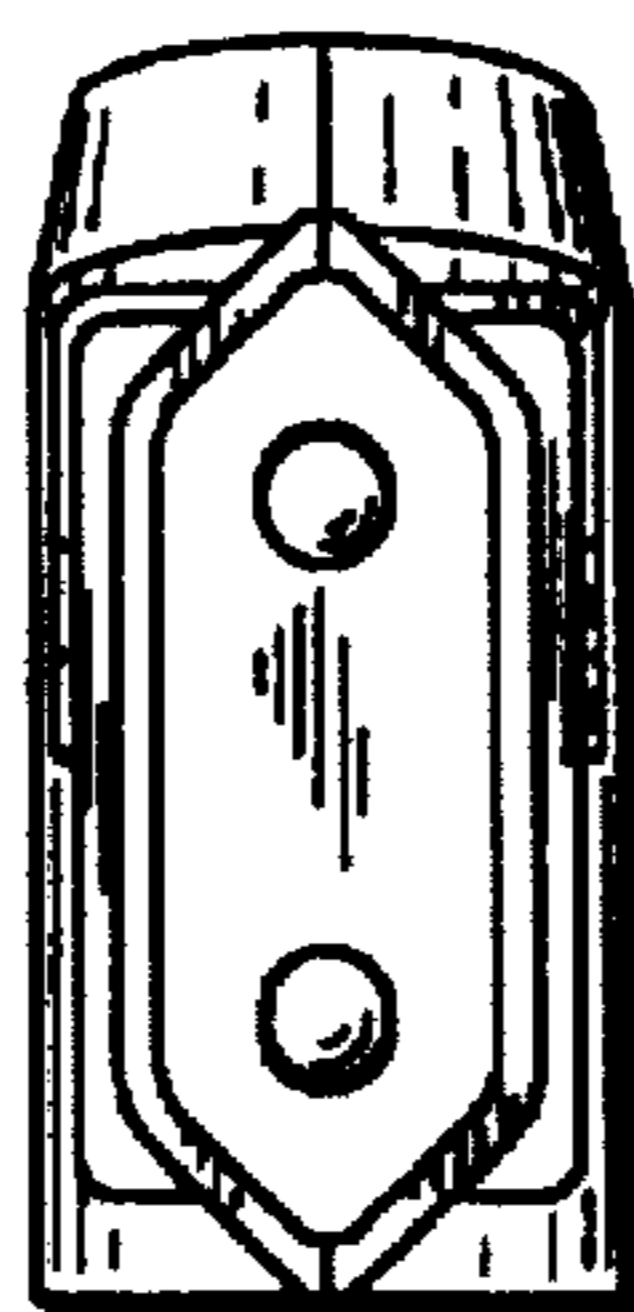

FIG. 48

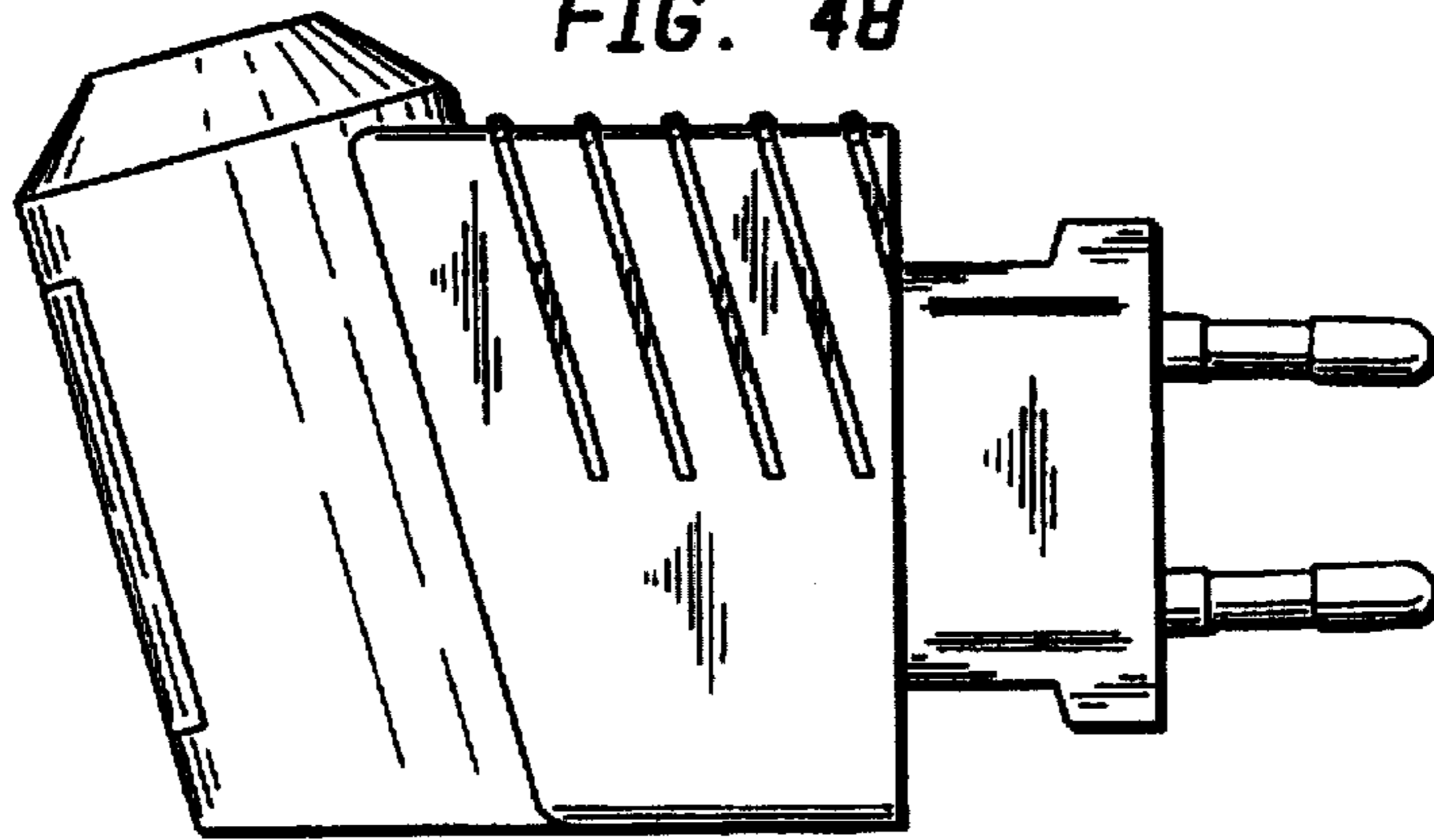

FIG. 49

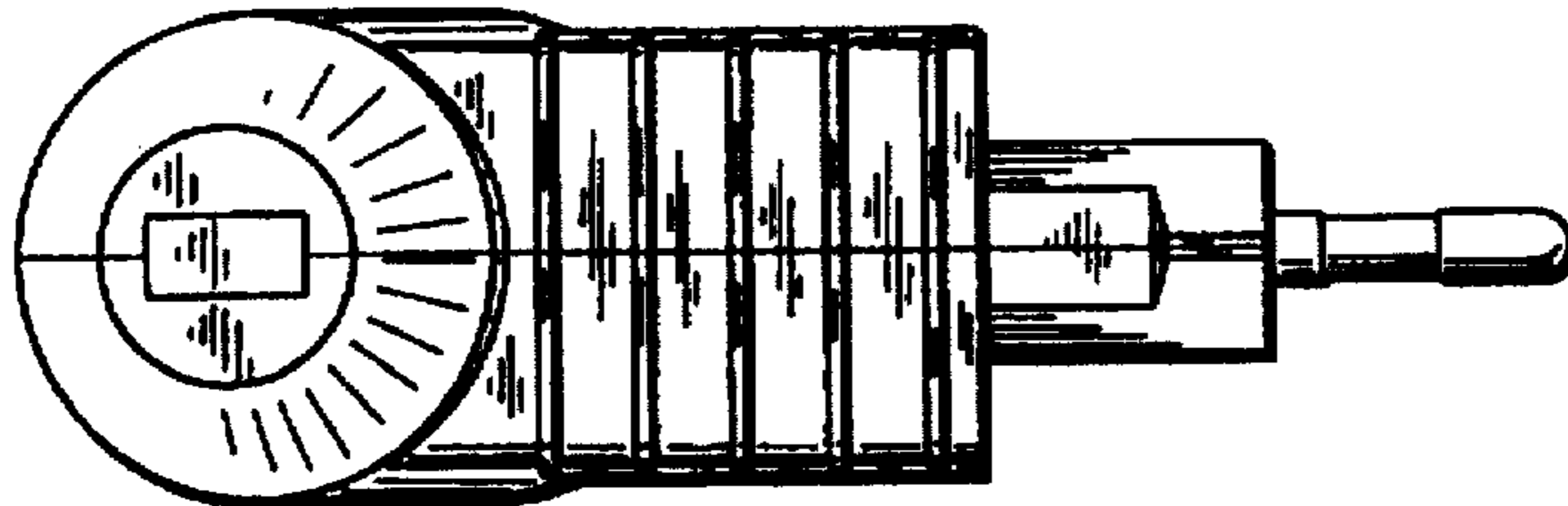

FIG. 50

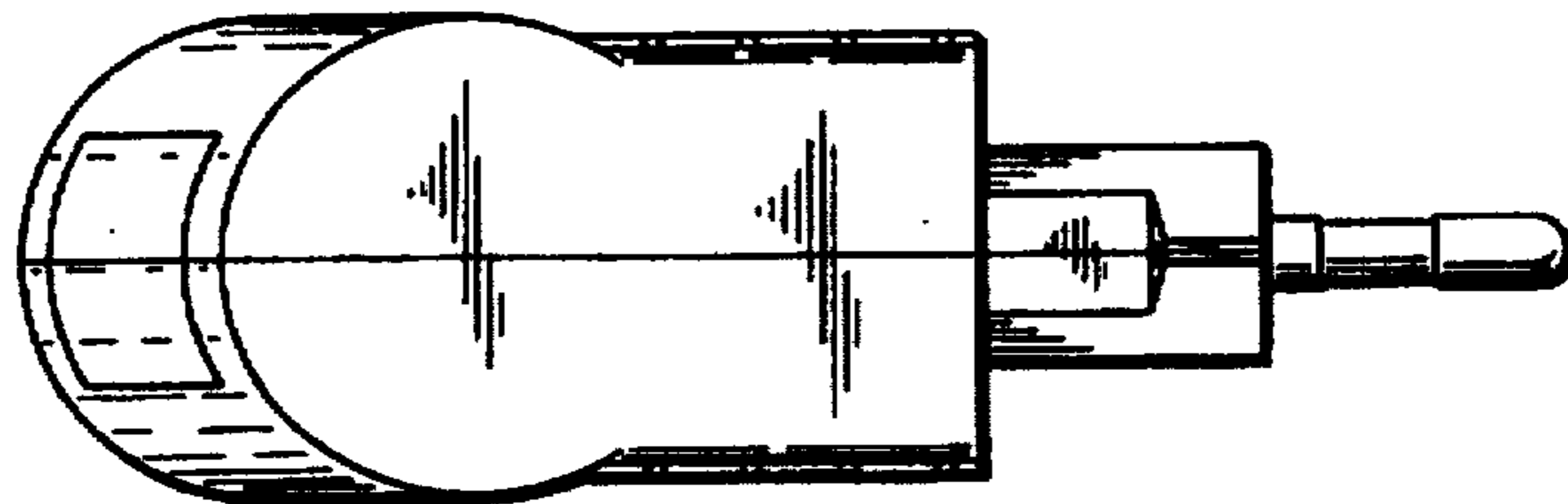

FIG. 51

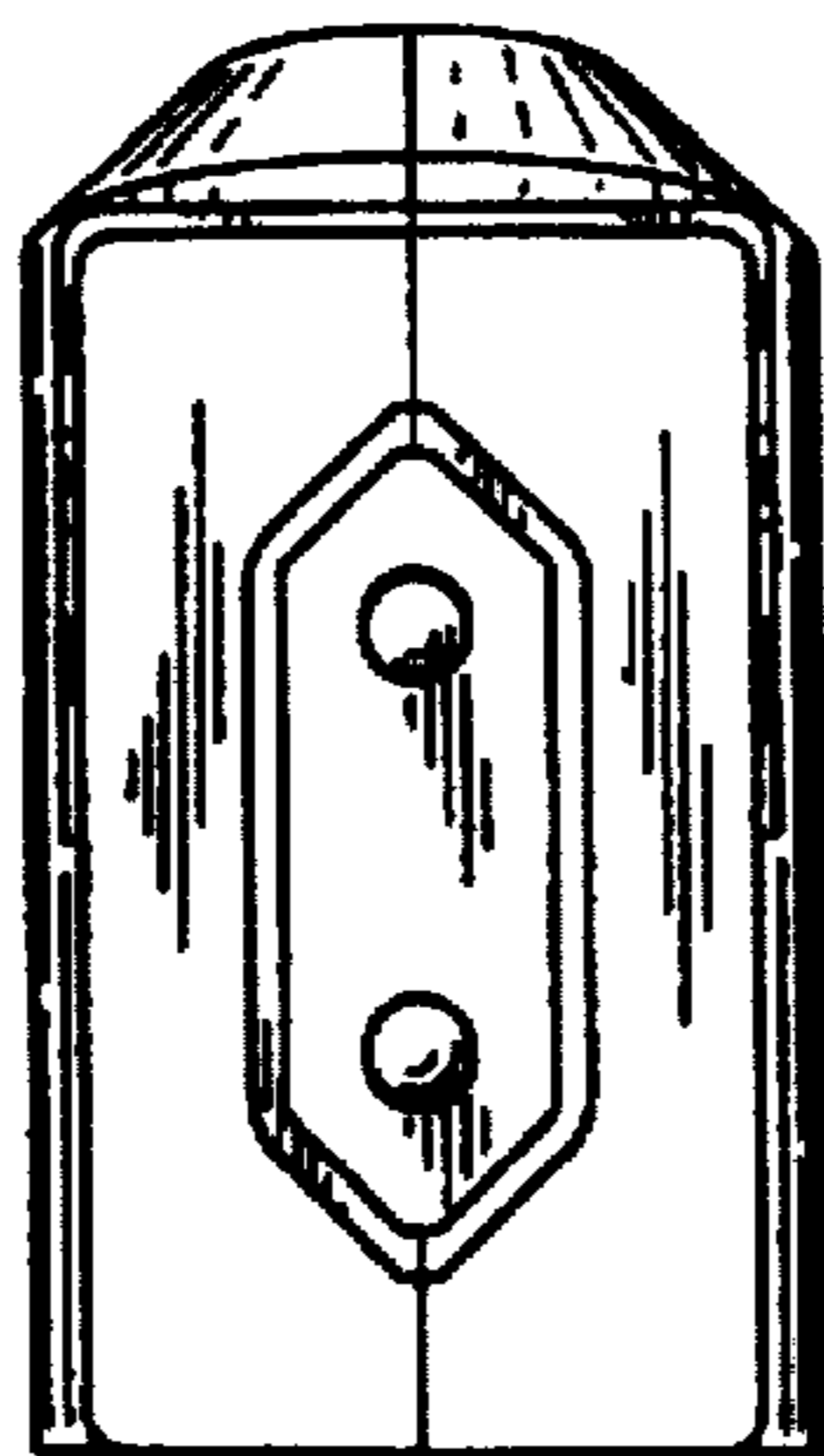

FIG. 52

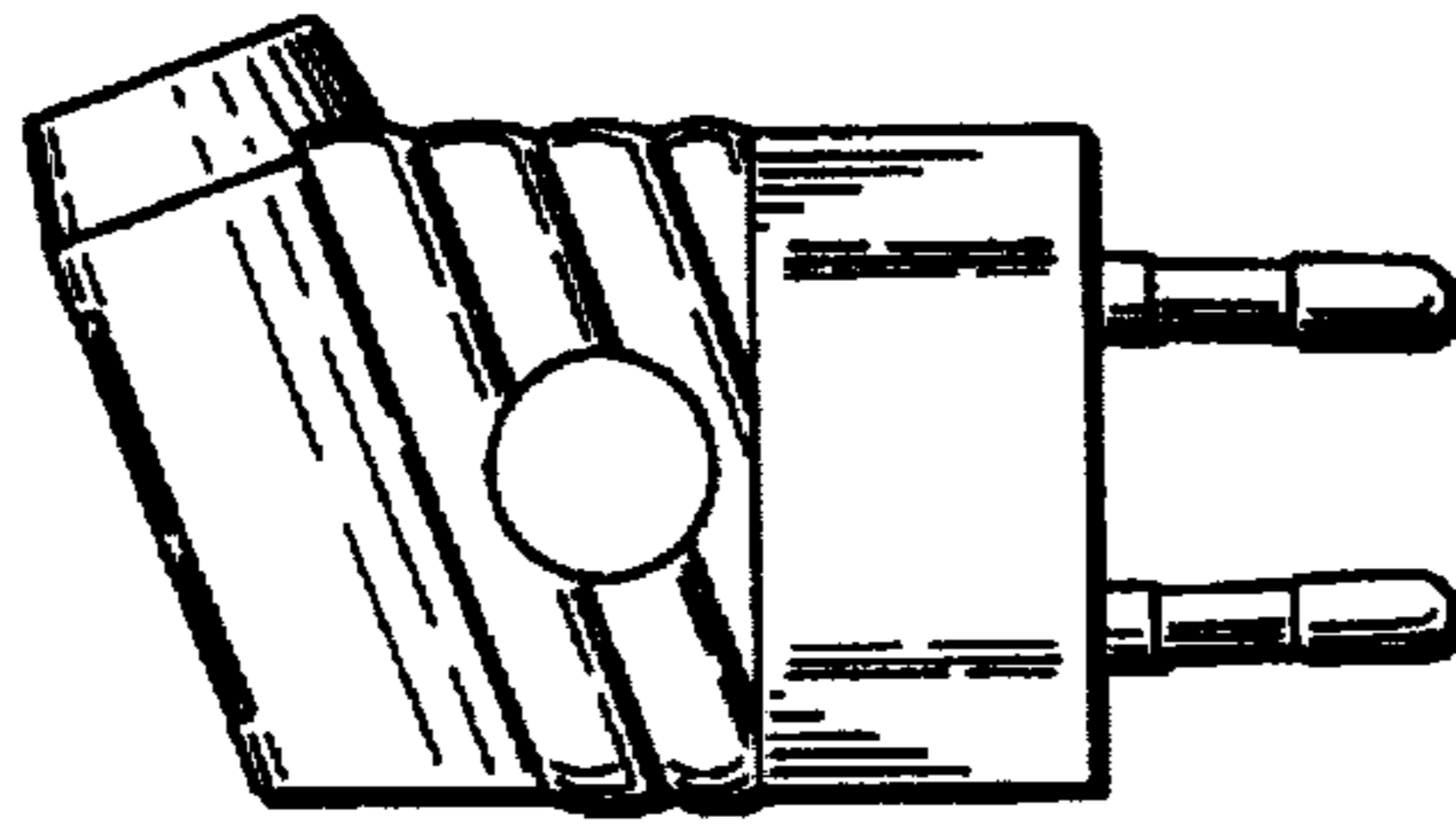

FIG. 53



FIG. 54

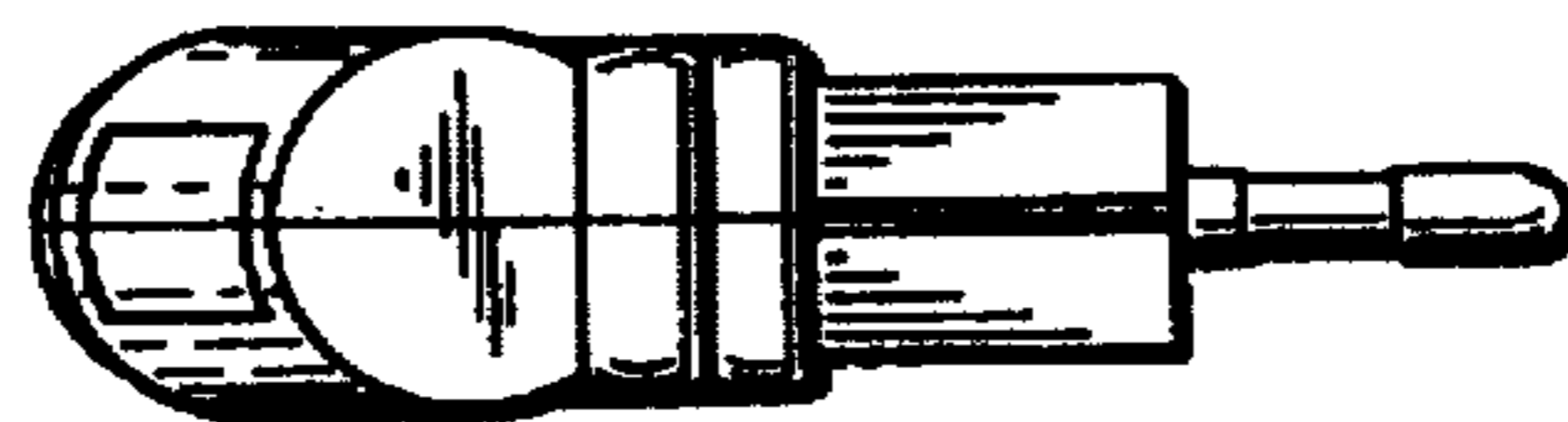

FIG. 55

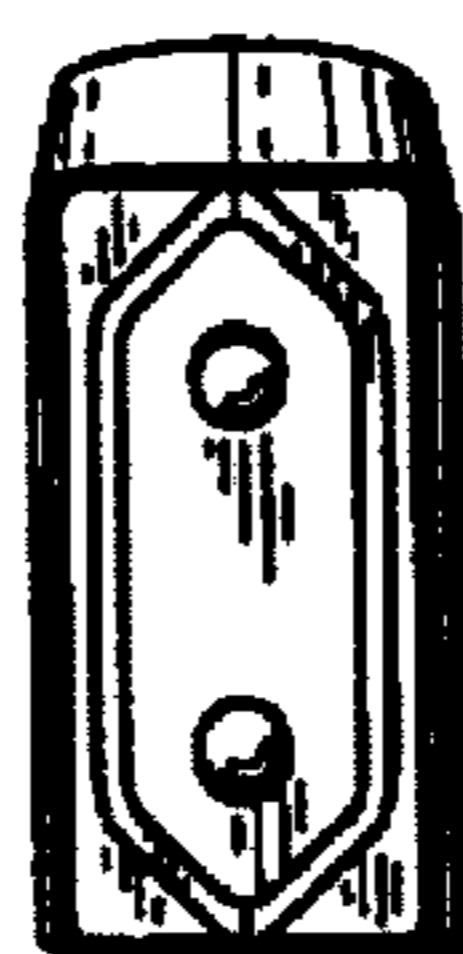

FIG. 56

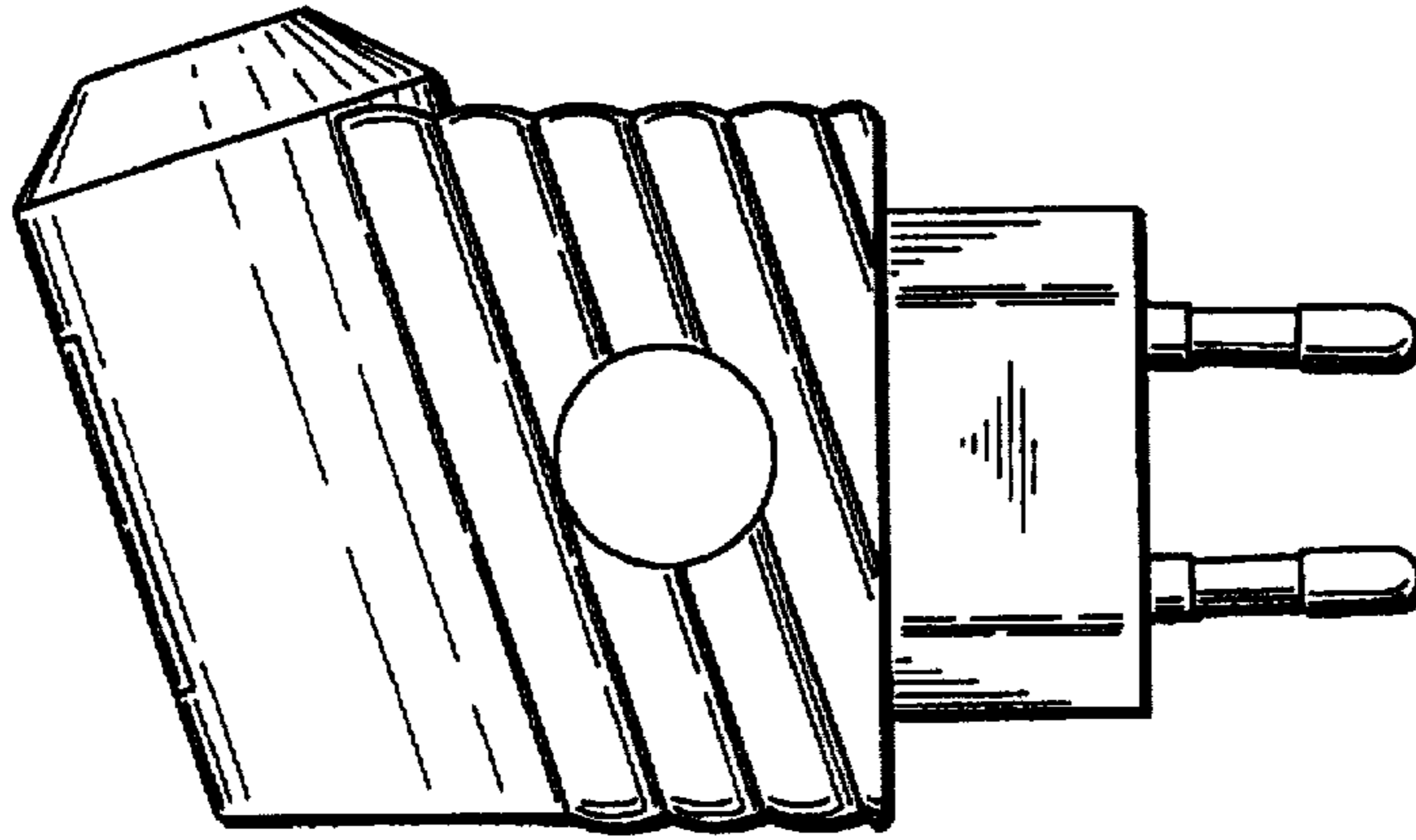

FIG. 57

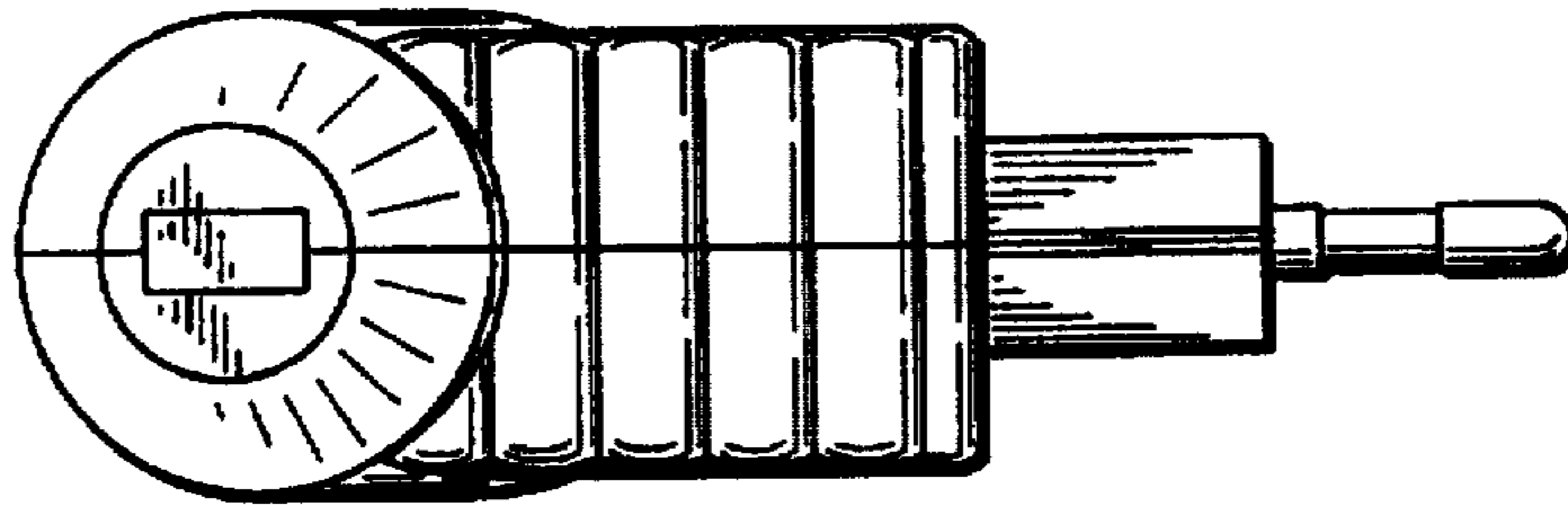

FIG. 58

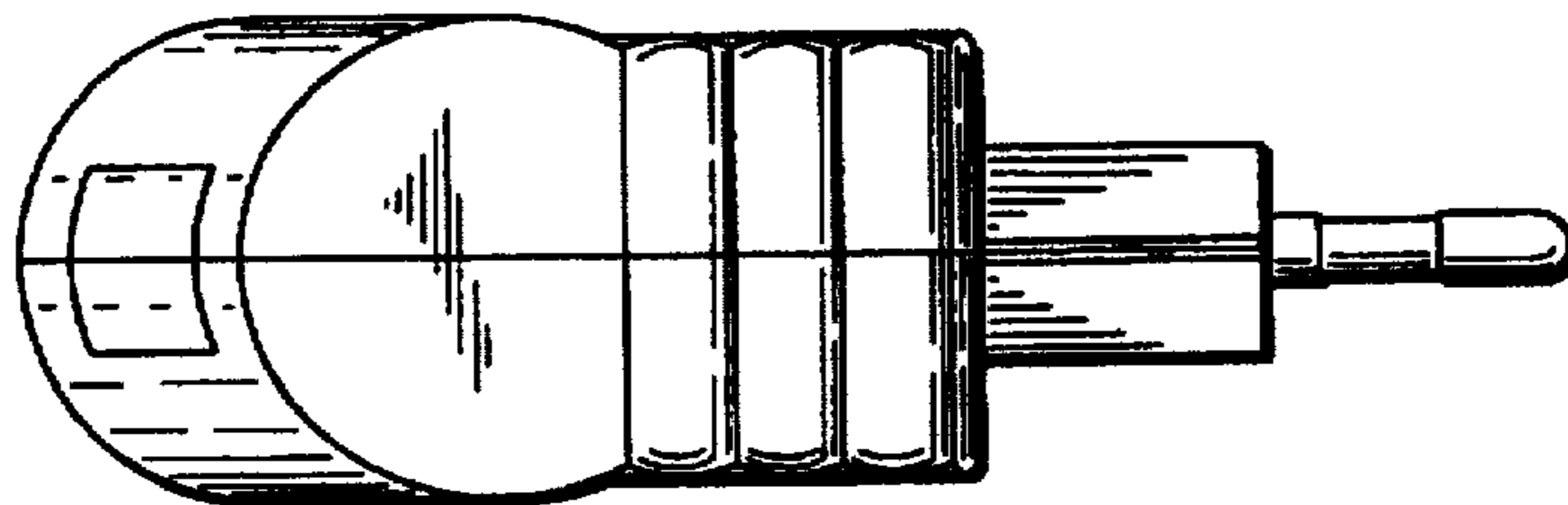

FIG. 59

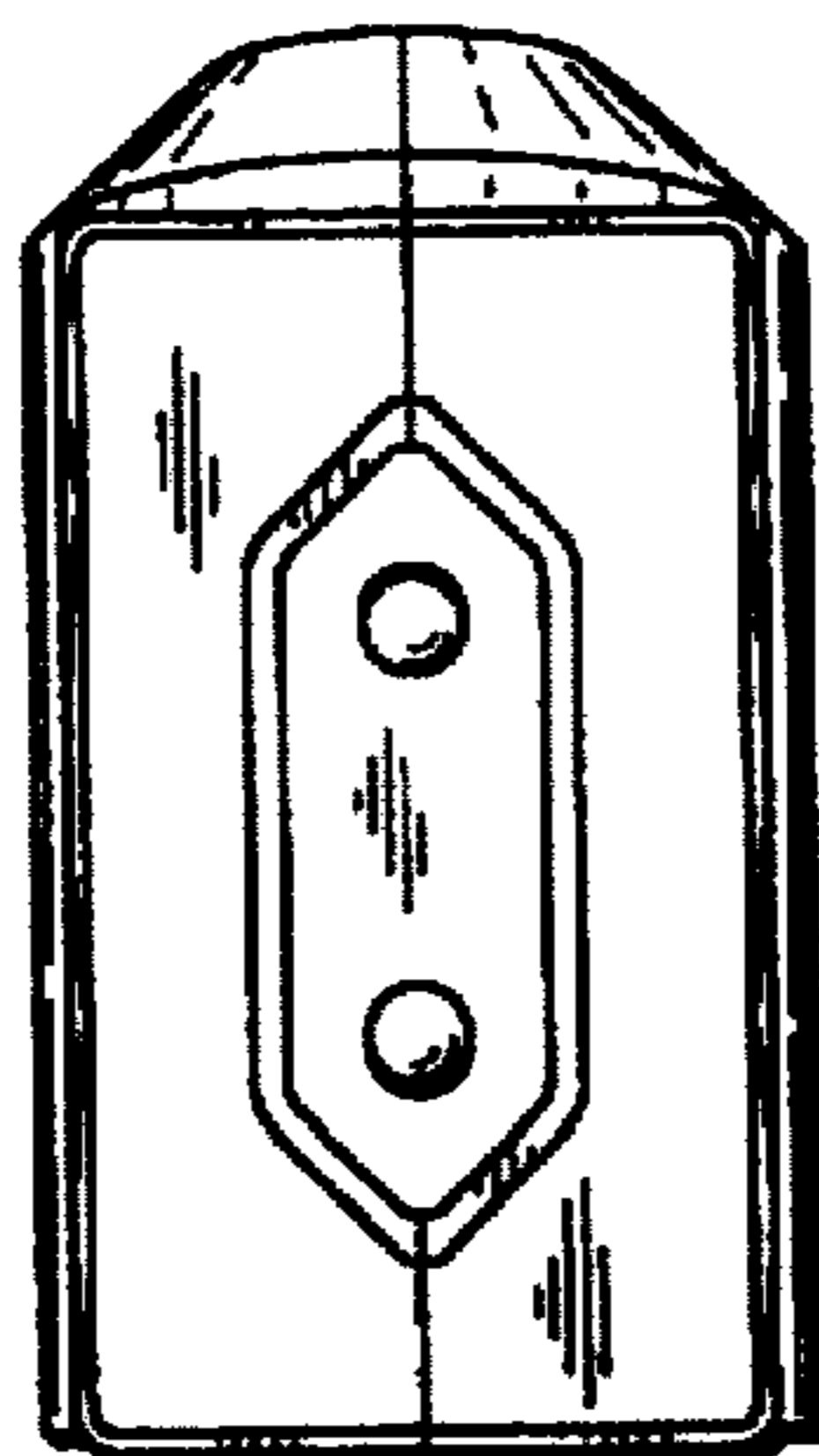

FIG. 60

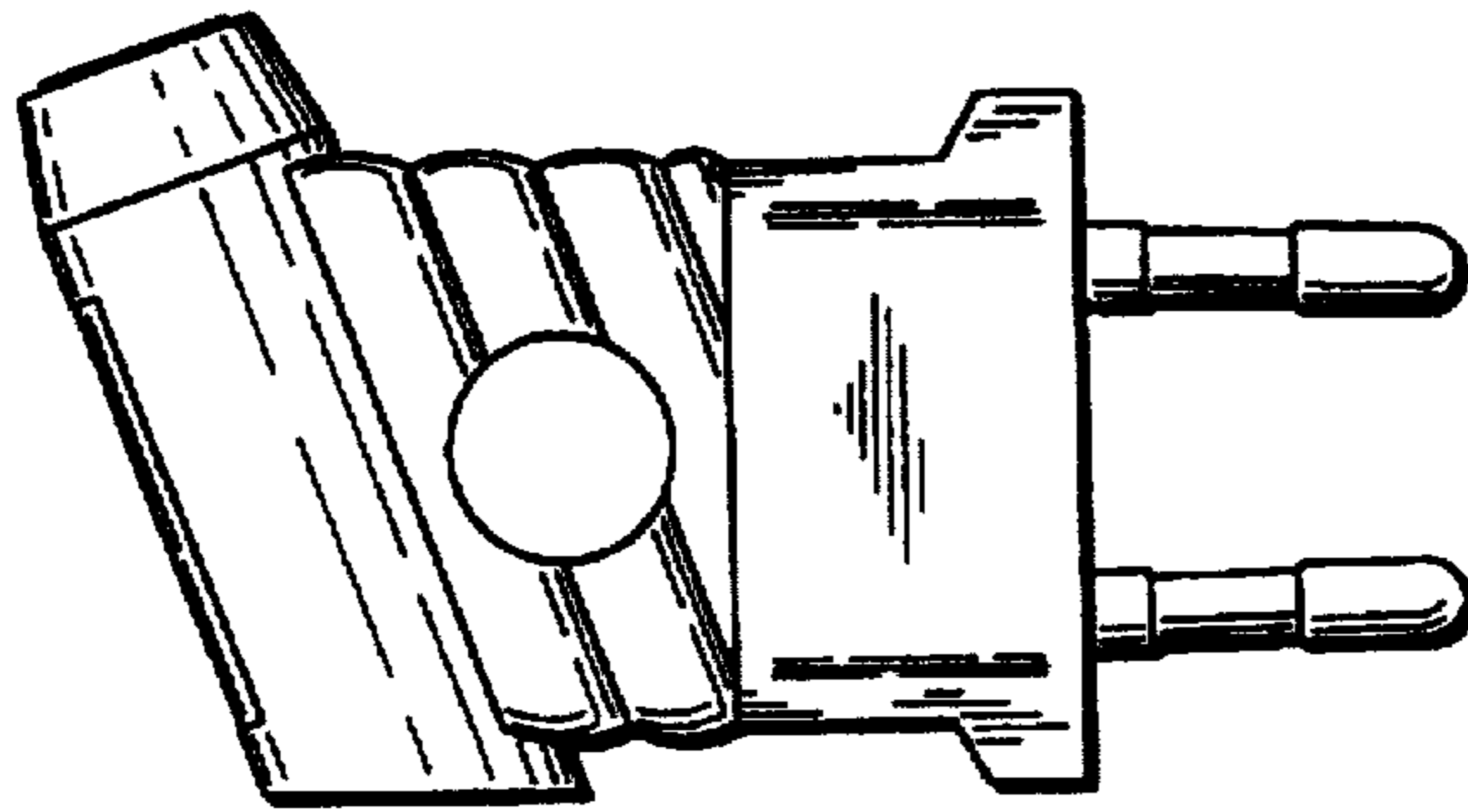

FIG. 61

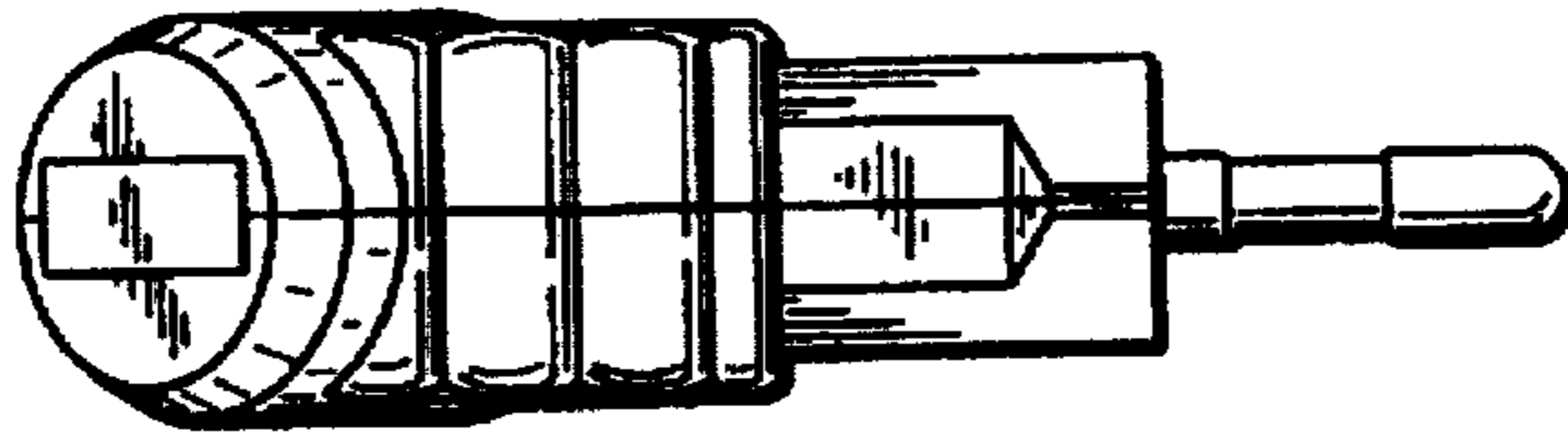

FIG. 62

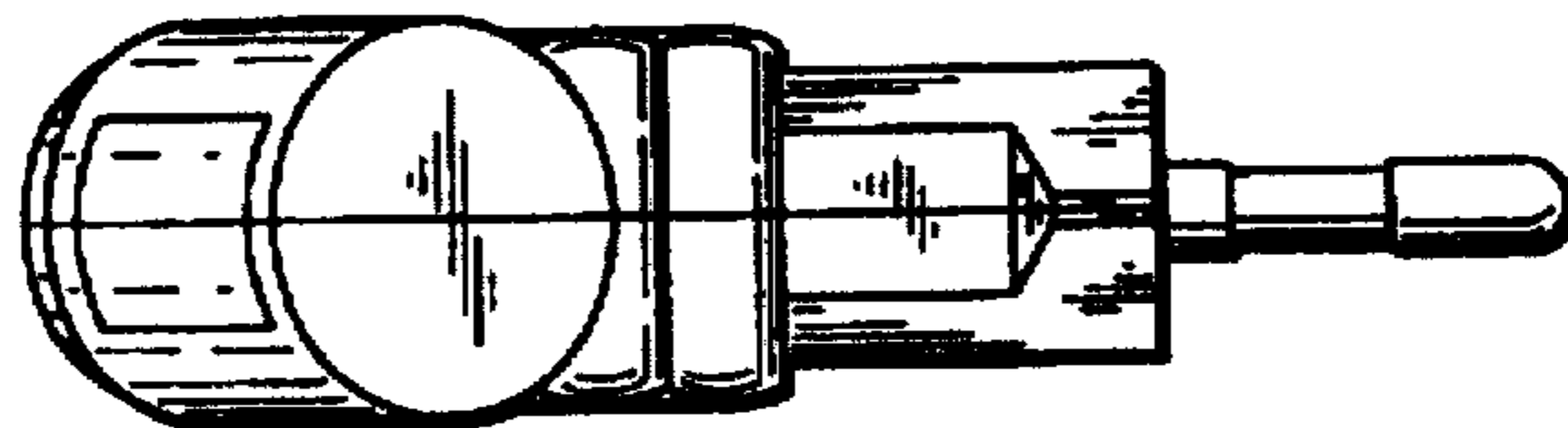

FIG. 63

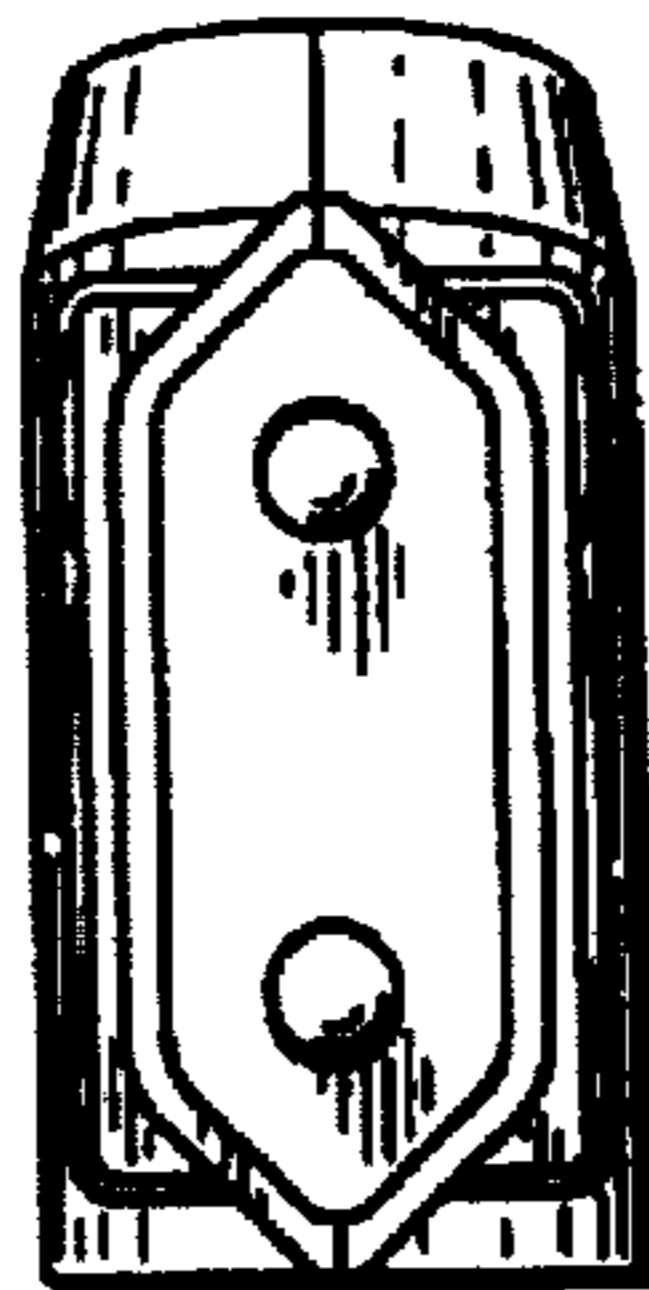

FIG. 64

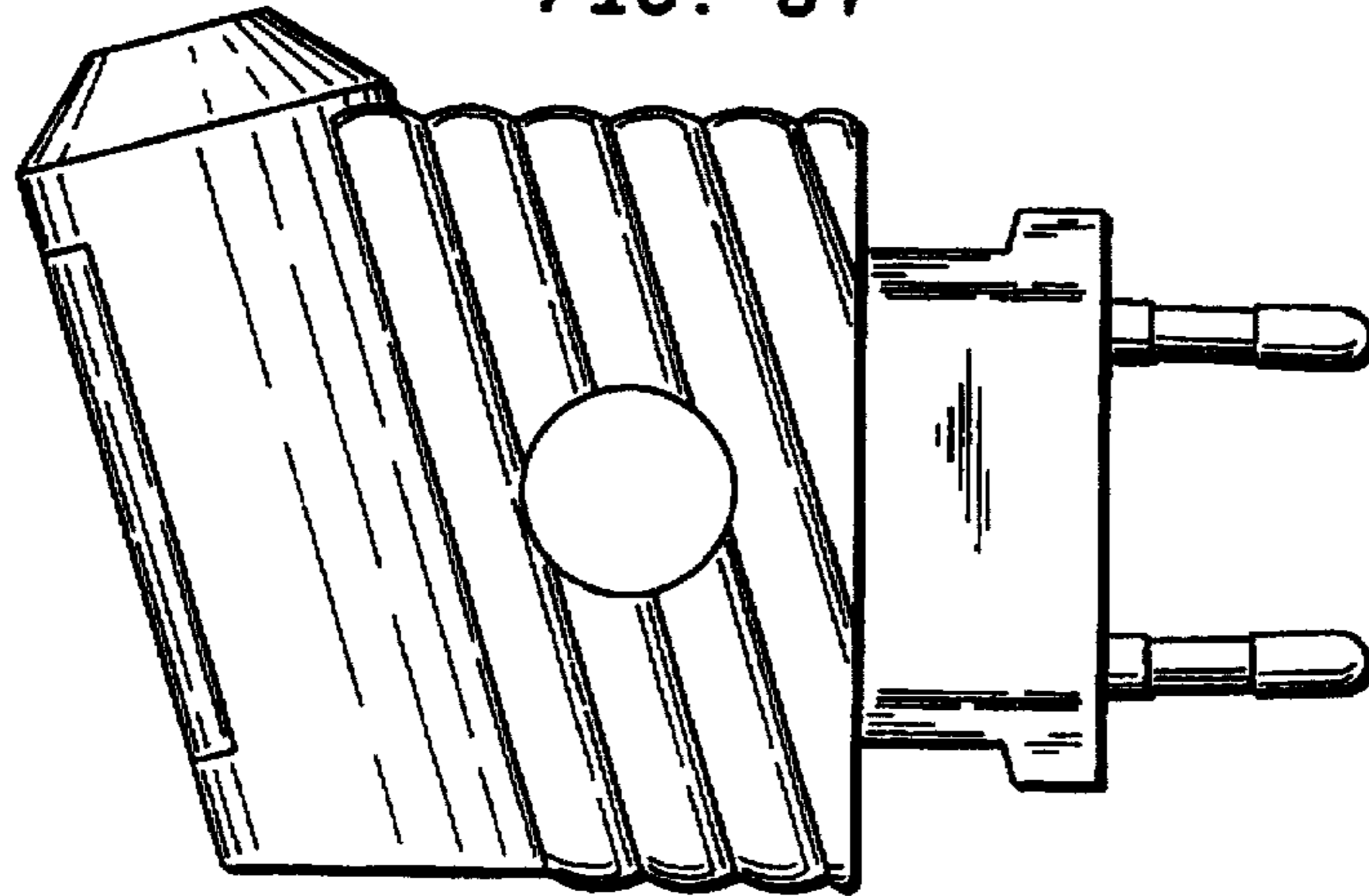

FIG. 65

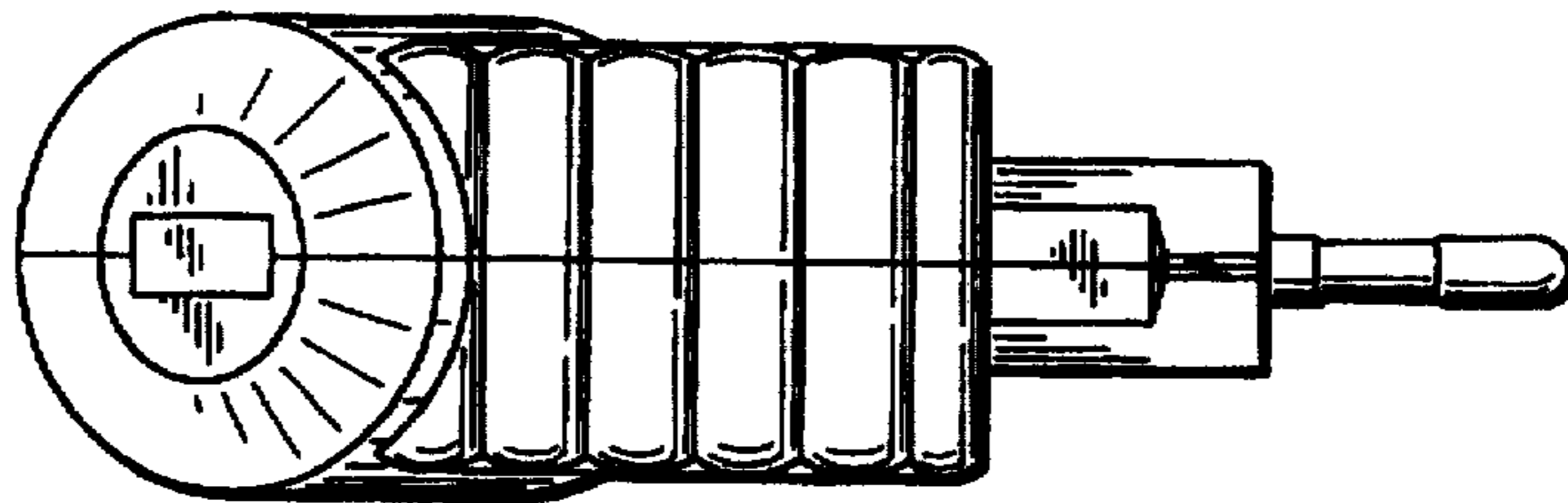

FIG. 66

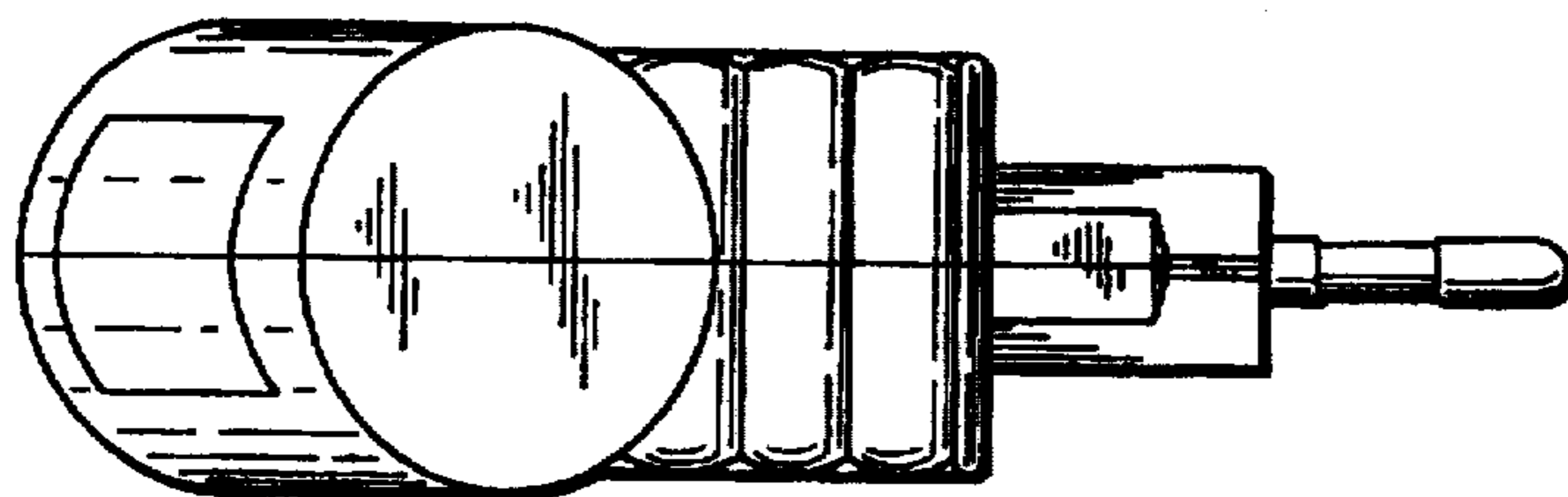

FIG. 67

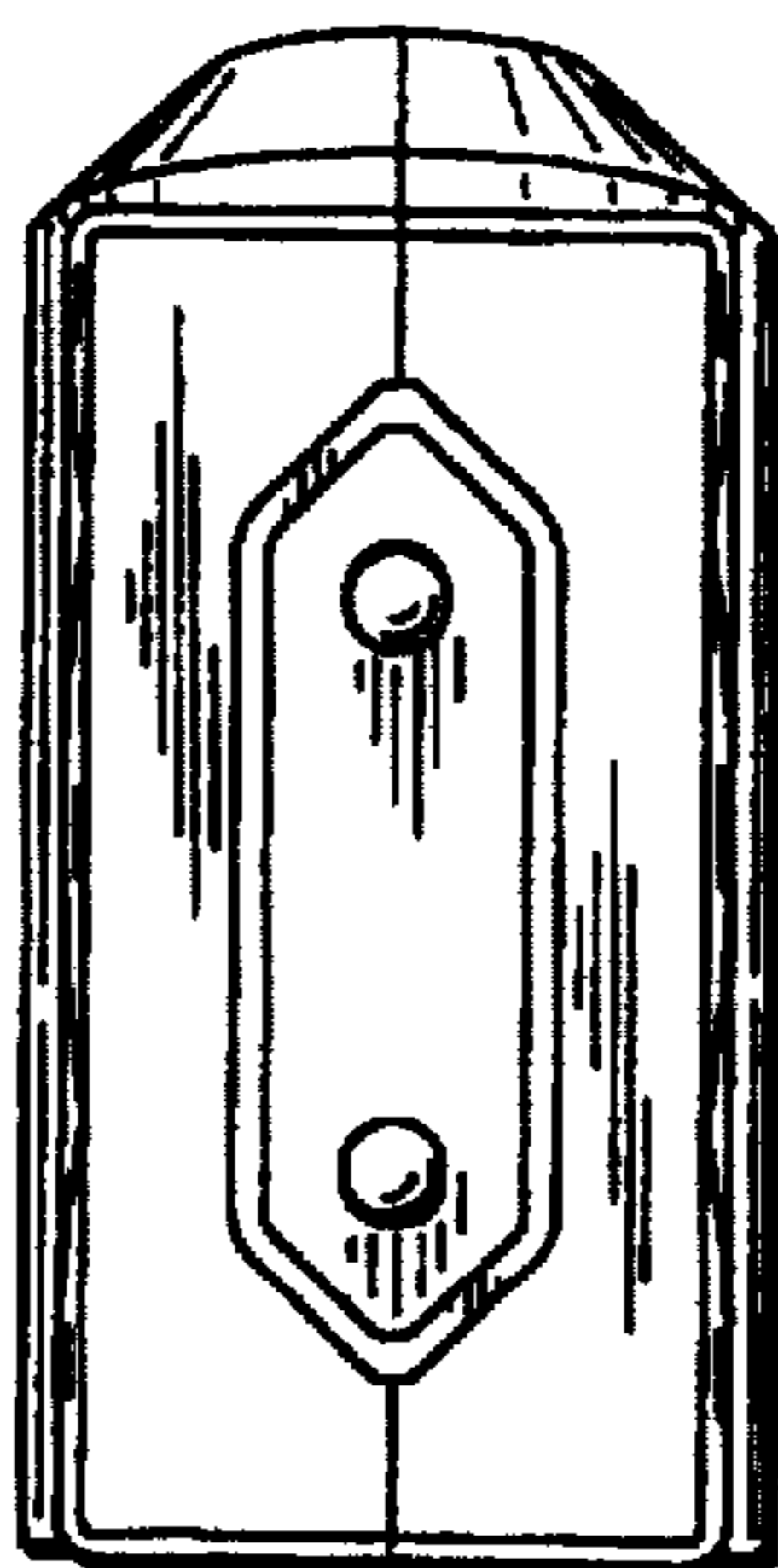

FIG. 68

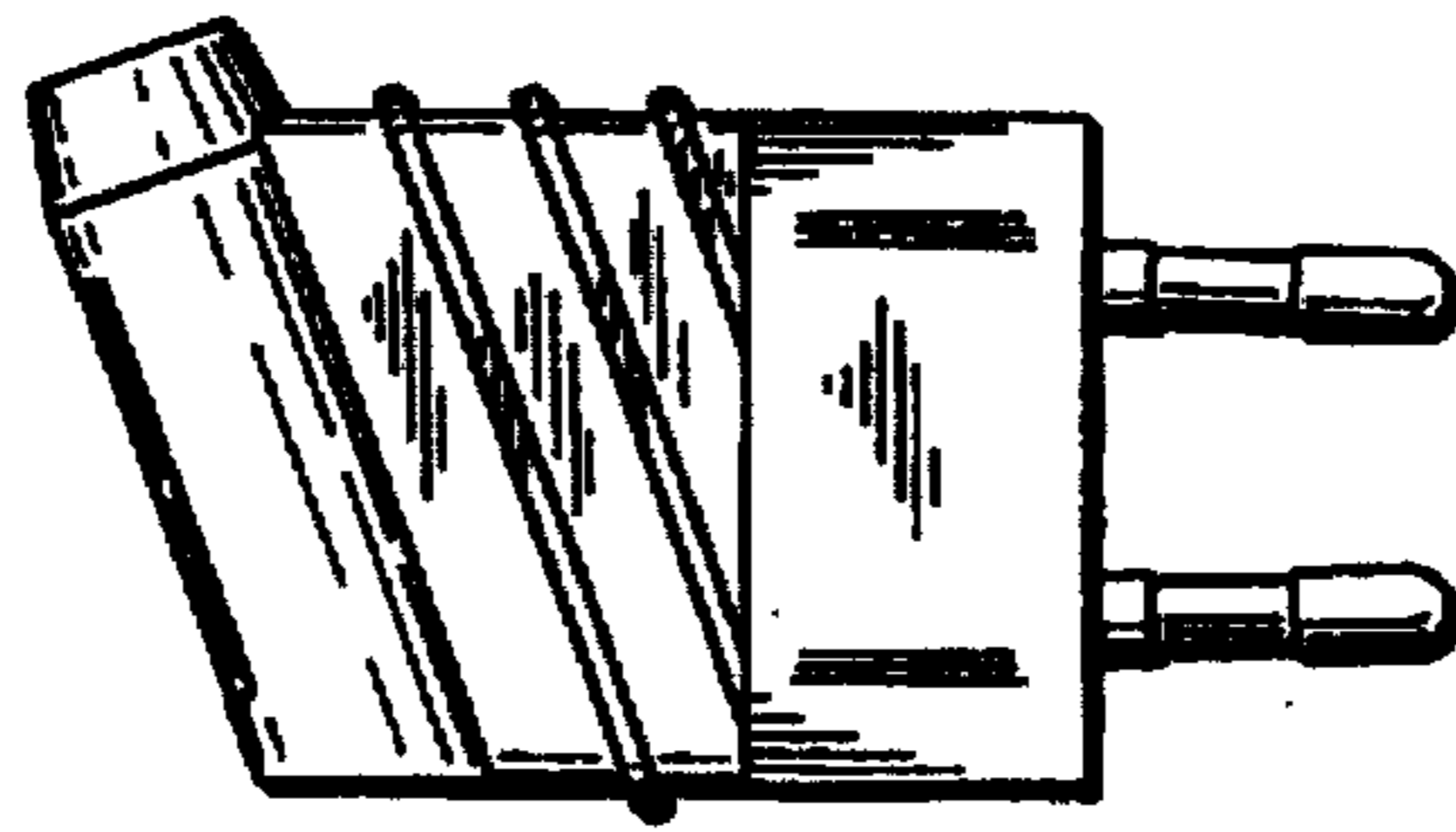

FIG. 69



FIG. 70



FIG. 71



FIG. 72

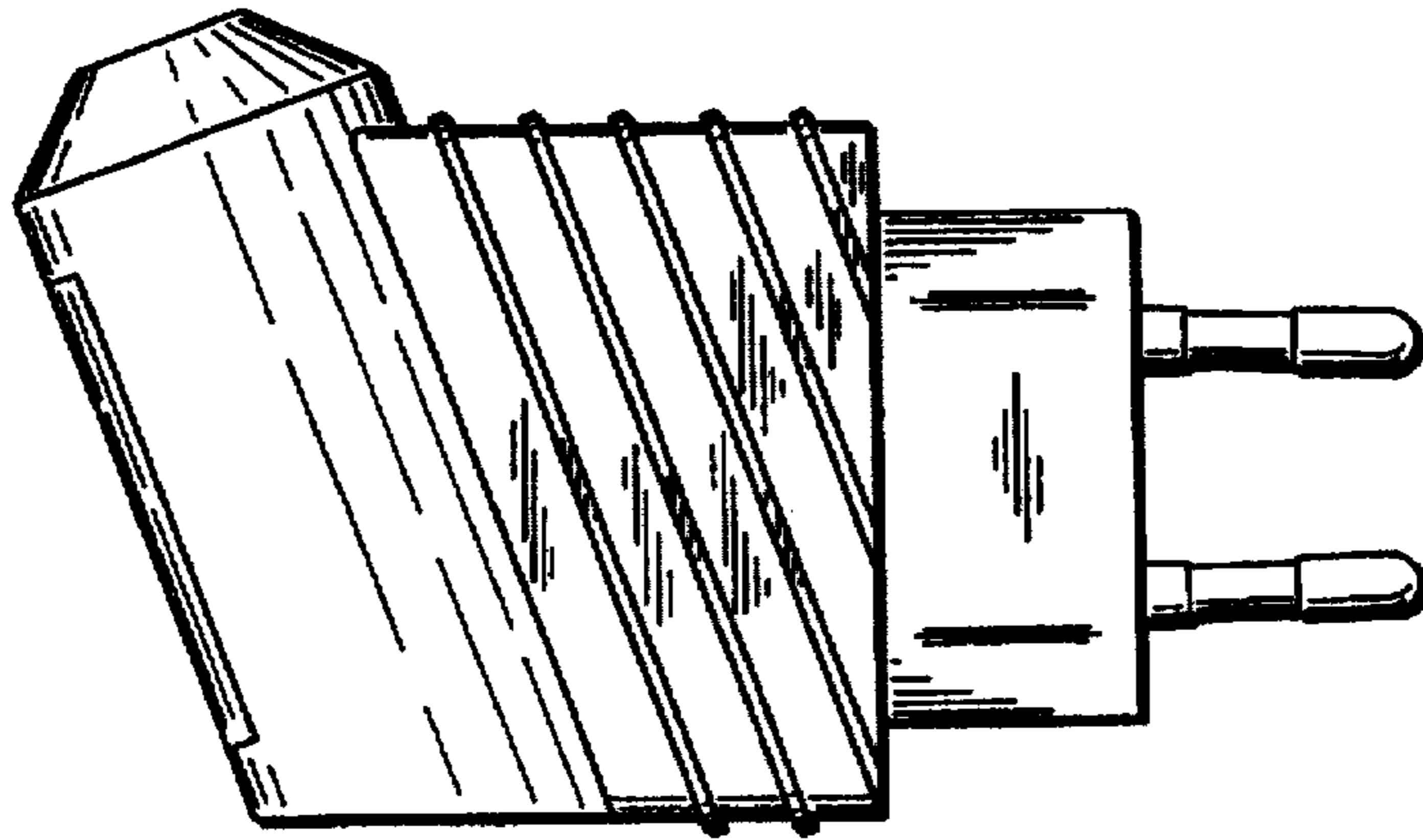

FIG. 73

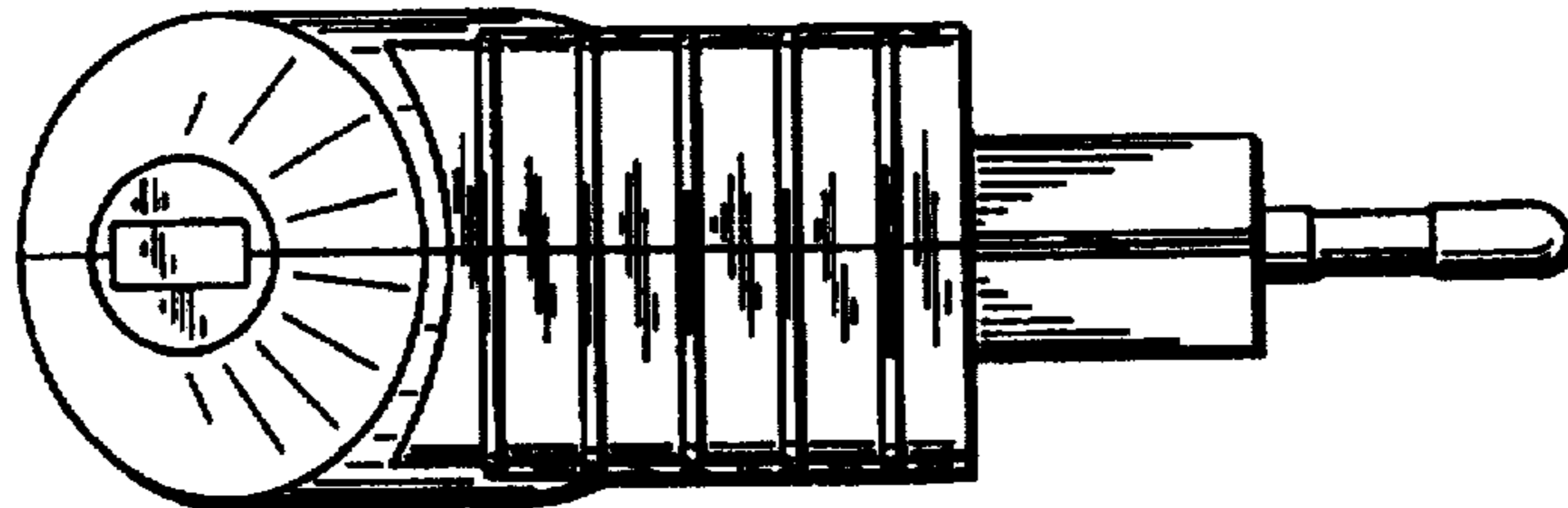

FIG. 74

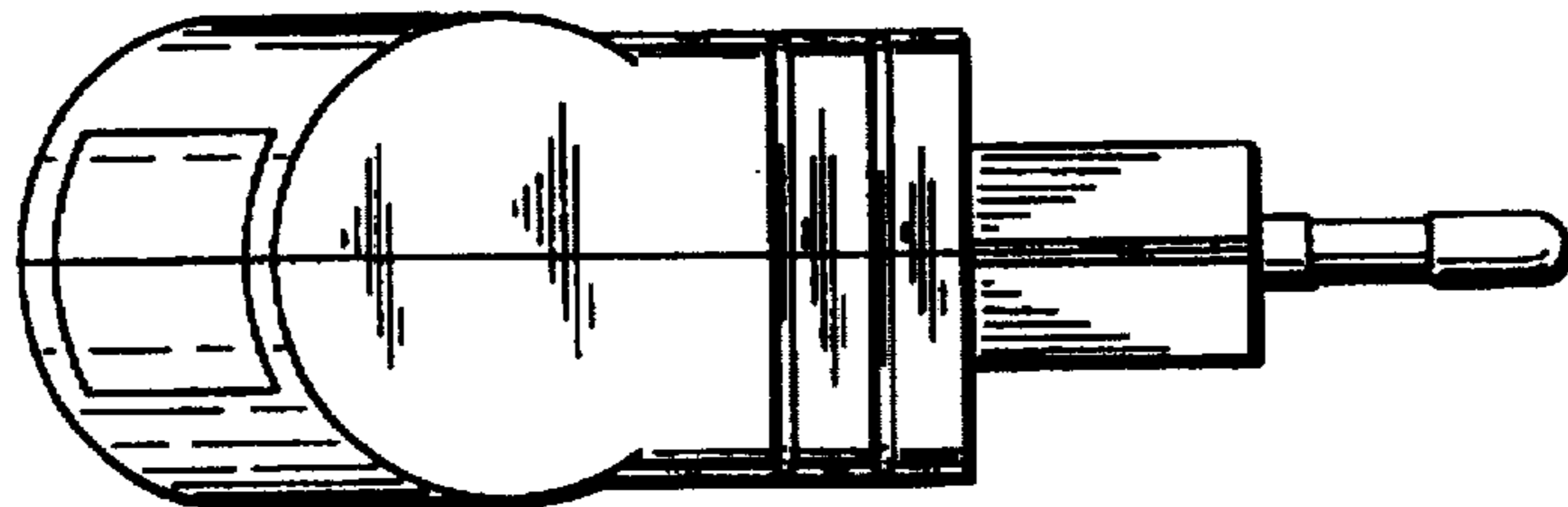

FIG. 75

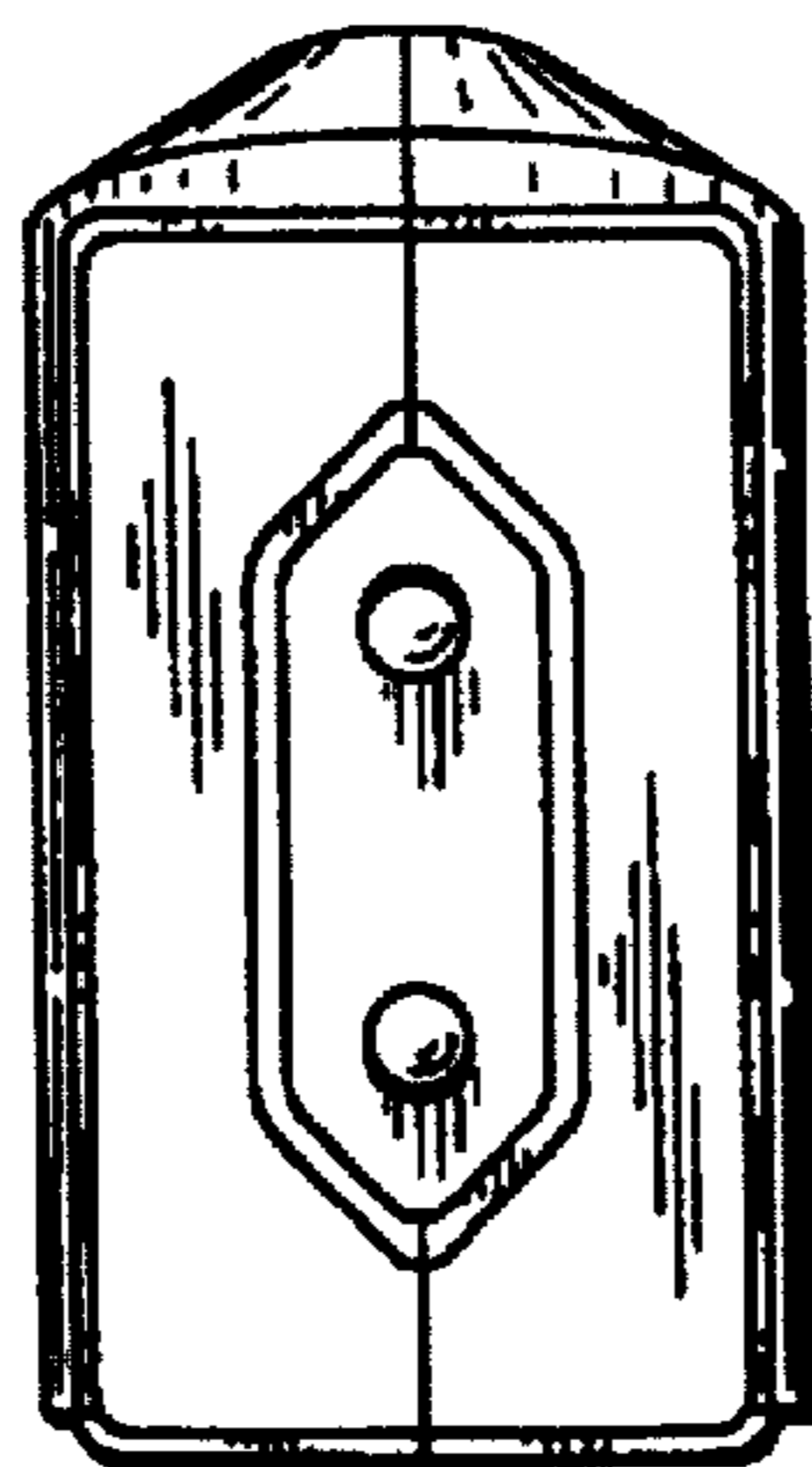

FIG. 76

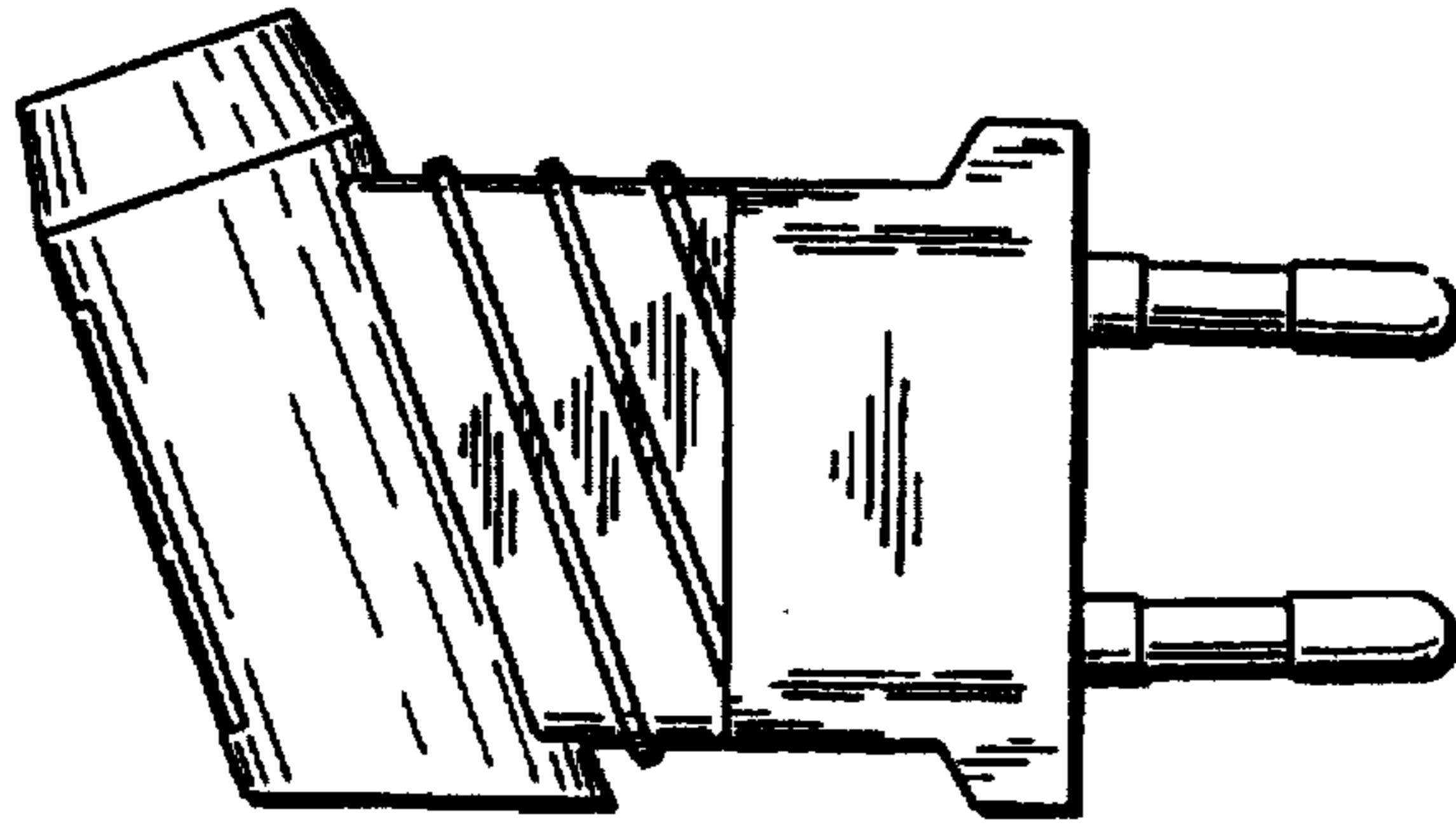

FIG. 77

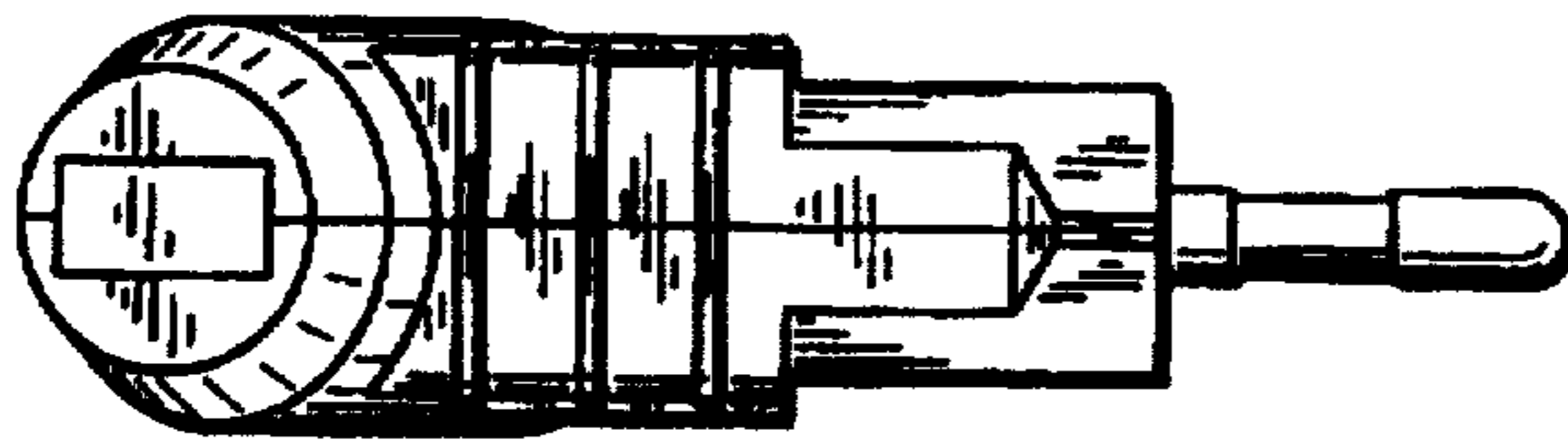

FIG. 78

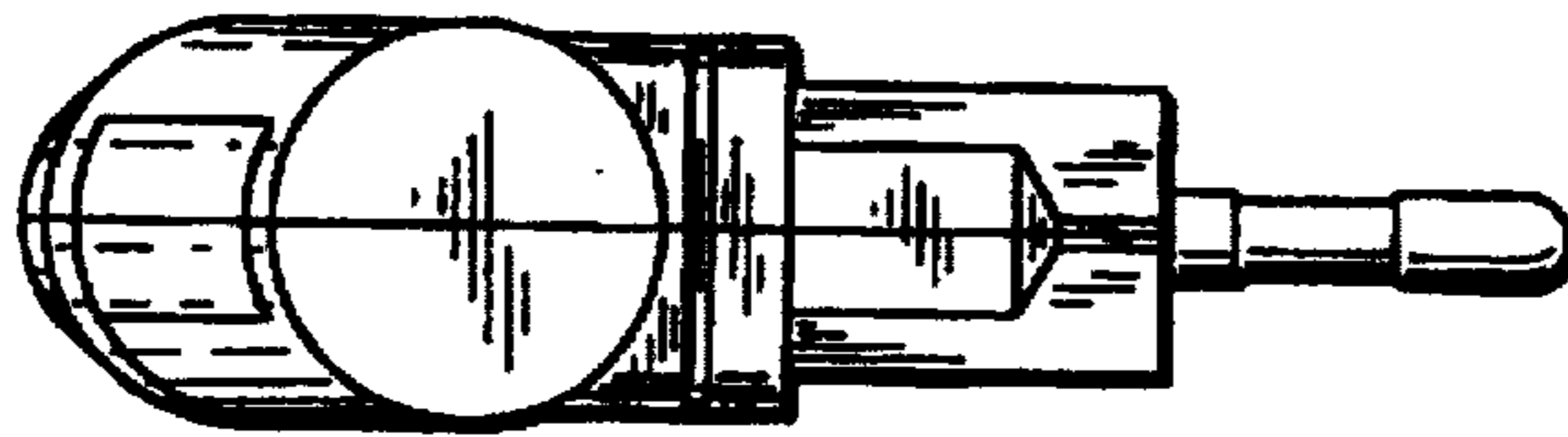

FIG. 79

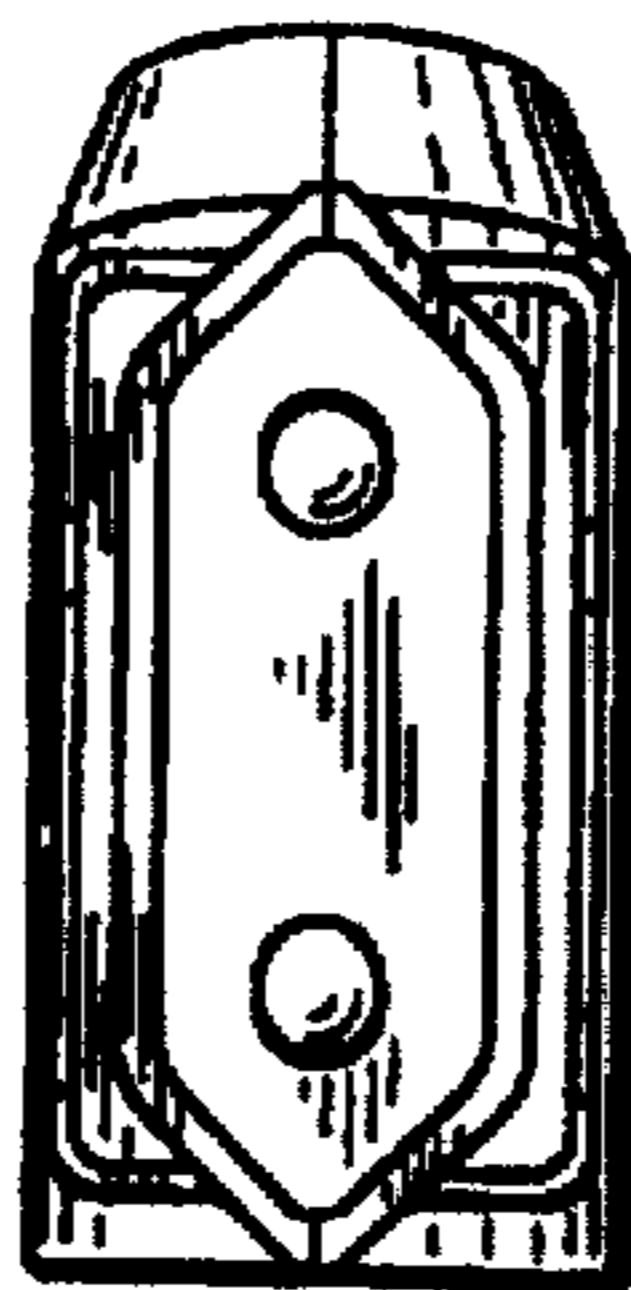

FIG. 80

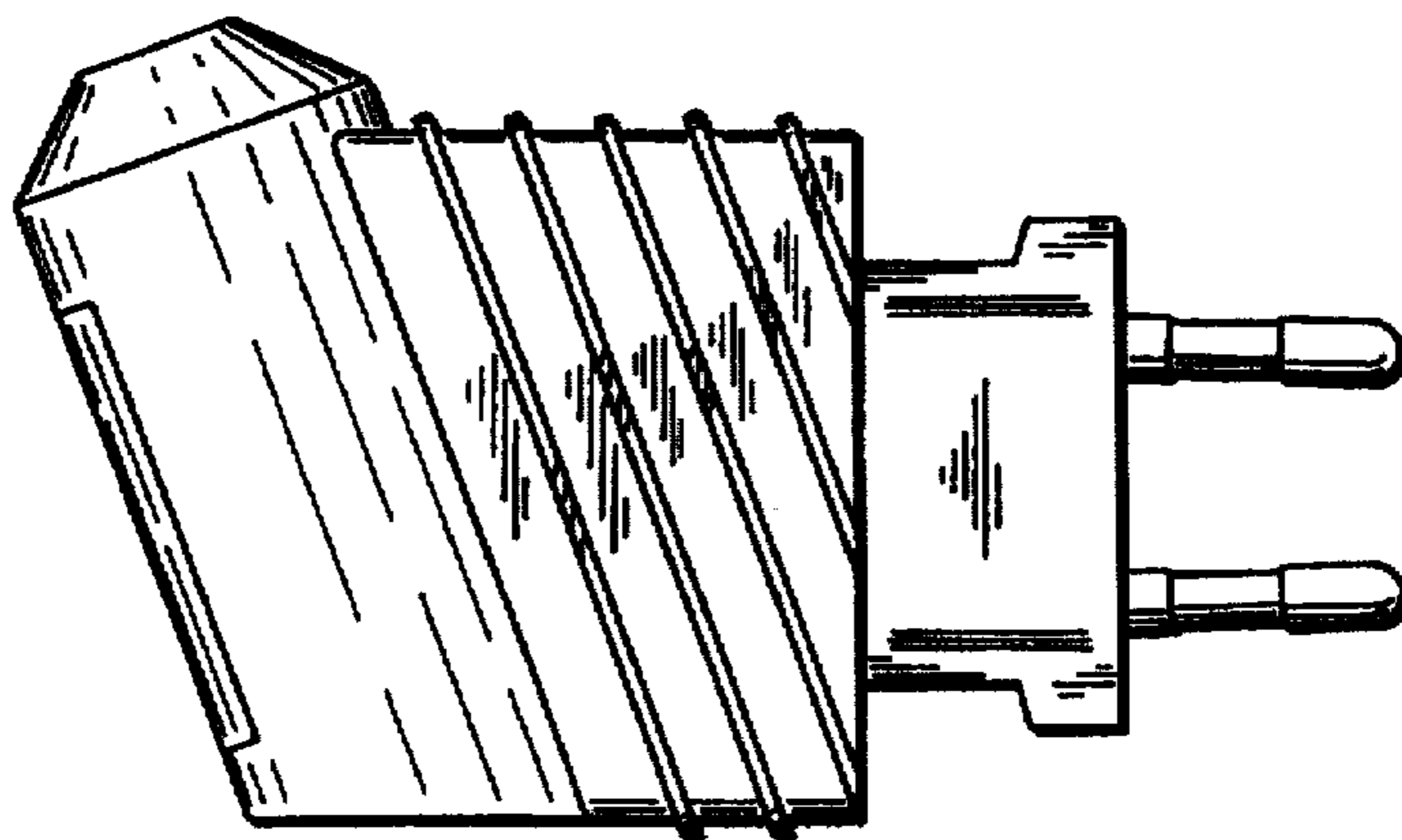

FIG. 81

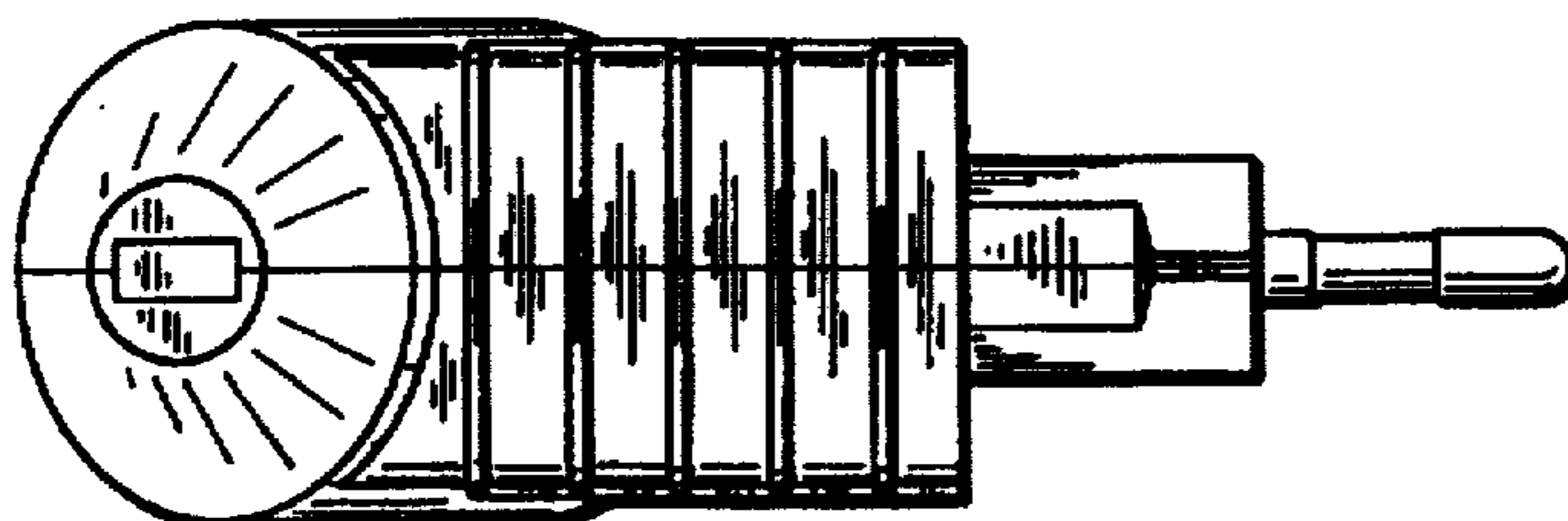

FIG. 82

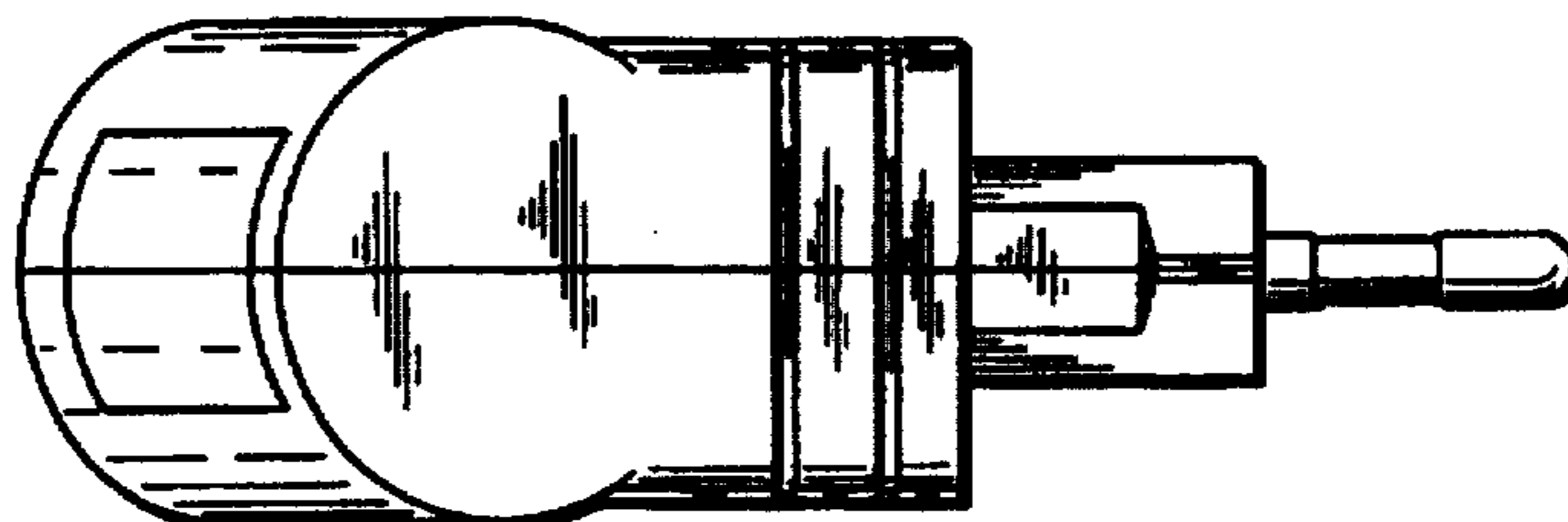

FIG. 83

