



US00D389438S

United States Patent [19]

[11] Patent Number: **Des. 389,438**

Guichard et al.

[45] Date of Patent: ****Jan. 20, 1998**

[54] VEHICLE BODY

[75] Inventors: **Gary D. Guichard; John P. Sgalia**, both of Farmington Hills; **Trevor M. Creed**, West Bloomfield, all of Mich.; **Michael Santoro**, La Costa, Calif.; **Ricardo Z. Aneiros**, Dearborn; **Clyde W. Ney**, Waterford, both of Mich.

[73] Assignee: **Chrysler Corporation**, Auburn Hills, Mich.

[**] Term: **14 Years**

[21] Appl. No.: **24,426**

[22] Filed: **Jun. 14, 1994**

[51] LOC (6) Cl. **12-08**

[52] U.S. Cl. **D12/98**

[58] Field of Search **D12/82-100, 401**

[56] References Cited

U.S. PATENT DOCUMENTS

- D. 172,124 5/1954 **Blenkle** D12/99 X
- D. 220,837 6/1971 **Mattson** D12/98

OTHER PUBLICATIONS

Automotive Industries, "Mighty Mite," p. 18, Feb. 1, 1959.
Automotive News, Datsun patrol, p. 254, 1963 Almanac Issue.

Motor Trend, Jeep CJ-7, p. 51, Mar. 1976.
Jeep Catalog, Jeep CJ-5, pp. 6, 7, 9, 1974.
"Car and Driver," Hummer, p. 108, 1992.

Primary Examiner—M. H. Tung
Attorney, Agent, or Firm—Mark P. Calcaterra

[57] CLAIM

The ornamental design for a vehicle body, as shown and described.

DESCRIPTION

FIG. 1 is a front, side perspective view of a vehicle body showing our new design;
 FIG. 2 is a rear perspective view of the vehicle body shown in FIG. 1;
 FIG. 3 is a side view of the vehicle body shown in FIG. 1, the opposite side view is a mirror image;
 FIG. 4 is an elevated front view of the vehicle body shown in FIG. 1;
 FIG. 5 is a front, top perspective view thereof, on an enlarged scale; and,
 FIG. 6 is a rear view thereof, the broken line drawing of the spare tire is not shown for clarity of illustration.
 The broken line drawing of the wheels and the interior details in all views are for illustrative purposes only and form no part of the claimed design.

1 Claim, 5 Drawing Sheets

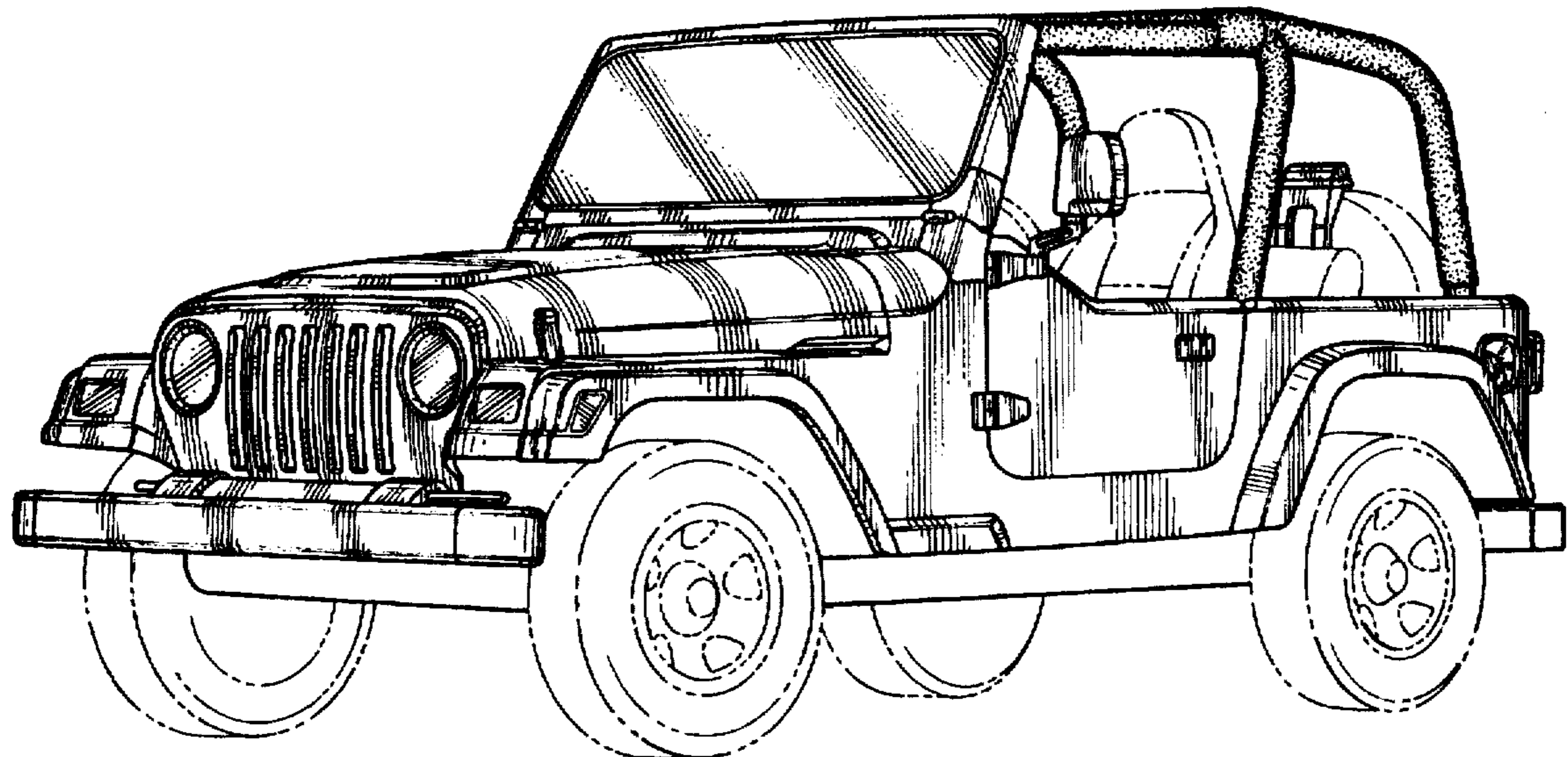

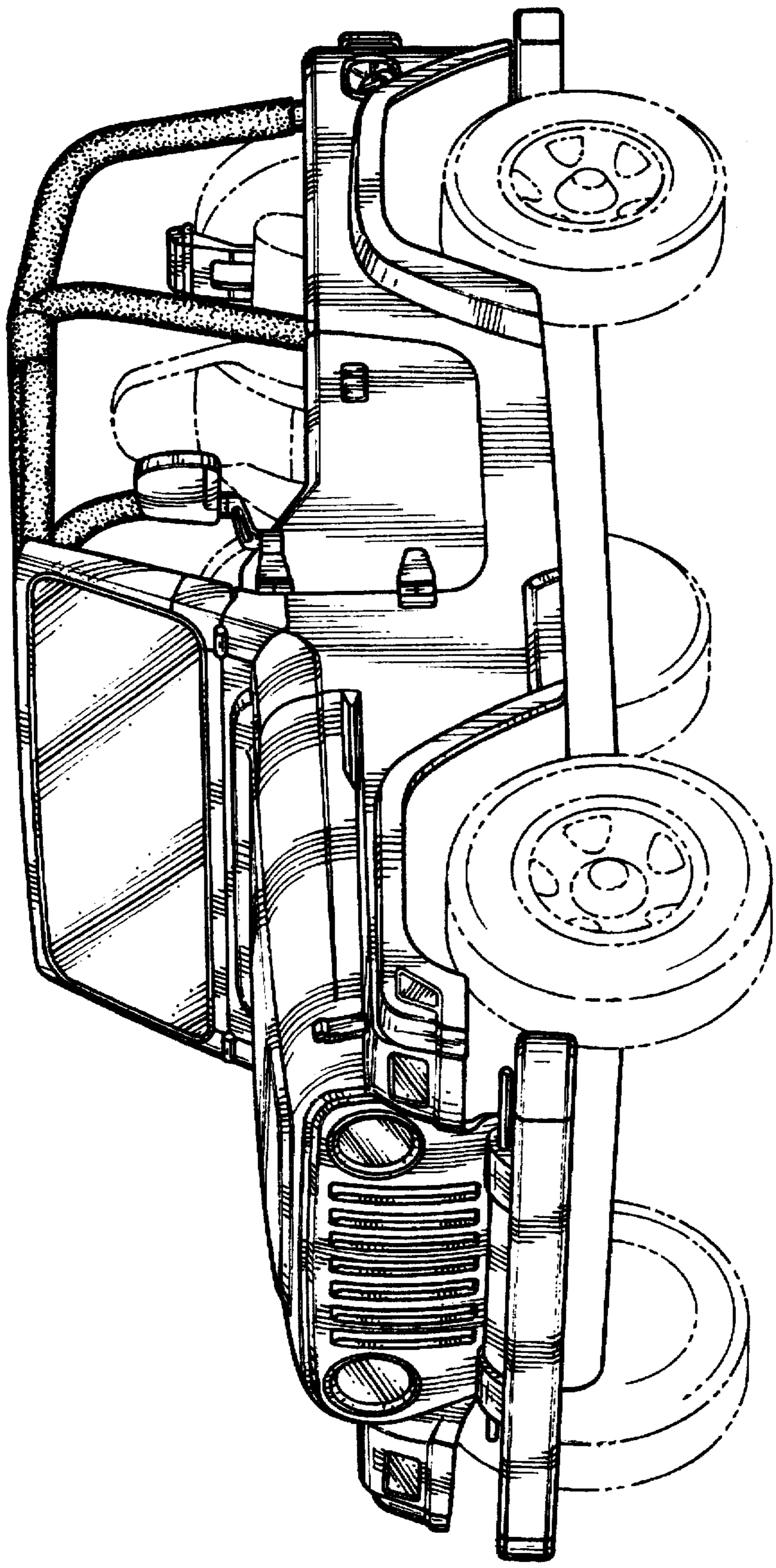

Fig - 1

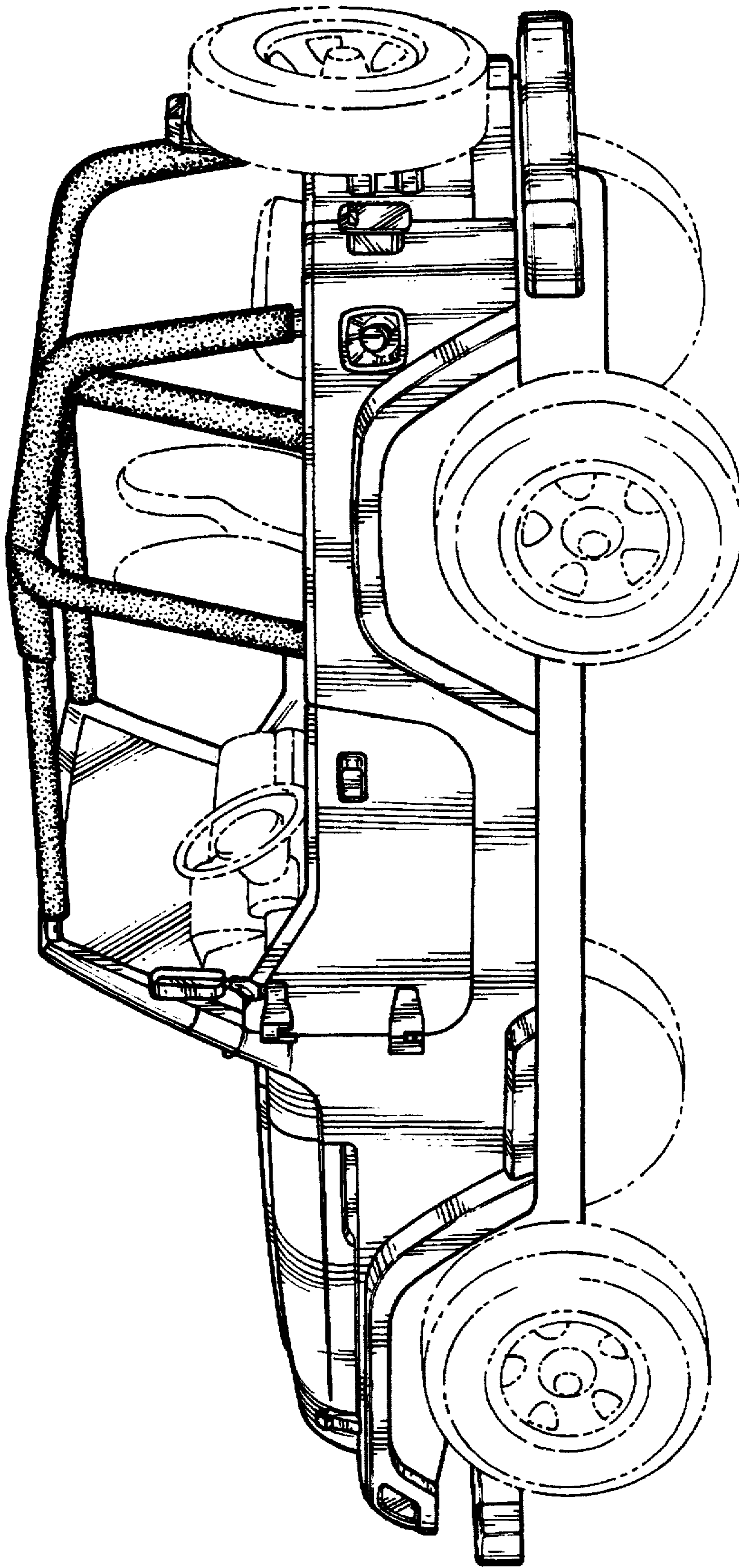

Fig - 2

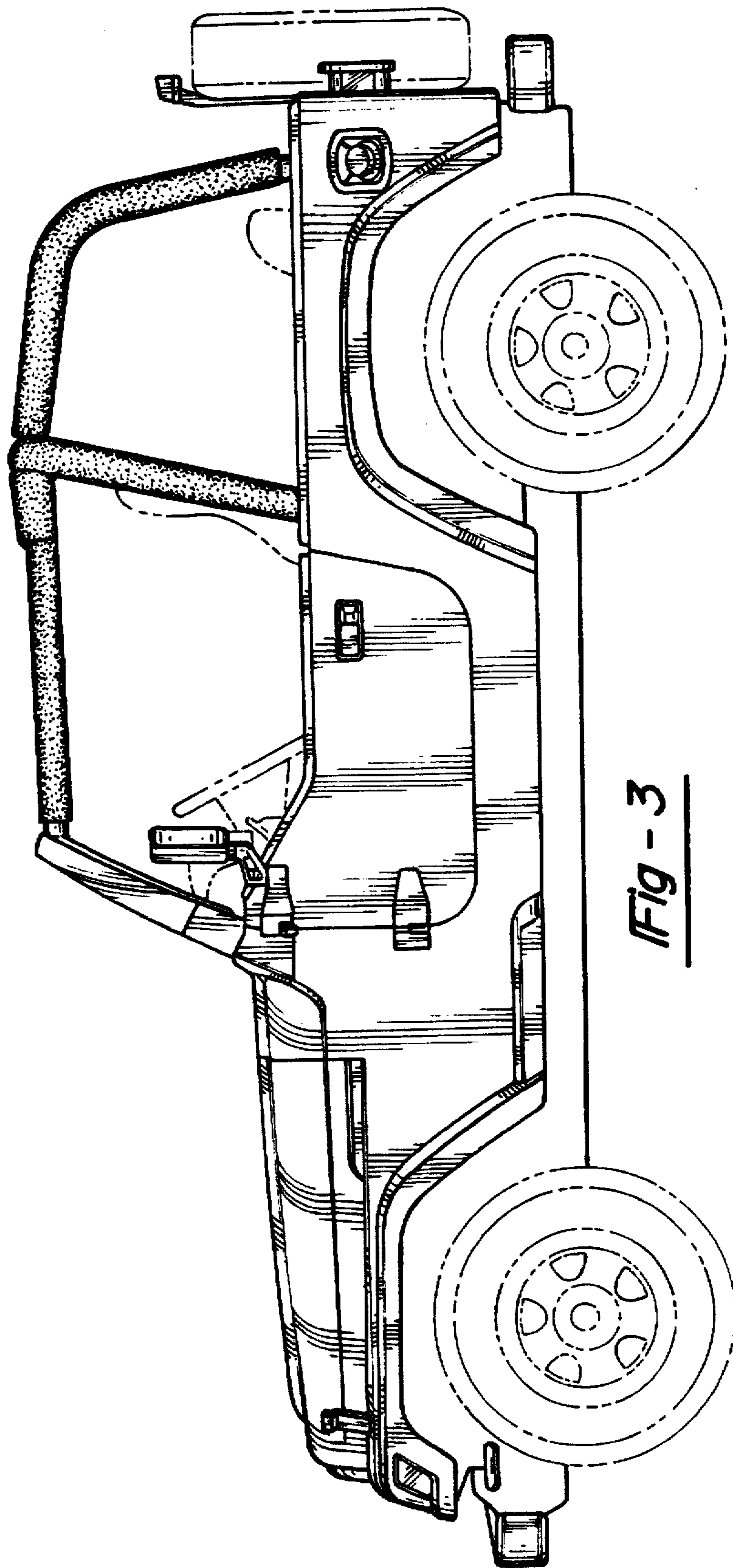

Fig - 3

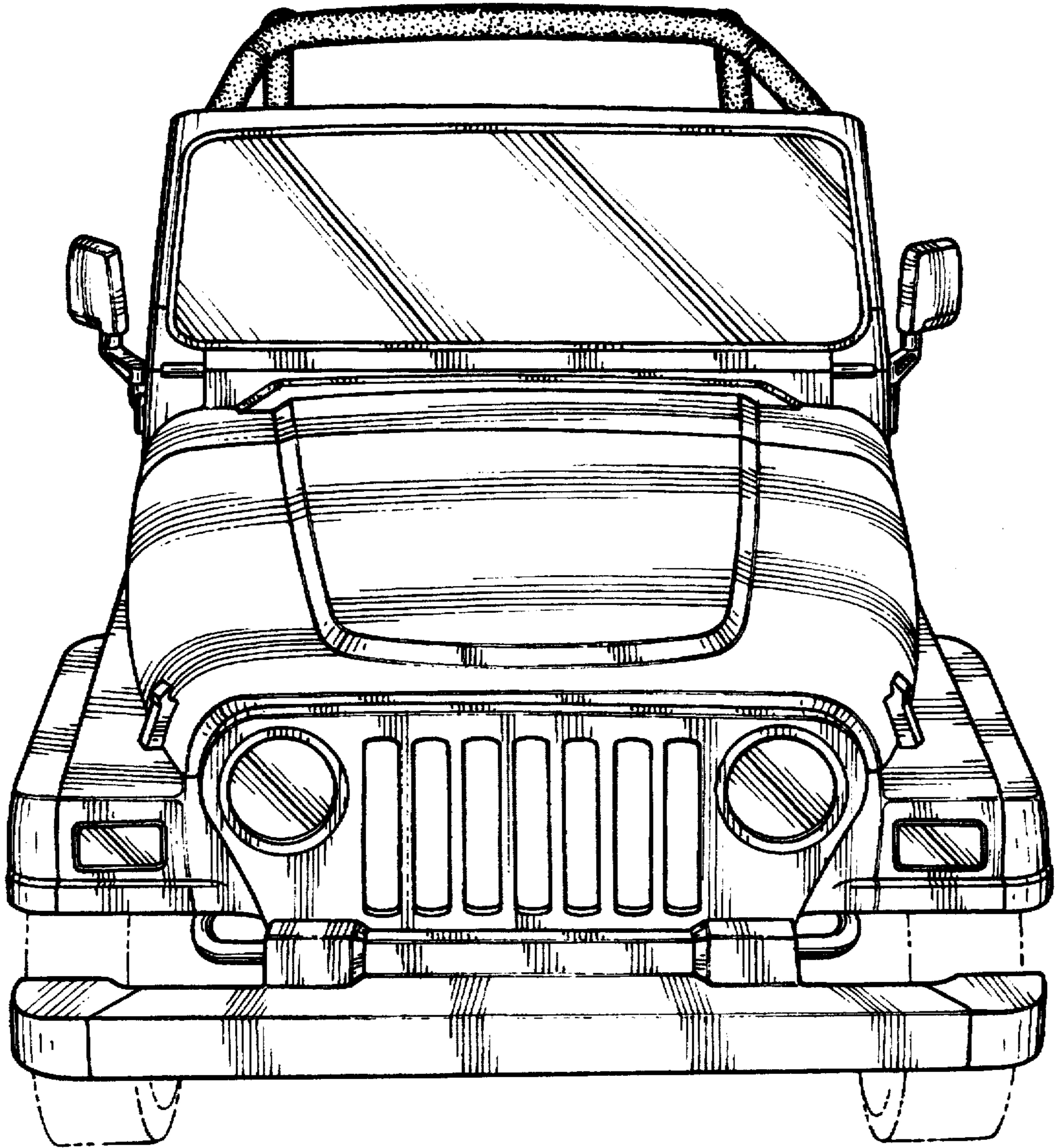

Fig - 4

