



US00D389417S

United States Patent [19]

Polacek et al.

[11] Patent Number: **Des. 389,417**

[45] Date of Patent: ****Jan. 20, 1998**

[54] **PEOPLE MOVER CABIN**

[75] Inventors: **Richard R. Polacek**, Farmington;
David Kaiser, North Haven, both of
Conn.; **Domenic Mercurio**, Bellevue,
Wash.

[73] Assignee: **Otis Elevator Company**, Farmington,
Conn.

[**] Term: **14 Years**

[21] Appl. No.: **53,731**

[22] Filed: **Apr. 29, 1996**

[51] LOC (6) CL **12-03**

[52] U.S. Cl. **D10/40; D12/1; D12/37**

[58] Field of Search **D12/1, 40, 37,**
D12/36, 43; 104/281; 105/141-148, 329.1

[56] **References Cited**

U.S. PATENT DOCUMENTS

D. 218,995	10/1970	Larsen	D12/37	X
D. 219,246	11/1970	Adams	D12/37	
D. 234,418	3/1975	Forsey	D12/40	
D. 236,602	9/1975	Sundberg	D12/37	
D. 317,886	7/1991	Stannard	D12/40	

OTHER PUBLICATIONS

The Rosslyn Review—May 25, 1972, p. 3—“PRT Vehicle” at
top-left.

The Rosslyn Review—May 25, 1972, p. 6—“Mono Cab
Vehicle” at top.

Industrial Design—Jan. 2, 1973—p. 54—“Airtrans Vehicle”
at top.

Modern Plastics—Jan. 1973—p. 71—“RP Vehicle” at bot-
tom-right.

Primary Examiner—Nelson C. Holtje

[57] **CLAIM**

The ornamental design for a people mover cabin, as shown
and described.

DESCRIPTION

FIG. 1 is a perspective view of the people mover cabin
embodying our new design;

FIG. 2 is a left side view thereof;

FIG. 3 is a top view thereof;

FIG. 4 is a back view thereof;

FIG. 5 is a front view thereof;

FIG. 6 is a right side view thereof;

FIG. 7 is a perspective view of a second embodiment of the
people mover cabin of our design;

FIG. 8 is a left side view thereof;

FIG. 9 is a top view thereof;

FIG. 10 is a back view thereof;

FIG. 11 is a front view thereof; and,

FIG. 12 is a right side view thereof.

1 Claim, 6 Drawing Sheets

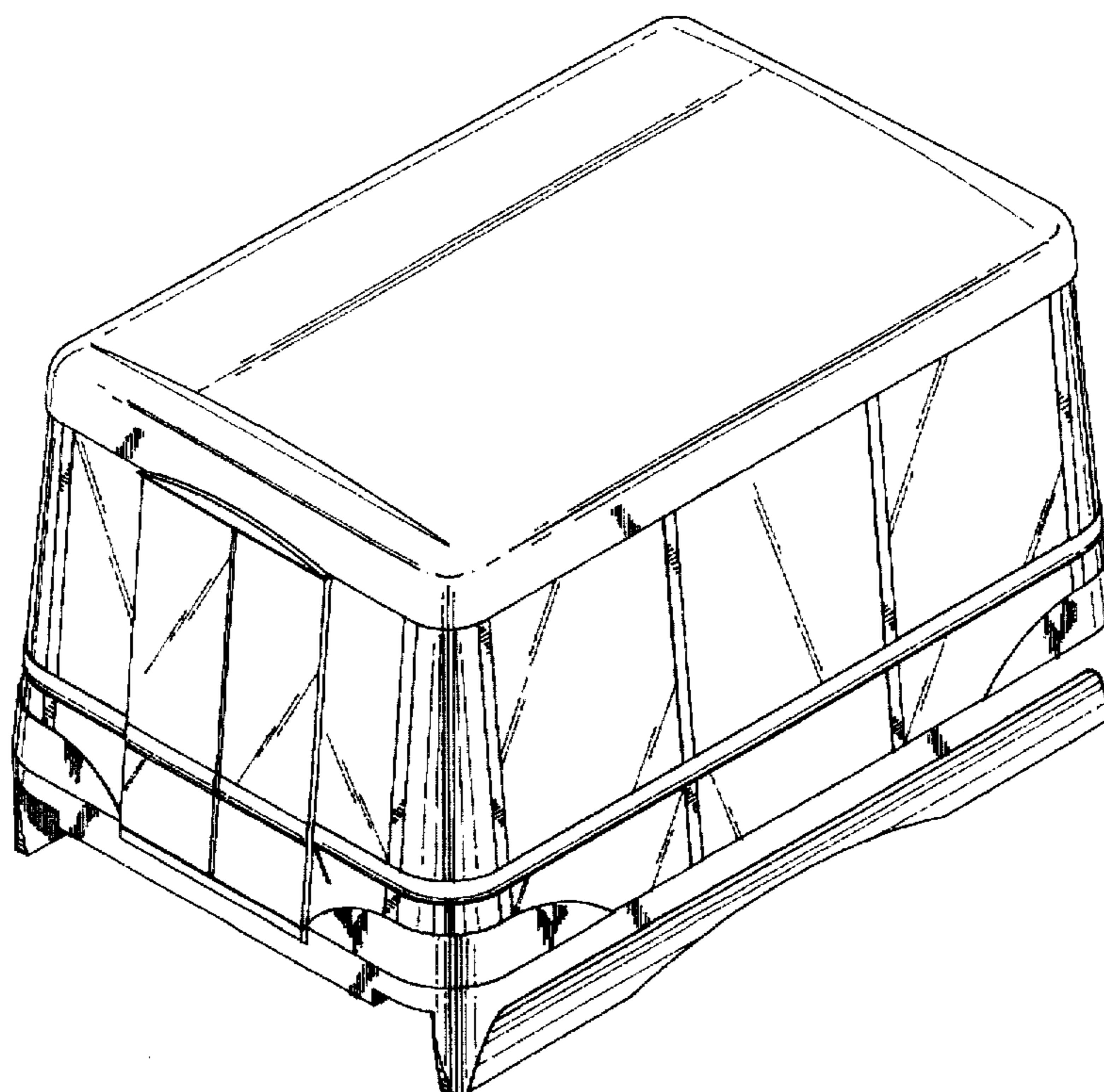

FIG. 1

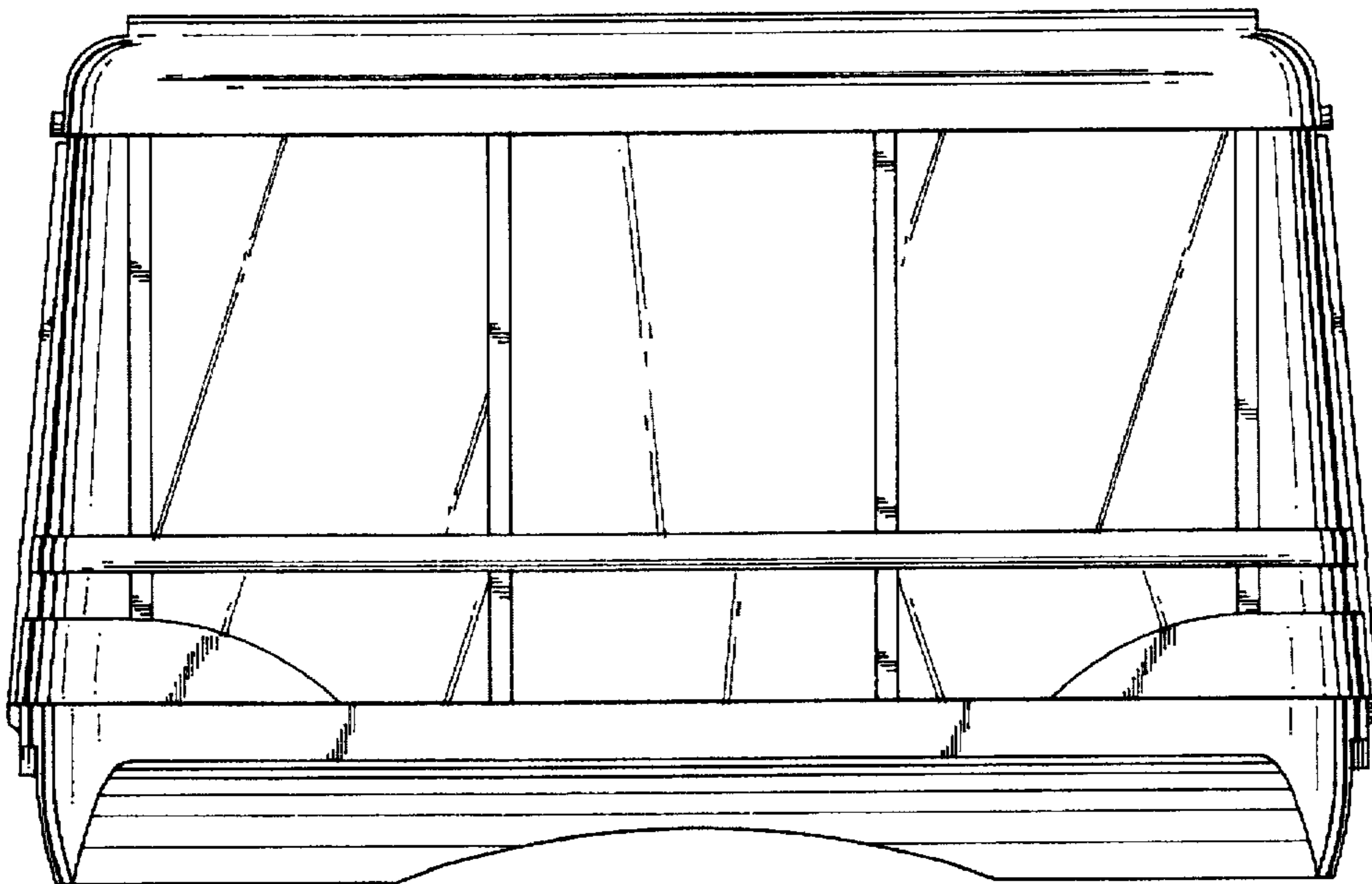
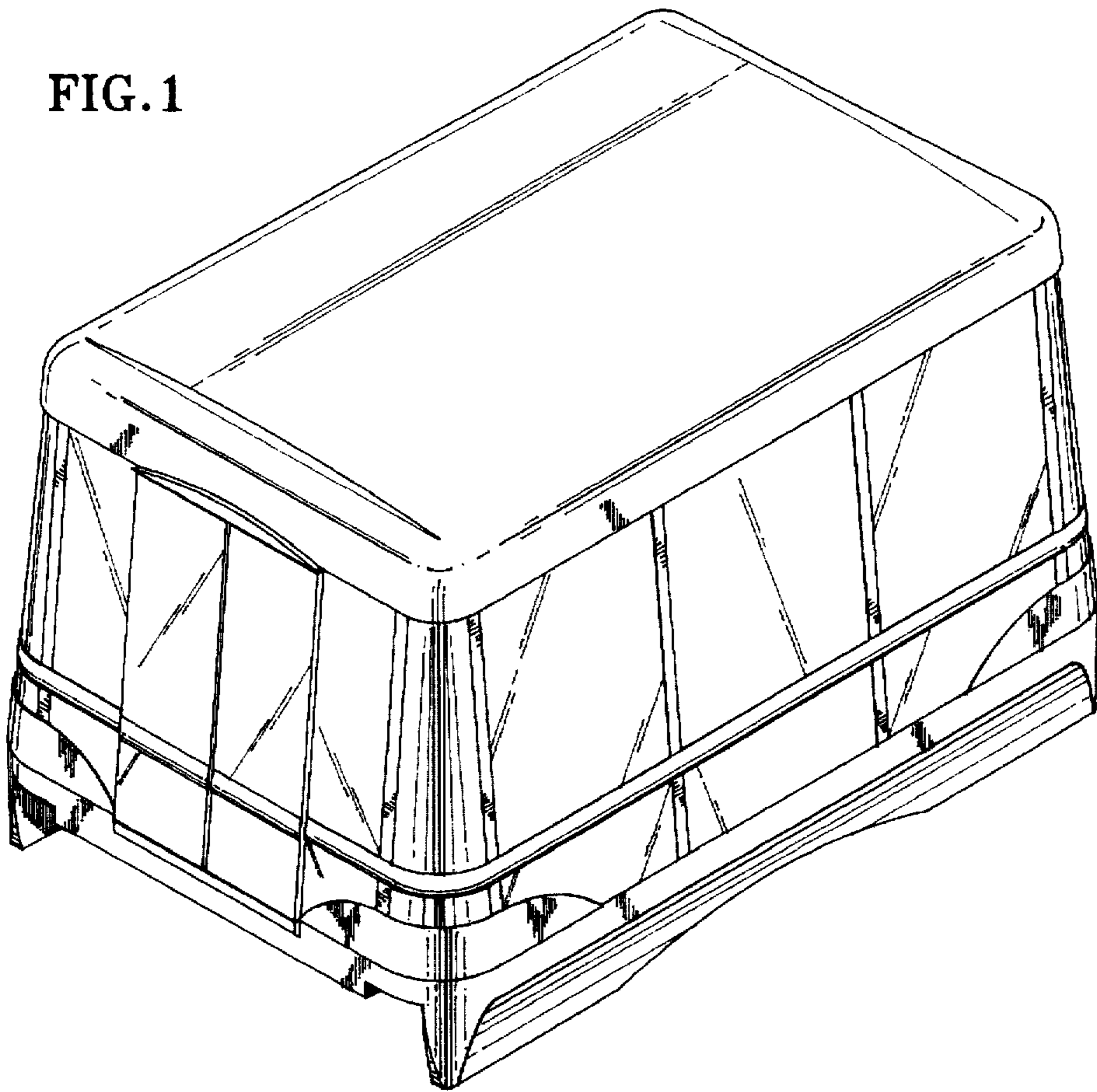

FIG. 2

FIG.3

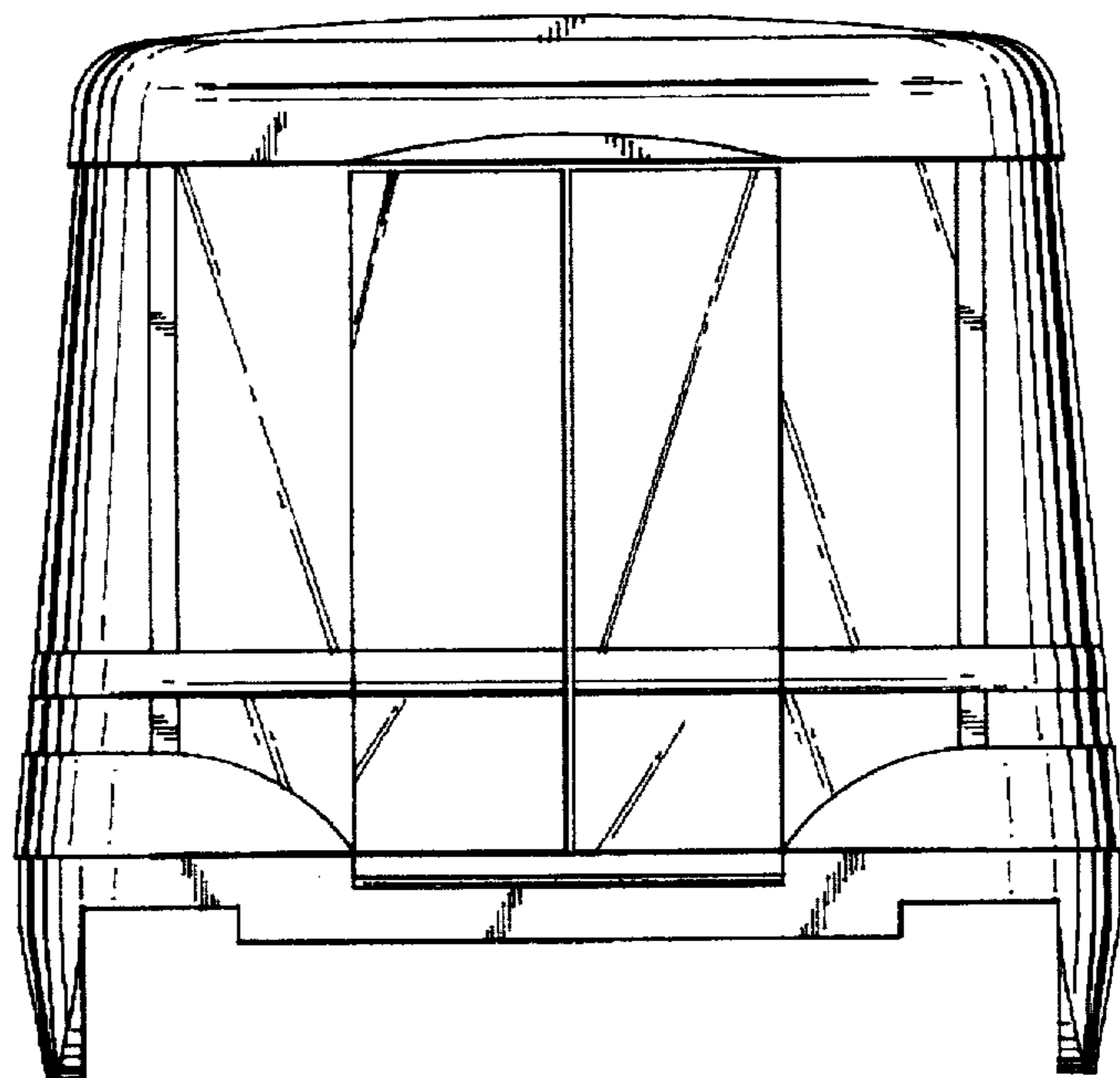
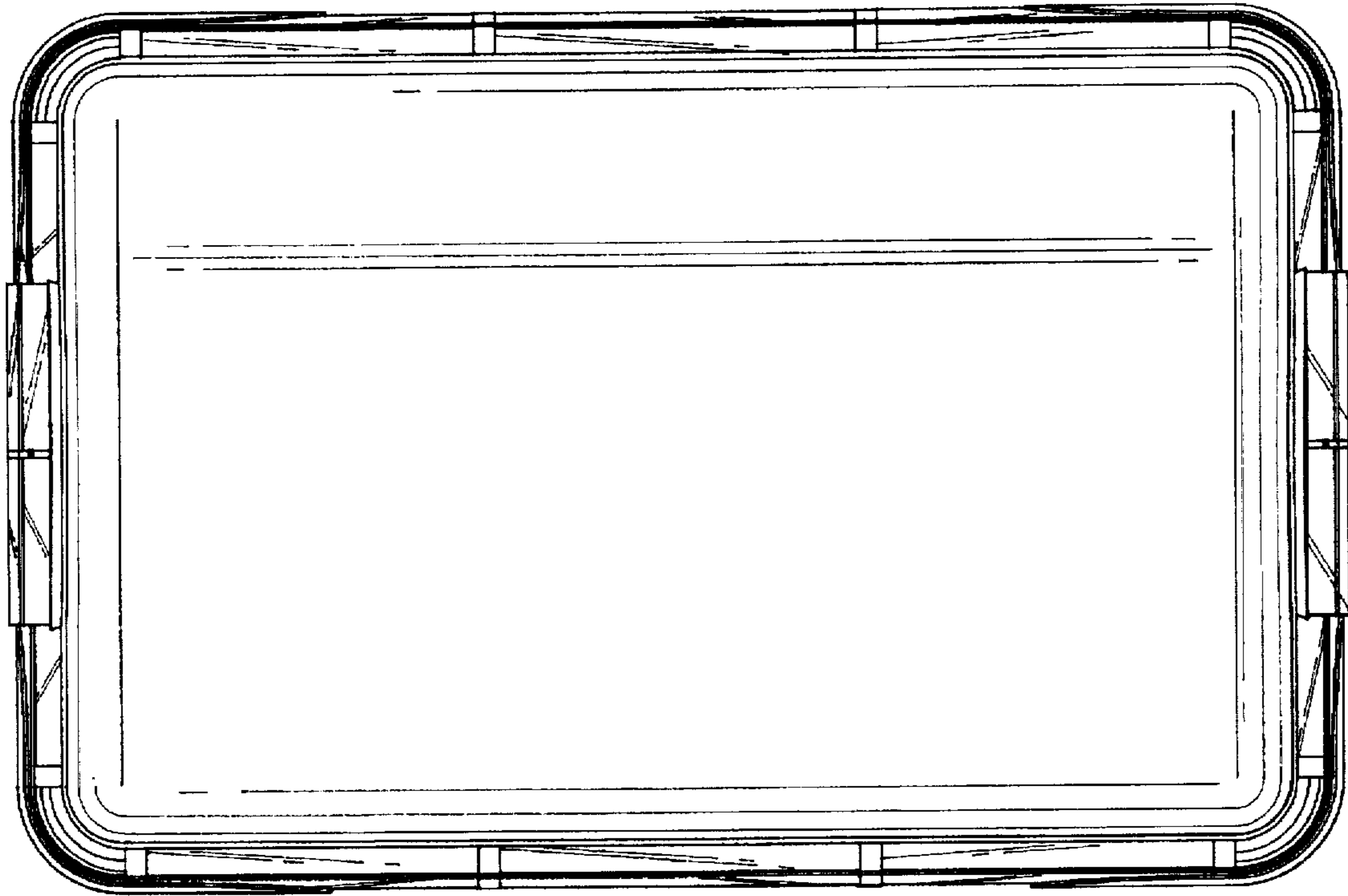

FIG.4

FIG.5

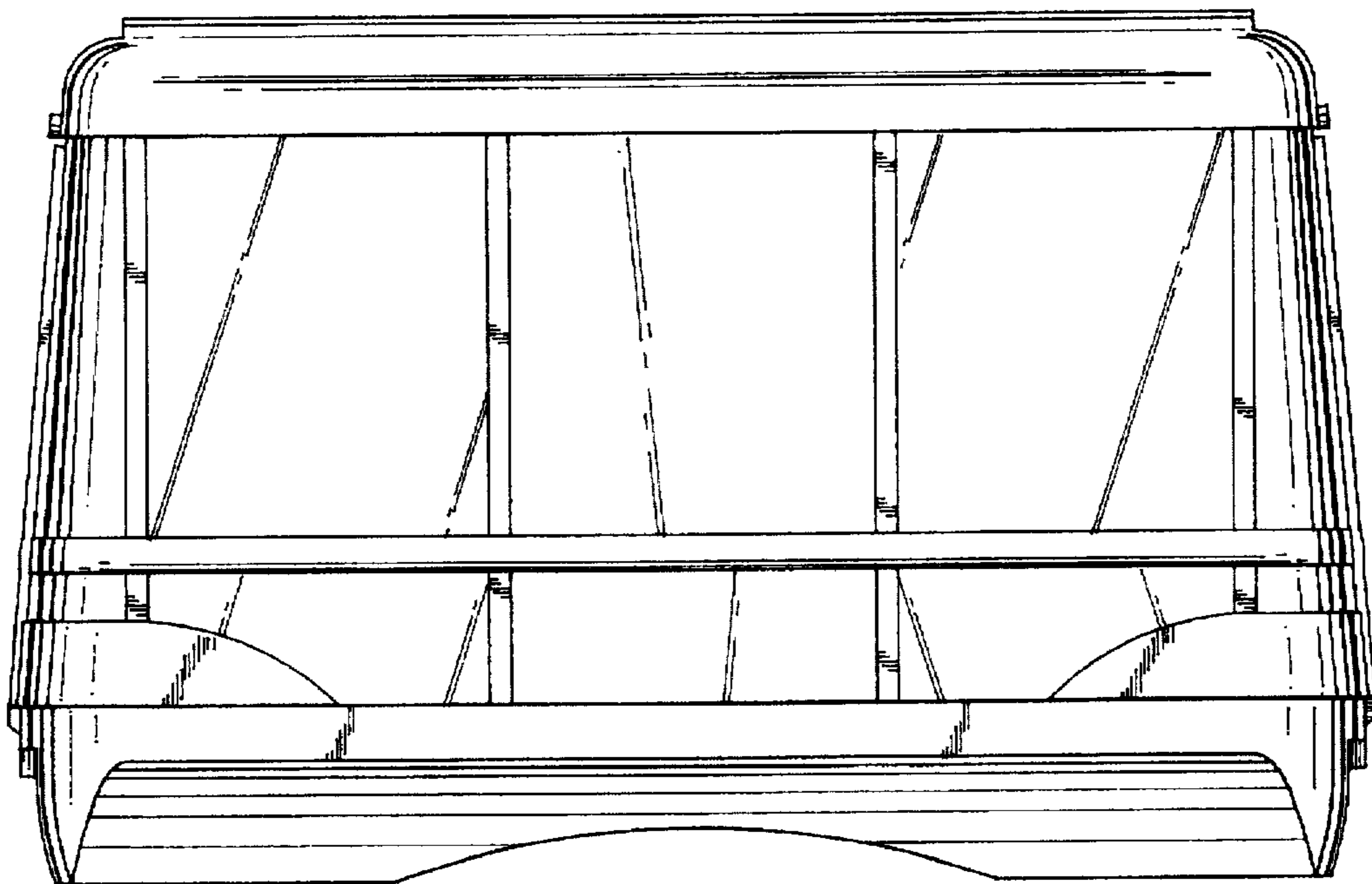
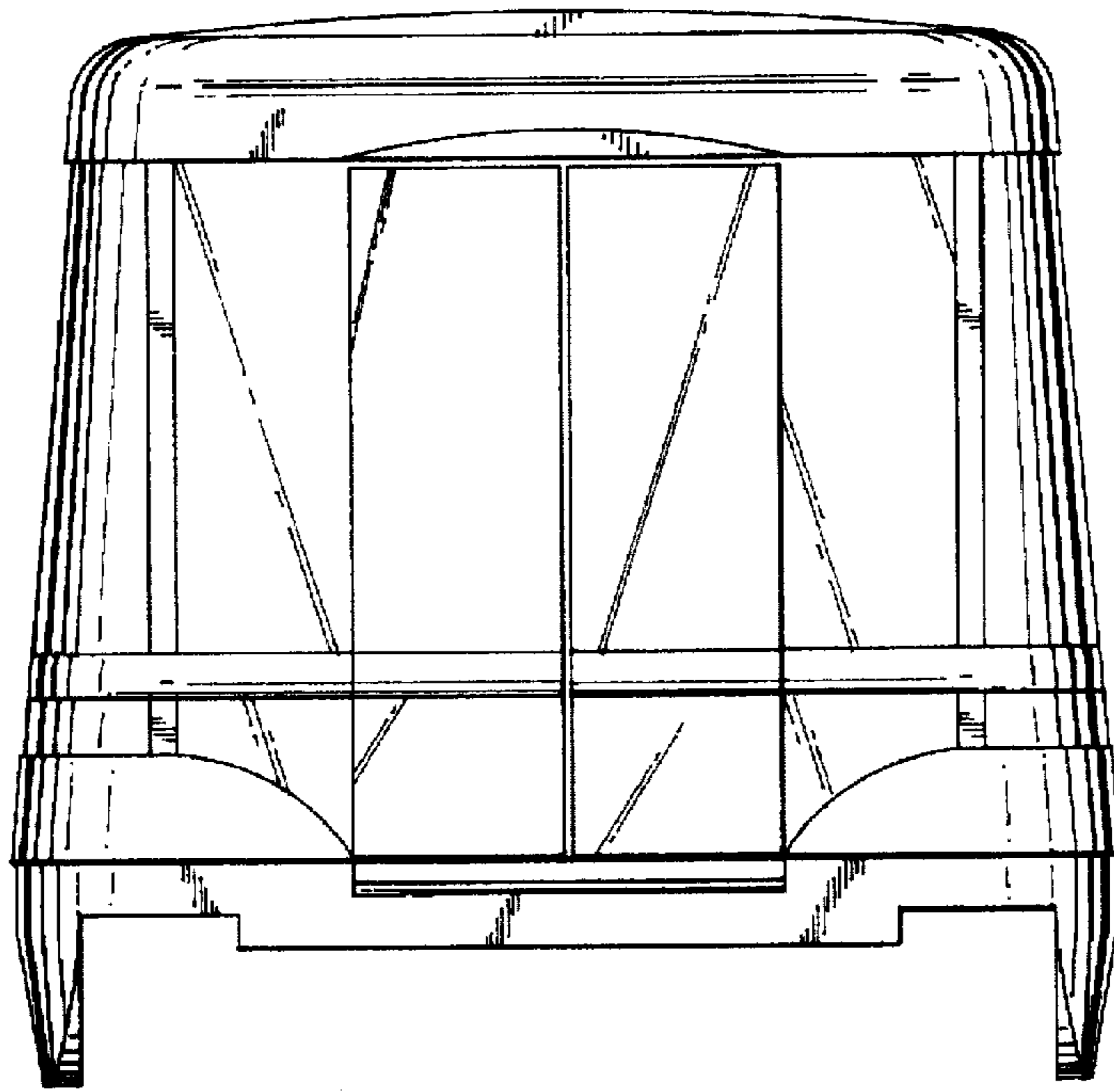

FIG.6

FIG. 7

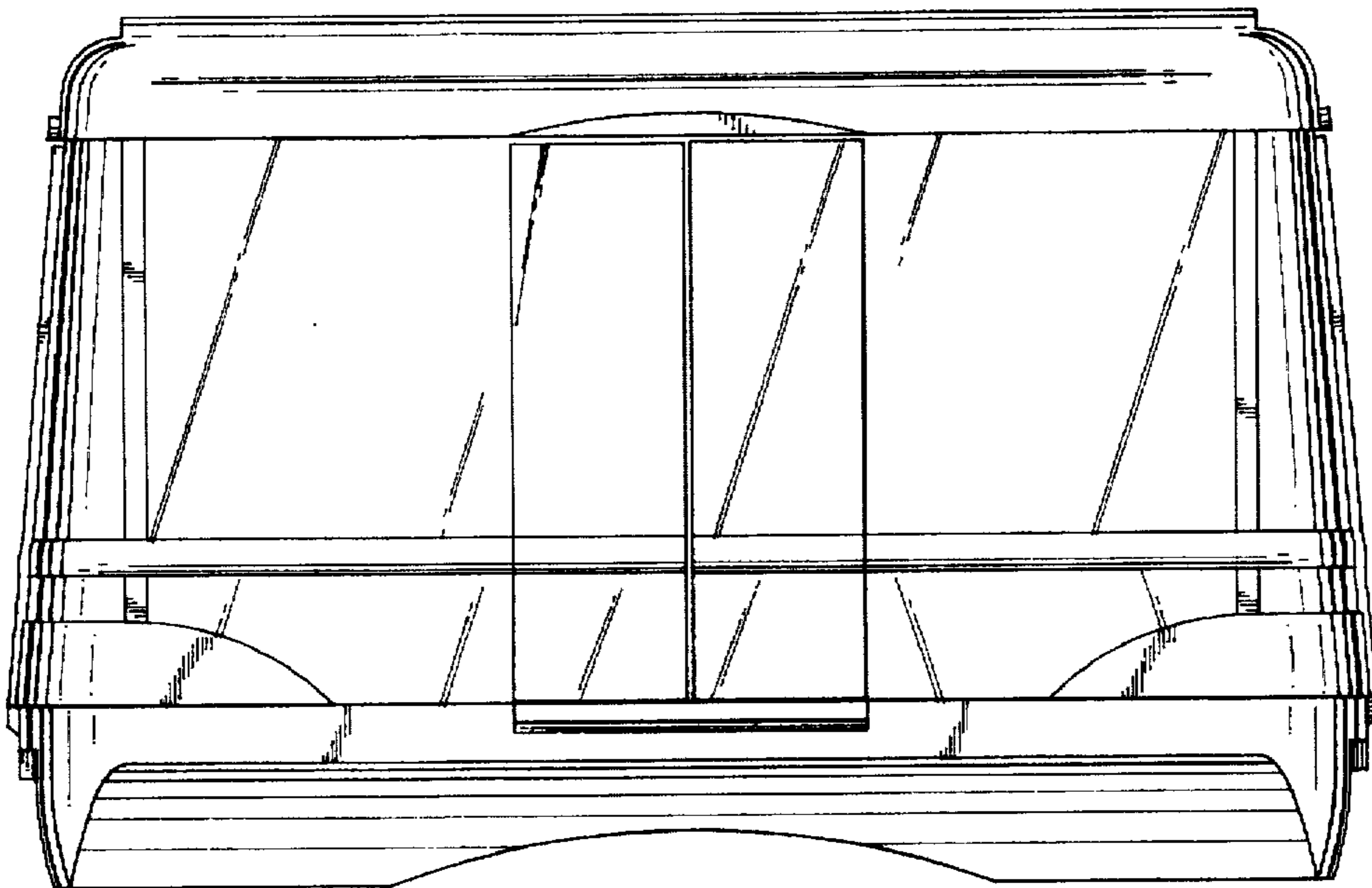
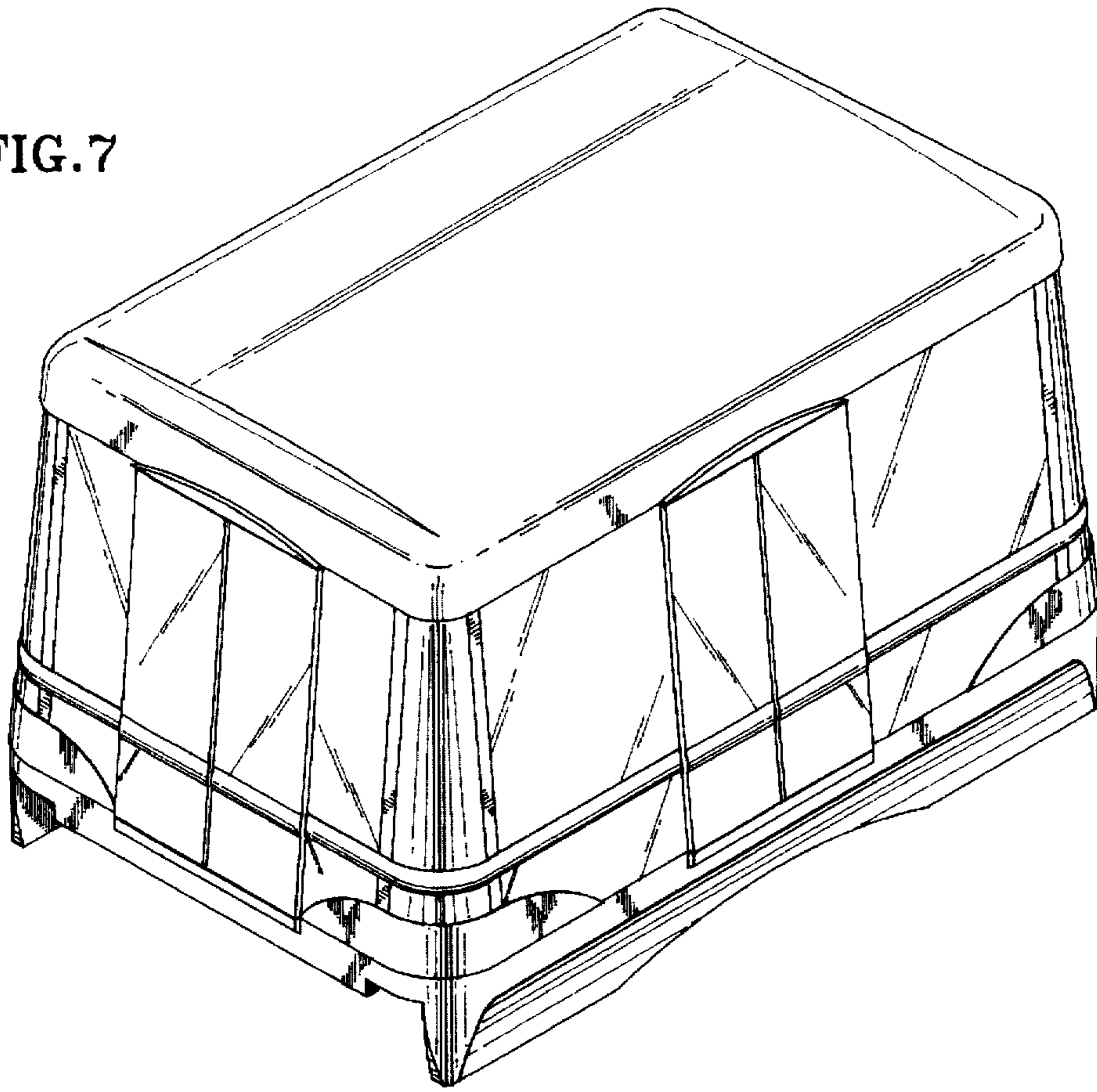

FIG. 8

FIG. 9

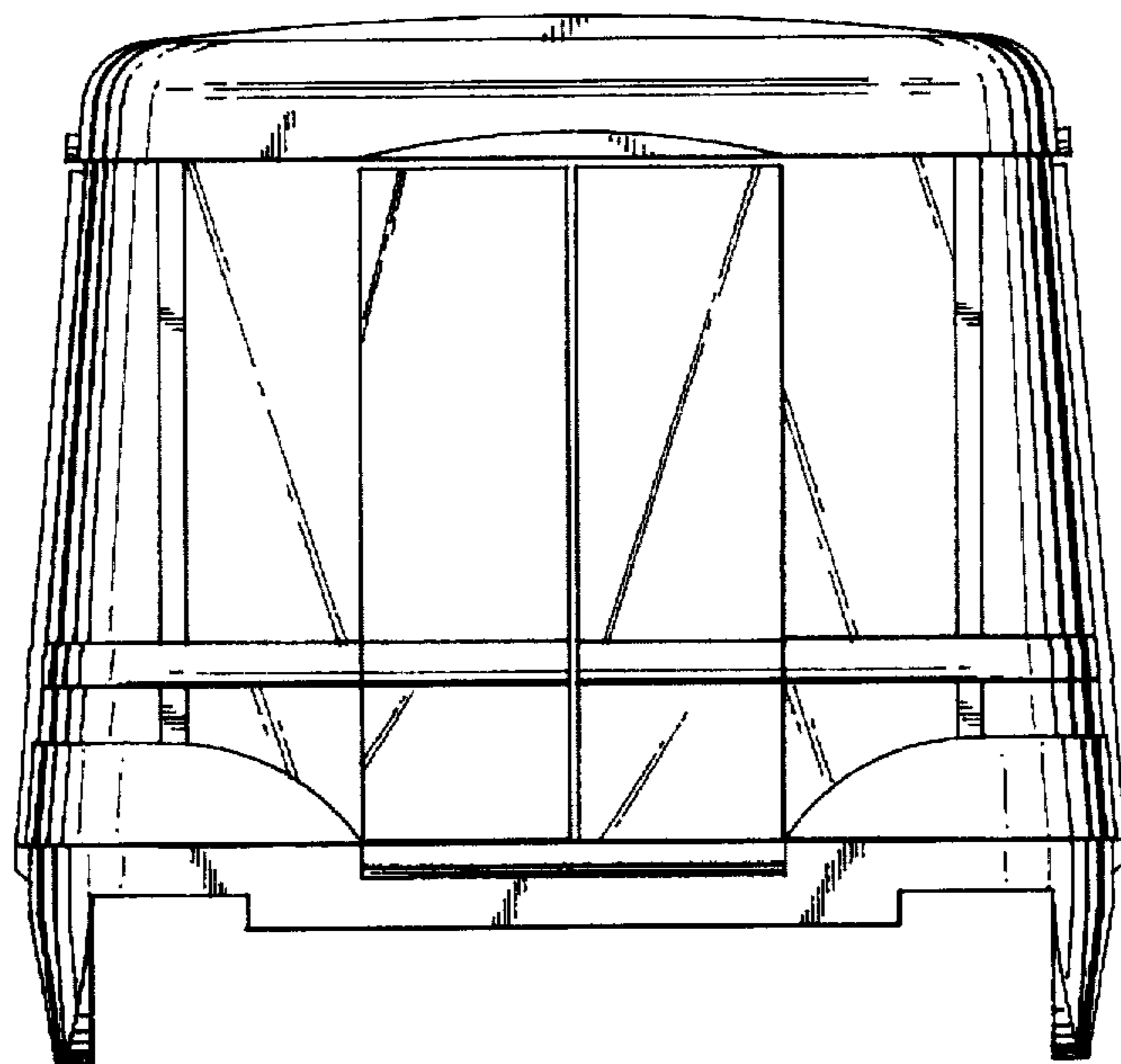
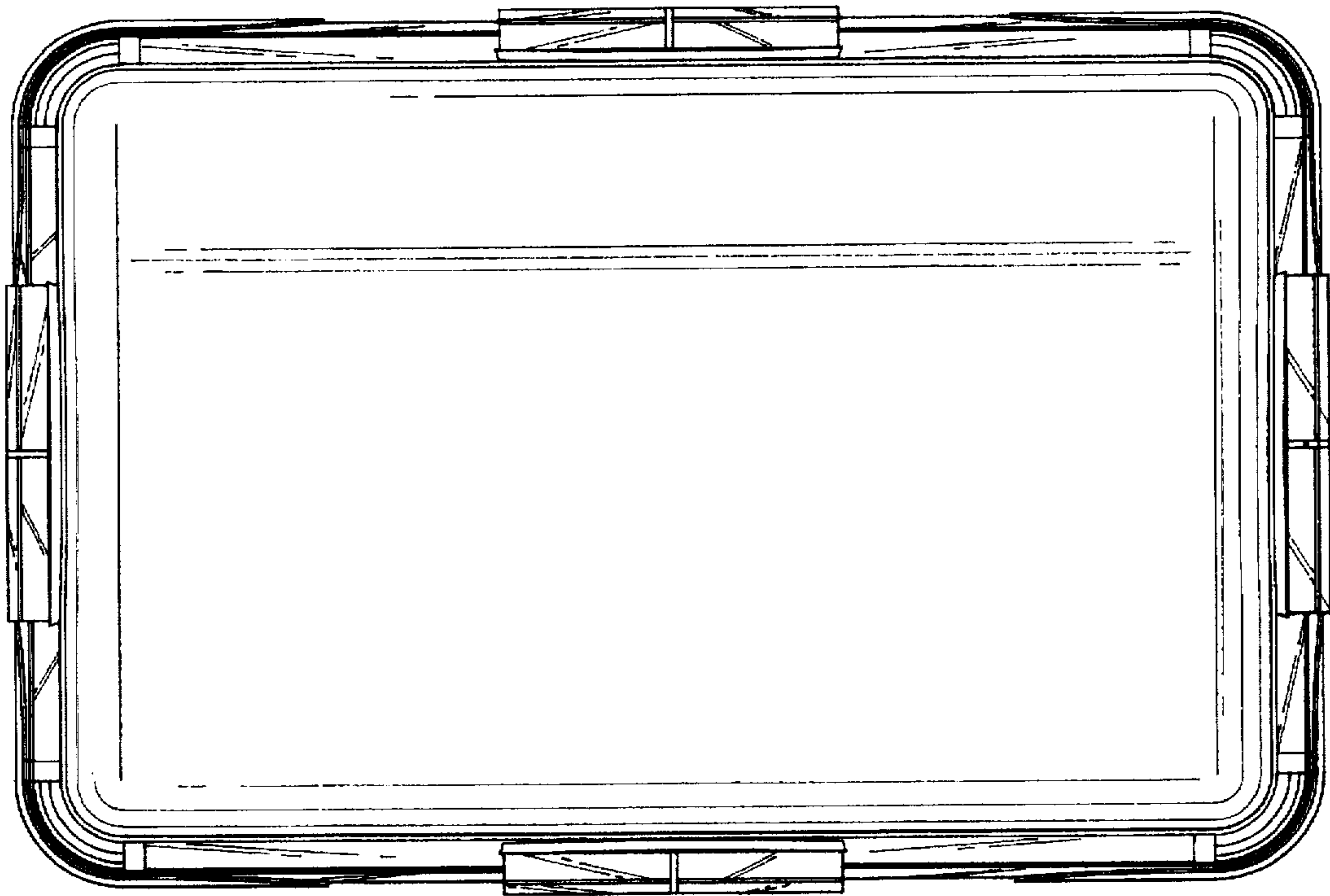

FIG. 10

FIG. 11

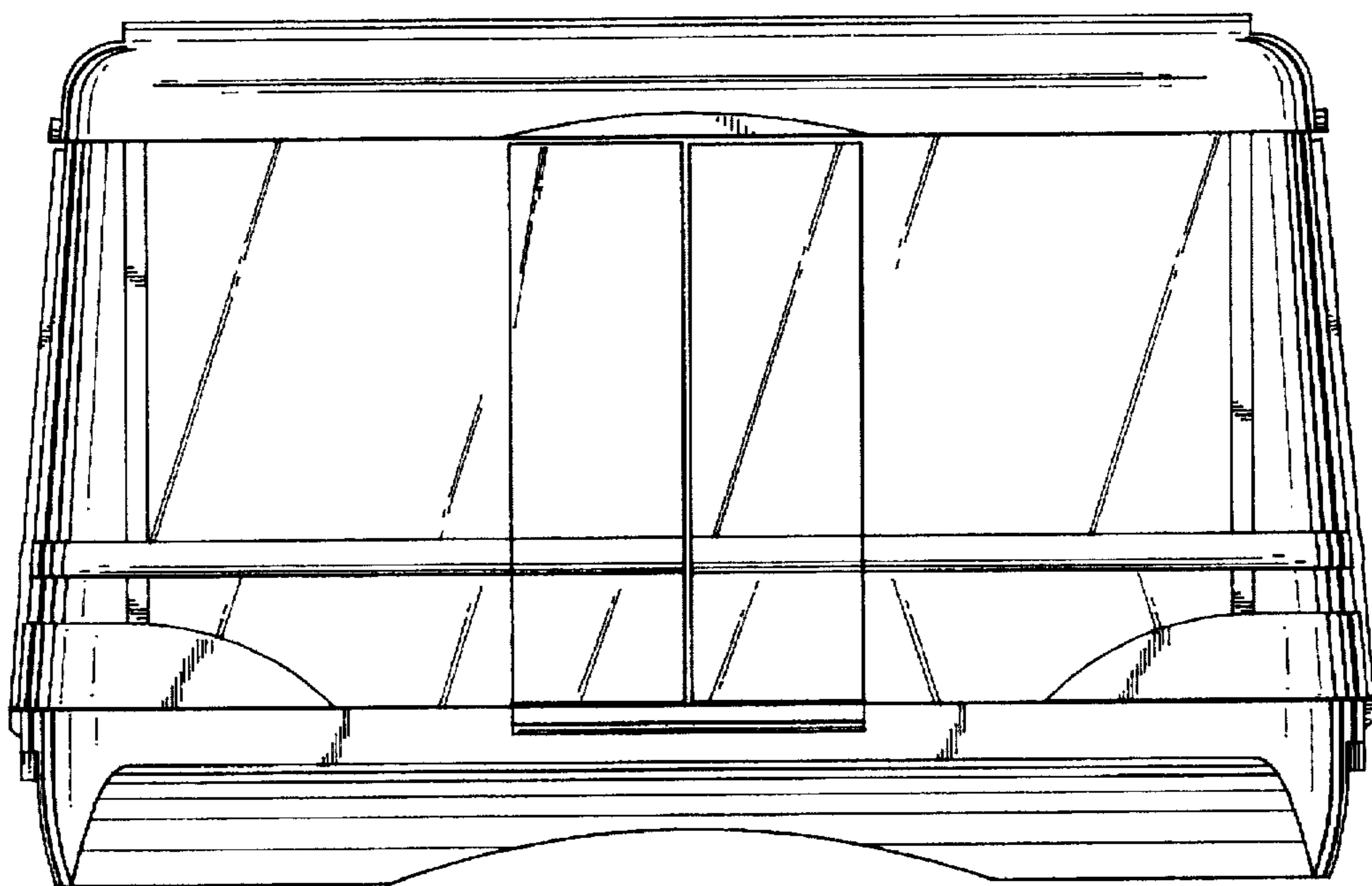
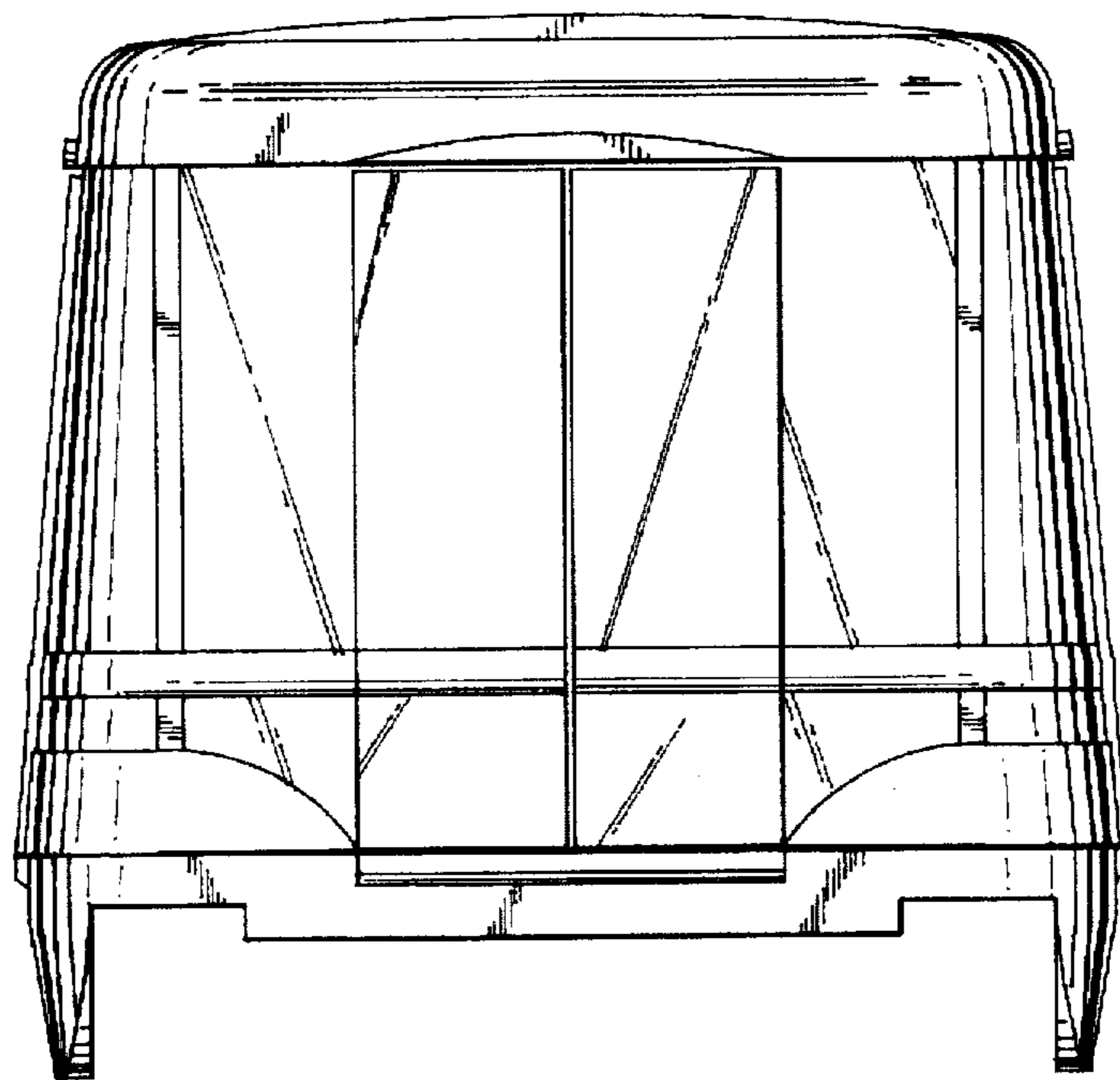

FIG. 12