



US00D389395S

United States Patent [19]
Gencarelli

[11] **Patent Number: Des. 389,395**
[45] **Date of Patent: **Jan. 20, 1998**

- [54] **EMERGENCY BRAKE LOCK**
- [76] **Inventor: Anthony J. Gencarelli, 94/1026 Aoku St., Waipahu, Hi. 96797**
- [**] **Term: 14 Years**
- [21] **Appl. No.: 49,859**
- [22] **Filed: Feb. 1, 1996**
- [51] **LOC (6) Cl. 08-07**
- [52] **U.S. Cl. D8/331**
- [58] **Field of Search D8/330, 331, 339, D8/341, 346; 70/207-211, 214-215, 225, 226, 237-238; 292/285**

D. 368,645 4/1996 Chen D8/331
5,325,688 7/1994 Jaw-Jia 70/209 X

Primary Examiner—Brian N. Vinson
Attorney, Agent, or Firm—Harold H. Dutton, Jr.

[57] **CLAIM**

The ornamental design for an emergency brake lock, as shown and described.

DESCRIPTION

FIG. 1 is a perspective view of an emergency brake lock showing my new design, the broken-line disclosure of a portion of an emergency brake being for illustrative purposes only and forming no part of the claimed design; FIG. 2 is a right side elevational view thereof; FIG. 3 is a left side elevational view thereof; FIG. 4 is a front elevational view thereof; and, FIG. 5 is a rear elevational view thereof.

[56] **References Cited**

U.S. PATENT DOCUMENTS

- D. 356,023 3/1995 Nicoara D8/333
- D. 356,937 4/1995 Hsiao D8/333

1 Claim, 3 Drawing Sheets

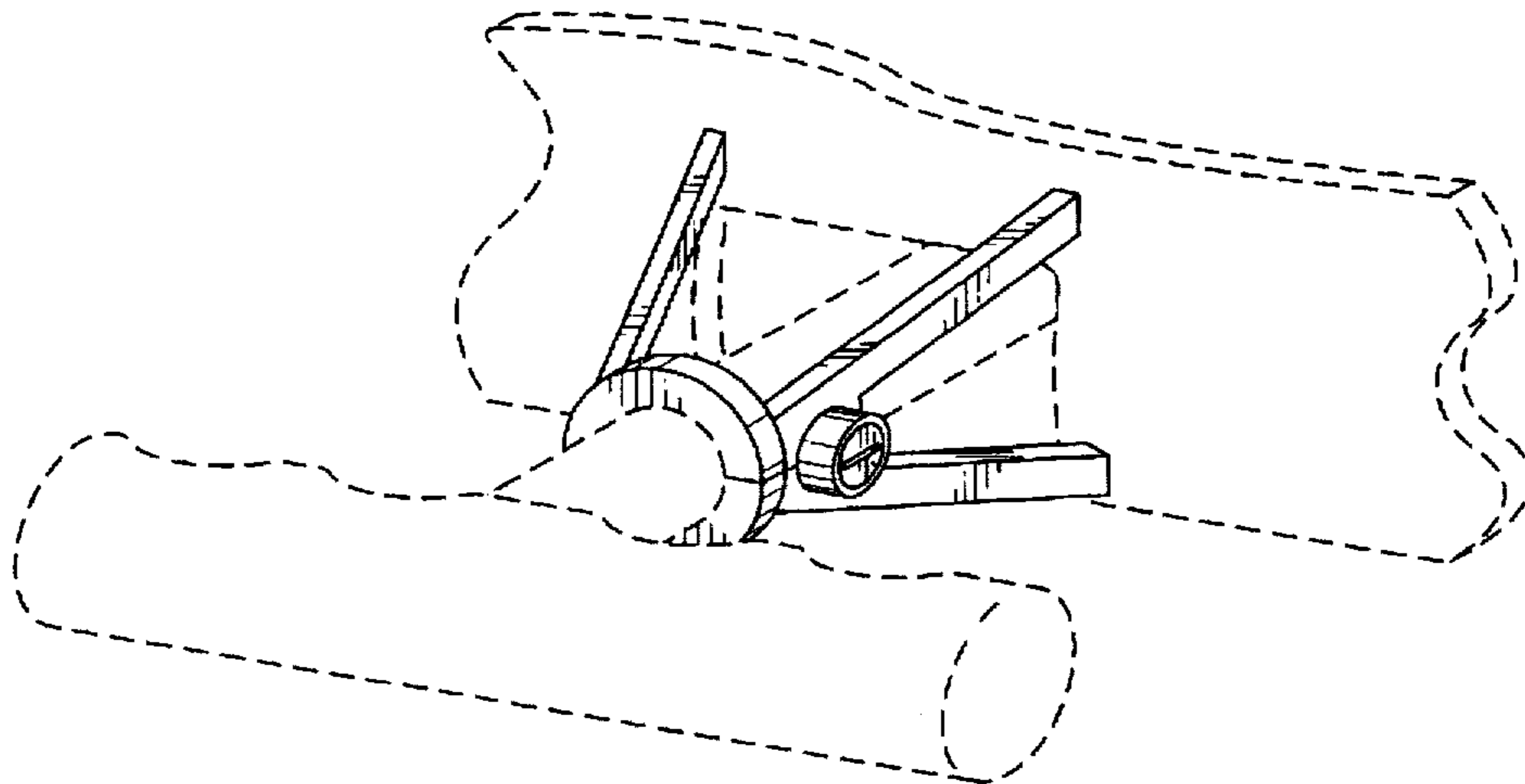

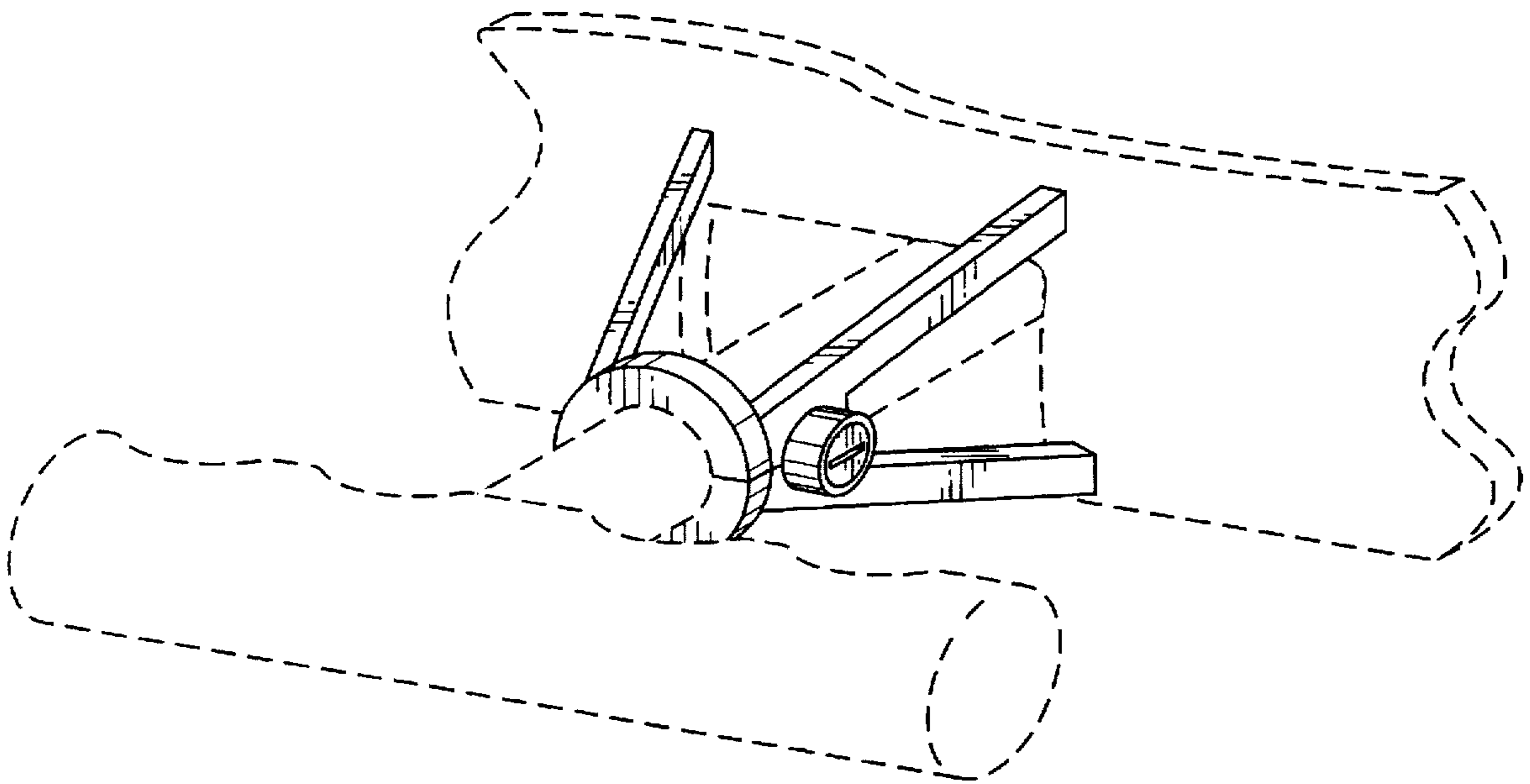

FIG. 1

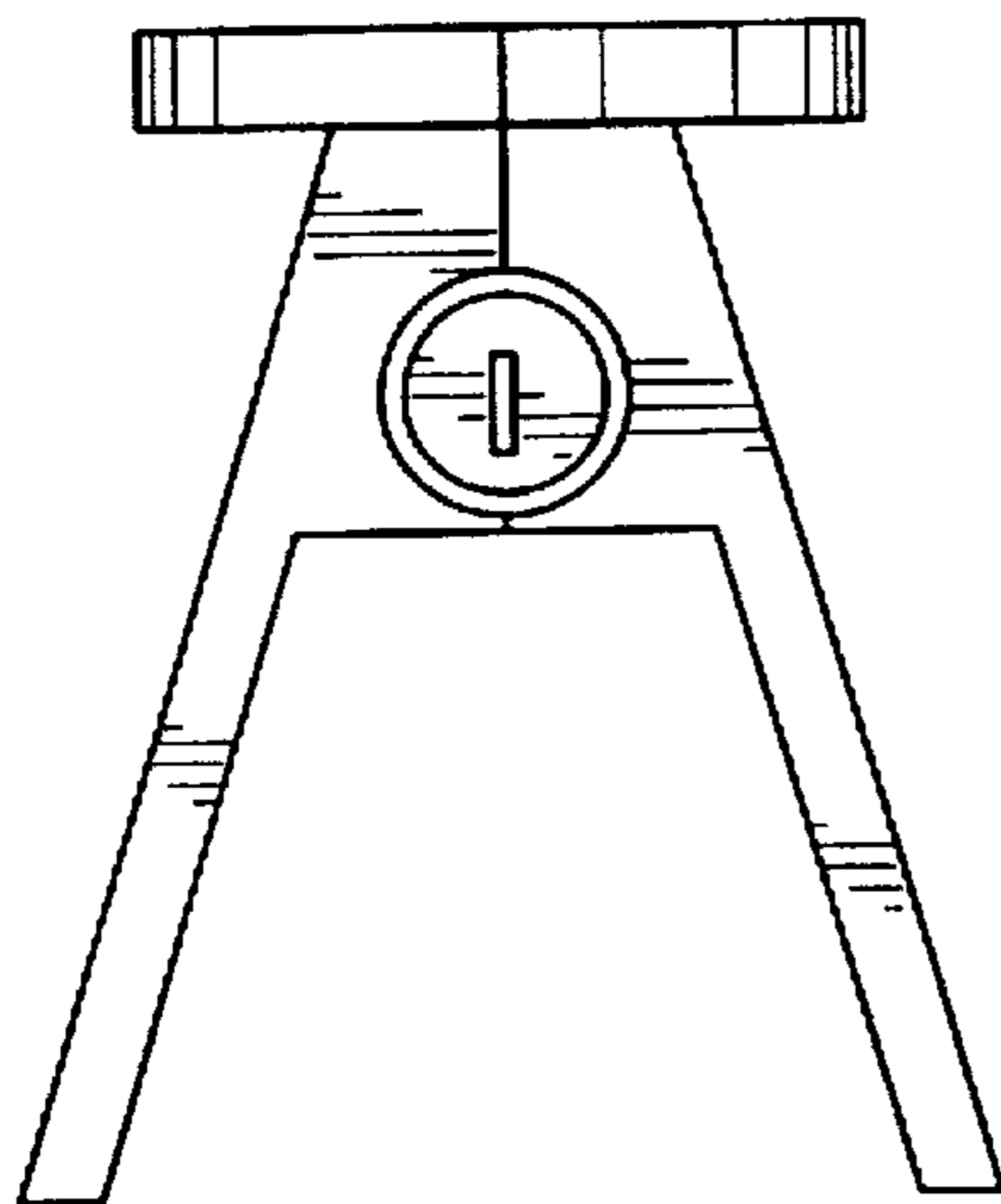

FIG. 2

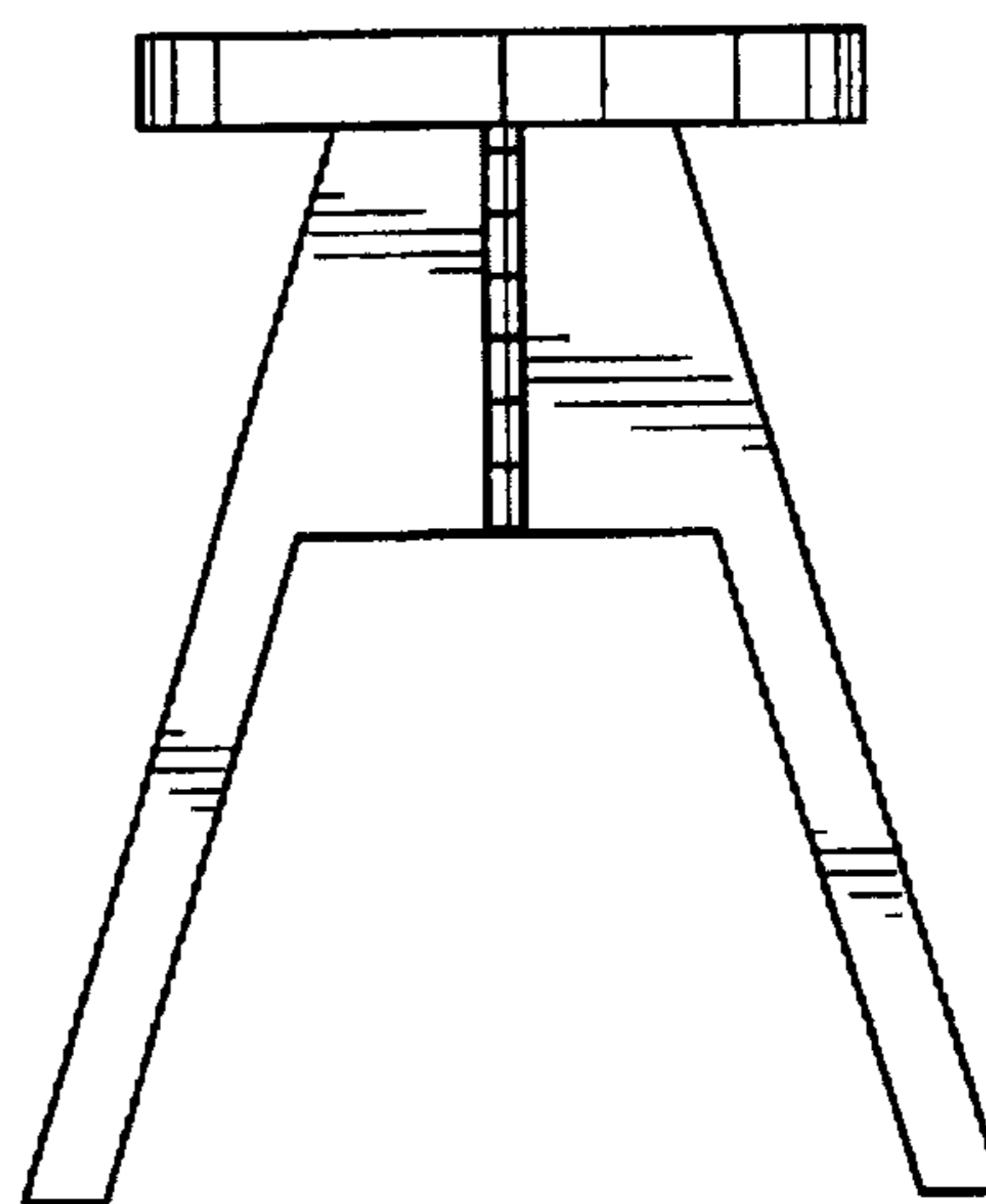

FIG. 3

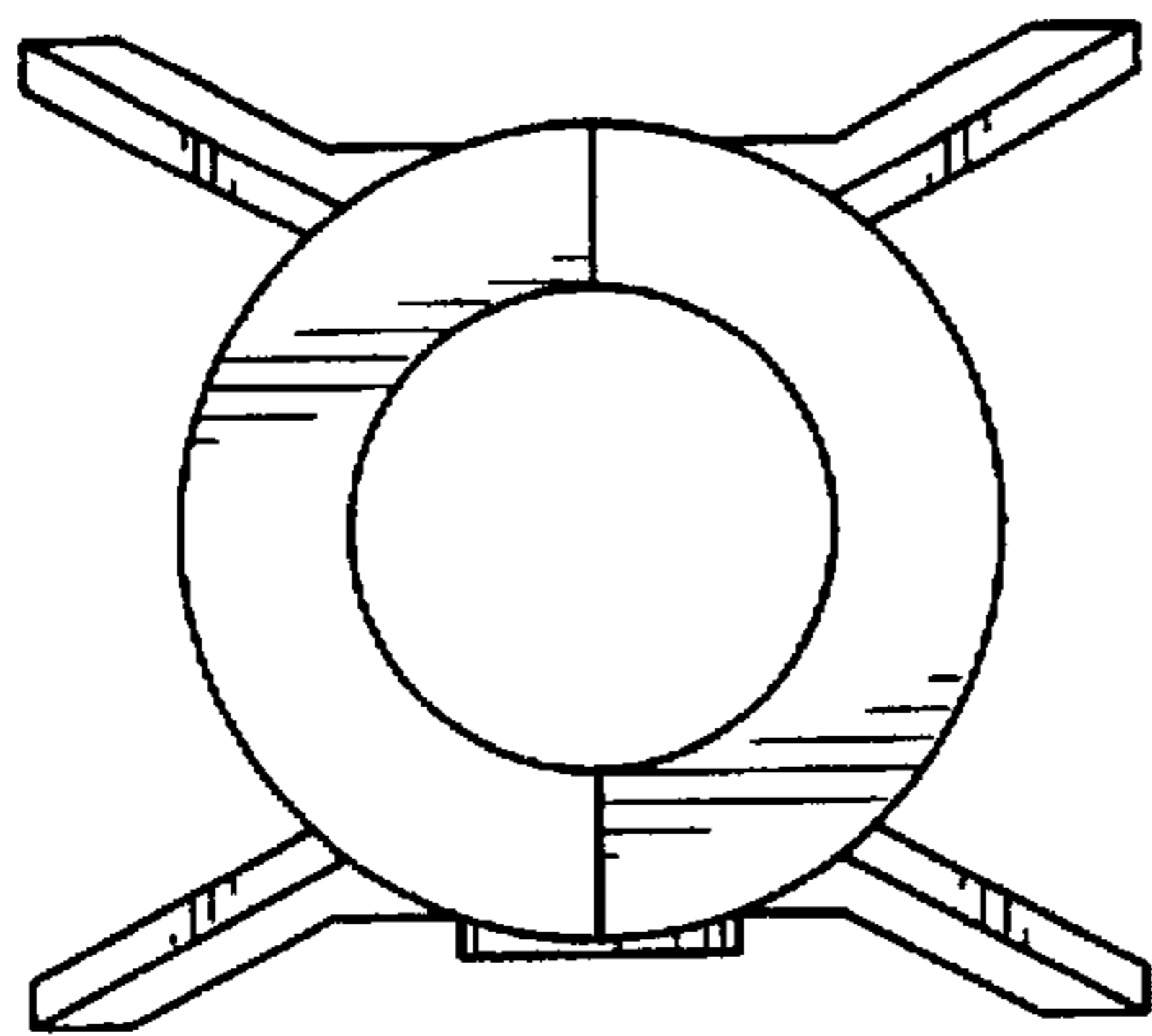

FIG. 4

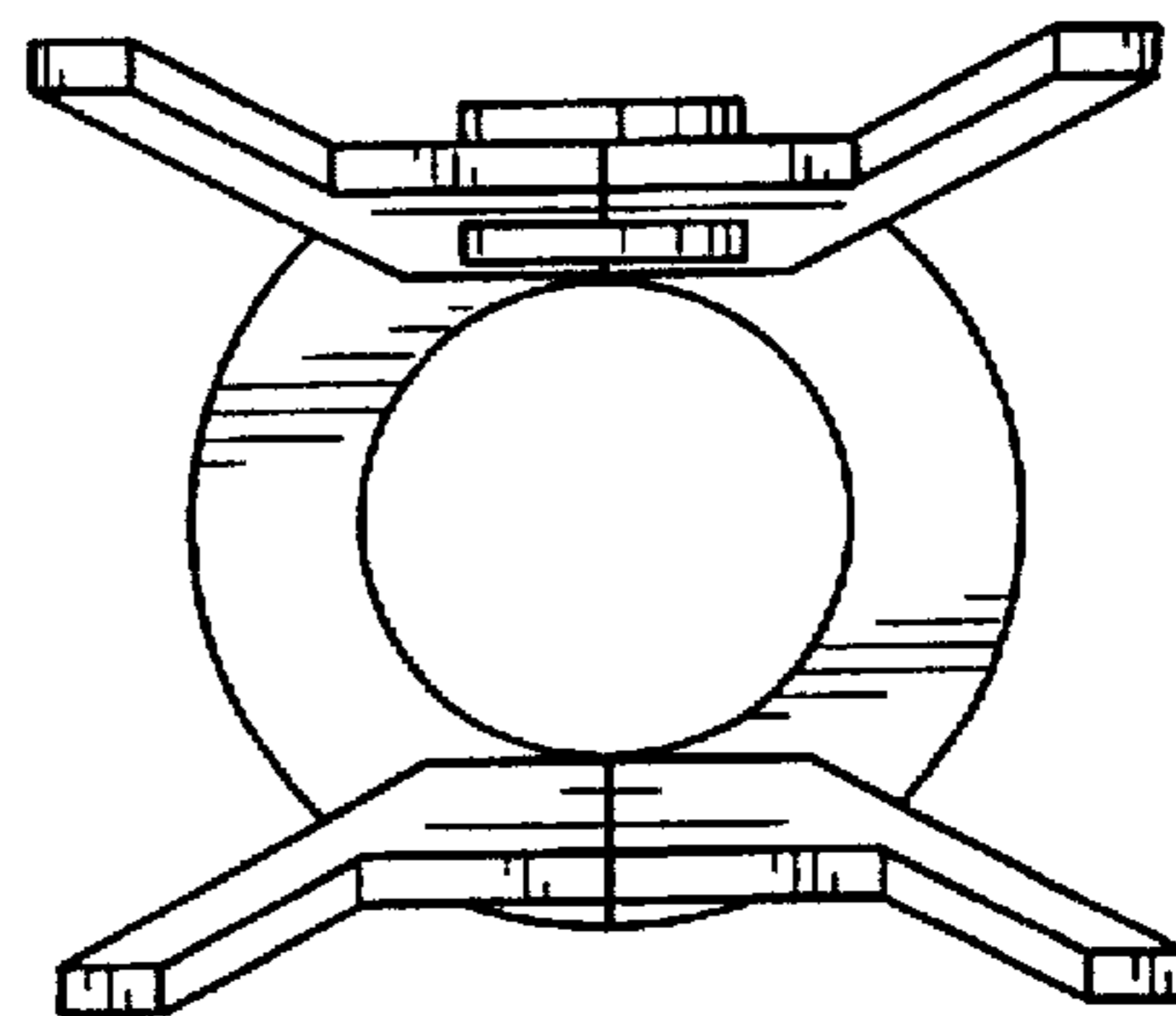

FIG. 5