

US00D389233S

United States Patent [19]

Smith et al.

[11] Patent Number: Des. 389,233

[45] Date of Patent: **Jan. 13, 1998

[54] AUTOMOTIVE AROMATHERAPY DIFFUSER

[76] Inventors: Jeffrey Lynn Smith, 805 W. Depot Ave., Apt. B; Brad Claude Koelblinger, 1302 Little Fawn, both of Fairfield, Iowa 52556

[**] Term: 14 Years

[21] Appl. No.: 63,960

[22] Filed: Dec. 19, 1996

[51] LOC (6) Cl. 23-04

[52] U.S. Cl. D23/367; D23/366

[58] Field of Search D23/366-369; 392/390, 403; 261/DIG. 65; D10/116, 119

[56] References Cited

U.S. PATENT DOCUMENTS

2,898,649	8/1959	Murray	422/125
5,373,581	12/1994	Smith	392/390
5,394,506	2/1995	Stein et al.	392/390

FOREIGN PATENT DOCUMENTS

2626452	8/1989	France	239/57
---------	--------	--------	--------

OTHER PUBLICATIONS

Rain-Maker Manufacturing, Adv., Plug (A), right side of page.

Primary Examiner—Lisa Lichtenstein

Attorney, Agent, or Firm—Zarley, McKee, Thomte, Voorhess & Sease

[57] CLAIM

The ornamental design for an automotive aromatherapy diffuser, as shown and described.

DESCRIPTION

FIG. 1 is a bottom perspective view of a automotive aromatherapy diffuser showing our new design;

FIG. 2 is a bottom plan view thereof;

FIG. 3 is a top plan view thereof;

FIG. 4 is a typical side elevational view thereof;

FIG. 5 is a rear elevational view thereof;

FIG. 6 is a front elevational view thereof;

FIG. 7 is an enlarged scale bottom perspective view of the cap for an automotive aroma therapy diffuser shown separately for clarity of illustration;

FIG. 8 is a bottom plan view thereof;

FIG. 9 is a top plan view thereof;

FIG. 10 is a typical side elevational view thereof;

FIG. 11 is a rear elevational view thereof; and,

FIG. 12 is a front elevational view thereof.

The cross-hatching represents conventional fabric and is understood to extend uniformly throughout the areas represented.

1 Claim, 2 Drawing Sheets

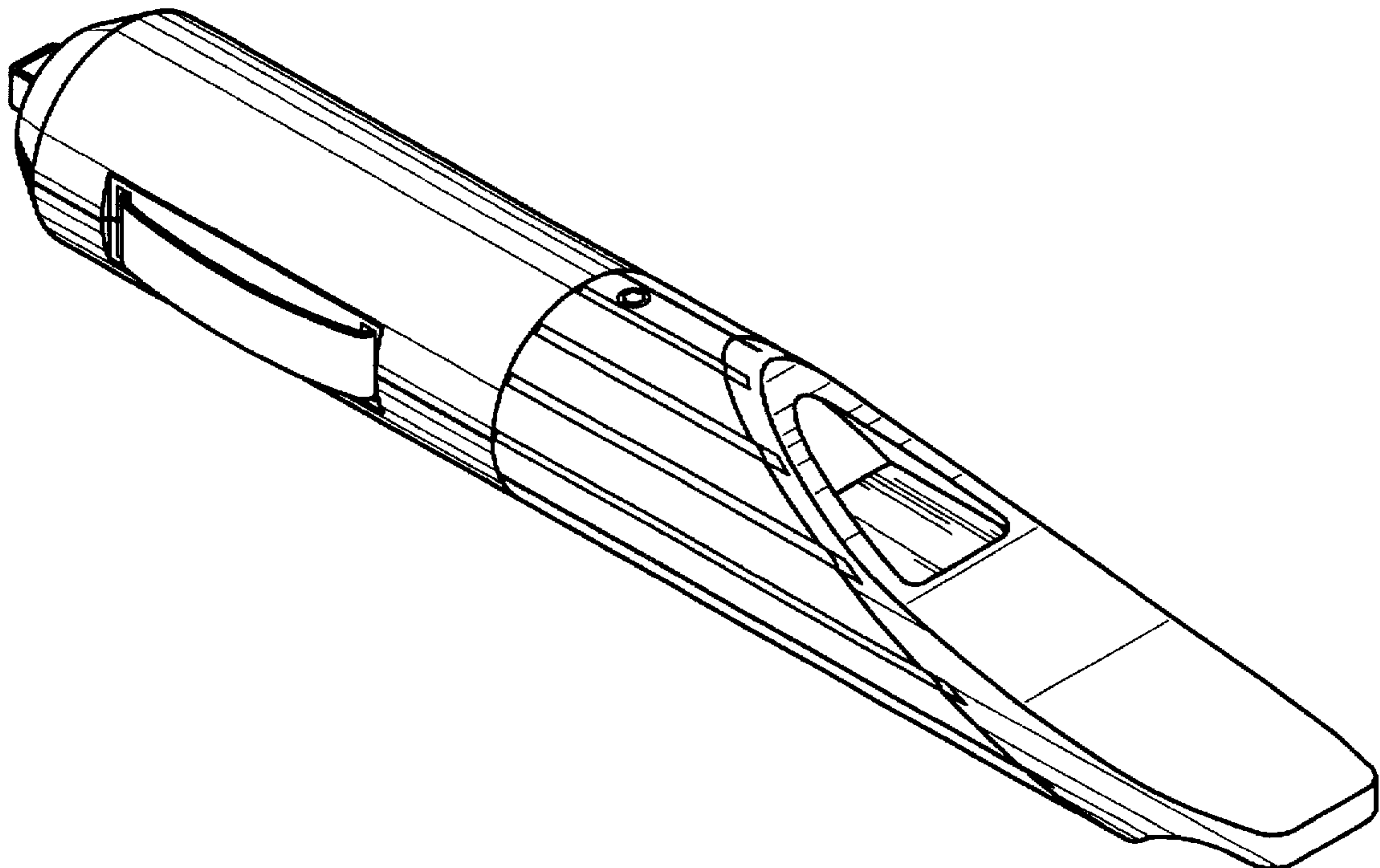

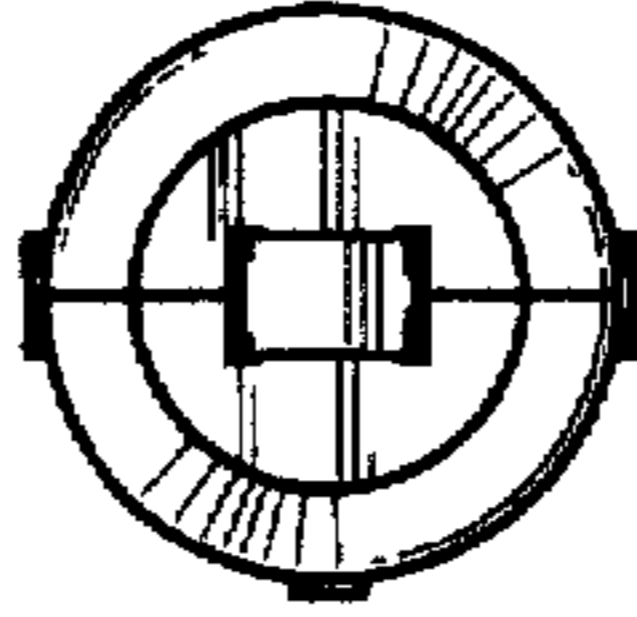
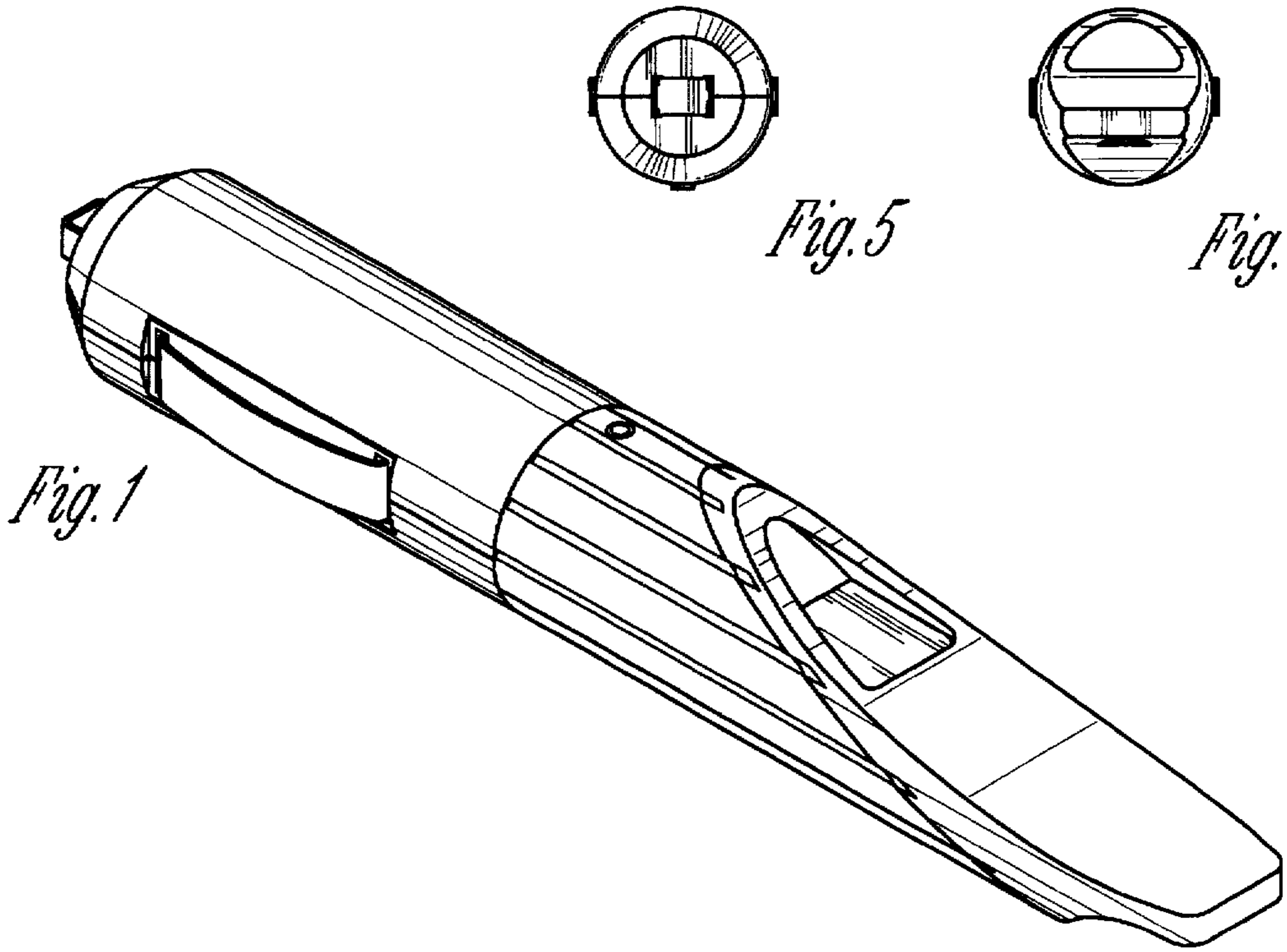

Fig. 5

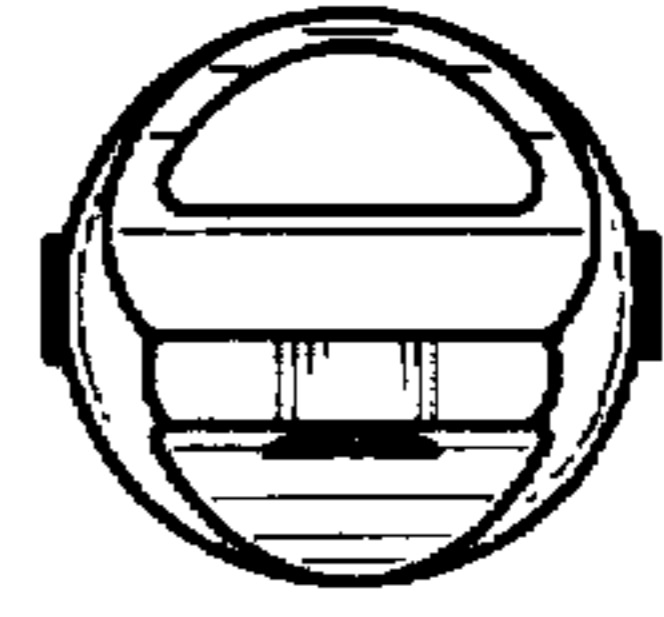

Fig. 6

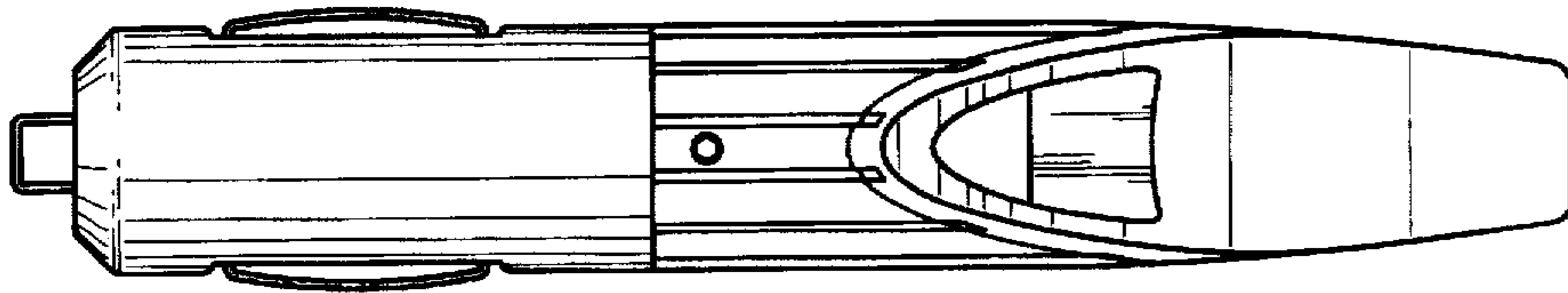

Fig. 2

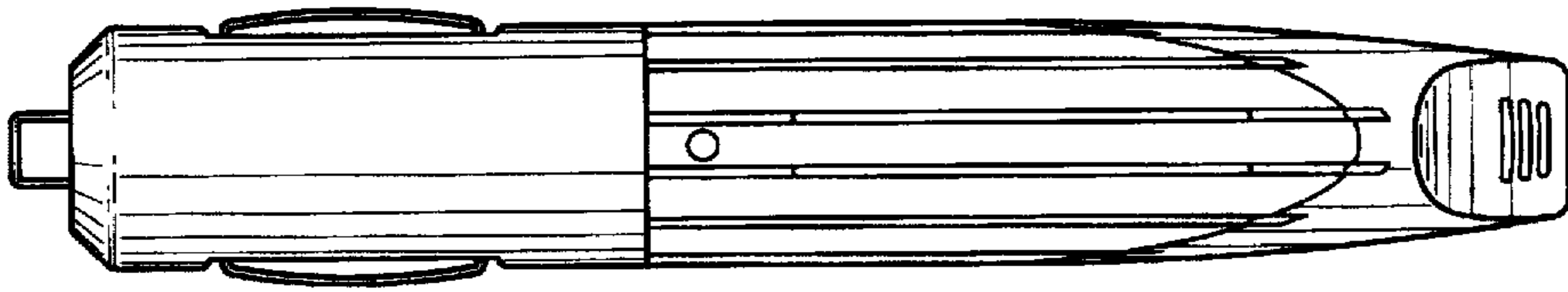

Fig. 3

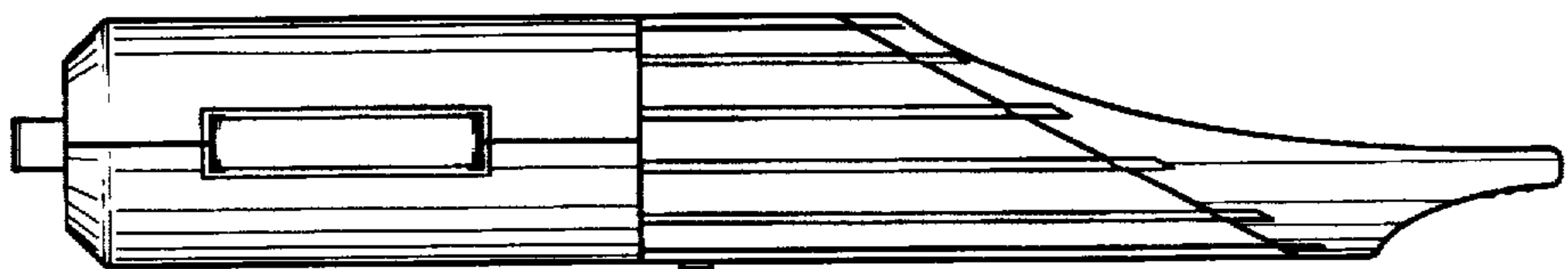

Fig. 4

