



US00D389093S

**United States Patent** [19]  
**Bomgardner**

[11] **Patent Number: Des. 389,093**  
[45] **Date of Patent: \*\*Jan. 13, 1998**

[54] **RAILCAR HYDRAULIC SHOCK ABSORBER  
BACKSTOP**

3,910,418 10/1975 Hawthorne ..... 213/8  
4,480,758 11/1984 Hurt ..... 213/7 X

[75] Inventor: **Charles T. Bomgardner**, Burleson,  
Tex.

**OTHER PUBLICATIONS**

FMI Drawing 15340 Hydraulic Cushioning Device; Jun. 7,  
1993.

[73] Assignee: **FM Industries, Inc.**, Fort Worth, Tex.

FMI Drawing 8-87-15306 Casting-Backstop and Buffstop;  
Jun. 10, 1976.

[\*\*] Term: **14 Years**

*Primary Examiner*—Nelson C. Holtje  
*Attorney, Agent, or Firm*—James E. Bradley

[21] Appl. No.: **64,745**

[57] **CLAIM**

[22] Filed: **Jan. 9, 1997**

The ornamental design for a railcar hydraulic shock absorber  
backstop, as shown.

[51] LOC (6) Cl. .... **12-03**

[52] U.S. Cl. .... **D12/48; D12/42**

[58] Field of Search ..... D12/48, 42; 213/7-8,  
213/10, 43, 223

**DESCRIPTION**

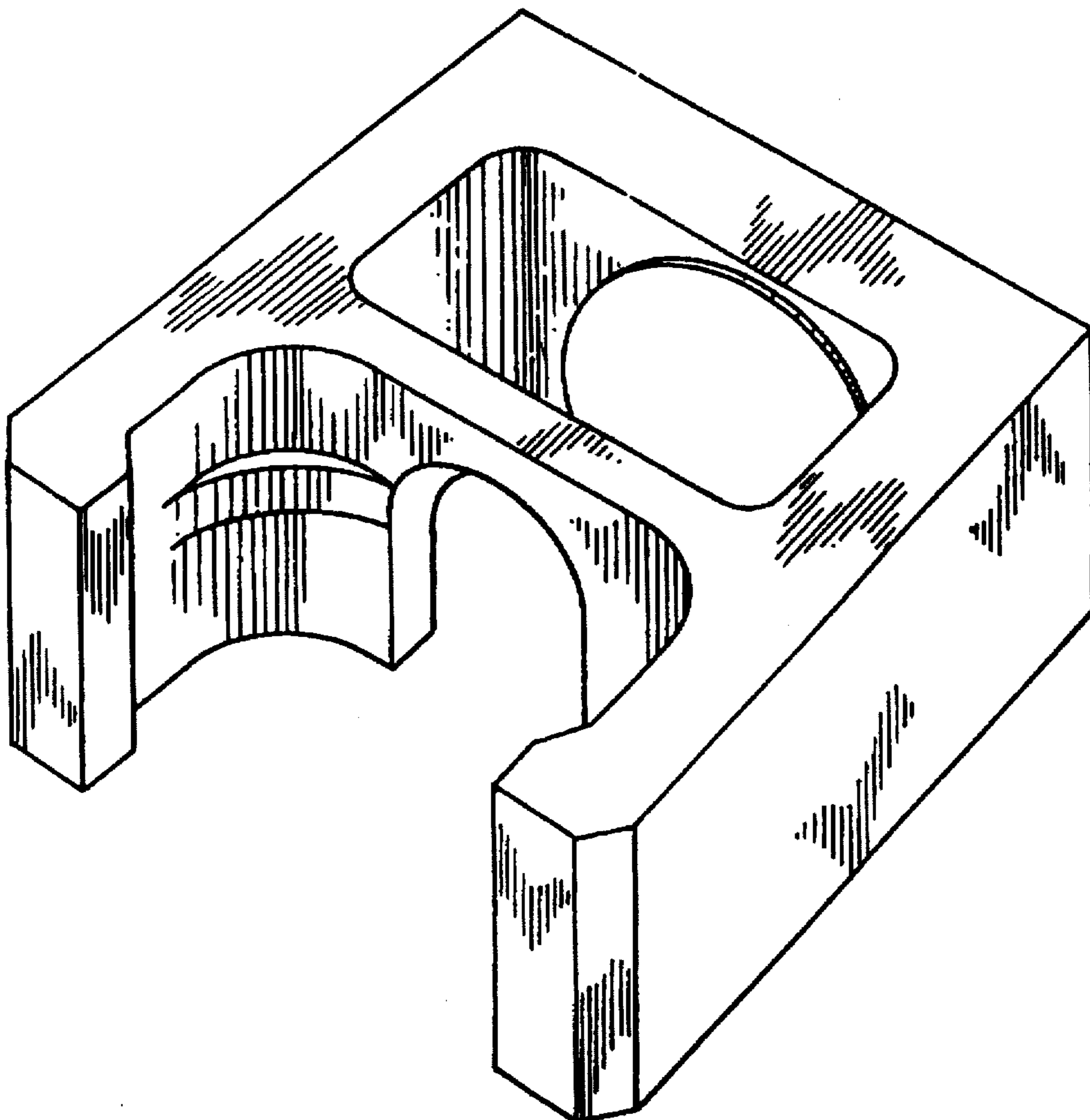
FIG. 1 is a perspective view a railway car hydraulic shock  
absorber backstop showing my new design;  
FIG. 2 is a bottom perspective view thereof;  
FIG. 3 is another top perspective thereof, showing a right  
side; and,  
FIG. 4 is a top plan view thereof.

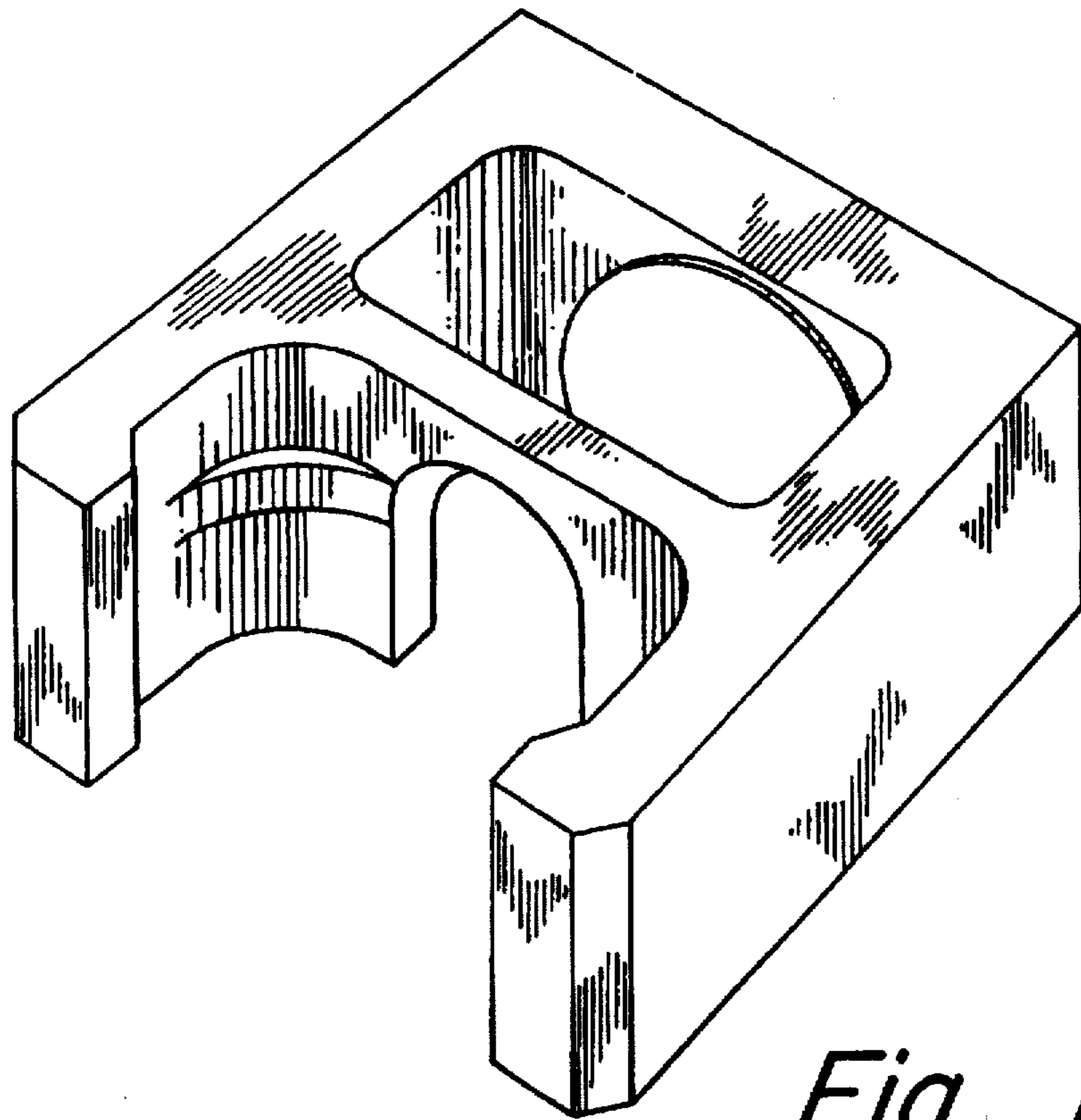
[56] **References Cited**

**U.S. PATENT DOCUMENTS**

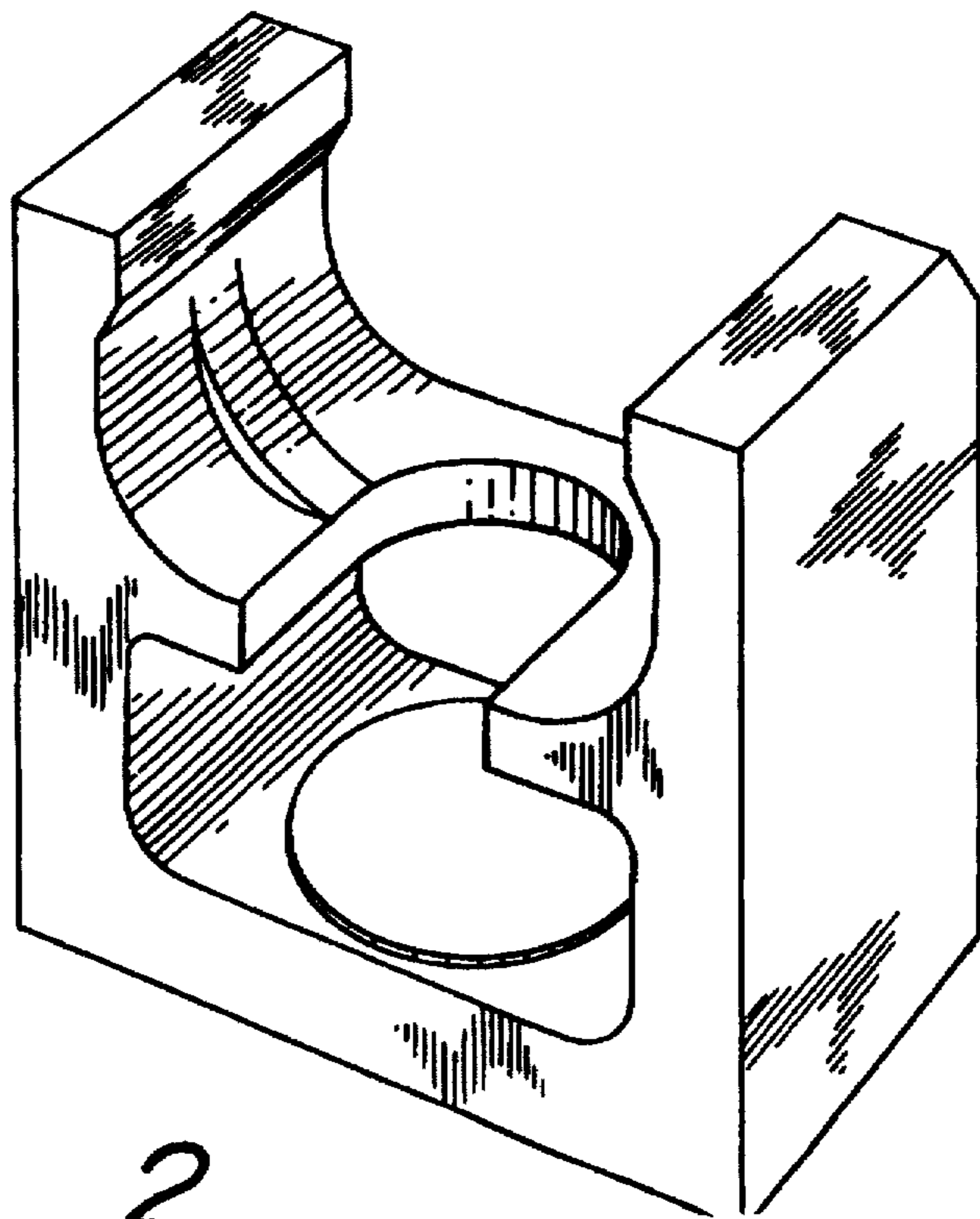
D. 26,941	4/1897	Vissering	.....	D12/48
D. 27,219	6/1897	Galbraith	.....	D12/48
D. 51,531	11/1917	Neikirk	.....	D12/48
3,836,013	9/1974	Hawthorn	.....	213/43 X
3,854,596	12/1974	Stephenson	.....	213/8

**1 Claim, 2 Drawing Sheets**

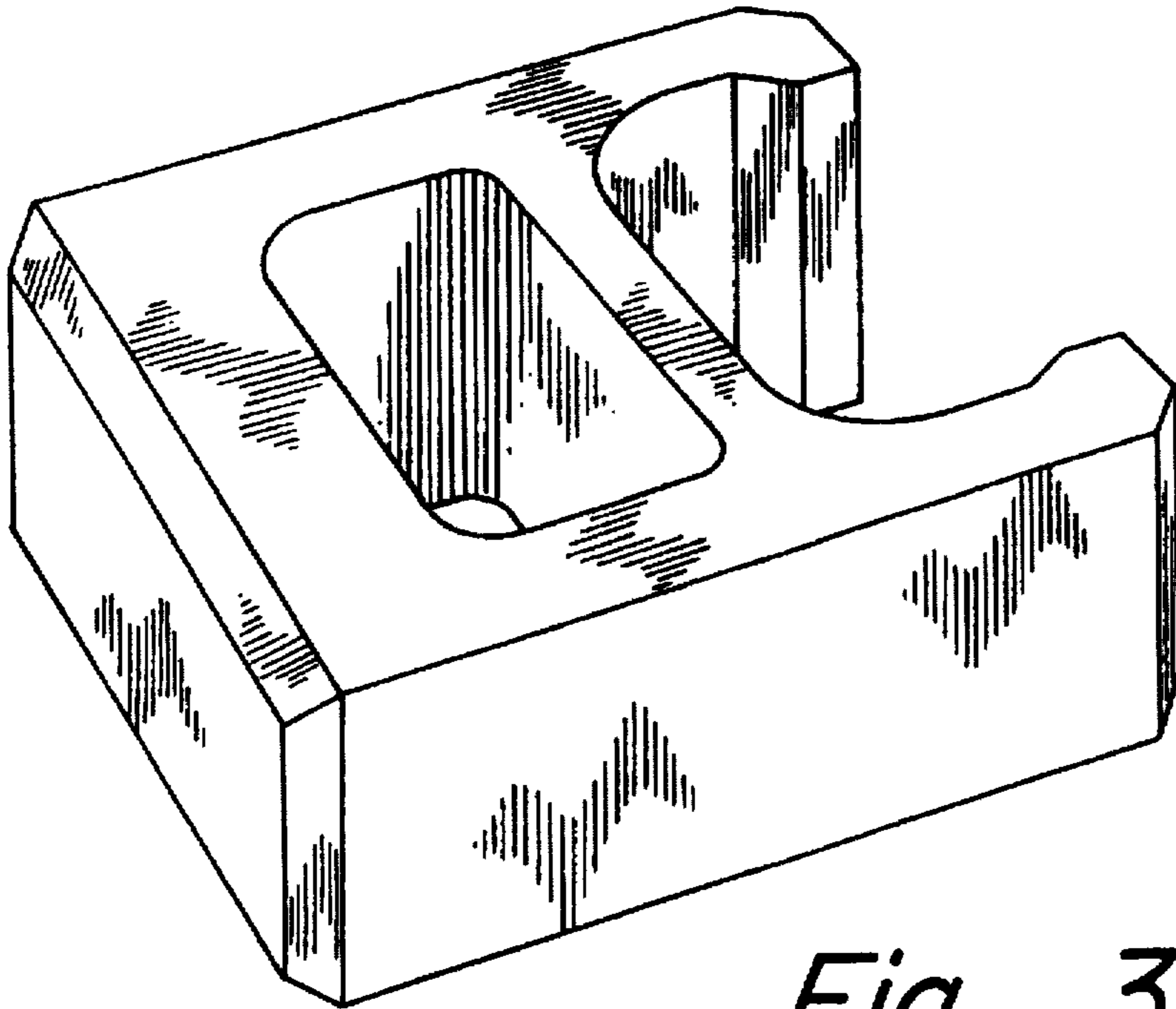




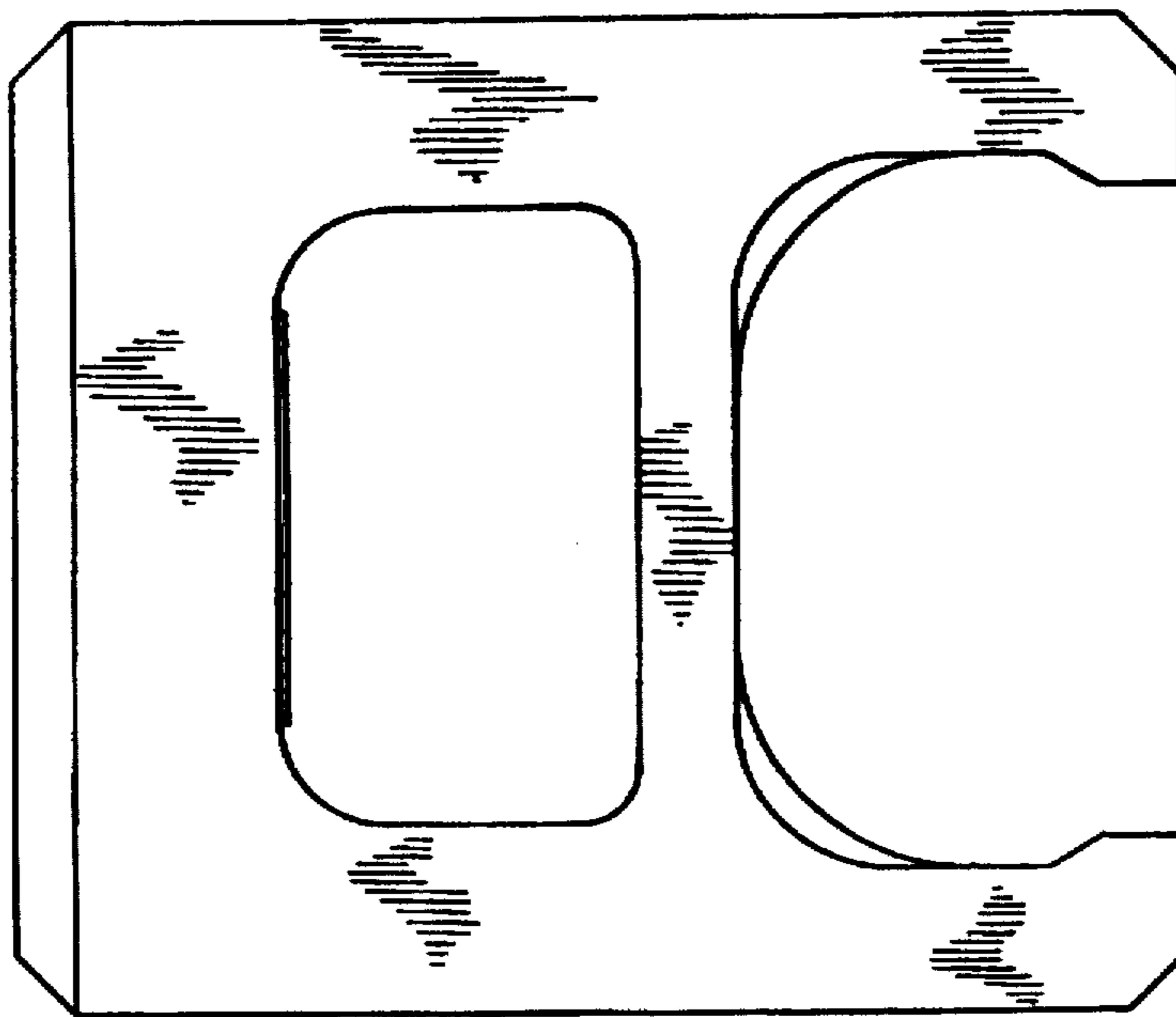
*Fig. 1*



*Fig. 2*



*Fig. 3*



*Fig. 4*