



US00D389002S

United States Patent [19]

Demore et al.

[11] Patent Number: **Des. 389,002**

[45] Date of Patent: ****Jan. 13, 1998**

[54] **WATER DISPENSER**

[75] Inventors: **Anthony Demore, Copley; Patrick Douglas, Medina, both of Ohio**

[73] Assignee: **Rubbermaid Incorporated, Wooster, Ohio**

[**] Term: **14 Years**

[21] Appl. No.: **62,262**

[22] Filed: **Nov. 12, 1996**

[51] LOC (6) Cl. **07-01**

[52] U.S. Cl. **D7/313; D7/306; D7/300**

[58] Field of Search **D7/306, 300, 307, D7/308, 312, 322, 311, 587, 570, 304, 313; 222/185; D23/212, 209; D9/527**

[56] **References Cited**

U.S. PATENT DOCUMENTS

D. 249,701	9/1978	Maples et al.	D7/313	X
D. 278,200	4/1985	Dahlberg	D23/209	X
D. 278,650	4/1985	Slovak et al.	D23/209	
D. 283,044	3/1986	Jack	D23/209	
D. 318,395	7/1991	Juergens	D7/311	
D. 349,417	8/1994	Malmberg et al.	D7/300	X
D. 366,387	1/1996	Malmberg et al.	D7/313	
D. 366,391	1/1996	Haley et al.	D7/397	

OTHER PUBLICATIONS

Pp. 2, 5 and 11, Water dispensers; Dispensing Innovation, 5160 Commerce Drive, Baldwin Park, California 91706. Published at least as early as May, 1994.

Packaging, Water dispenser; Brita (USA) Inc., 1221 Broadway, Oakland, California 94612. Publication date 1994.

Packaging, Water dispenser; Brita (USA) Inc., 1221 Broadway, Oakland, California 94612. Published at least as early as Apr., 1996.

P. 17, Beverage dispenser; Rubbermaid Commercial Products, Inc., 3124 Valley Avenue, Winchester, Virginia 22601. Publication date 1989.

Primary Examiner—M. N. Pandozzi

Attorney, Agent, or Firm—Richard B. O'Planick; Lisa B. Riedesel

[57] **CLAIM**

The ornamental design for a water dispenser, as shown and described.

DESCRIPTION

FIG. 1 is a top right front perspective view of a water dispenser showing our new design;

FIG. 2 is a right side elevational view thereof; the left side elevational view being a mirror image;

FIG. 3 is a top plan view thereof;

FIG. 4 is a rear elevational view thereof;

FIG. 5 is a front elevational view thereof; and,

FIG. 6 is a bottom plan view thereof.

1 Claim, 6 Drawing Sheets

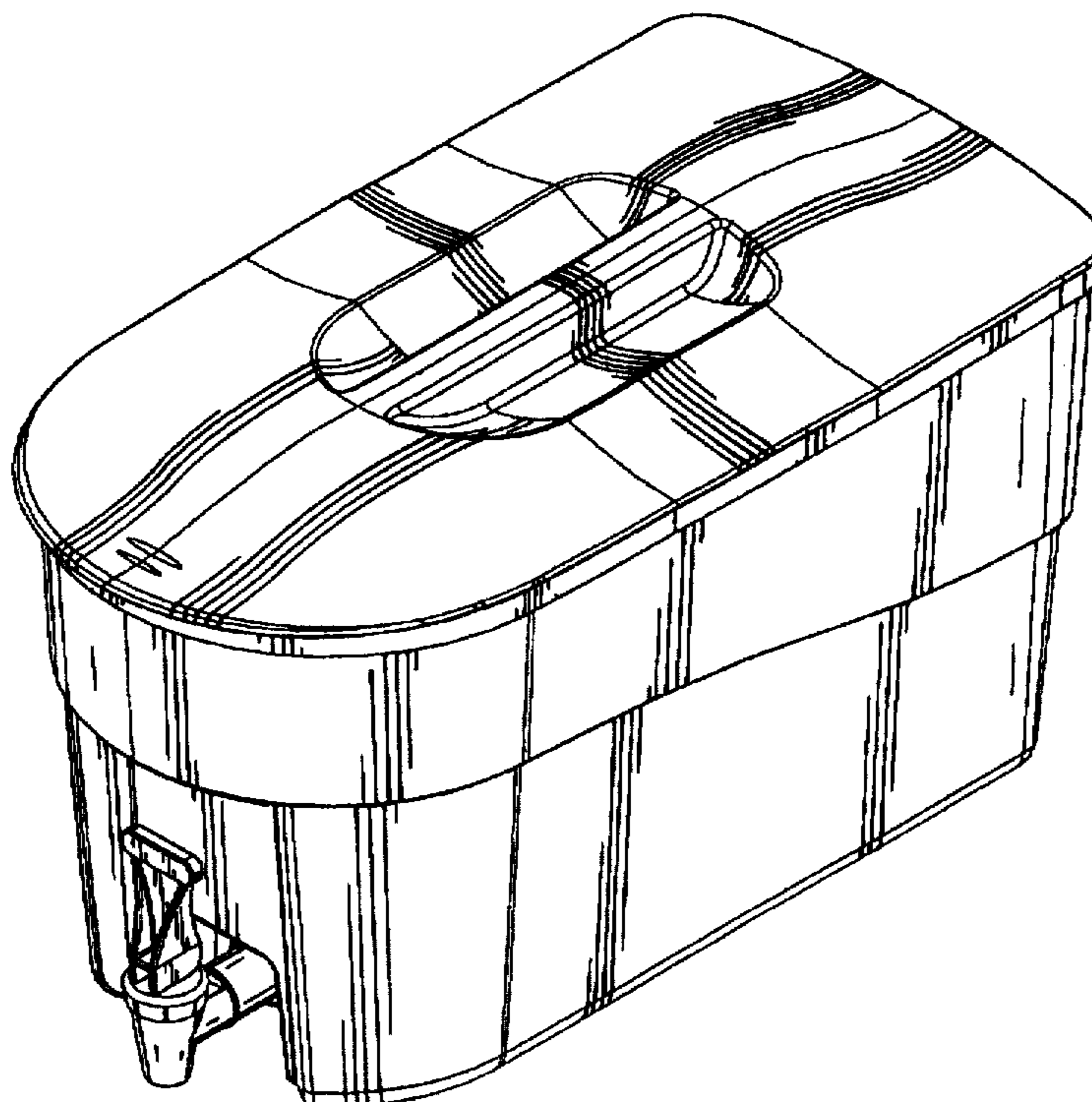

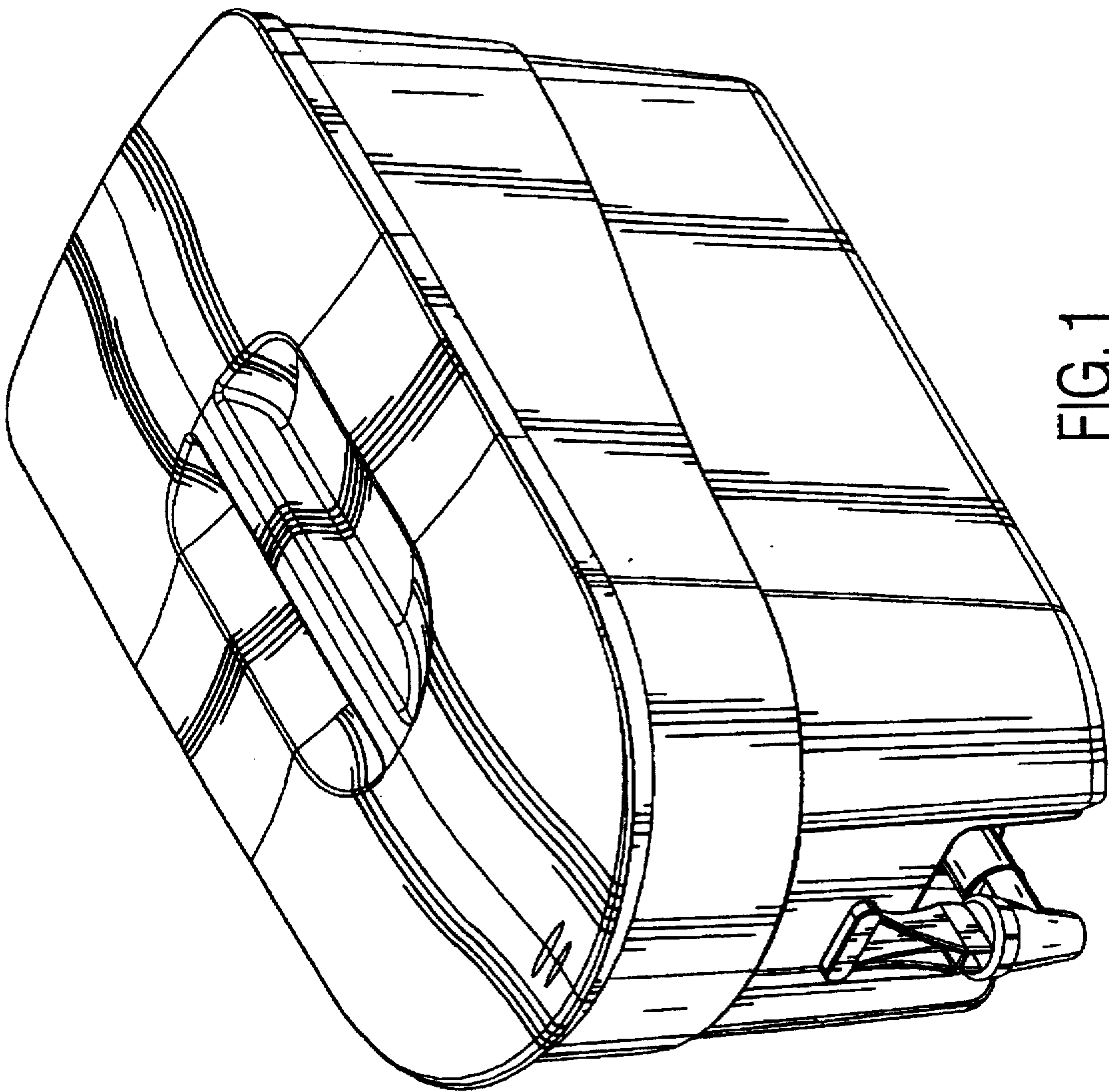

FIG. 1

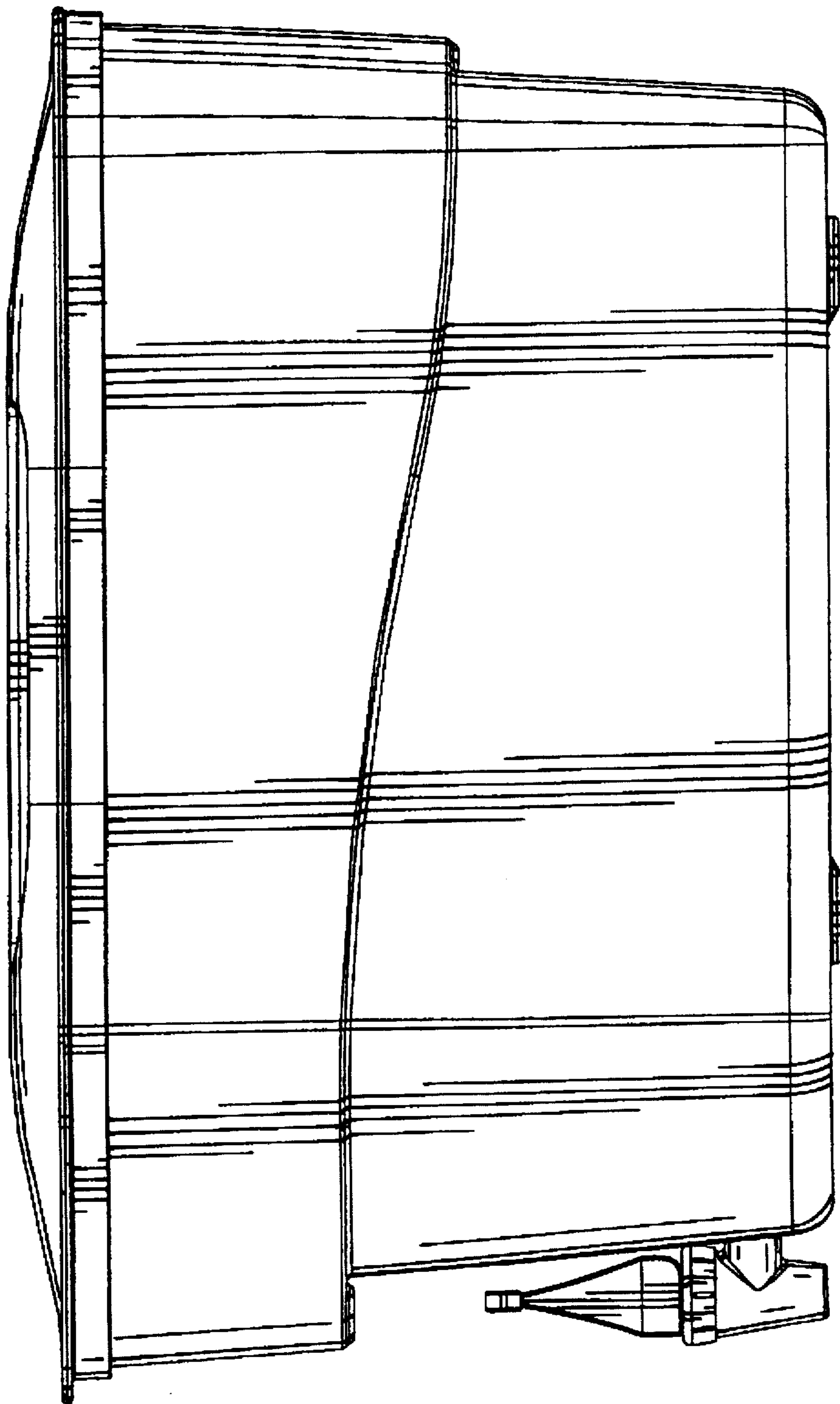

FIG. 2

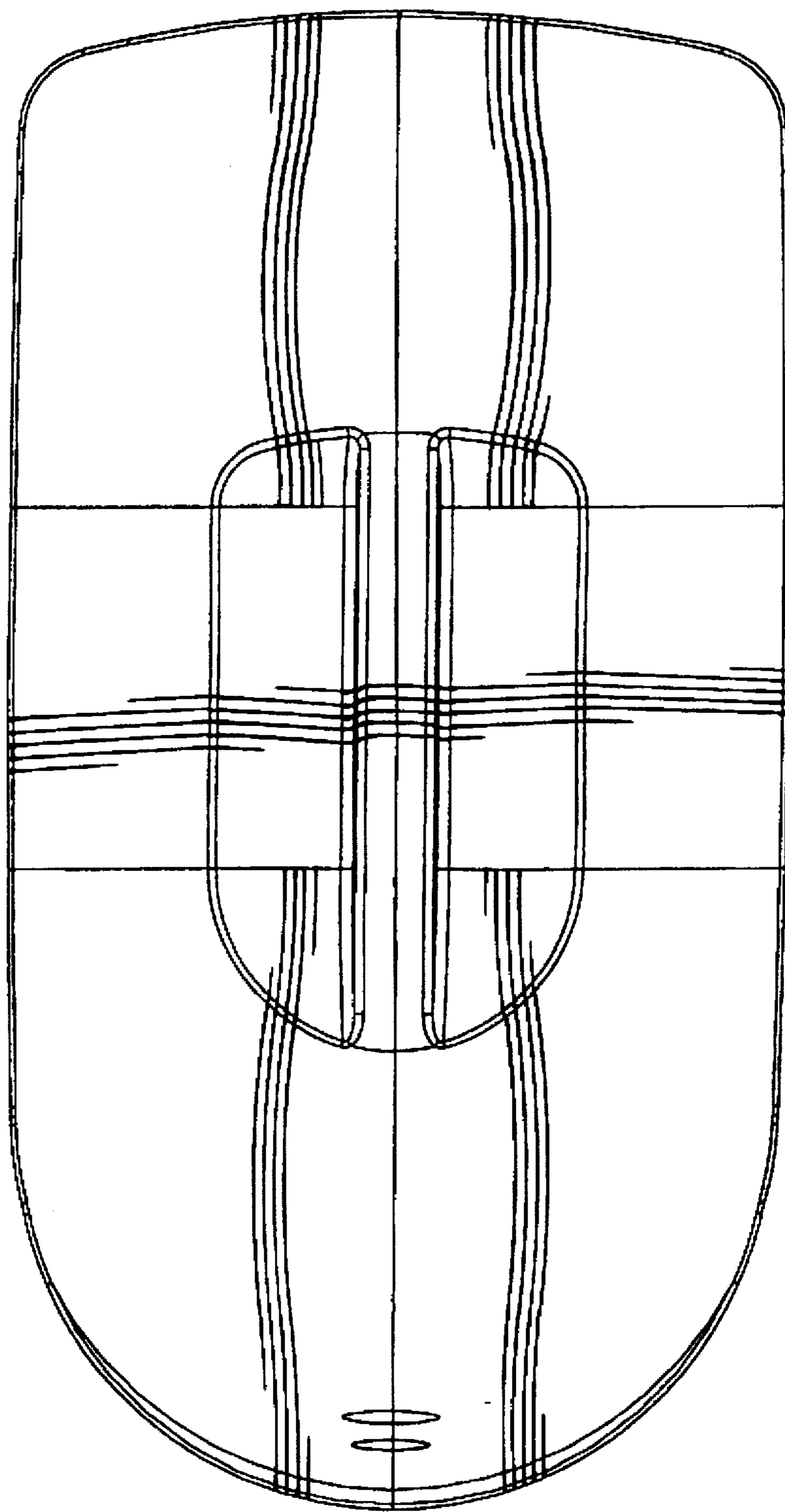

FIG. 3

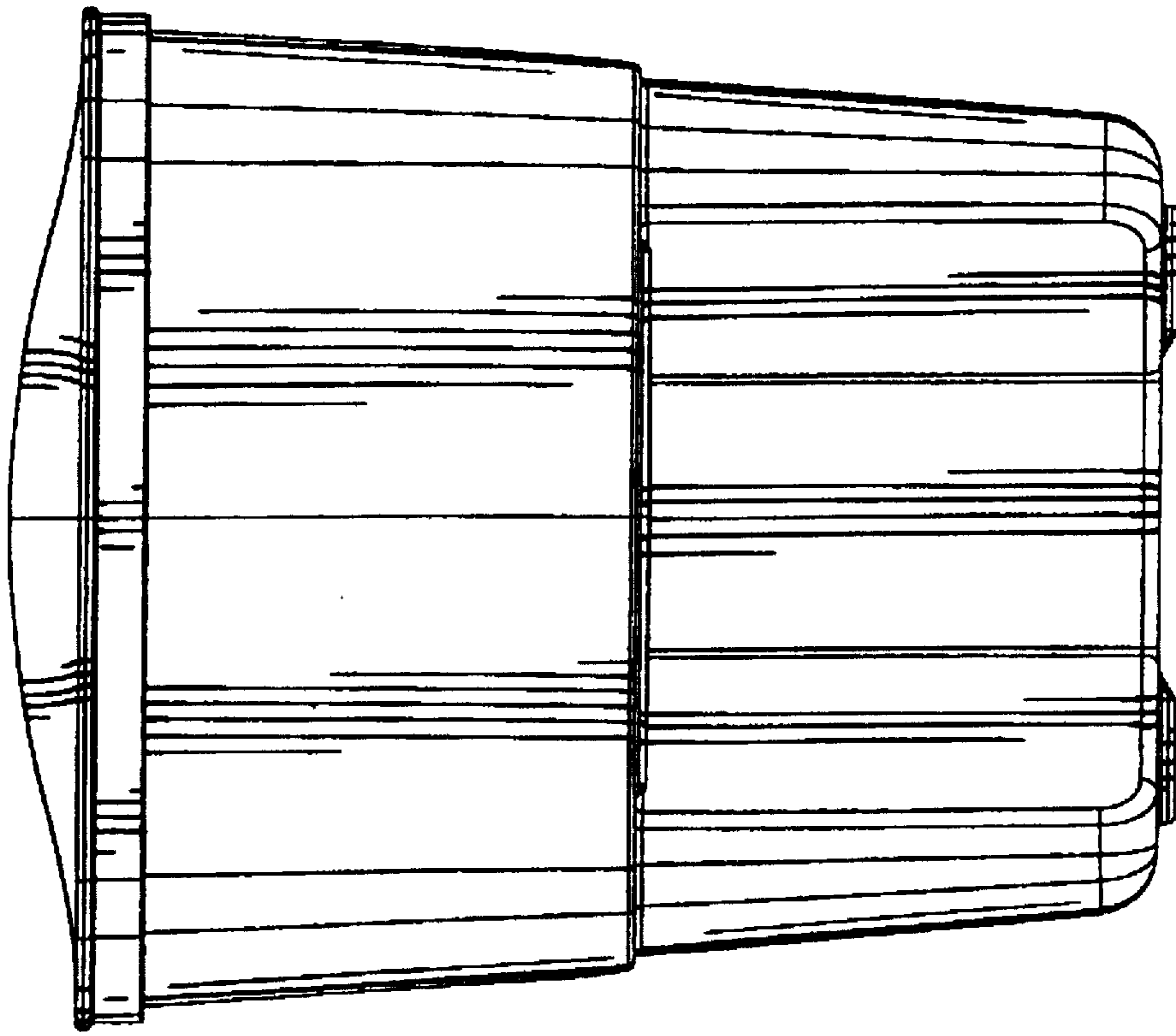

FIG. 4

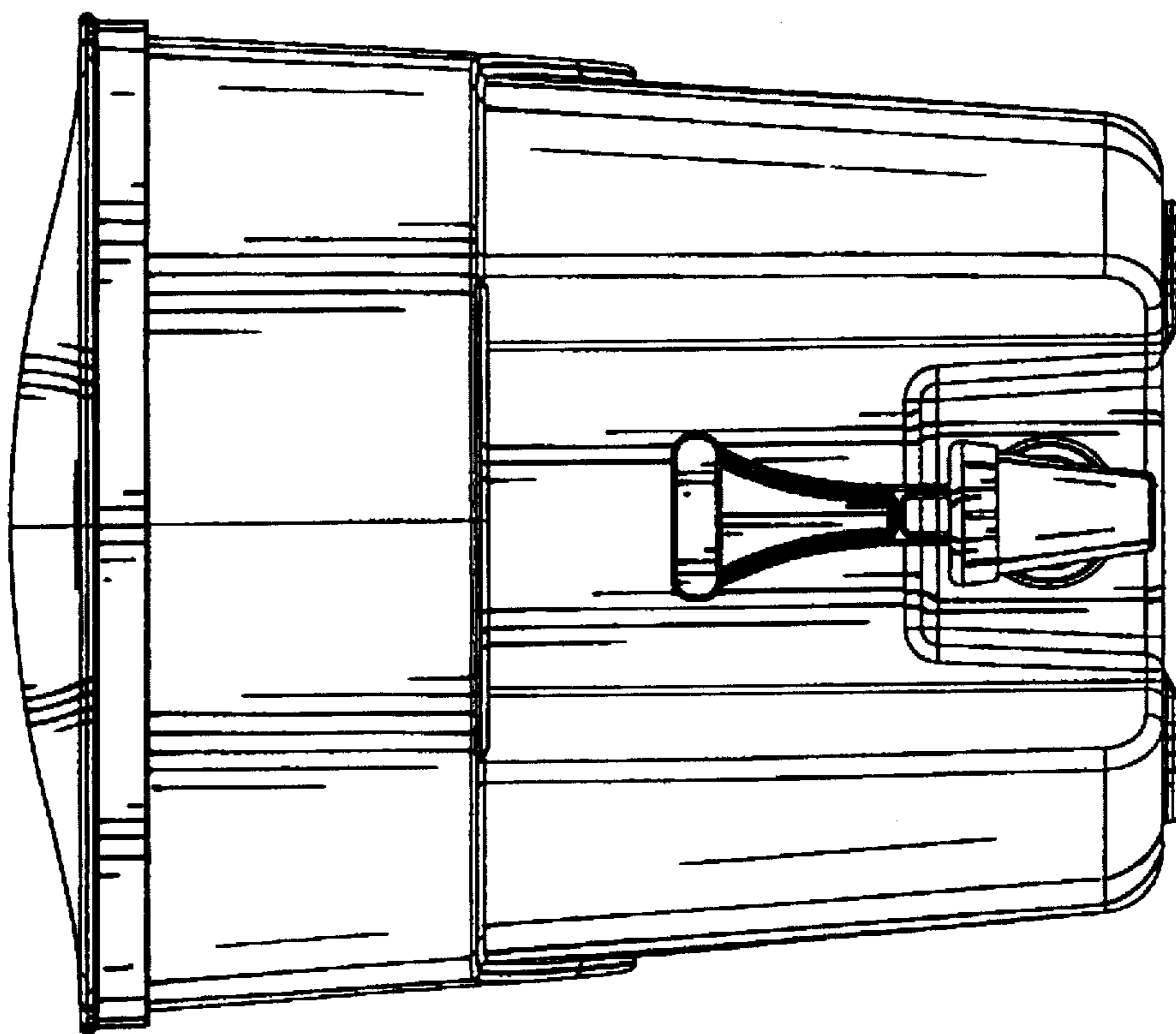

FIG. 5

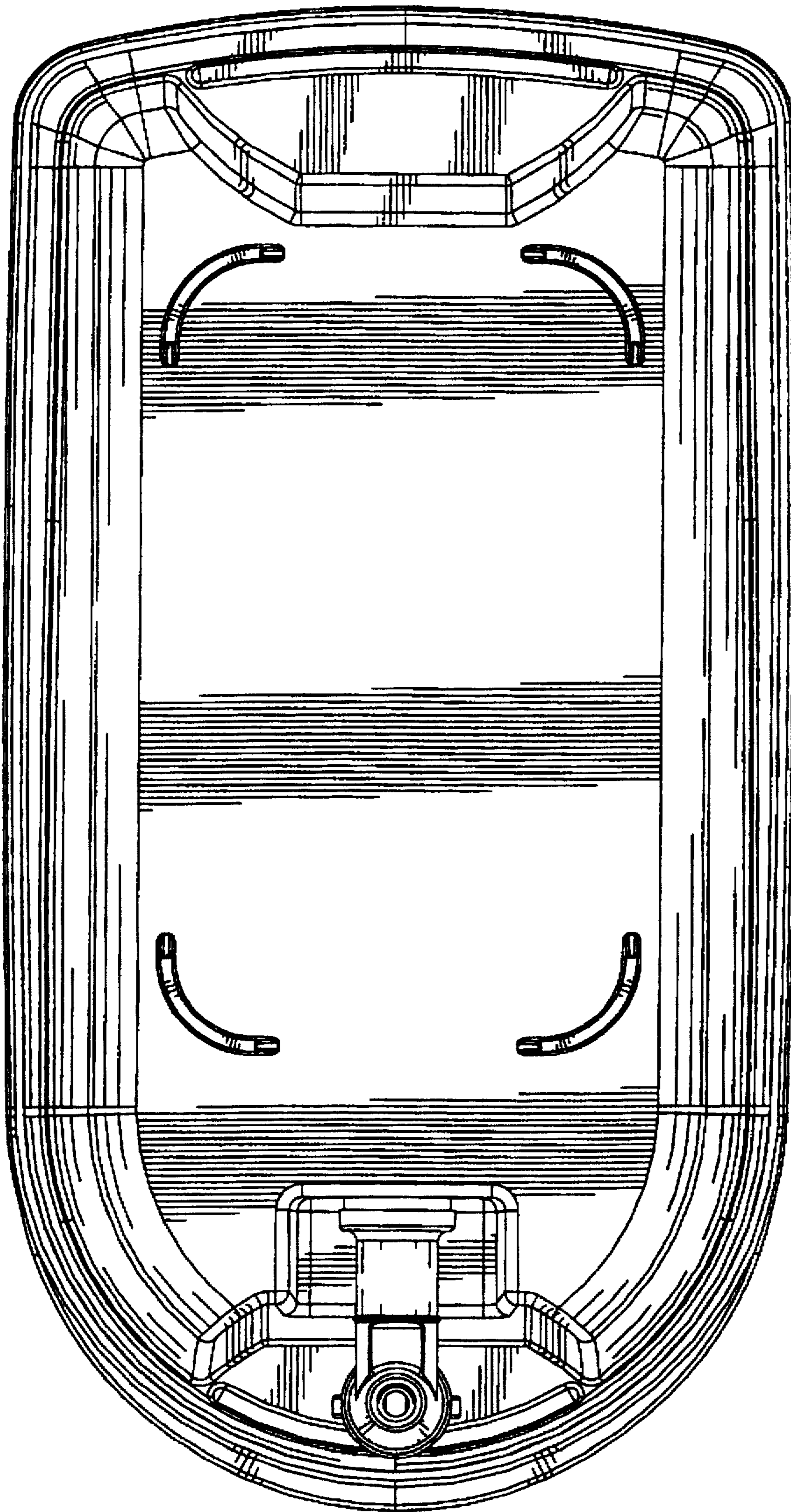

FIG. 6