

US00D388262S

United States Patent [19]

[11] Patent Number: Des. 388,262

Benting et al.

[45] Date of Patent: **Dec. 30, 1997

[54] MUSIC STAND

[75] Inventors: Gary M. Benting, Owatonna; Eric J. Mueller; Cindy Weber, both of Minneapolis, all of Minn.

[73] Assignee: Wenger Corporation, Owatonna, Minn.

[**] Term: 14 Years

[21] Appl. No.: 54,329

[22] Filed: May 9, 1996

[51] LOC (6) Cl. 06-04

[52] U.S. Cl. D6/419; D17/99

[58] Field of Search D6/419, 420, 396, D6/429-431; 248/441.1, 446, 447, 448, 454, 455, 460, 451; D17/99

[56] **References Cited**

U.S. PATENT DOCUMENTS

D. 186,895	12/1959	Wenger	D6/419
D. 187,030	1/1960	Wenger	D6/419
D. 263,361	3/1982	Johnson et al.	.	
D. 314,873	2/1991	Wenger et al.	.	
568,139	9/1896	Haynes	.	
856,679	6/1907	Buckland	.	
2,799,968	7/1957	Wythe	.	

3,637,172	1/1972	Diesbach	248/460
4,312,490	1/1982	Biasini	248/441.1 X
4,360,183	11/1982	Biasini	248/451
4,650,145	3/1987	Natzel et al.	.	
4,671,479	6/1987	Johnson et al.	.	
4,819,902	4/1989	Wenger et al.	.	
5,356,109	10/1994	Biasini	248/448

FOREIGN PATENT DOCUMENTS

120539	5/1901	Germany	.
53740	2/1911	Switzerland	.
20550	9/1911	United Kingdom	.

Primary Examiner—Carmen H. Vales-Lado
Attorney, Agent, or Firm—Patterson & Keough, P.A.

[57] **CLAIM**

The ornamental design for a music stand, as shown and described.

DESCRIPTION

FIG. 1 is a front perspective view of a music stand showing our design;
FIG. 2 is a top plan view;
FIG. 3 is a bottom plan view;
FIG. 4 is a front elevational view;
FIG. 5 is a rear elevational view; and,
FIG. 6 is a side elevational view thereof.

1 Claim, 2 Drawing Sheets

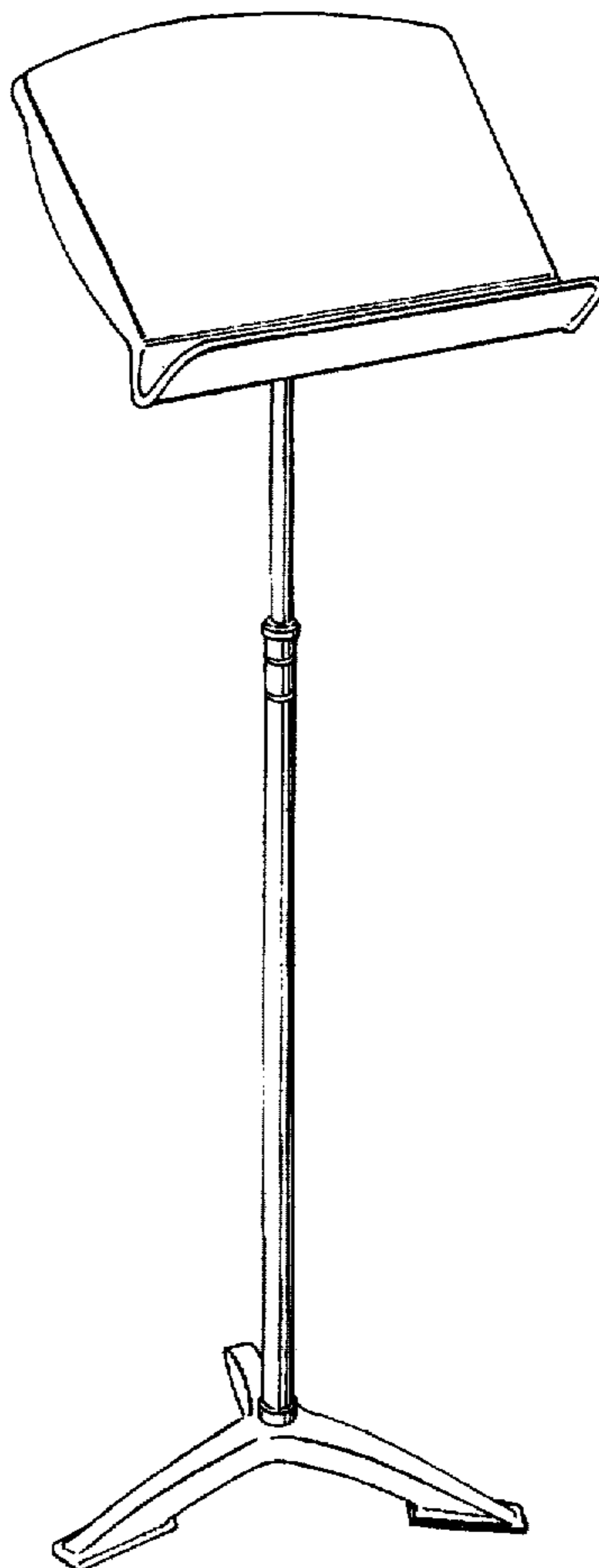

Fig.1

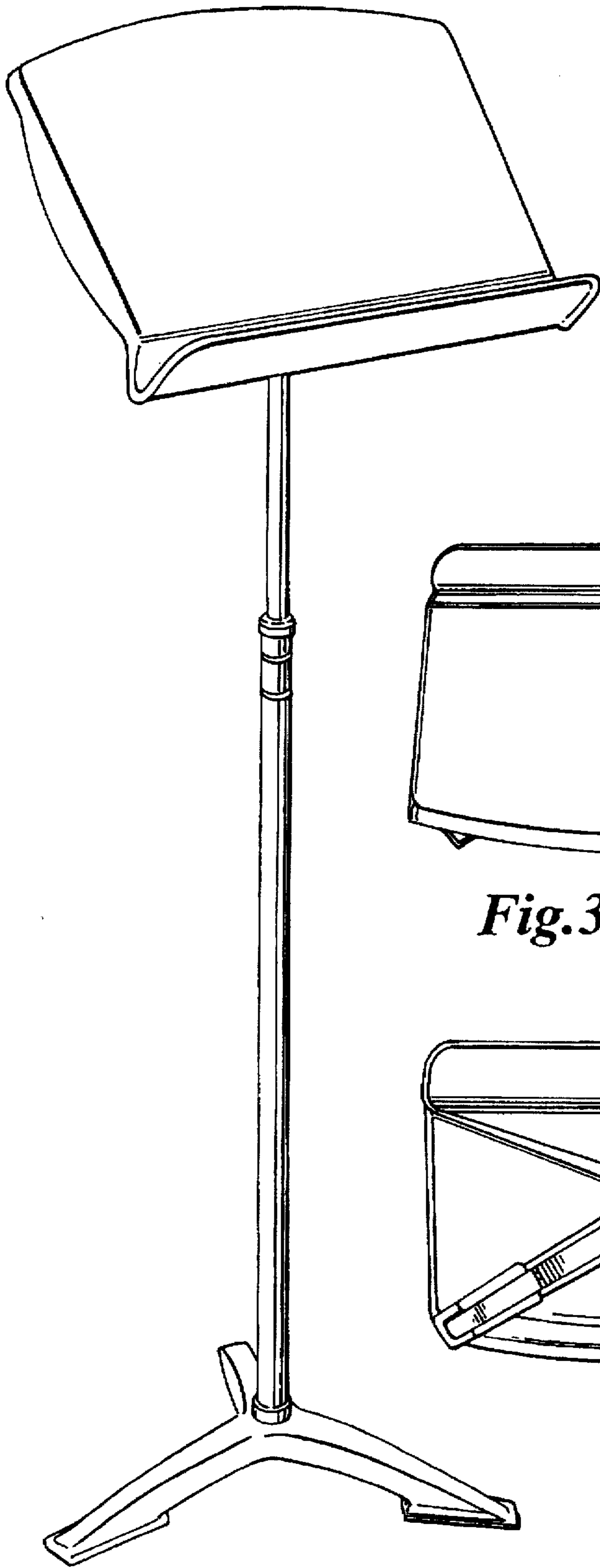

Fig.2

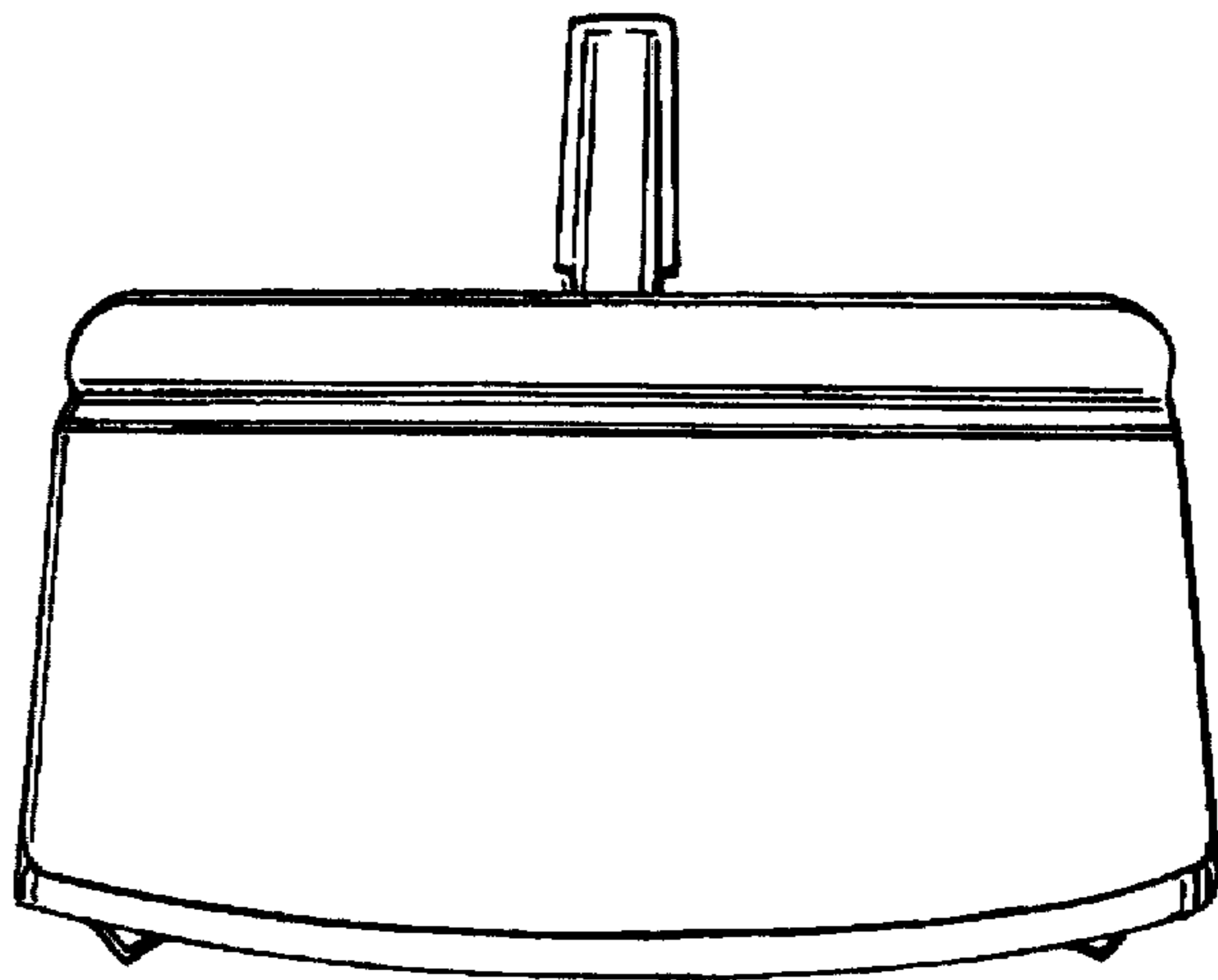

Fig.3

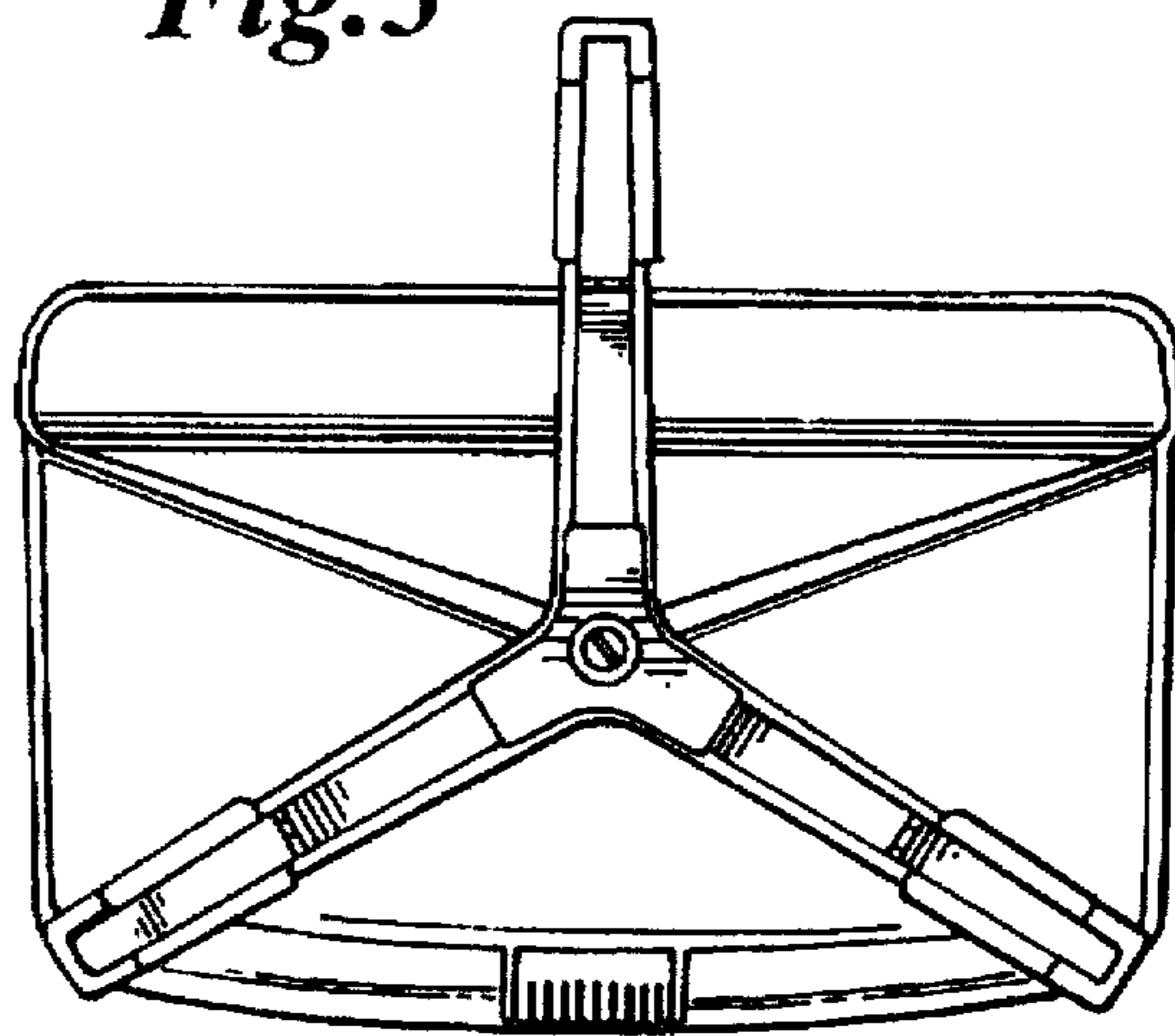

Fig.4

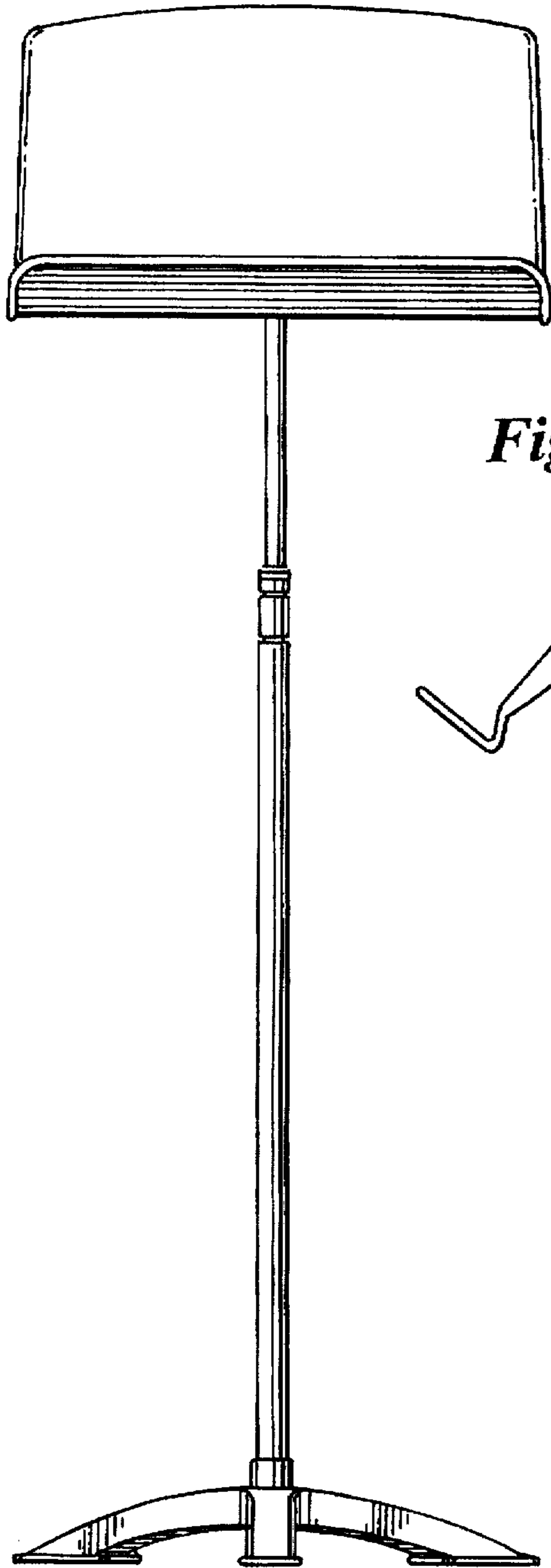

Fig.5

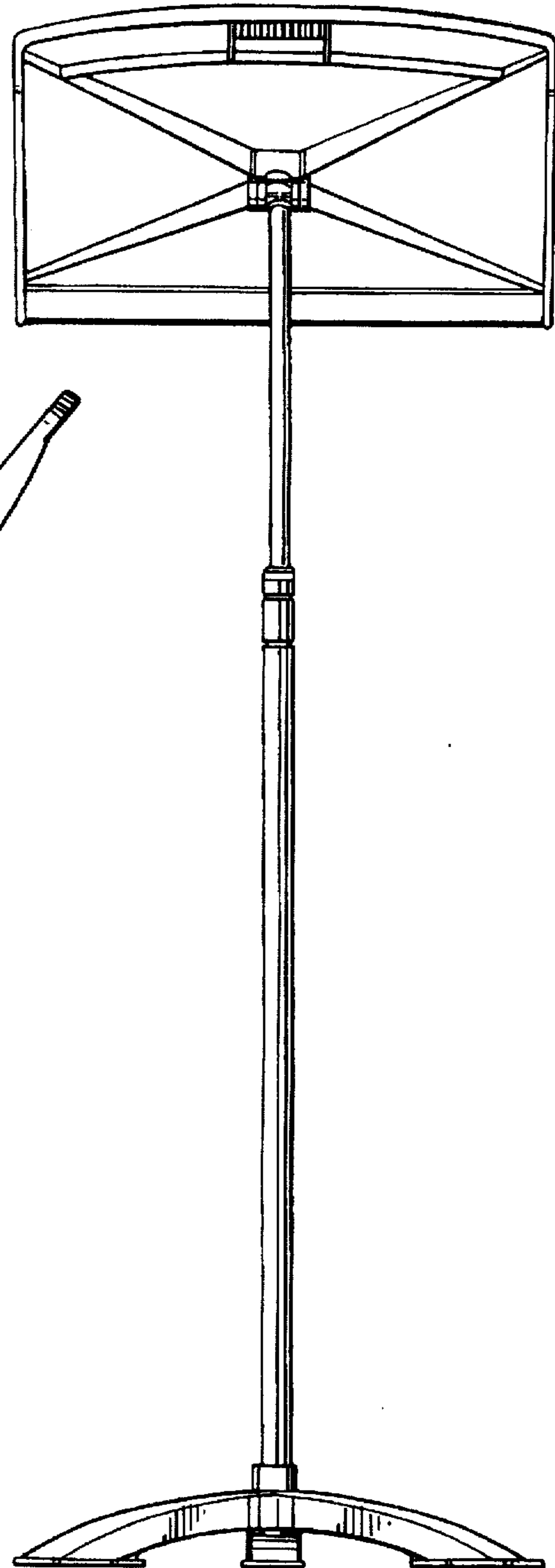

Fig.6

