



US00D388097S

# United States Patent [19]

Yamakawa et al.

[11] Patent Number: Des. 388,097

[45] Date of Patent: \*\*Dec. 23, 1997

[54] ANTENNA FOR AN AUTOMOBILE

[75] Inventors: **Katsubiko Yamakawa**, Tokyo; **Shigeru Uchino**, Yokohama, both of Japan

[73] Assignee: **Harada Industry Co., Ltd.**, Tokyo, Japan

[\*\*] Term: 14 Years

[21] Appl. No.: 57,824

[22] Filed: Aug. 1, 1996

[30] Foreign Application Priority Data

Feb. 5, 1996 [JP] Japan ..... 8-2712

[51] LOC (6) Cl. .... 14-03

[52] U.S. Cl. .... D14/230

[58] Field of Search ..... D14/230-238; D8/380; 343/702, 713, 715, 792.5, 795, 840

[56] References Cited

### U.S. PATENT DOCUMENTS

D. 105,067	6/1937	Williams	.....	D14/234
D. 199,373	10/1964	Alissandratos	.....	D8/380
D. 310,670	9/1990	Sheriff	.....	D14/230
D. 329,240	9/1992	Cooper	.....	D14/230
D. 332,738	1/1993	Bloom	.....	D8/380
2,361,953	11/1944	McDonald, Jr.	.....	343/702
3,050,730	8/1962	Lamberty	.....	343/792.5
3,599,214	8/1971	Altmayer	.....	343/713

4,253,099	2/1981	Yamazaki et al.	.....	343/713
4,940,991	7/1990	Sheriff	.....	343/795
5,255,002	10/1993	Day	.....	343/713
5,264,858	11/1993	Shiina	.....	343/713
5,406,295	4/1995	Baranski et al.	.....	343/713
5,523,768	6/1996	Hemmie et al.	.....	343/840

### FOREIGN PATENT DOCUMENTS

878479	6/1993	Japan	.
878480	6/1993	Japan	.

Primary Examiner—Jeffrey Asch  
Attorney, Agent, or Firm—Irving M. Fishman

[57] CLAIM

The ornamental design for the antenna for an automobile, as shown and described.

### DESCRIPTION

FIG. 1 is a front view in elevation of the antenna for an automobile showing our new design; FIG. 2 is a rear view in elevation of the antenna for an automobile of FIG. 1; FIG. 3 is a right side view in elevation of the antenna for an automobile of FIG. 1; FIG. 4 is a top plan view of the antenna for an automobile of FIG. 1; and, FIG. 5 is a bottom plan view of the antenna for an automobile of FIG. 1. The left side view of the is a mirror image of the right side shown in FIG. 3.

1 Claim, 1 Drawing Sheet

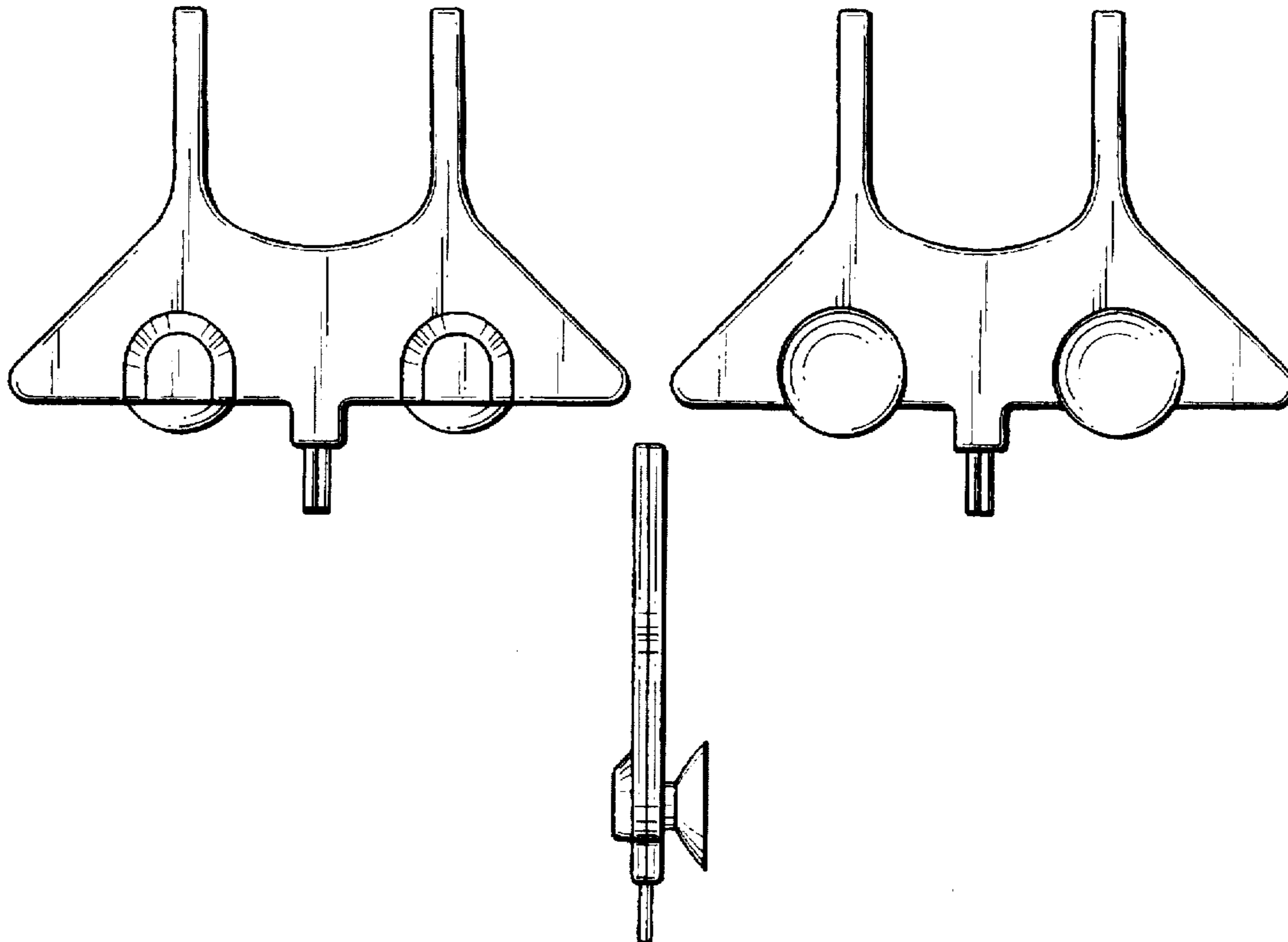

FIG. 1

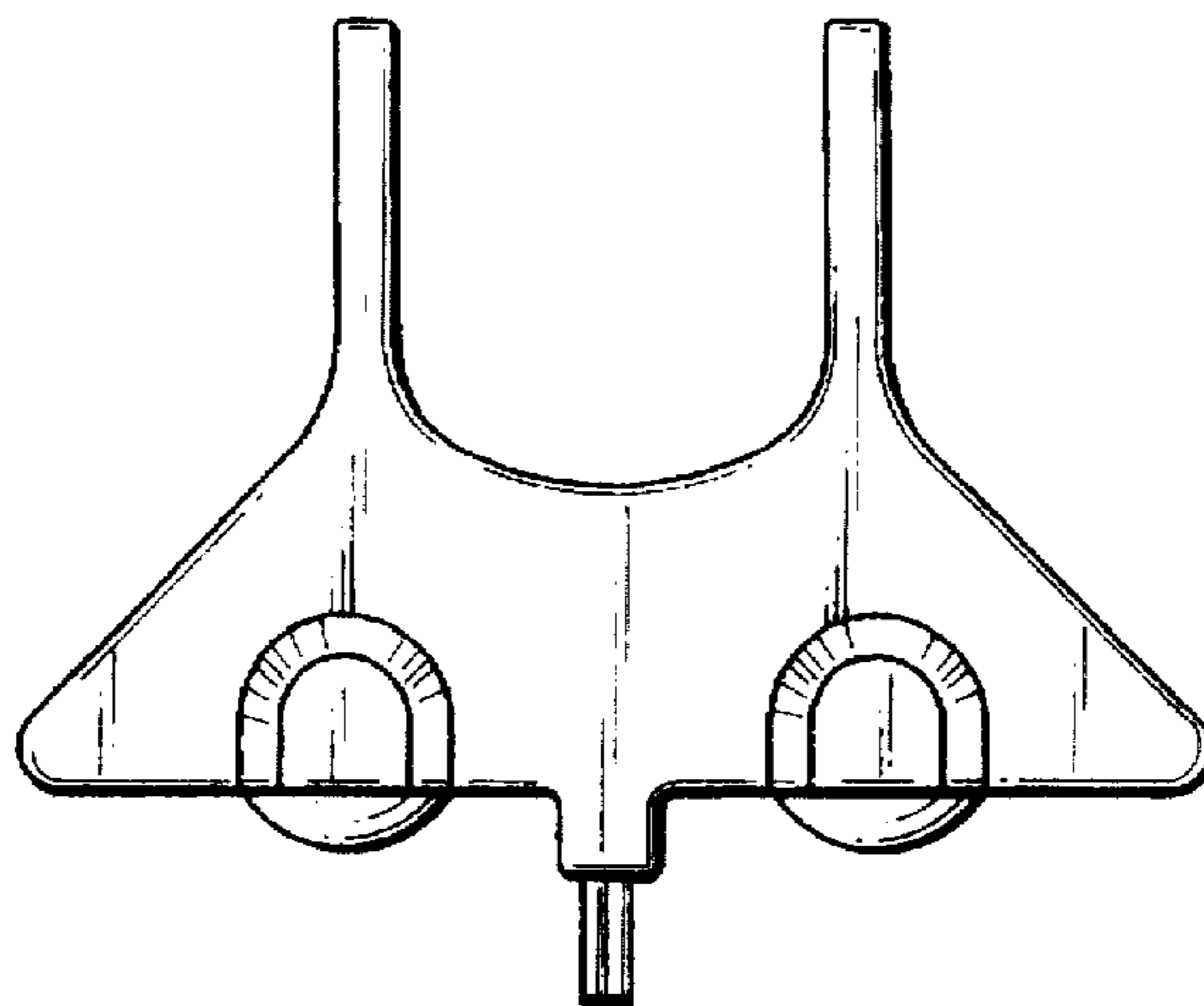

FIG. 2

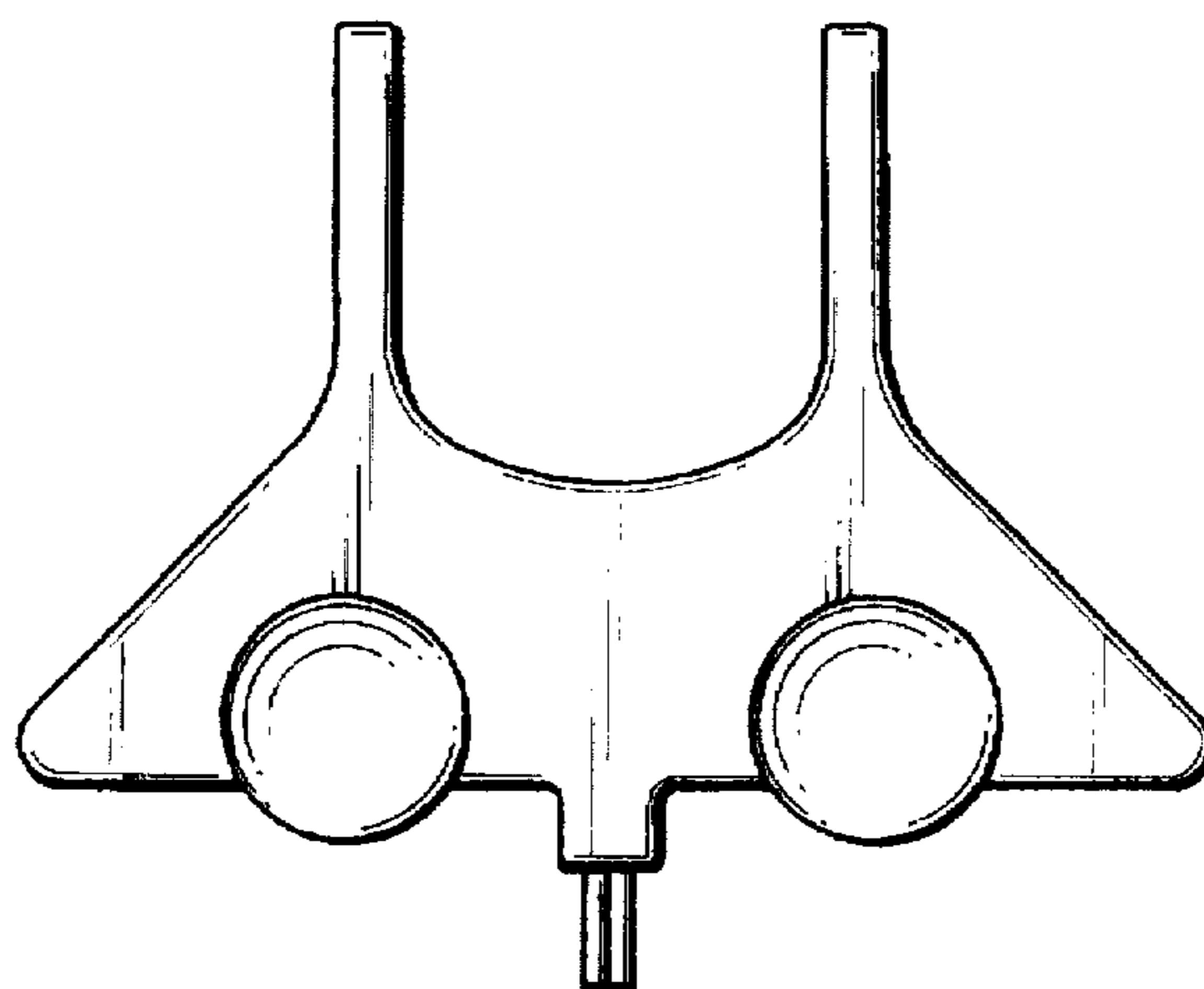

FIG. 3

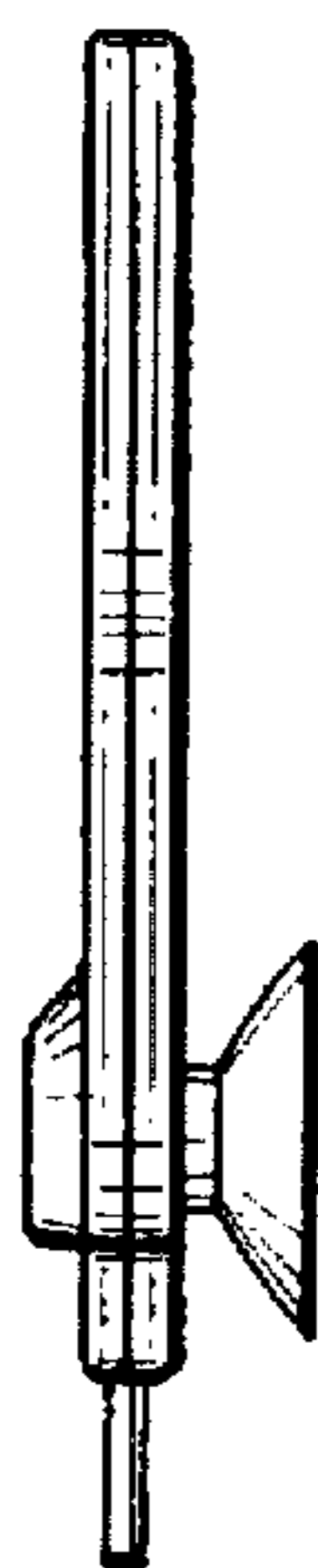

FIG. 4

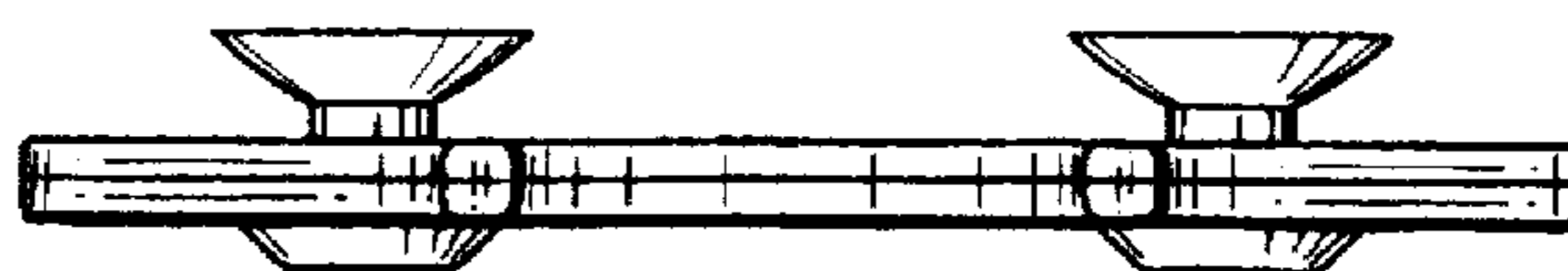

FIG. 5

