



US00D388043S

United States Patent [19]

Elwell et al.

[11] Patent Number: Des. 388,043

[45] Date of Patent: **Dec. 23, 1997

[54] **DECORATIVE TOP EDGE COVER FOR PICKUP TRUCK SIDE WALLS**

[75] Inventors: **Dennis L. Elwell**, Ankeny; **Robert L. Sills**, Story City, both of Iowa

[73] Assignee: **Putco, Inc.**, Story City, Iowa

[**] Term: **14 Years**

[21] Appl. No.: **53,538**

[22] Filed: **Apr. 24, 1996**

[51] LOC (6) Cl. **12-16**

[52] U.S. Cl. **D12/190**

[58] Field of Search D12/98, 167, 181, D12/190, 400, 401; 280/770; 293/128; 296/32; 428/31

[56] **References Cited**

U.S. PATENT DOCUMENTS

D. 264,833 6/1982 Trobmy et al. D12/190

(List continued on next page.)

Primary Examiner—James Gandy

Assistant Examiner—R. Spear

Attorney, Agent, or Firm—Zarley, McKee, Thomte, Voorhees, & Sease

[57] **CLAIM**

The ornamental design for a decorative top edge cover for pickup truck side walls, as shown and described.

DESCRIPTION

FIG. 1 is a perspective view of the decorative top edge cover for pickup truck side walls of the present invention;

FIG. 2 is a top plan view thereof, shown at a reduced scale for ease of disclosure;

FIG. 3 is a bottom plan view thereof, shown at a reduced scale for ease of disclosure;

FIG. 4 is a rear elevational view thereof, shown at an enlarged scale and broken away in the middle for clarity of illustration;

FIG. 5 is a front elevational view thereof, shown at an enlarged scale and broken away in the middle for clarity of illustration;

FIG. 6 is an end elevational view thereof as viewed from the right of FIG. 1, shown at an enlarged scale for clarity of illustration;

FIG. 7 is an end elevational view as viewed from the left of FIG. 1, shown at an enlarged scale for clarity of illustration;

FIG. 8 is a perspective view of a second embodiment of the design for a decorative top flange cover for pickup truck side walls;

FIG. 9 is a top plan view thereof, shown at a reduced scale for ease of disclosure;

FIG. 10 is a bottom plan view thereof, shown at a reduced scale for ease of disclosure;

FIG. 11 is a rear elevational view thereof, shown at an enlarged scale and broken away in the middle for clarity of illustration;

FIG. 12 is a front elevational view thereof, shown at an enlarged scale broken away in the middle for clarity of illustration;

FIG. 13 is an end elevational view as viewed from the right end thereof, shown at an enlarged scale for clarity of illustration;

FIG. 14 is an end elevational view as viewed from the left end thereof, shown at an enlarged scale for clarity of illustration;

FIG. 15 is a perspective view of a third embodiment of the design for the decorative top edge cover for pickup truck side walls;

FIG. 16 is a top plan view thereof, shown at a reduced scale for ease of disclosure;

FIG. 17 is a bottom plan view thereof, shown at a reduced scale for ease of disclosure;

FIG. 18 is a rear elevational view thereof, shown at an enlarged scale and broken away in the middle for clarity of illustration;

FIG. 19 is a front elevational view thereof, shown at an enlarged scale and broken away in the middle for clarity of illustration;

FIG. 20 is an end elevational view thereof as viewed from the right end of FIG. 15, shown at an enlarged scale for clarity of illustration; and,

FIG. 21 is an end elevational view as viewed from the left end of FIG. 15, shown at an enlarged scale for clarity of illustration.

1 Claim, 10 Drawing Sheets

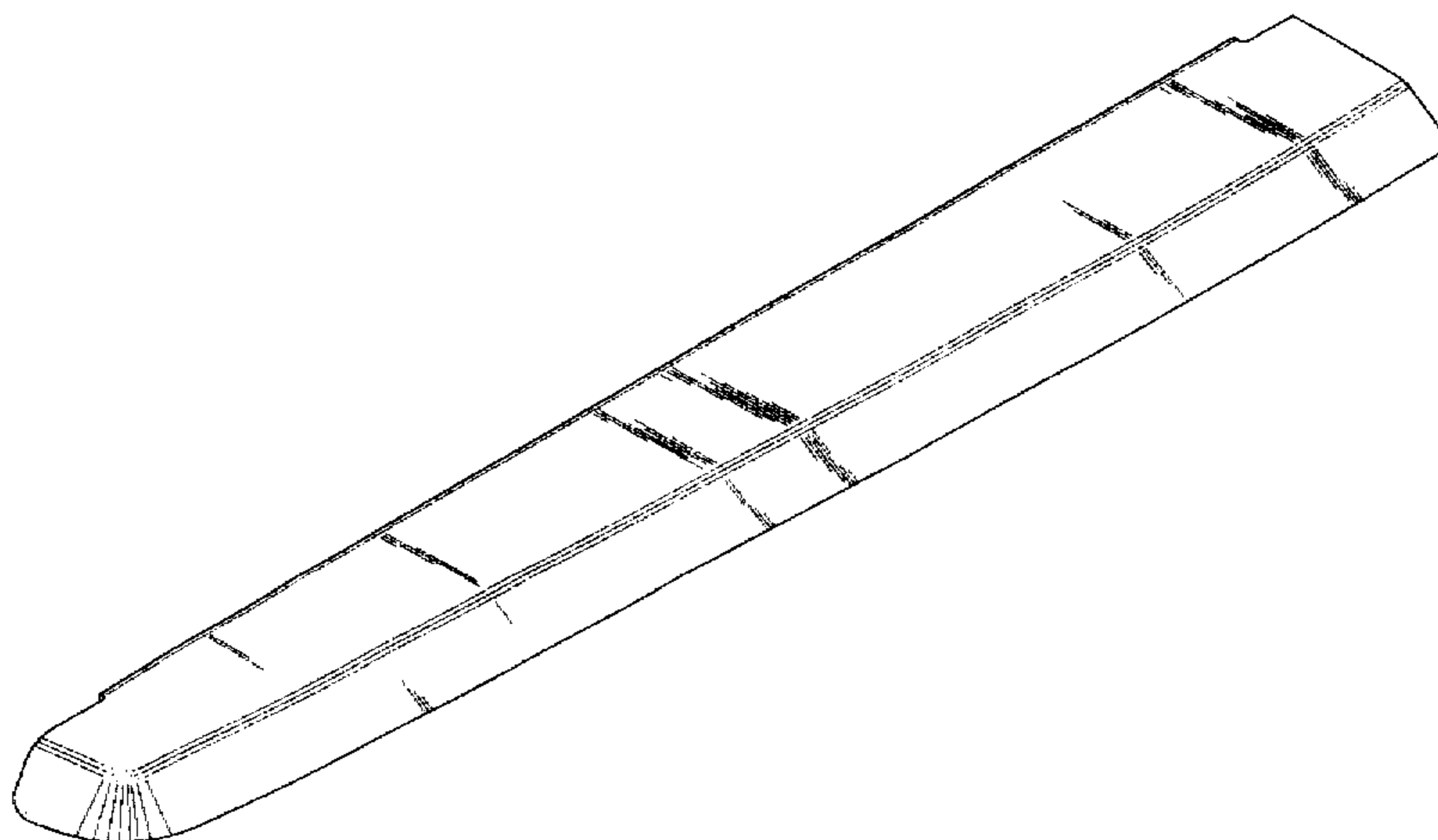

Des. 388,043

Page 2

U.S. PATENT DOCUMENTS			
D. 281,061	10/1985	Tortolani	D12/167
D. 299,017	12/1988	Renn	D12/190
D. 332,072	12/1992	Shirlin et al.	D12/401
D. 355,399	2/1995	Lund	D12/181
4,707,008	11/1987	Falco	293/128
4,872,719	10/1989	Cardwell	296/32
4,909,559	3/1990	Zettle	280/770
5,149,478	9/1992	Malm	428/31

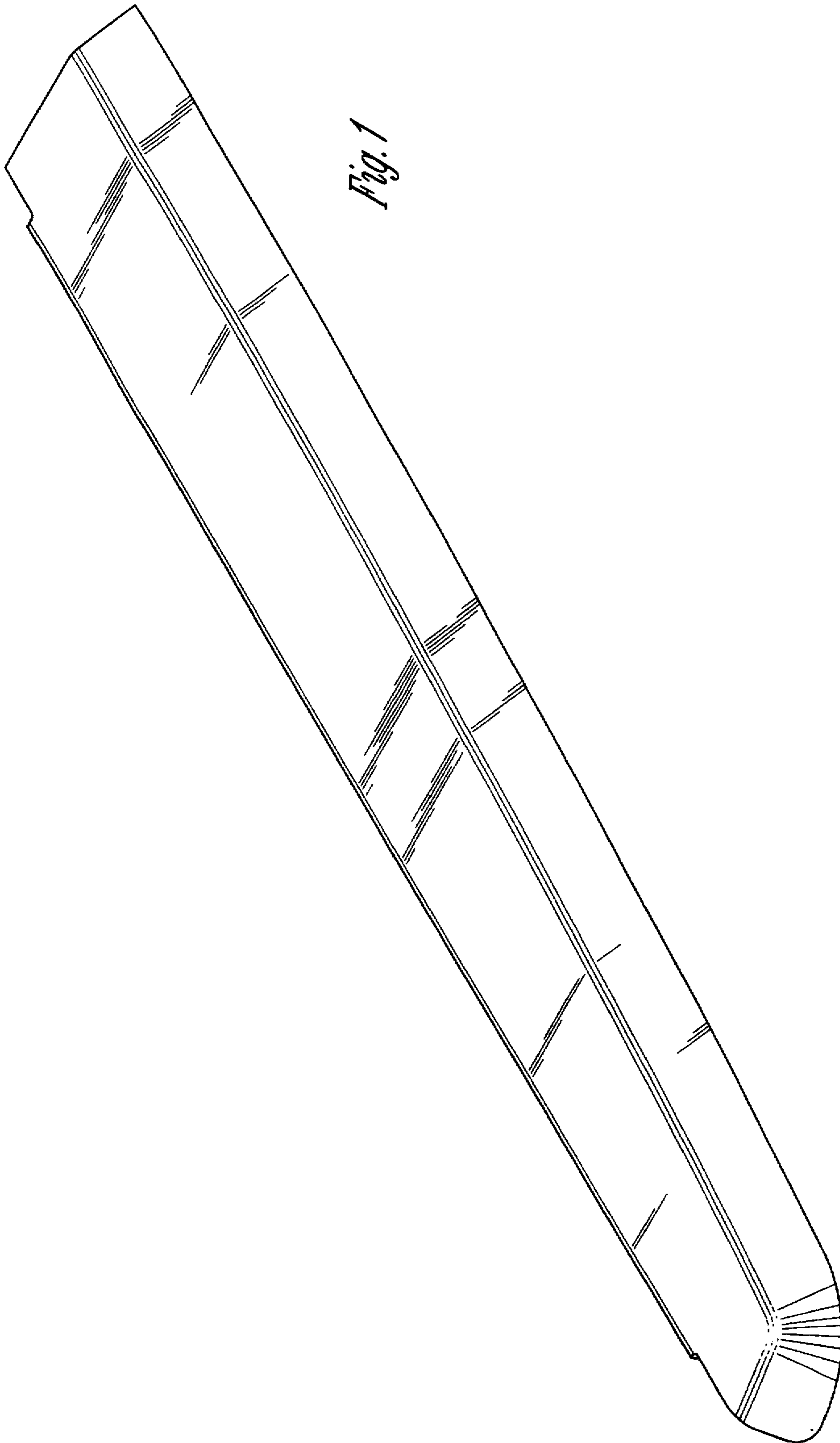

Fig. 1

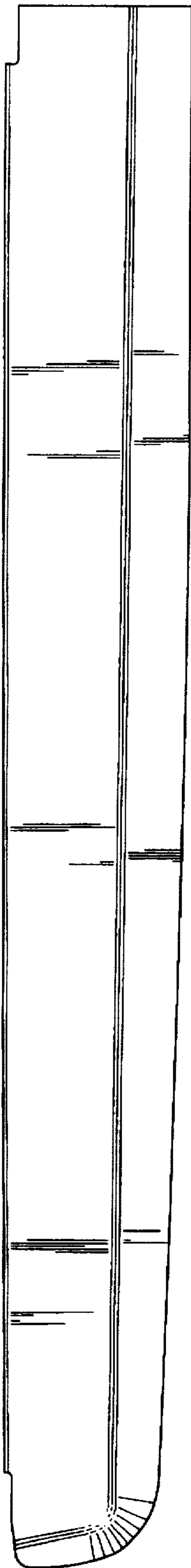

Fig. 2

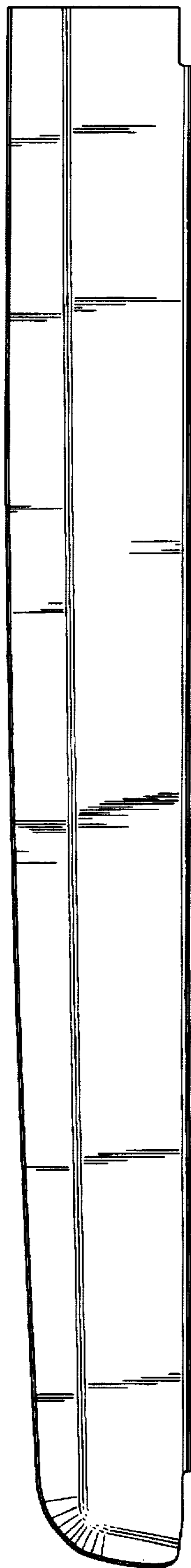
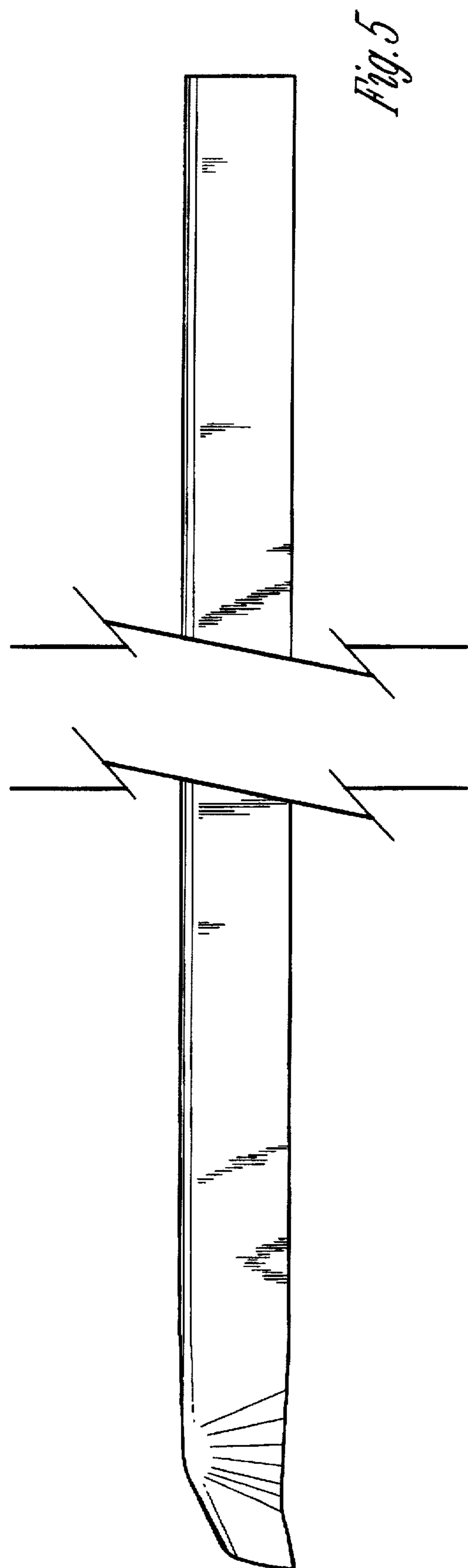
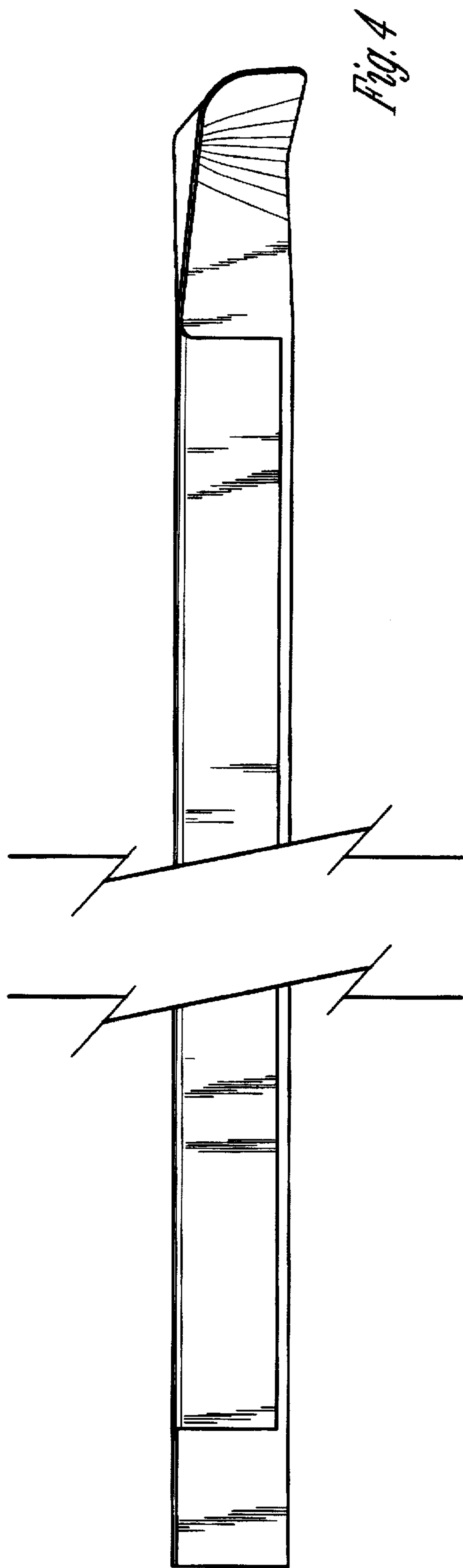

Fig. 3



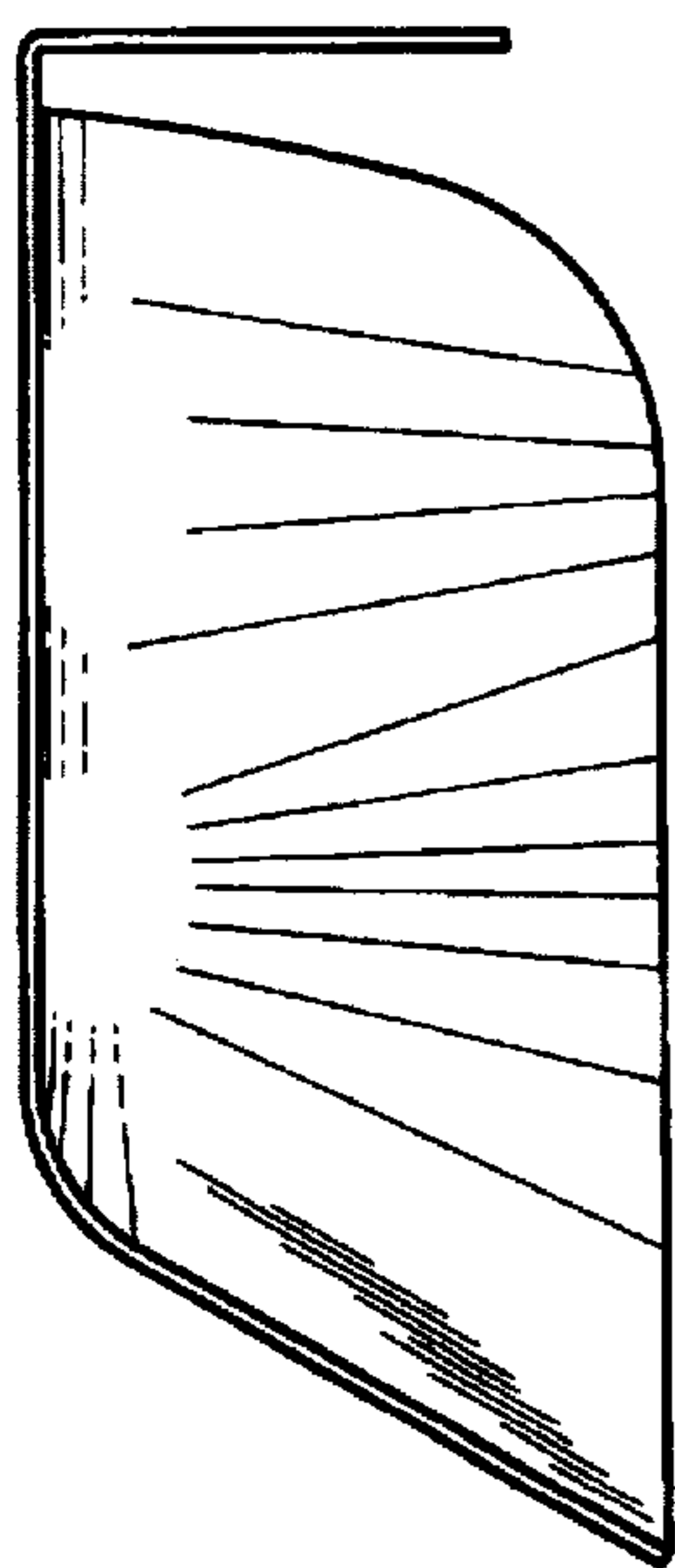

Fig. 6

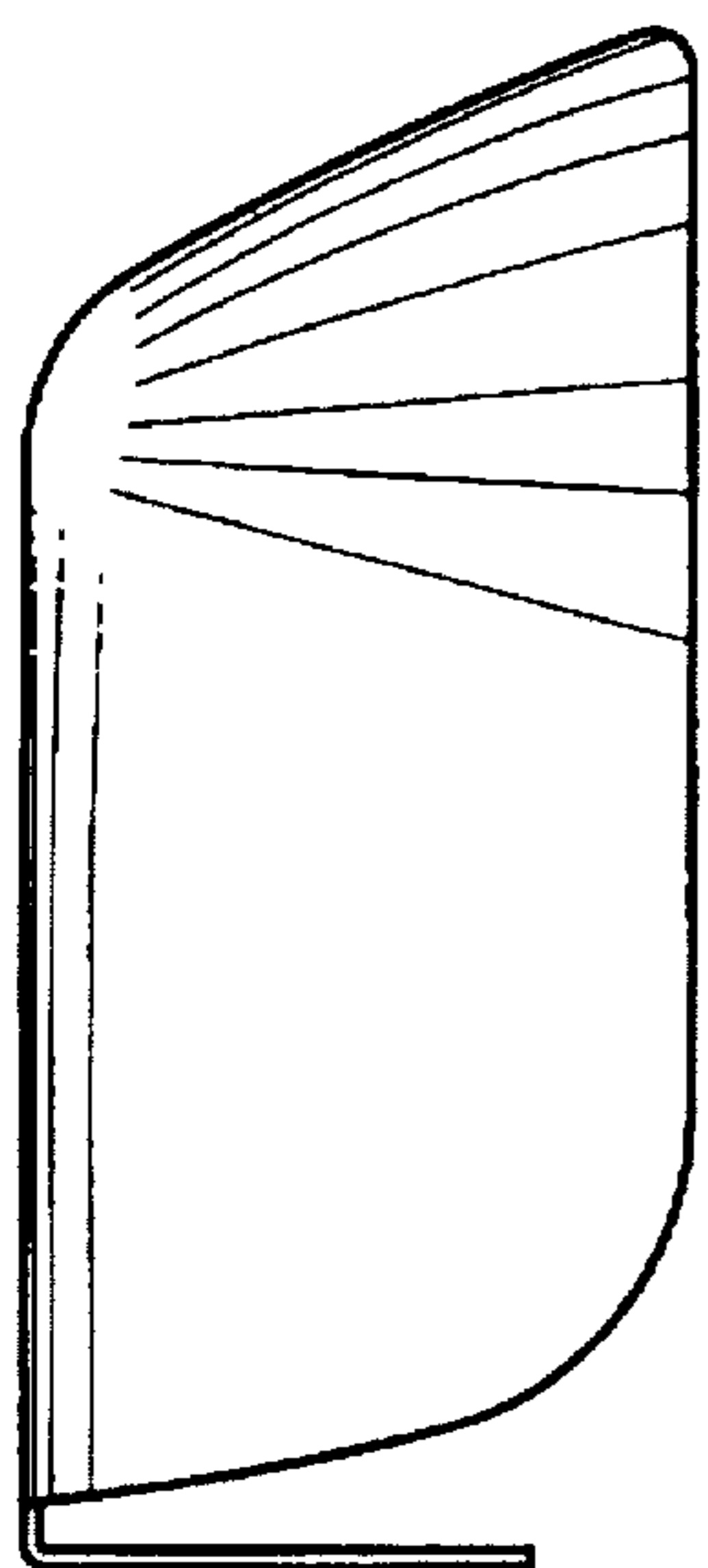

Fig. 7

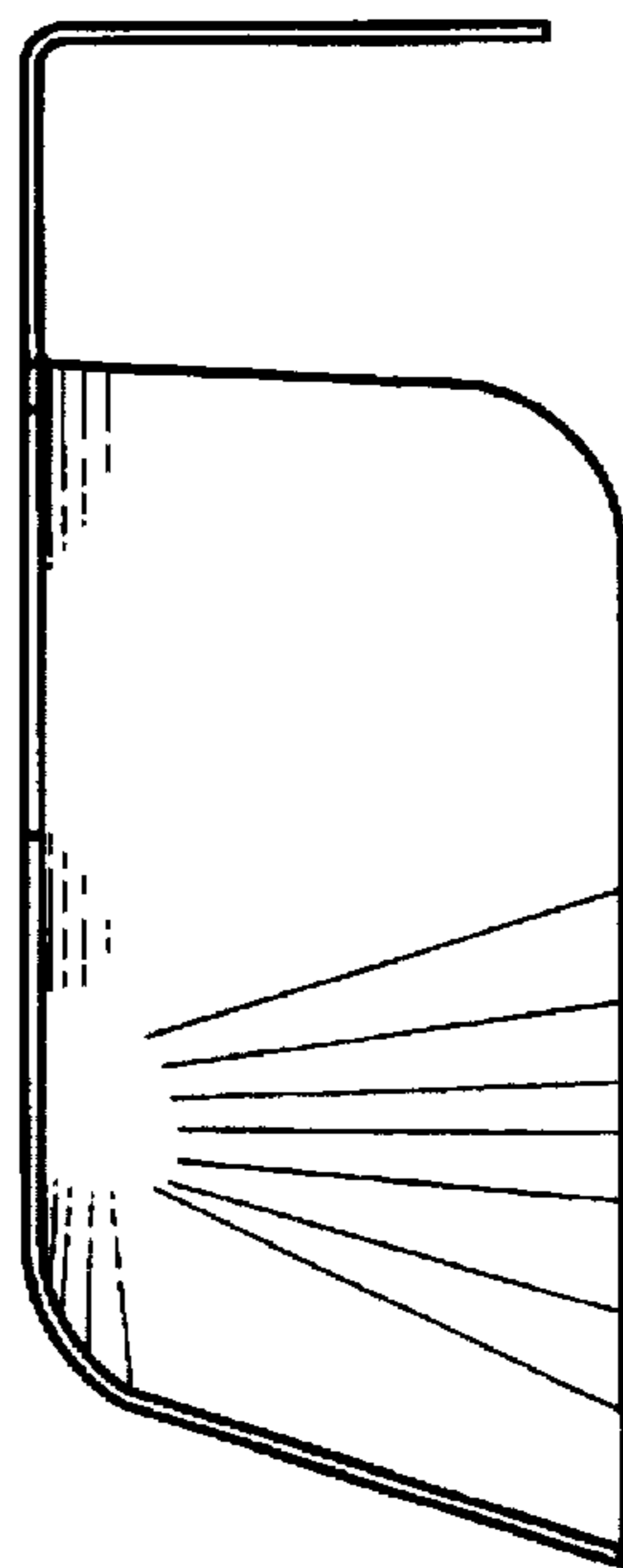

Fig. 13

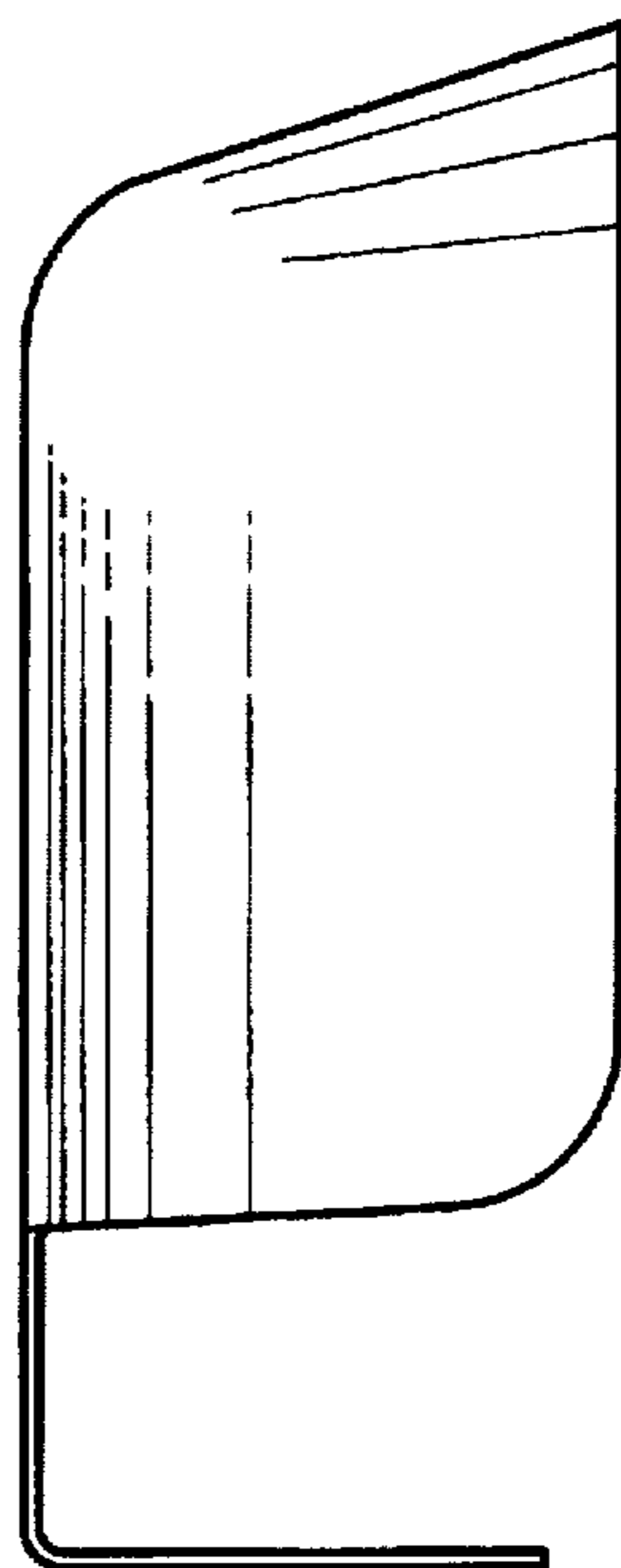

Fig. 14

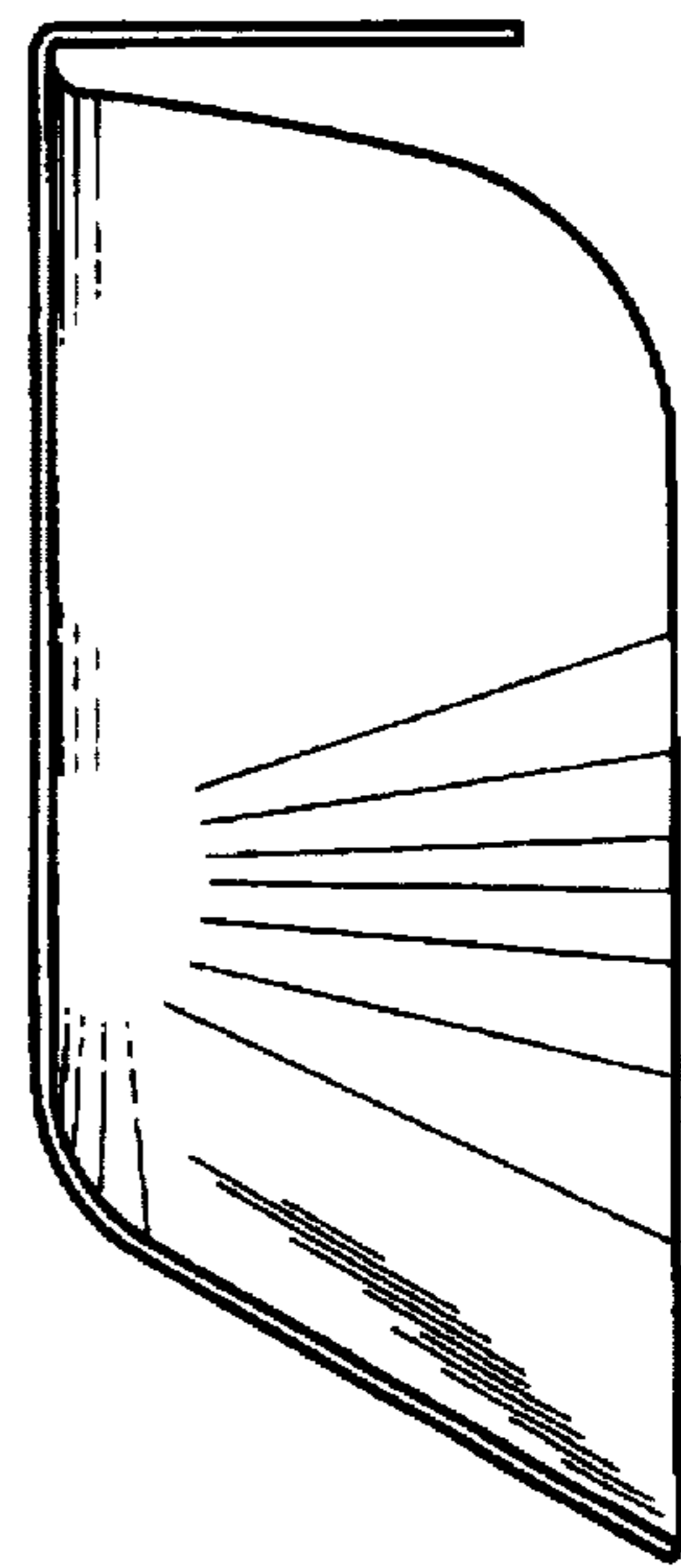

Fig. 20

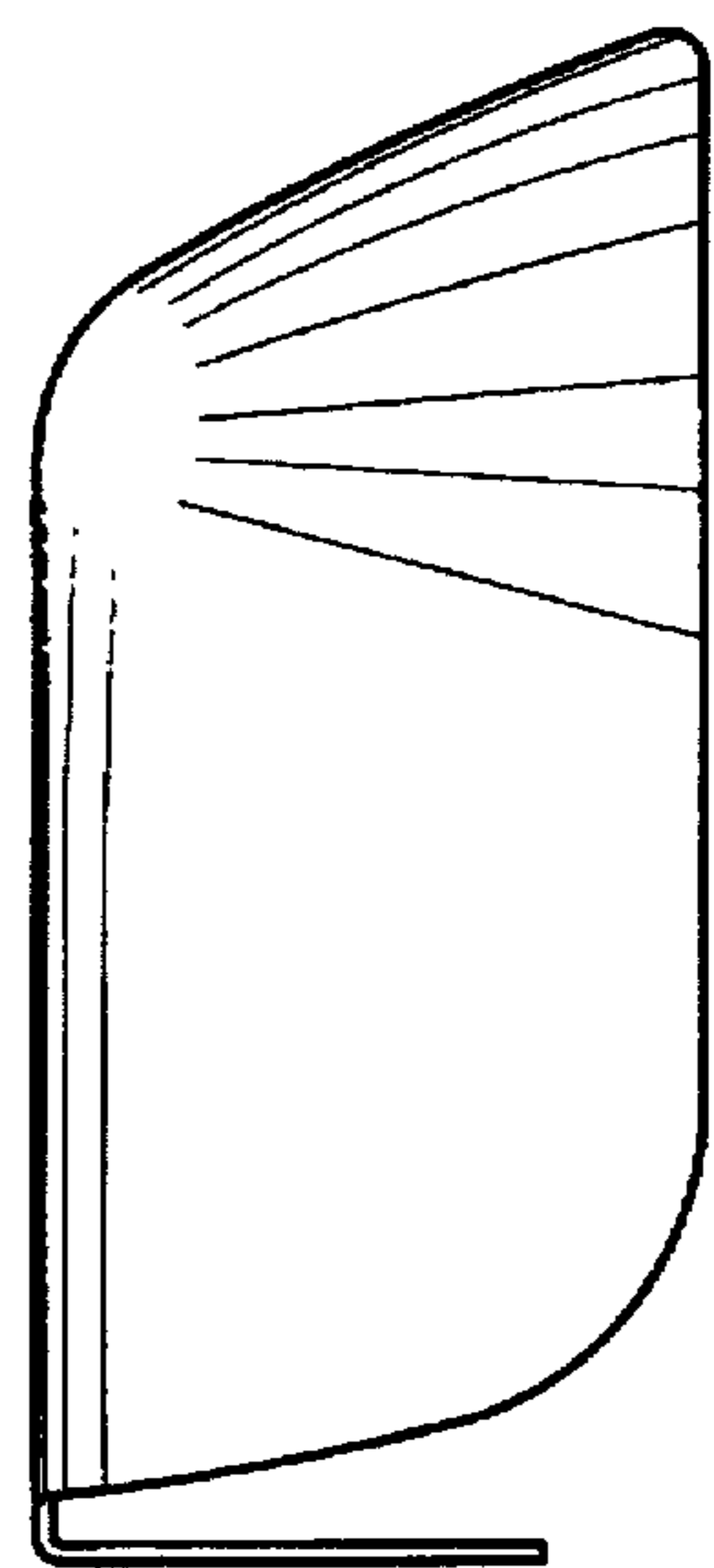

Fig. 21

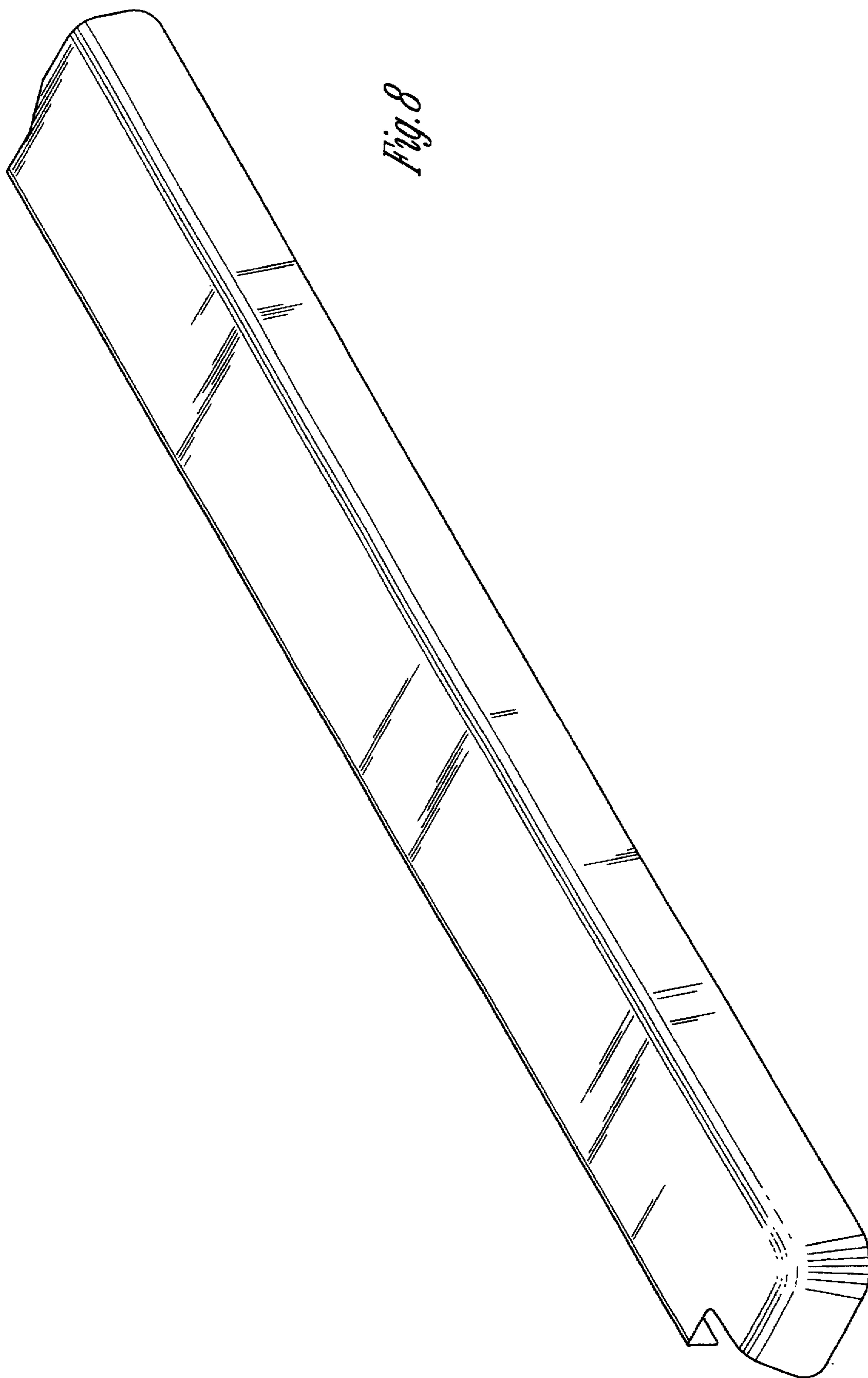

Fig. 8

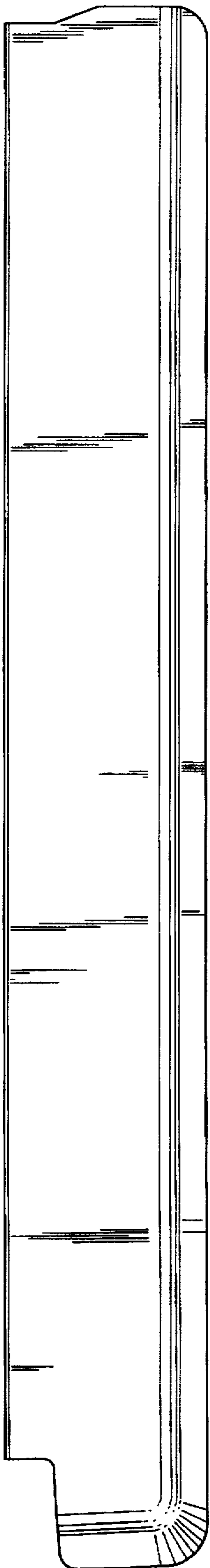

Fig. 9

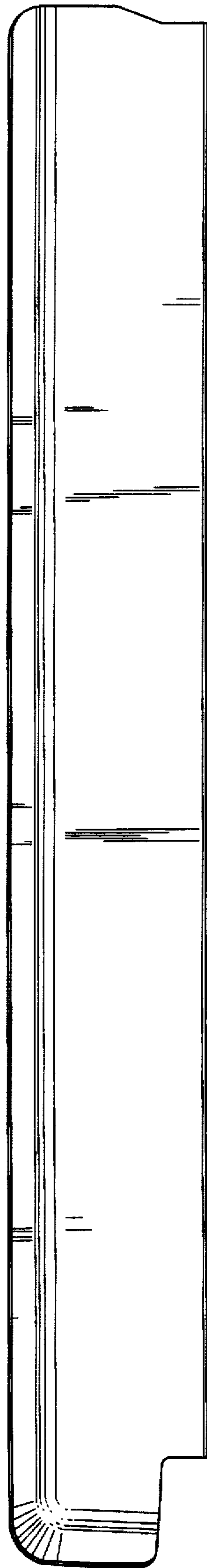
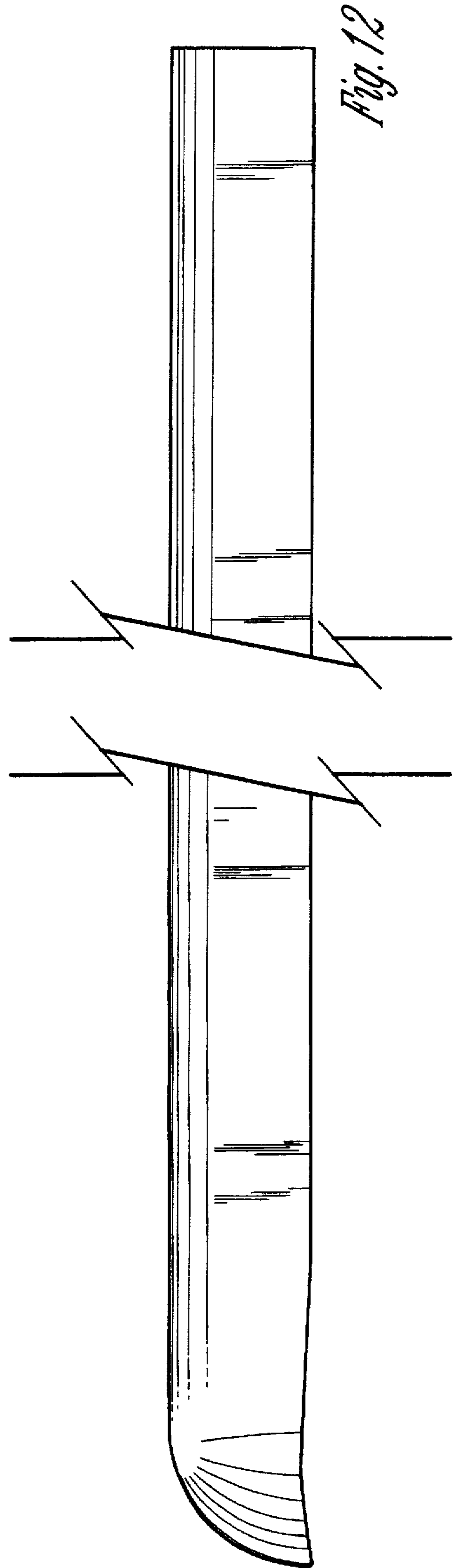
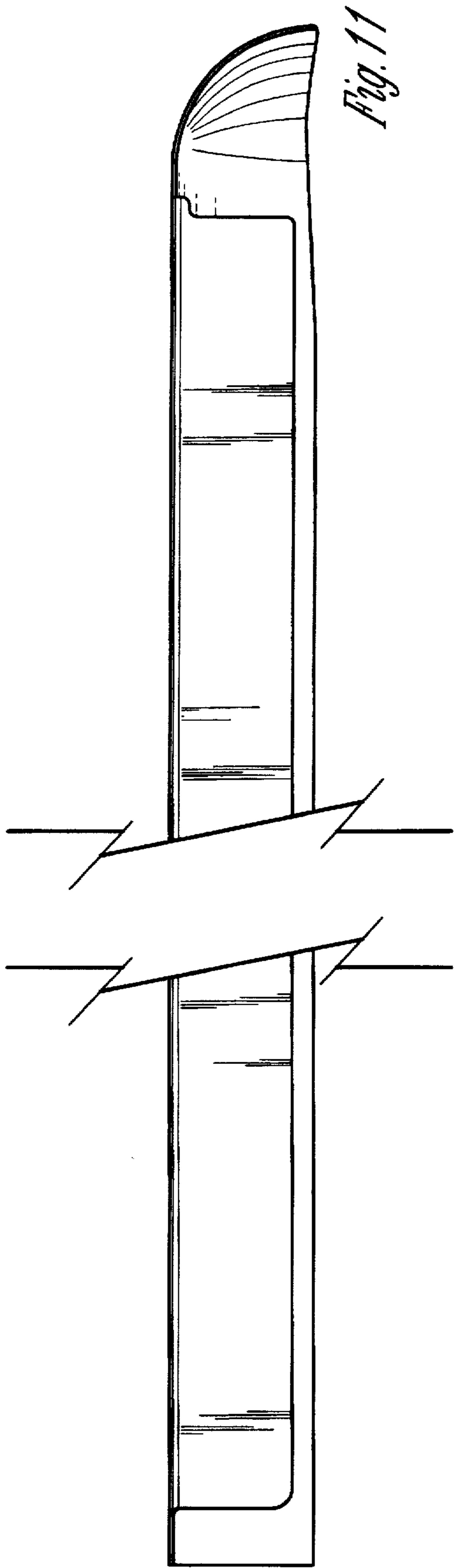

Fig. 10



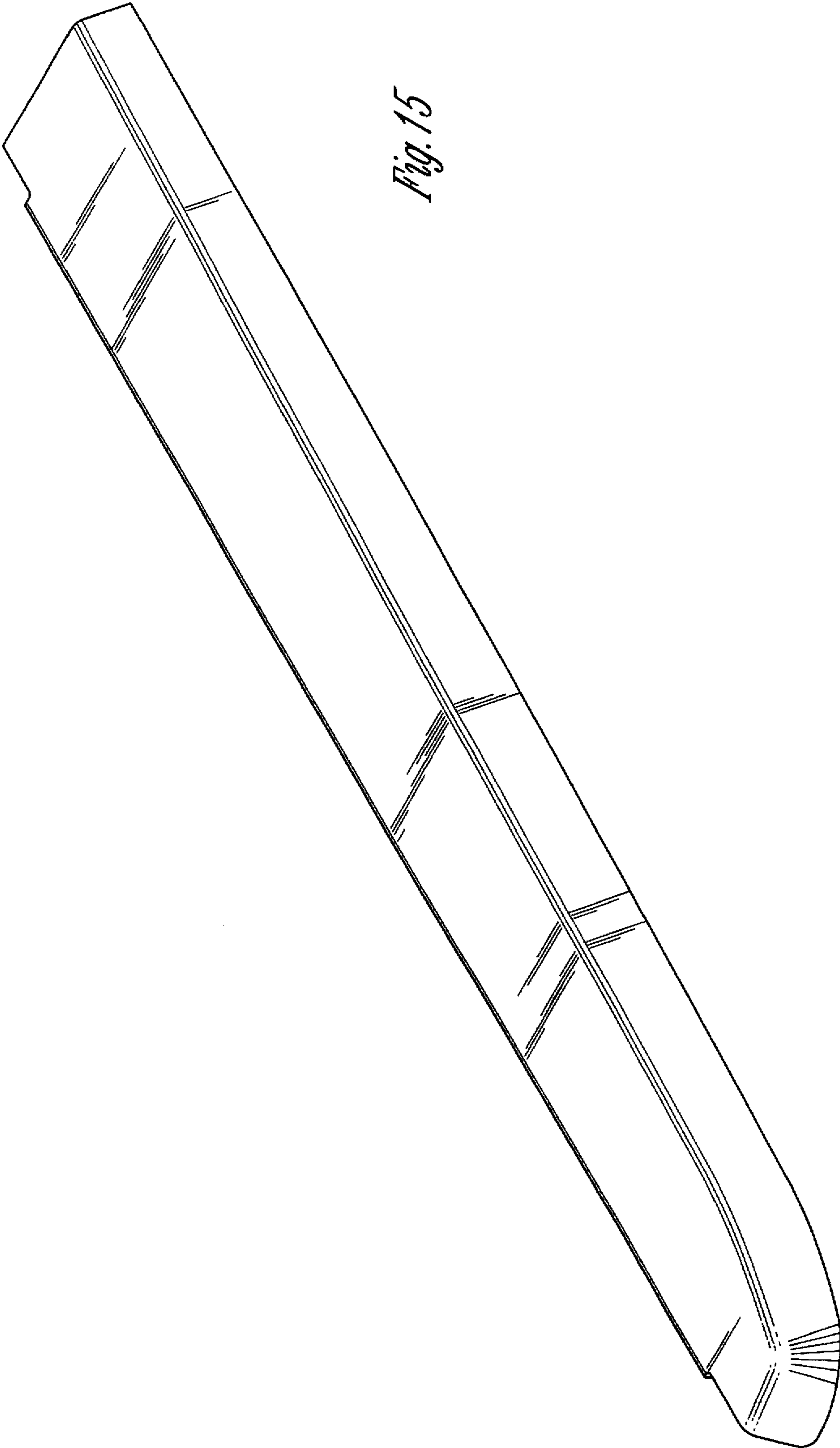

Fig. 15

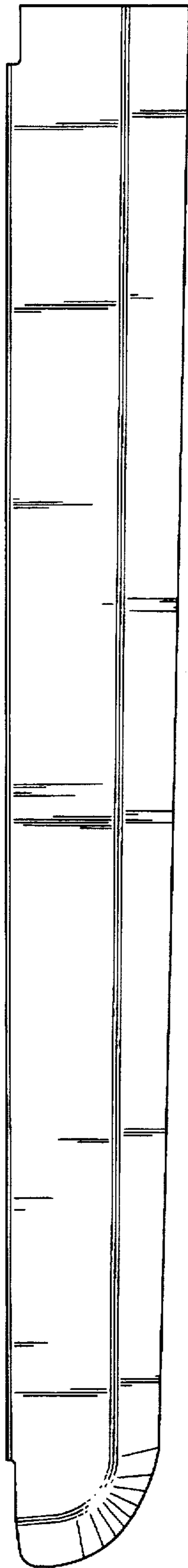

Fig. 16

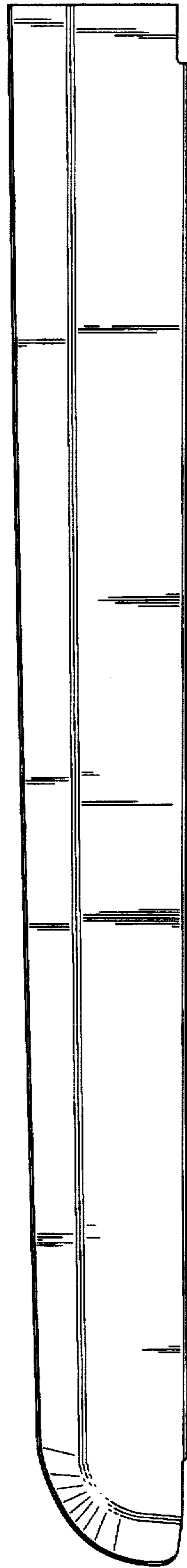

Fig. 17

