



US00D387776S

# United States Patent [19] Chan

[11] Patent Number: Des. 387,776

[45] Date of Patent: \*\*Dec. 16, 1997

## [54] ENGINE BLOCK HEATER EXTENSION

[76] Inventor: **Jamie Chan**, 692 Winger Road,  
Williams Lake, BC, Canada, V2G 3S7

[\*\*] Term: 14 Years

[21] Appl. No.: 61,278

[22] Filed: Oct. 18, 1996

[51] LOC (6) Cl. .... 15-01

[52] U.S. Cl. .... D15/5; D13/140

[58] Field of Search ..... D8/358; D13/140;  
D15/1-5; 191/12.2 R, 12.4; 242/400, 400.1,  
560, 595, 596.7, 598.6; 439/4, 501

### [56] References Cited

#### U.S. PATENT DOCUMENTS

D. 329,637	9/1992	Sutton	.....	D13/140
D. 352,928	11/1994	Ford	.....	D8/358 X
D. 363,461	10/1995	Duckman et al.	.....	D13/140
1,658,694	2/1928	Sturge	.....	191/12.2 R
4,467,979	8/1984	Koehler	.....	439/501 X

## FOREIGN PATENT DOCUMENTS

1419174 10/1969 France ..... 242/400

*Primary Examiner*—Ted Shooman  
*Assistant Examiner*—Nanda Bondade  
*Attorney, Agent, or Firm*—Harold H. Dutton, Jr.

## [57] CLAIM

The ornamental design for an engine block heater extension, as shown.

## DESCRIPTION

FIG. 1 is a perspective view of an engine block heater extension showing my new design; FIG. 2 is a front view thereof; FIG. 3 is a rear view thereof; FIG. 4 is a right view thereof; FIG. 5 is a left view thereof; FIG. 6 is a top view thereof; and, FIG. 7 is a bottom view thereof. FIG. 1 is on an enlarged scale.

1 Claim, 4 Drawing Sheets

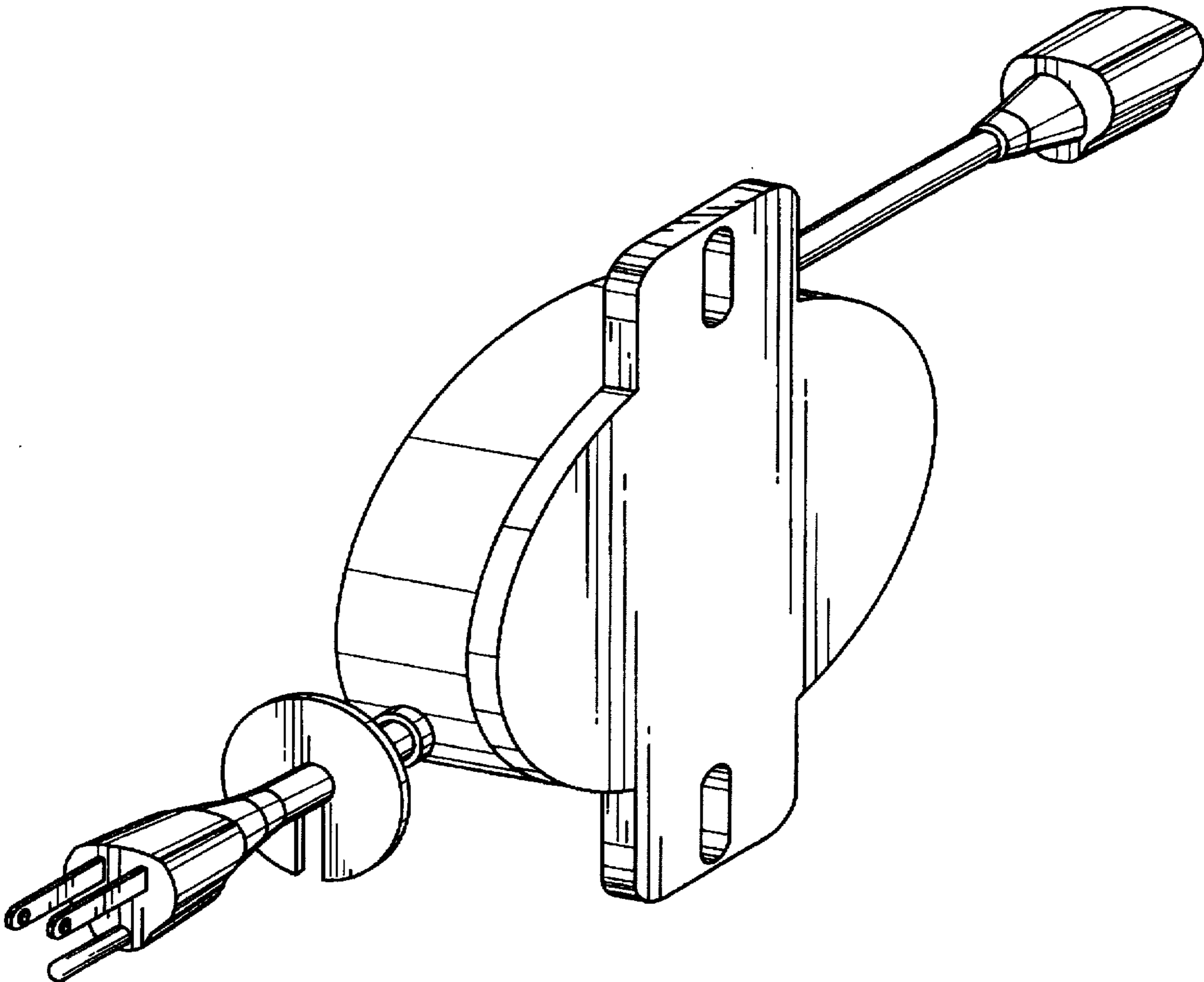

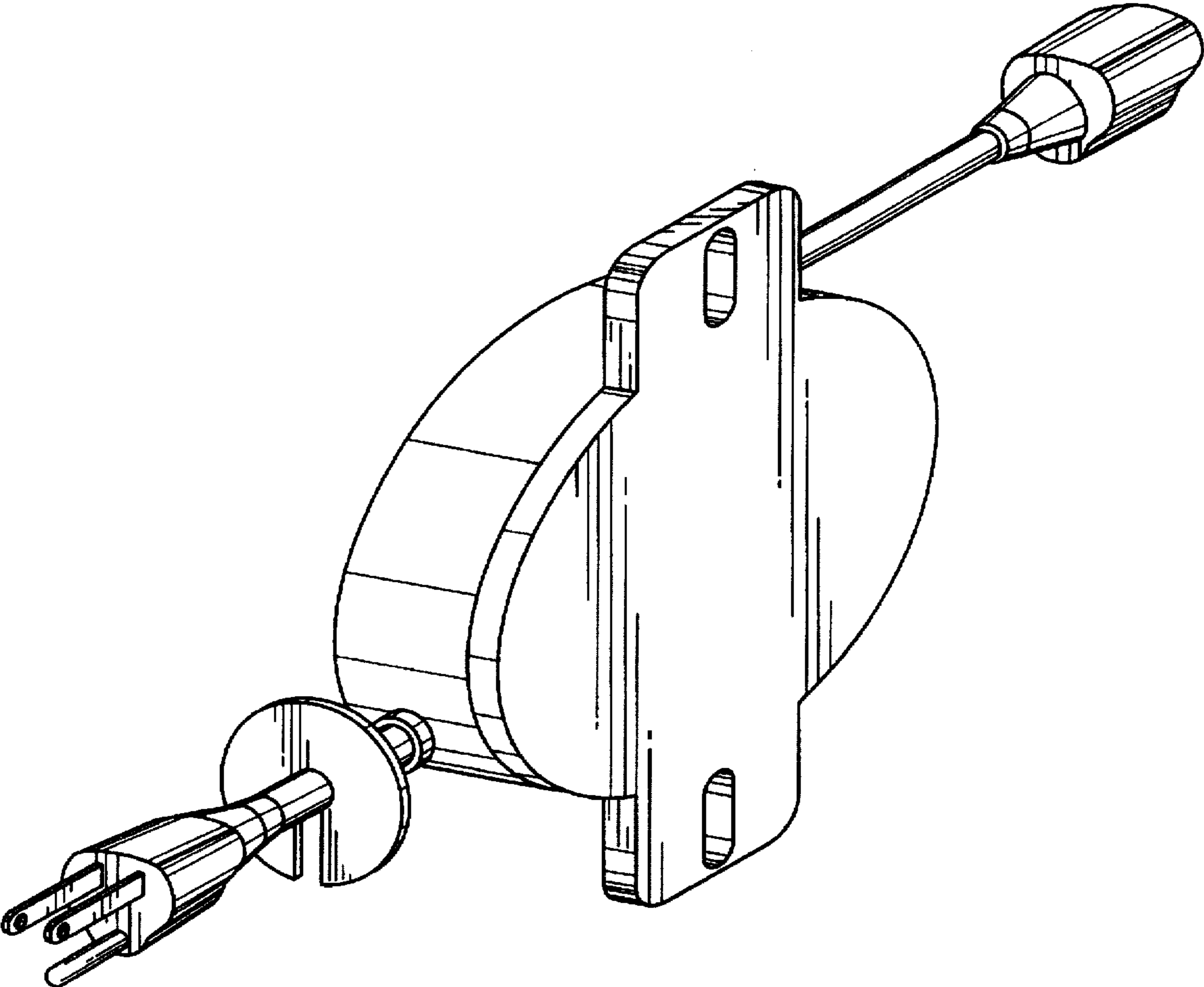

FIG. 1

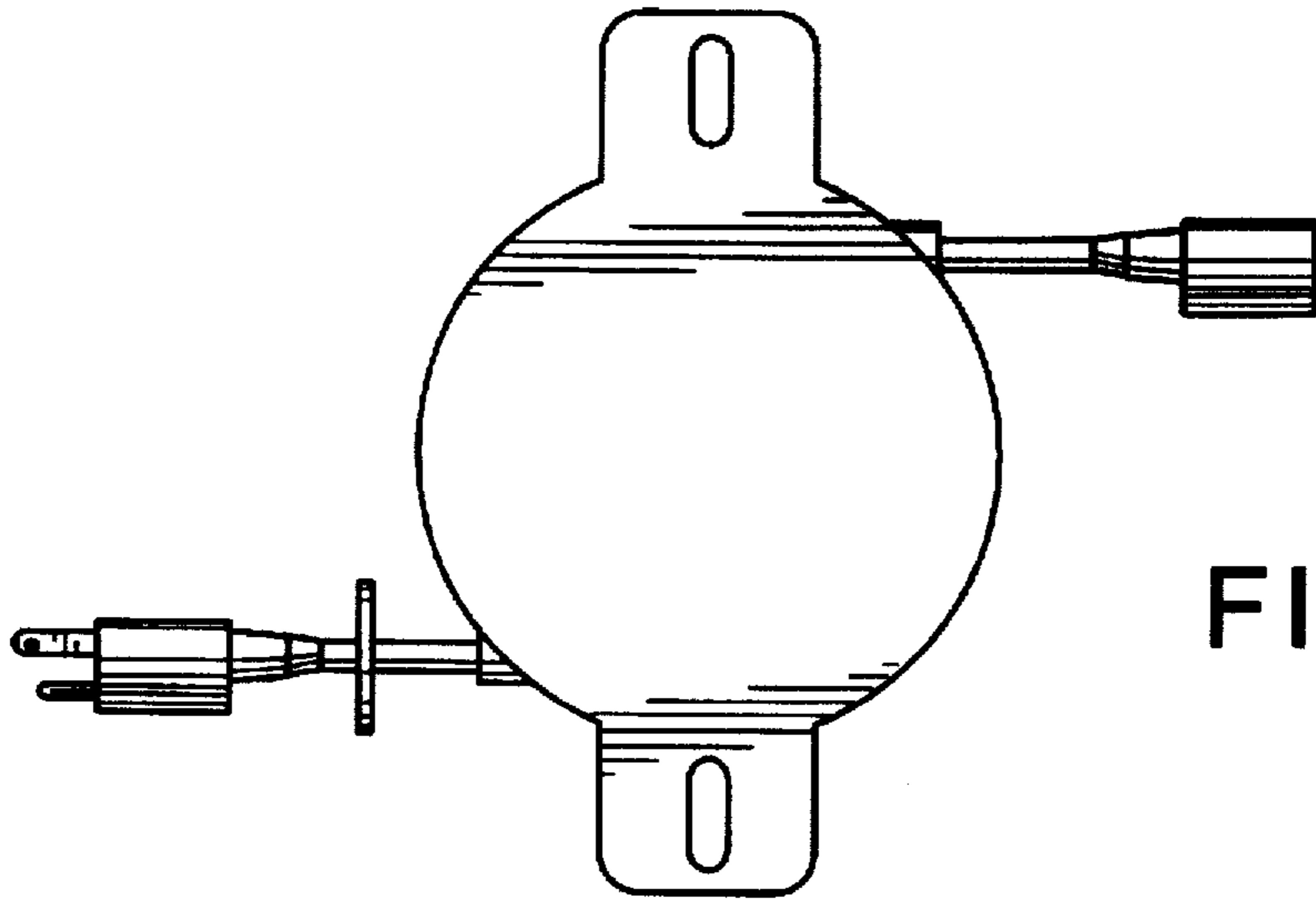

FIG. 2

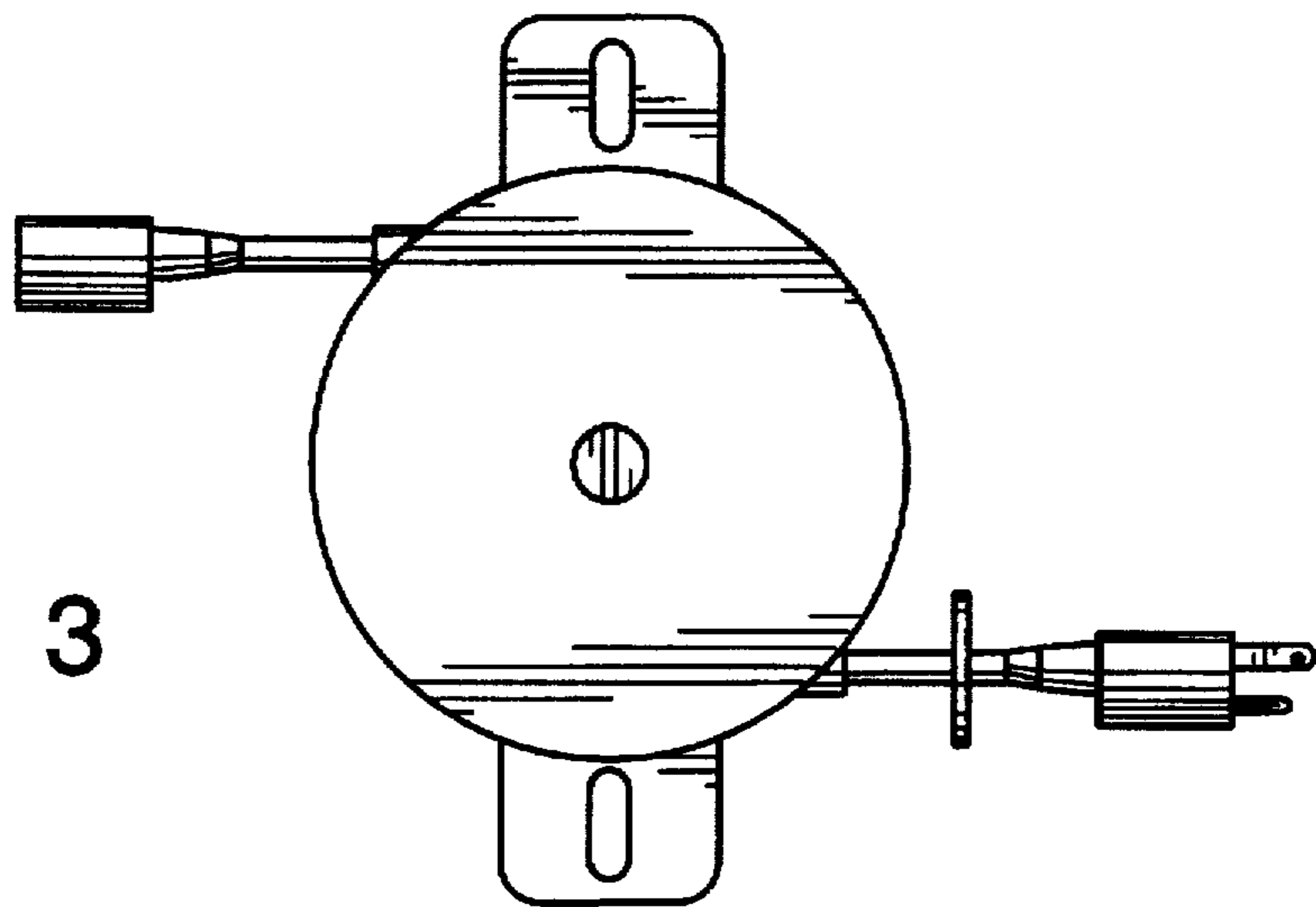

FIG. 3

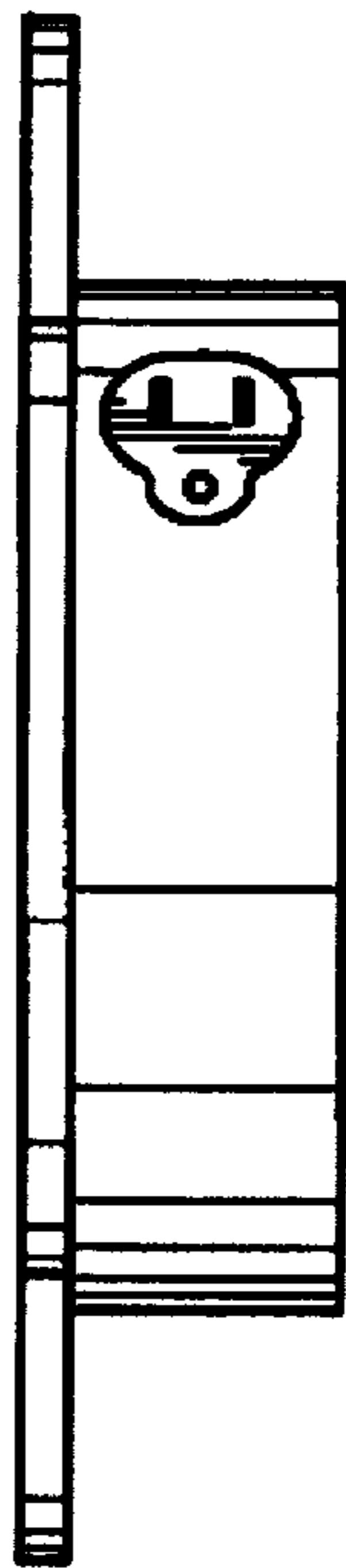
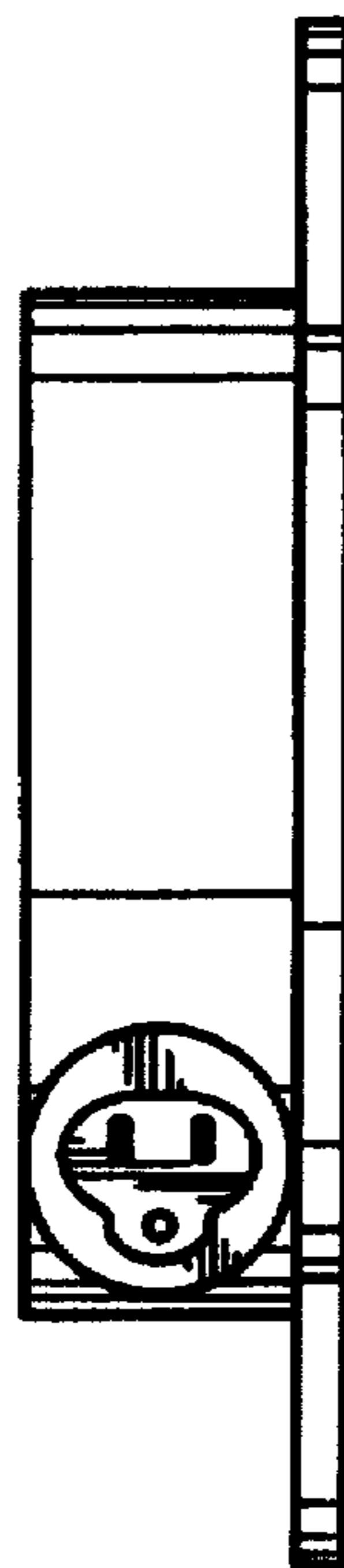

FIG. 4

FIG. 5



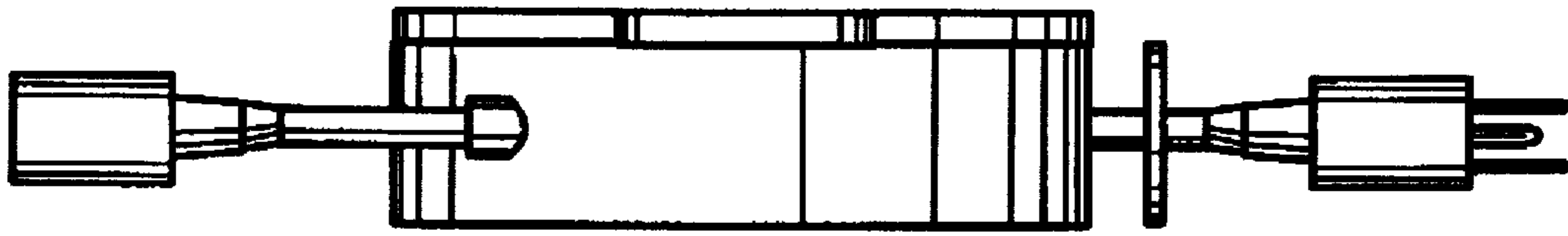

FIG. 6

FIG. 7

