

US00D387775S

United States Patent [19] Iekura

[11] Patent Number: **Des. 387,775**

[45] Date of Patent: ****Dec. 16, 1997**

[54] **OUTBOARD MOTOR**

[75] Inventor: **Shuji Iekura, Kyoto-fu, Japan**

[73] Assignee: **Yamaha Hatsudoki Kabushiki Kaisha, Japan**

[**] Term: **14 Years**

[21] Appl. No.: **57,322**

[22] Filed: **Jul. 23, 1996**

[30] **Foreign Application Priority Data**

Jan. 31, 1996	[JP]	Japan	8-2433
Feb. 7, 1996	[JP]	Japan	8-2922

[51] LOC (6) Cl. **15-01**

[52] U.S. Cl. **D15/4**

[58] Field of Search **D15/4, 149; 123/495; 290/43, 46, 54; 440/3, 4, 6, 52, 53, 75-81, 900**

[56] **References Cited**

U.S. PATENT DOCUMENTS

D. 274,909	7/1984	Ferguson et al.	D15/4
D. 286,157	10/1986	Mikado et al.	D15/4
D. 323,508	1/1992	Hirshberg et al.	D15/4
D. 332,265	1/1993	Osumi	D15/4
D. 359,290	6/1995	Takeuchi	D15/1
4,512,294	4/1985	Mohr	440/900
4,811,717	3/1989	Nakahama	123/495

OTHER PUBLICATIONS

Boating, vol. 63, No. 2, Outboard Feb. 1990.

Primary Examiner—Ted Shooman

Assistant Examiner—Nanda Bondade

Attorney, Agent, or Firm—Ostrolenk, Faber, Gerb & Soffen, LLP

[57] **CLAIM**

The ornamental design for an outboard motor, as shown.

DESCRIPTION

FIG. 1 is a perspective view of an ornamental design for an outboard motor in accordance with a first embodiment of the present invention;

FIG. 2 is a top view of the ornamental design of FIG. 1 ;

FIG. 3 is a bottom view of the ornamental design of FIG. 1;

FIG. 4 is a left side view of the ornamental design of FIG. 1;

FIG. 5 is a front view of the ornamental design of FIG. 1;

FIG. 6 is a rear view of the ornamental design of FIG. 1; and,

FIG. 7 is a right side view of the ornamental design of FIG. 1;

FIG. 8 is a perspective view of an ornamental design for an outboard motor in accordance with a second embodiment of the present invention;

FIG. 9 is a top view of the ornamental design of FIG. 8;

FIG. 10 is a bottom view of the ornamental design of FIG. 8;

FIG. 11 is a left side view of the ornamental design of FIG. 8;

FIG. 12 is a front view of the ornamental design of FIG. 8;

FIG. 13 is a rear view of the ornamental design of FIG. 8 ; and,

FIG. 14 is a right side view of the ornamental design of FIG. 8.

1 Claim, 4 Drawing Sheets

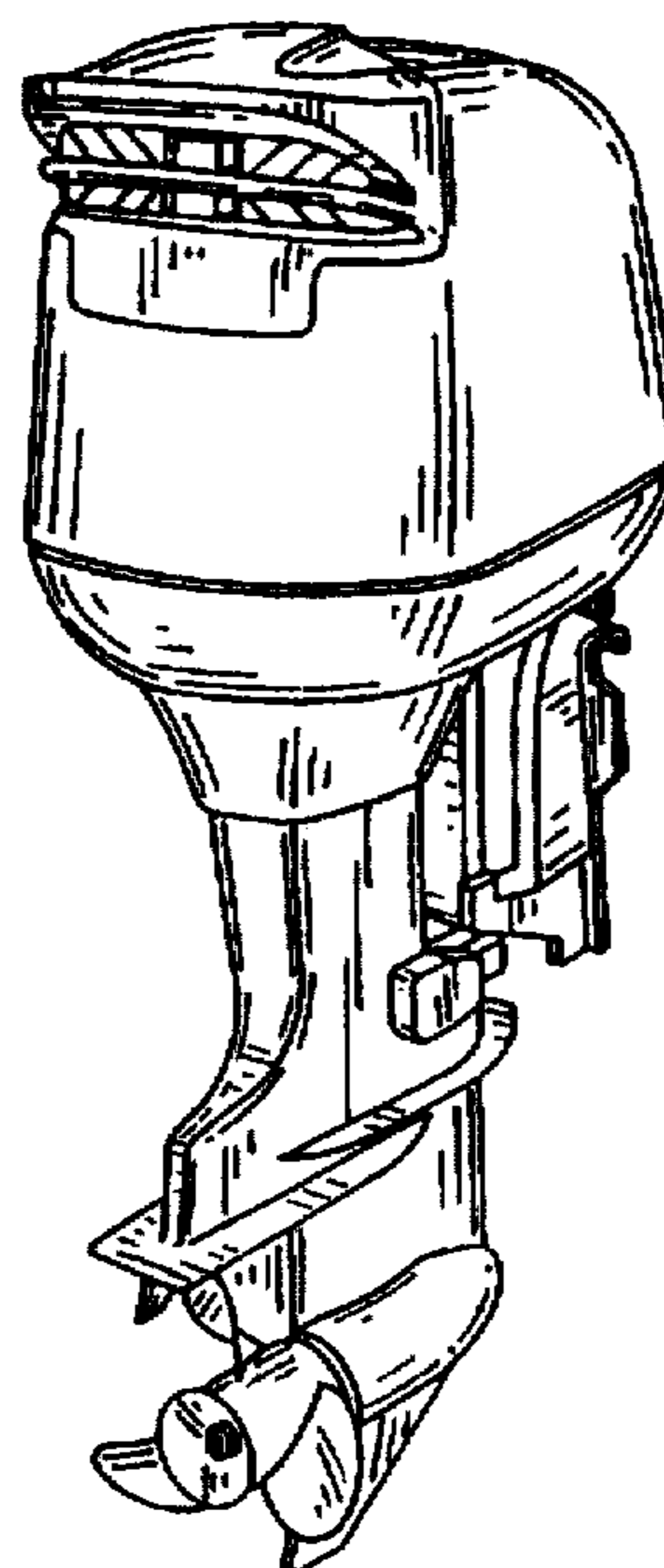
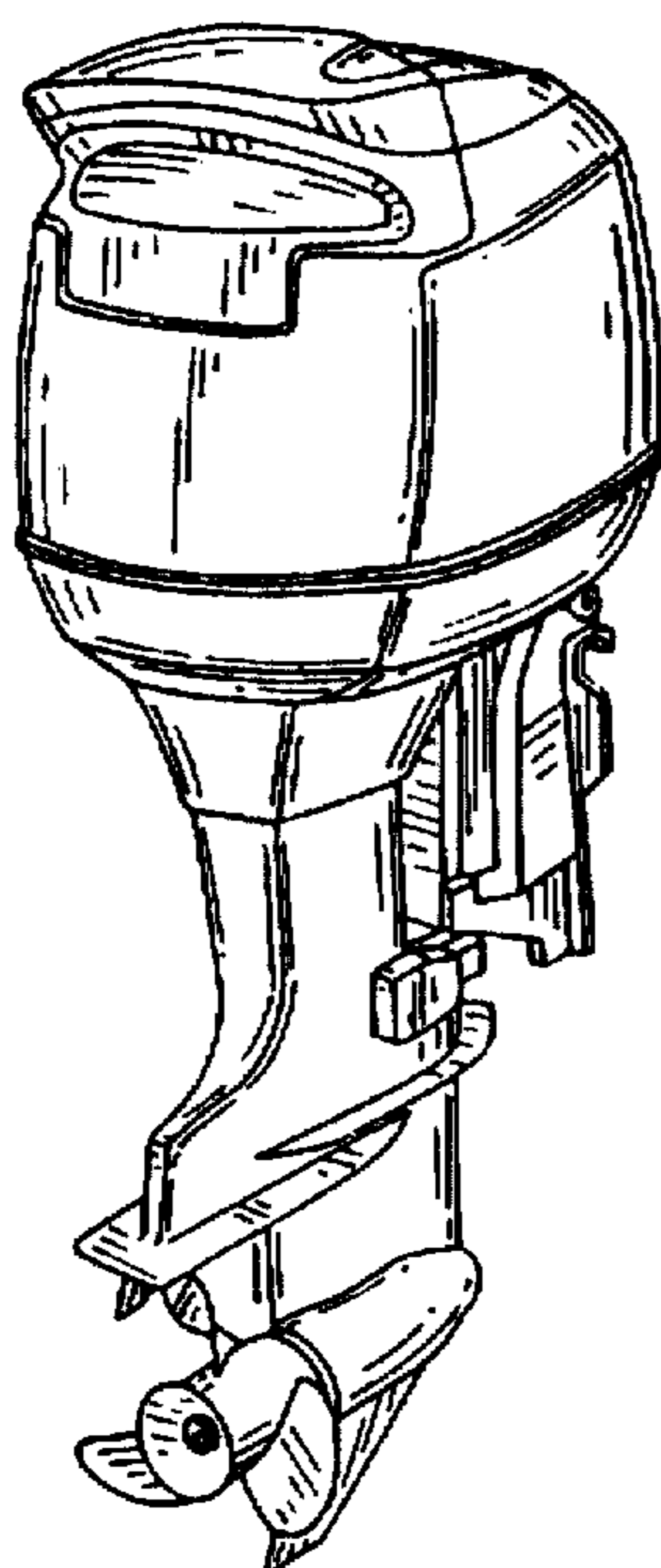

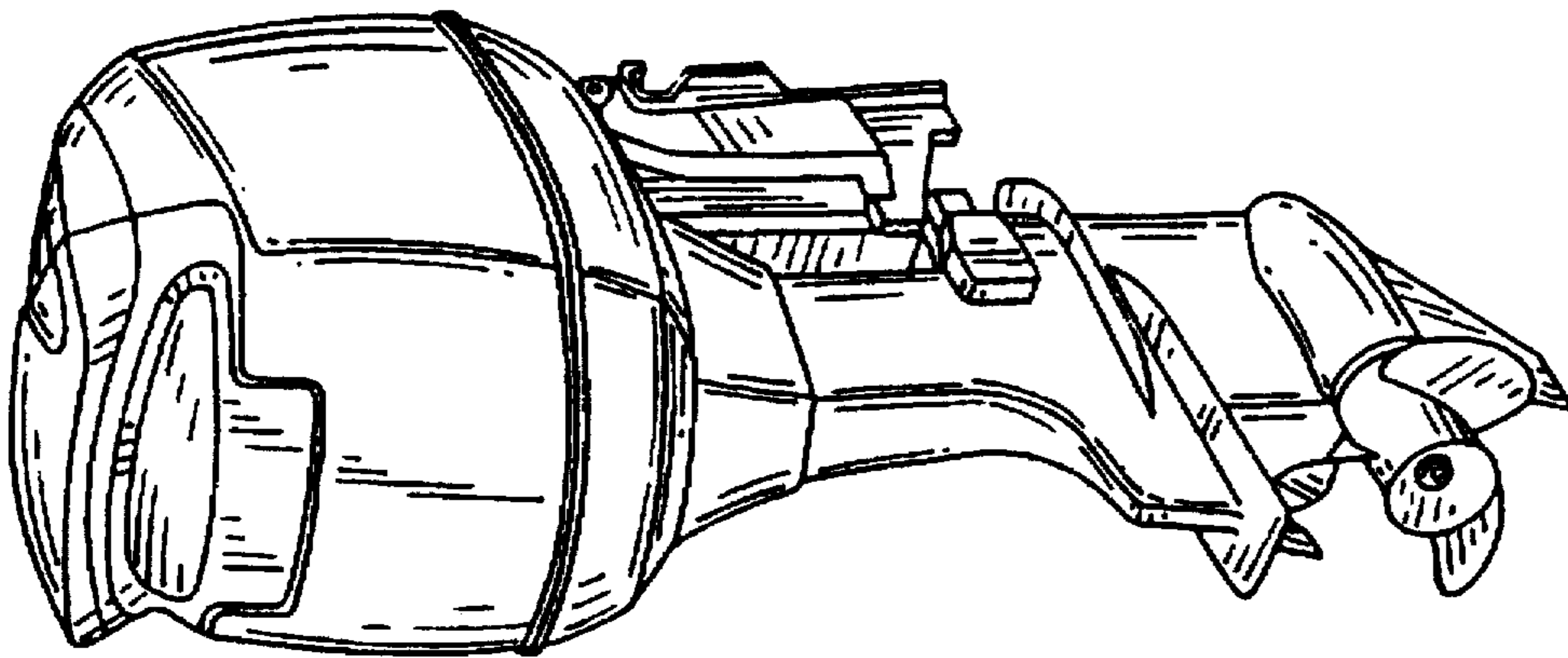

FIG. 1

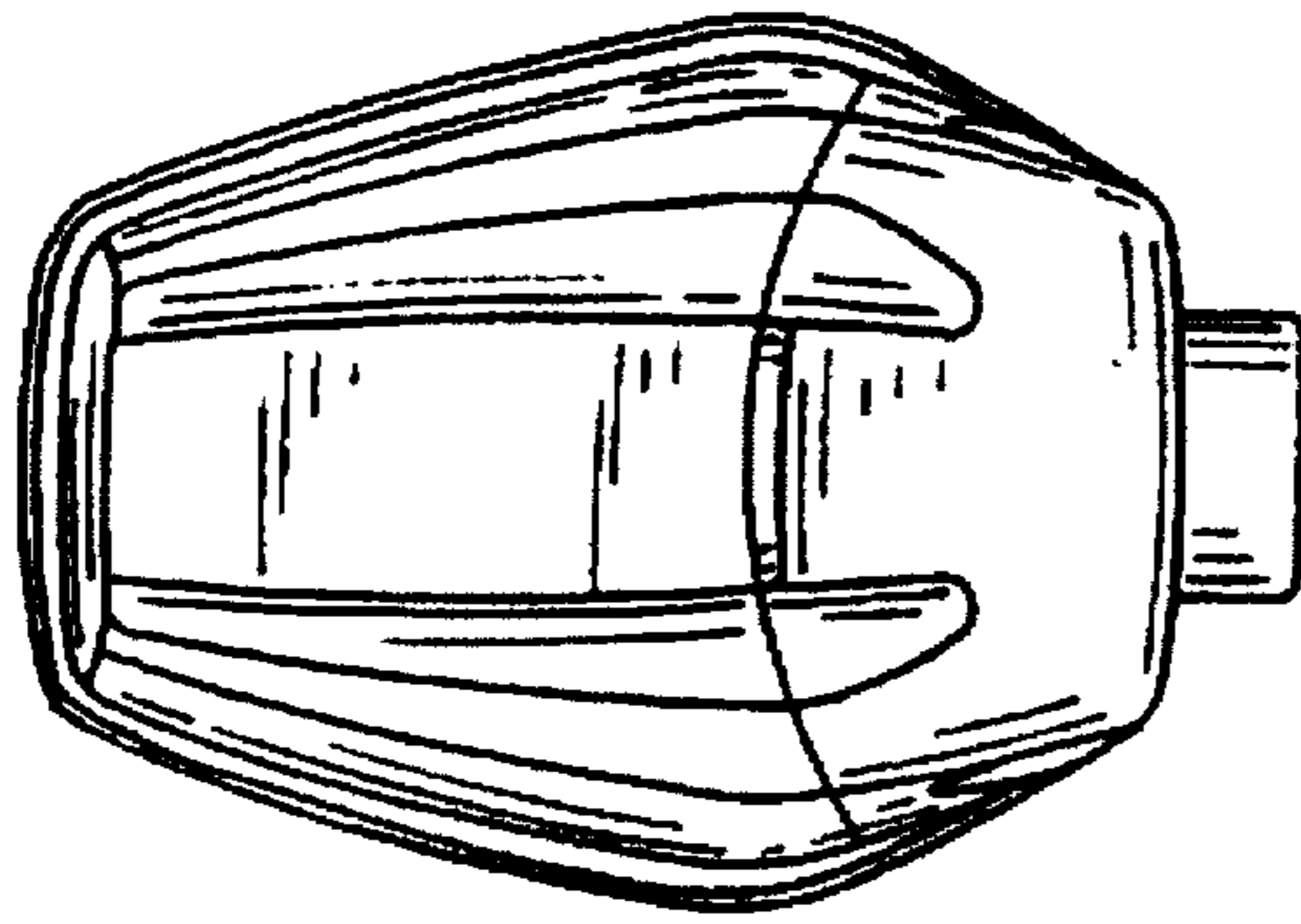

FIG. 2

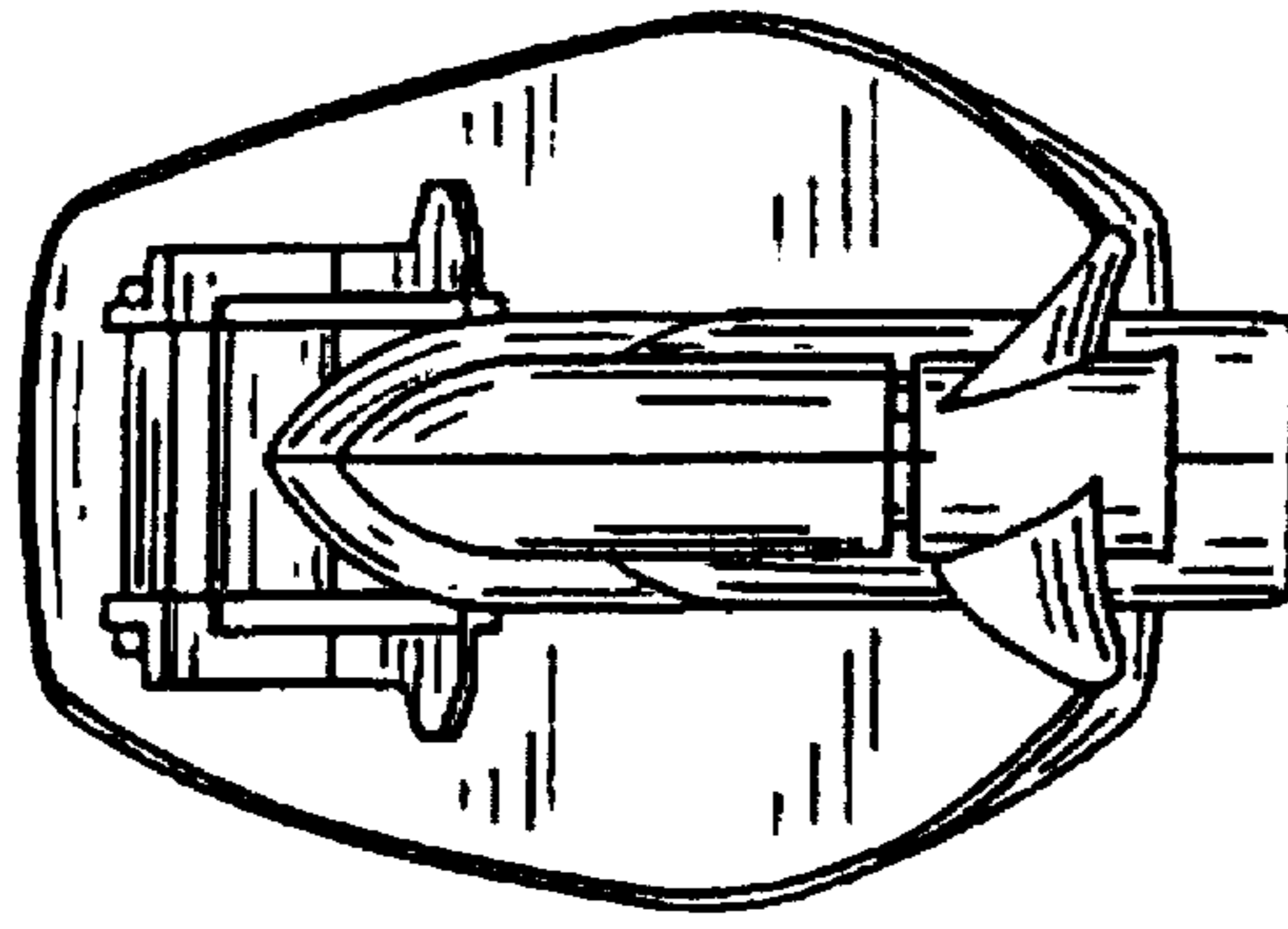

FIG. 3

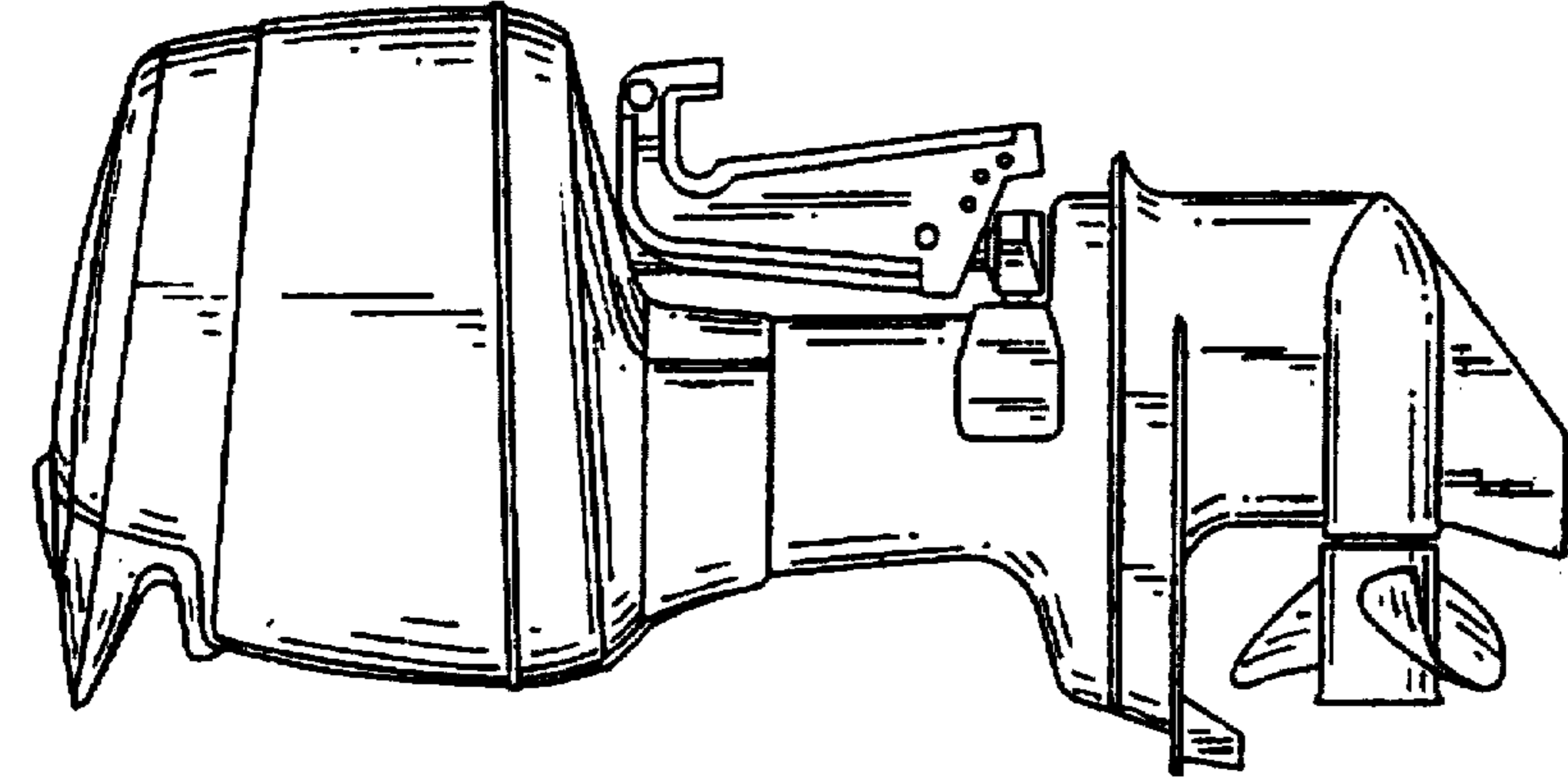

FIG. 4

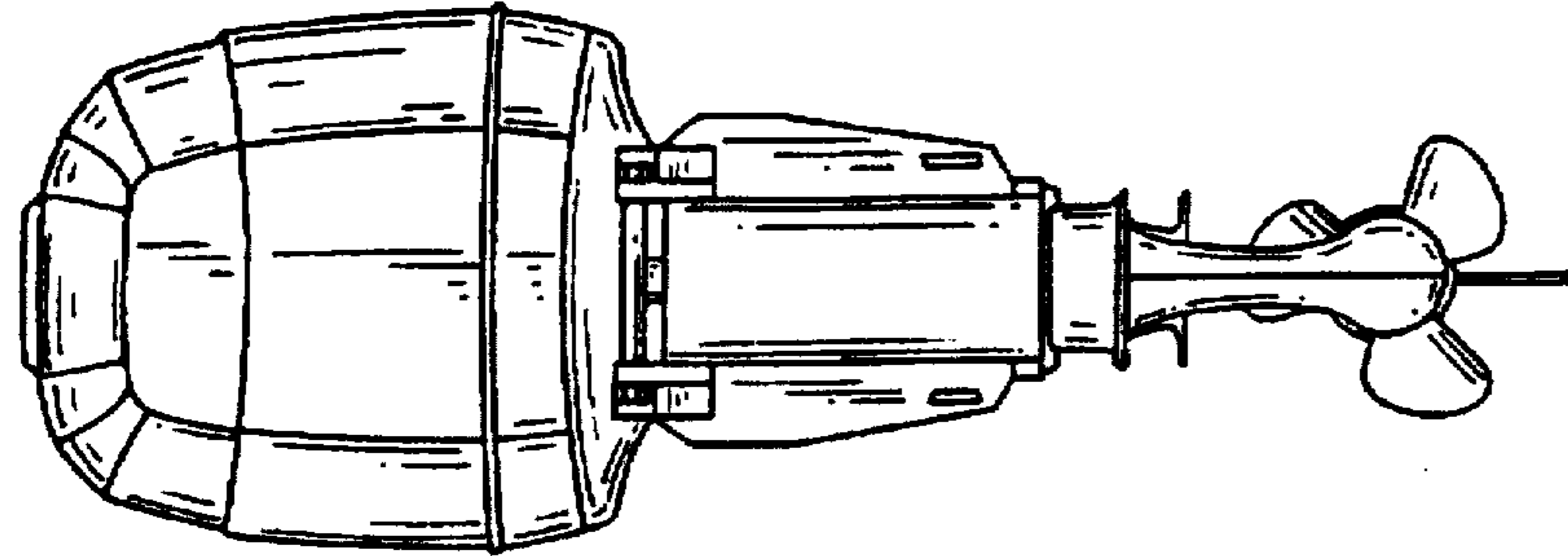

FIG. 5

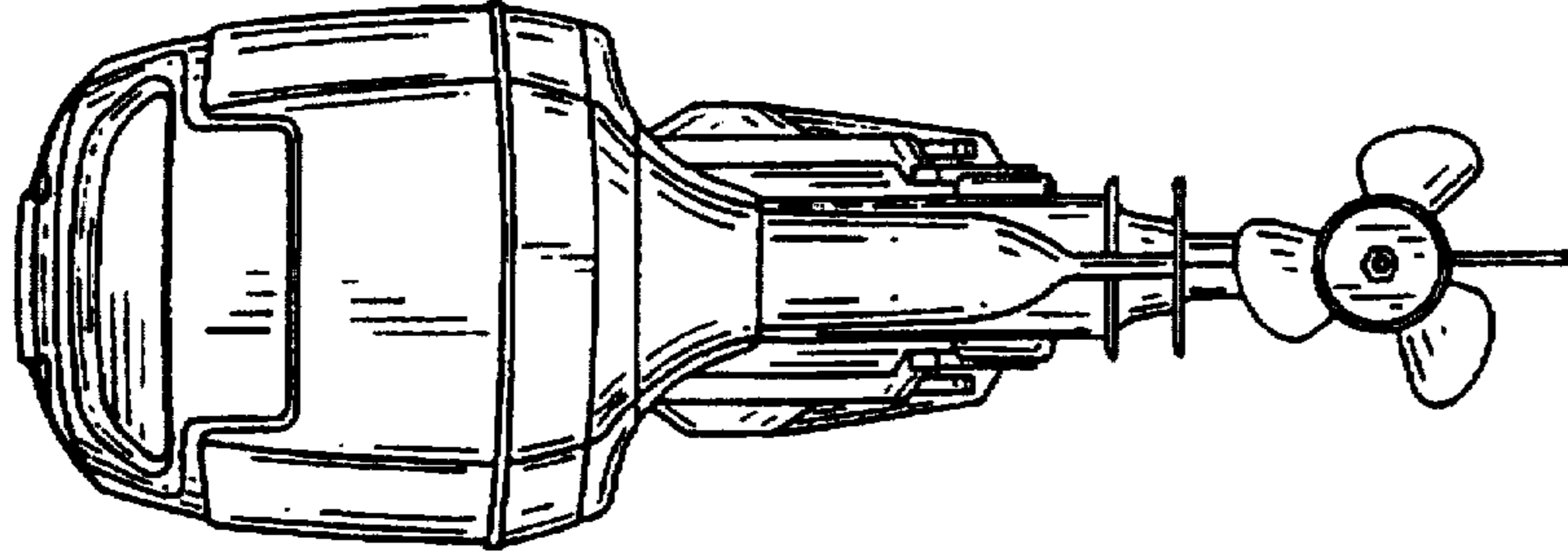

FIG. 6

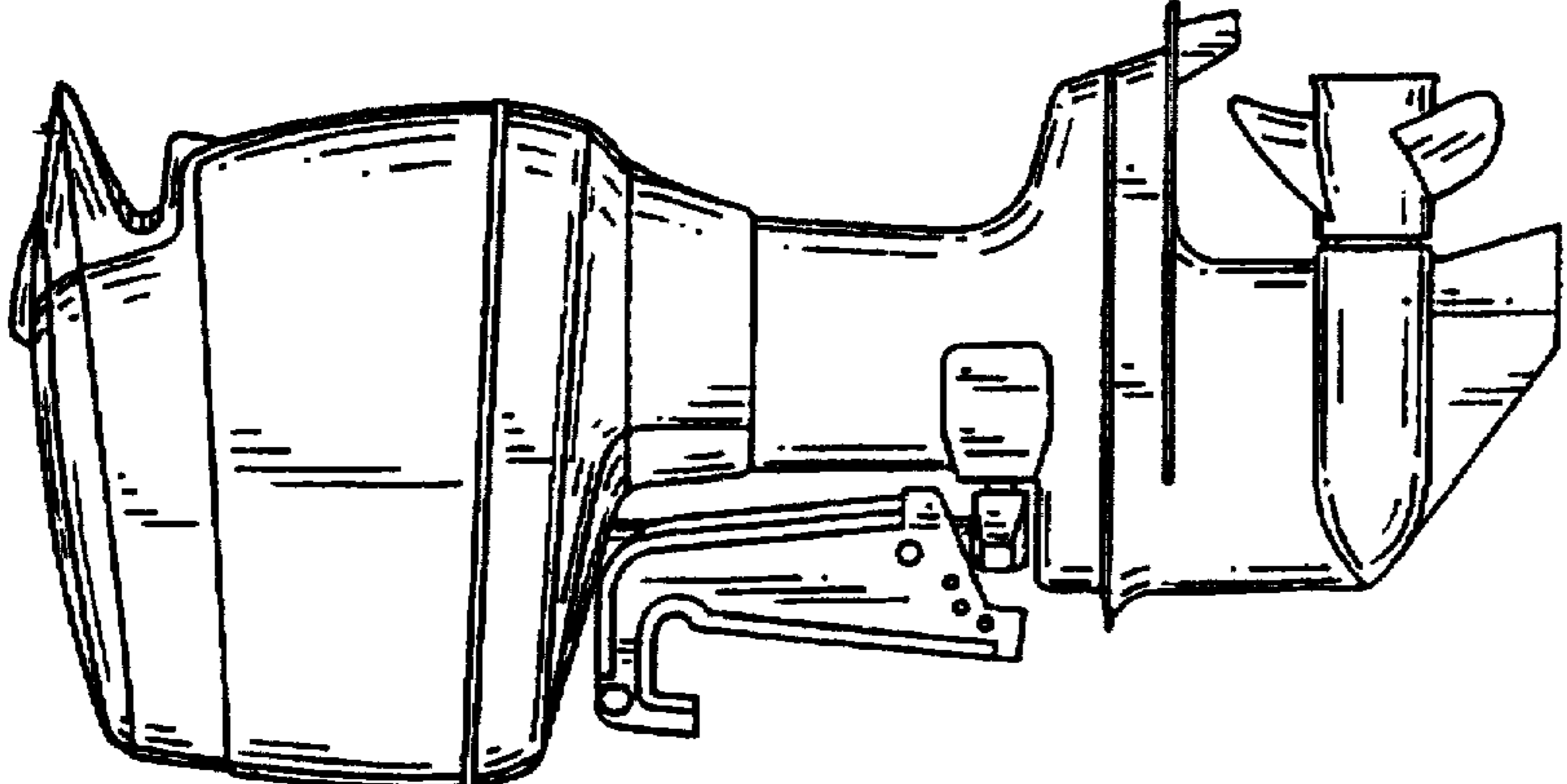

FIG. 7

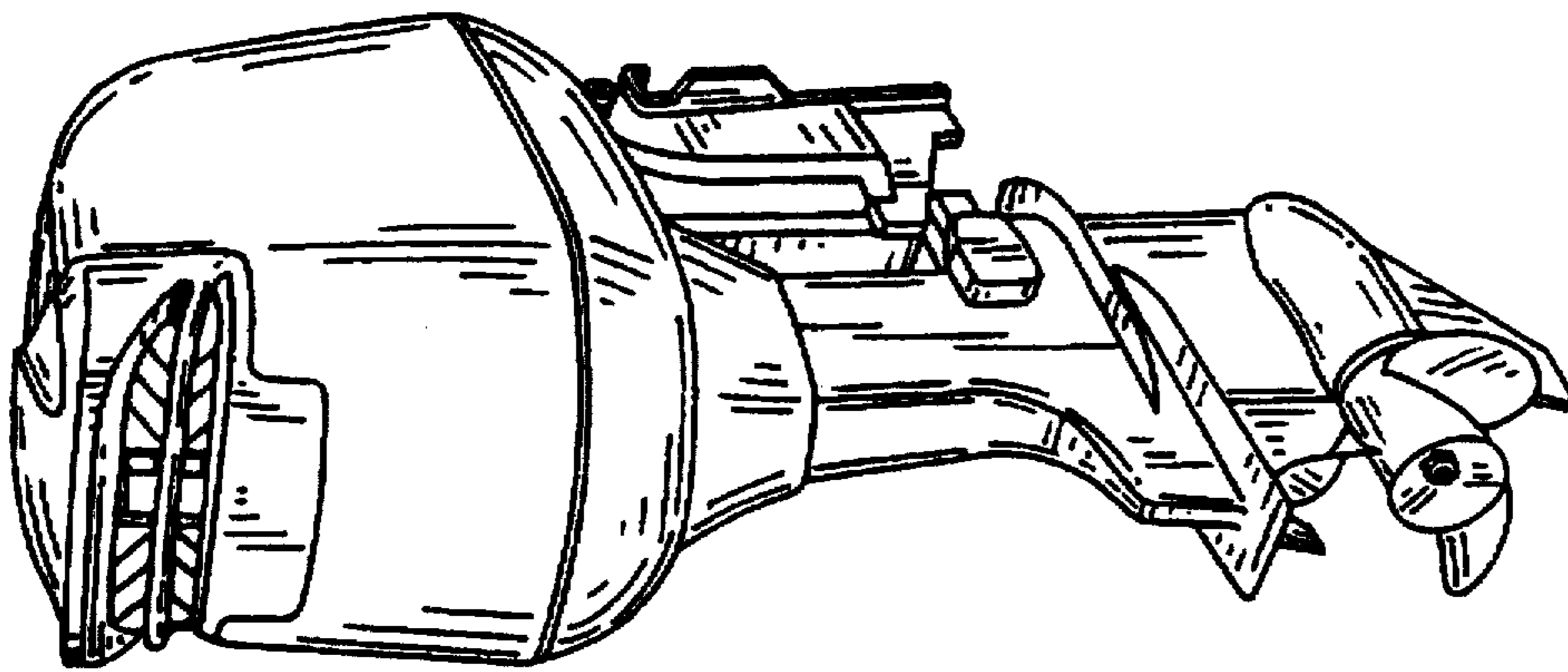

FIG. 8

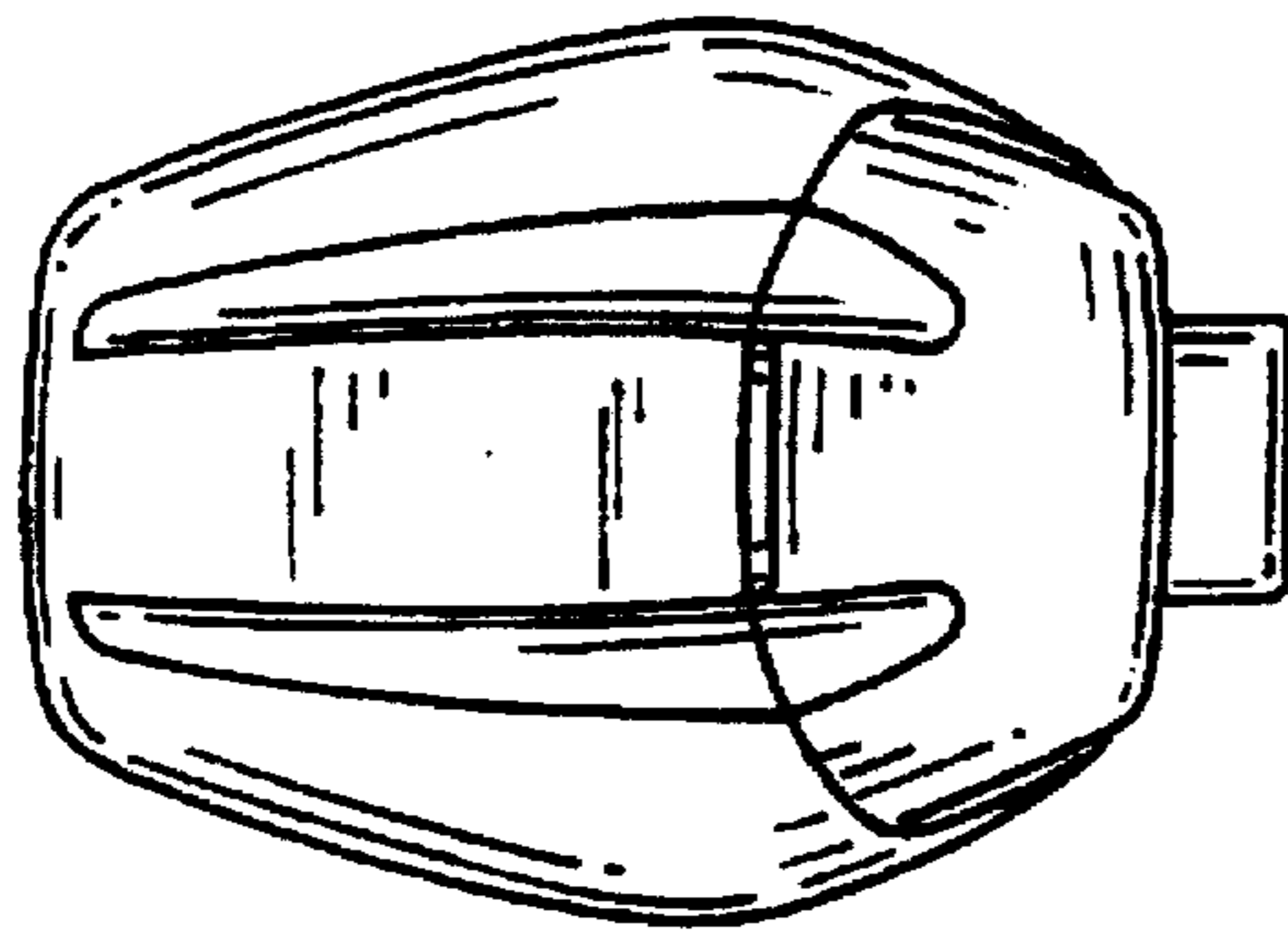

FIG. 9

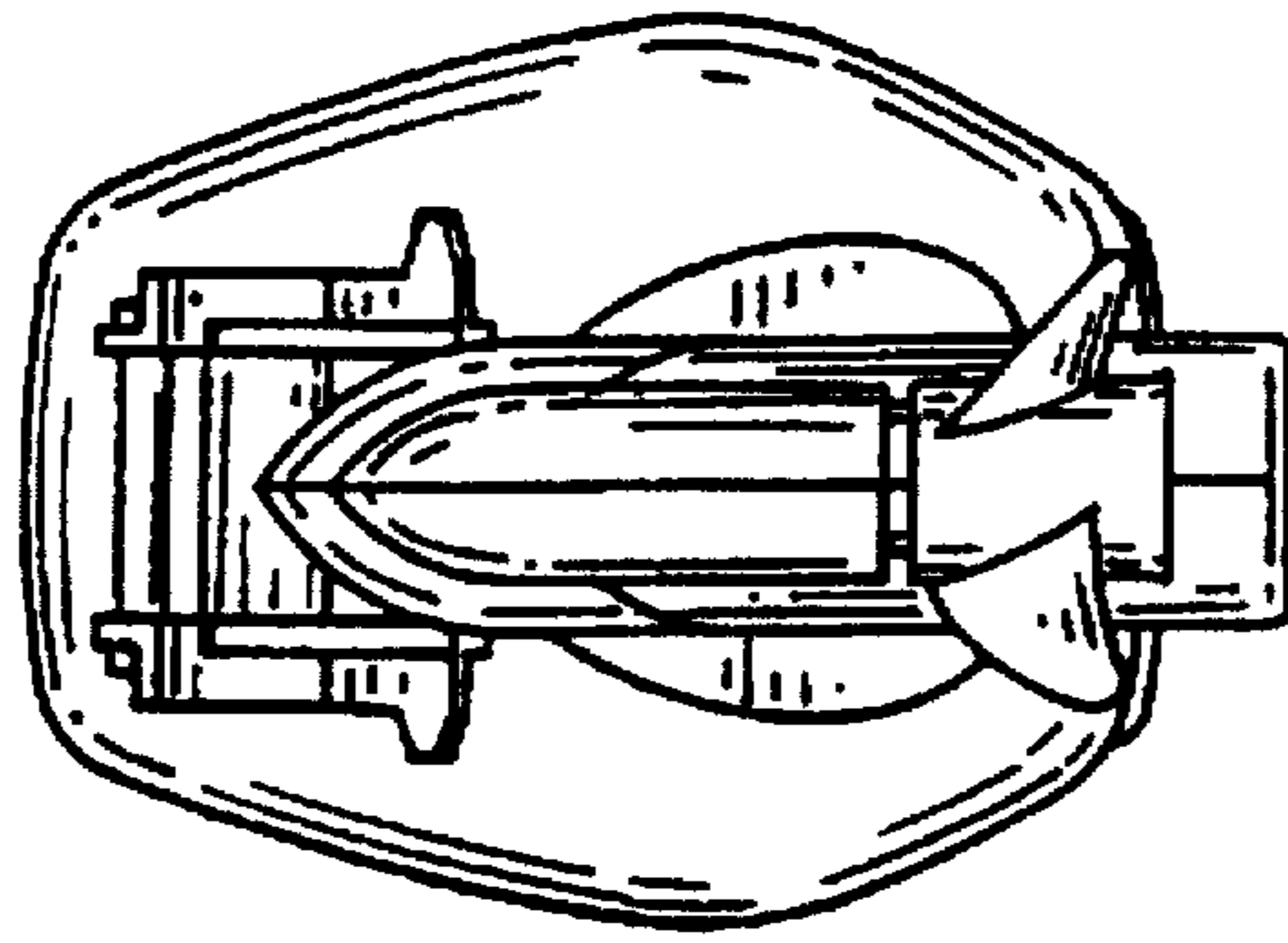

FIG. 10

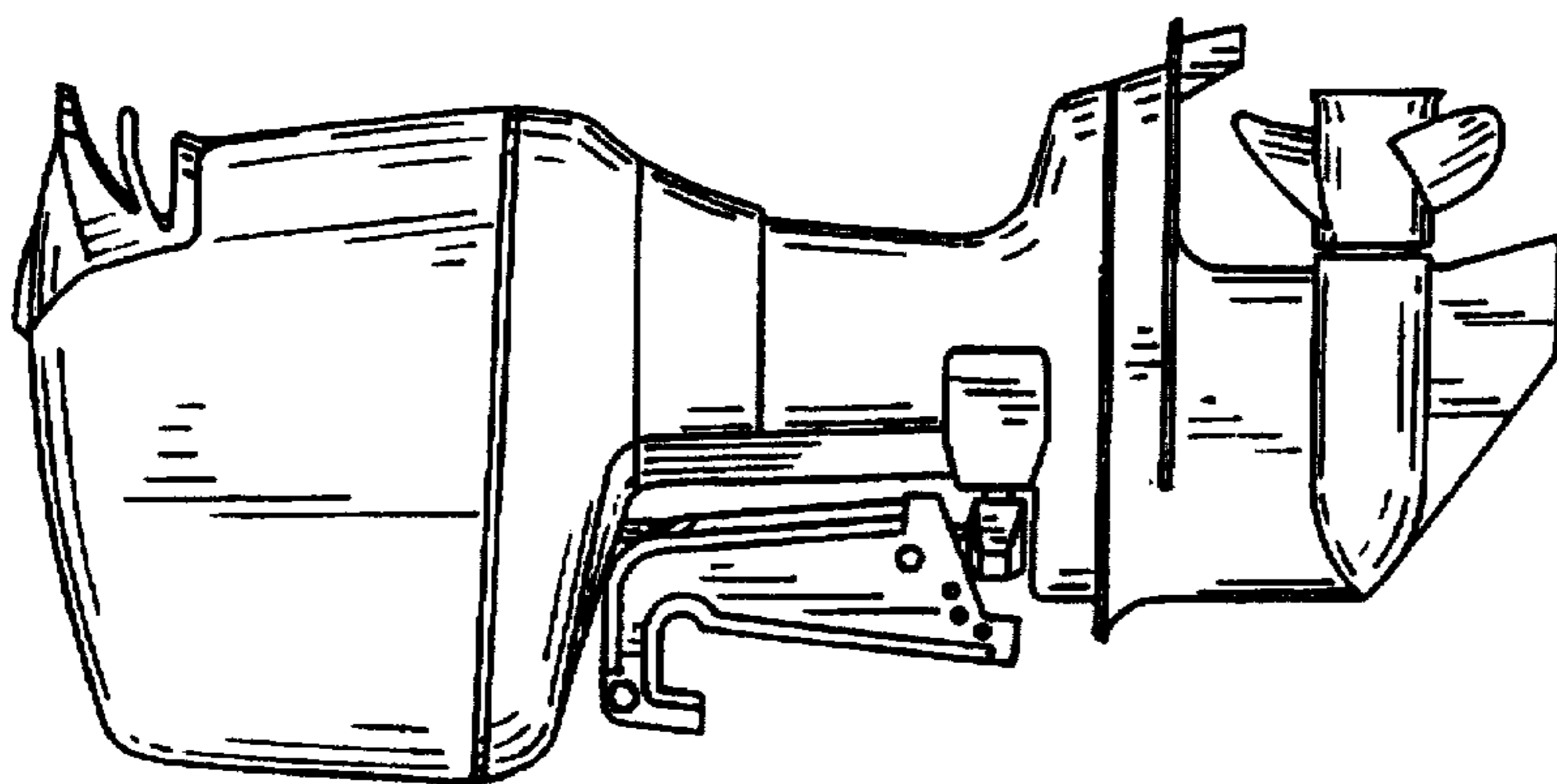

FIG.11

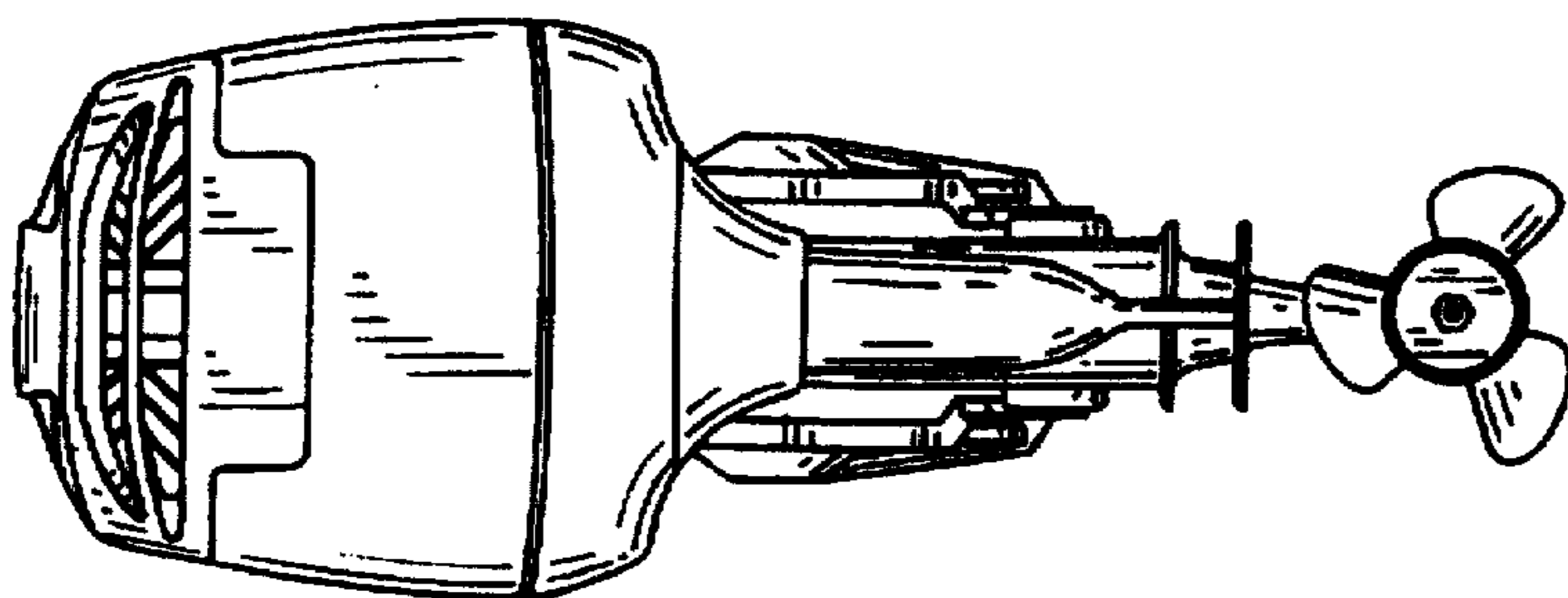

FIG.12

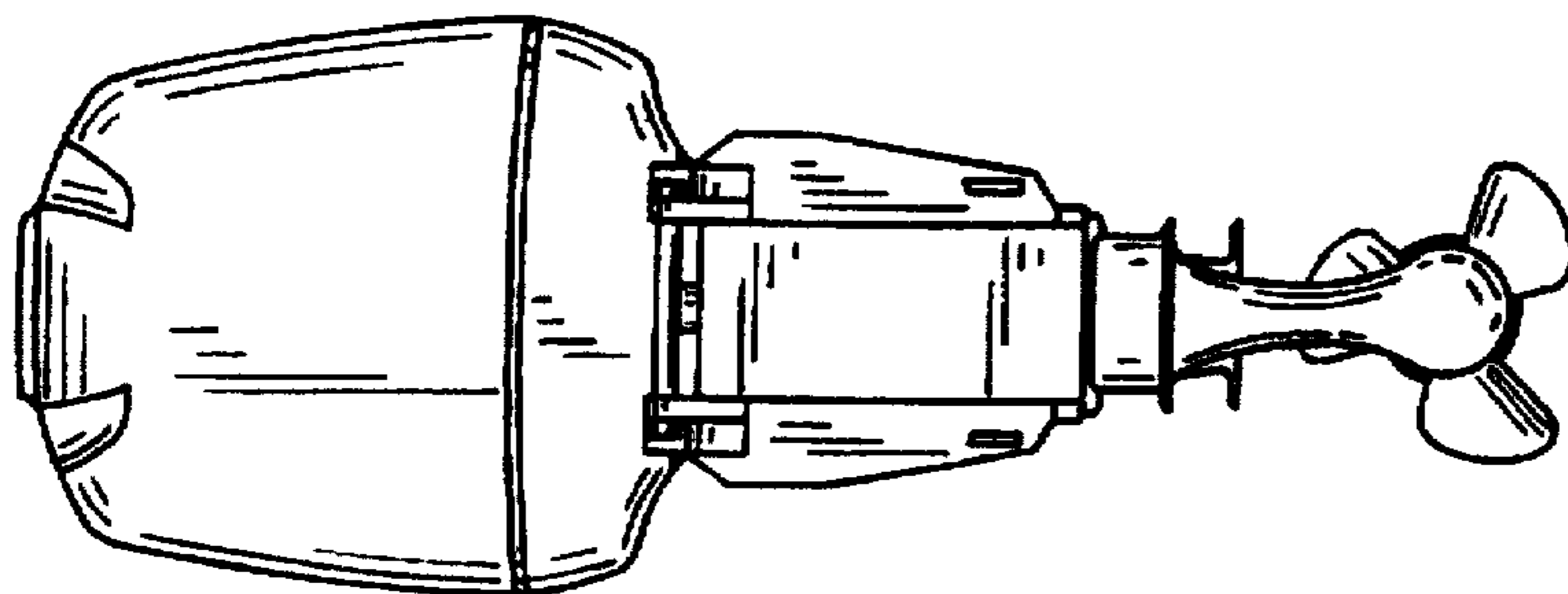

FIG.13

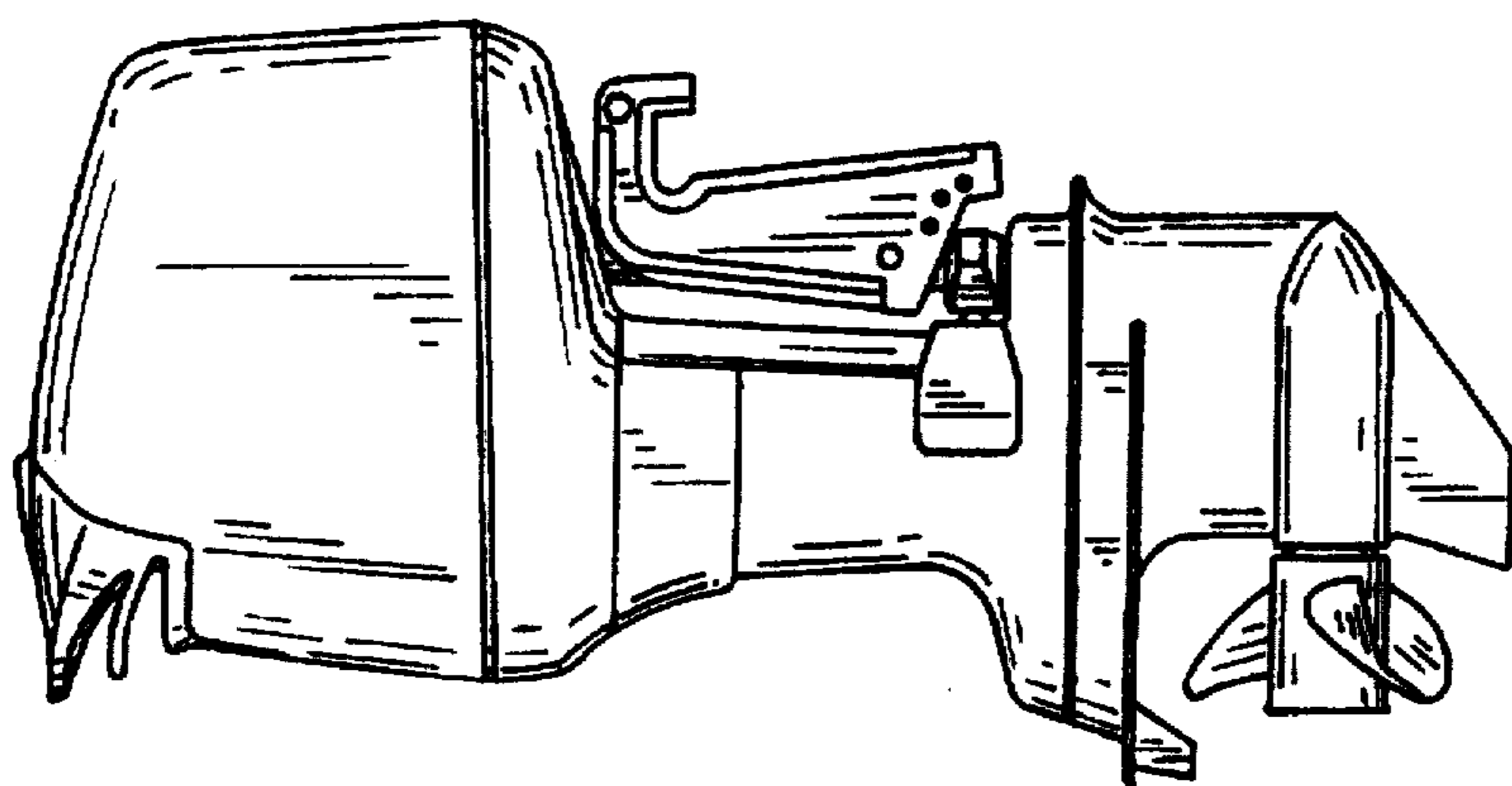

FIG.14