



US00D387423S

# United States Patent [19]

Nash et al.

[11] Patent Number: **Des. 387,423**

[45] Date of Patent: **\*\*Dec. 9, 1997**

[54] **AIR FILTRATION UNIT FOR AN EMERGENCY VEHICLE**

4,640,184	2/1987	Matsushima et al.	454/137
4,690,042	9/1987	Bertelsen et al.	55/472
4,763,564	8/1988	Czamecki et al.	454/139

[75] Inventors: **Rodney T. Nash**, Hutchinson, Kans.; **Ronald G. Lavicott**, Oviedo; **Herschel W. Davis**, Winter Springs, both of Fla.

*Primary Examiner*—Lisa Lichtenstein  
*Attorney, Agent, or Firm*—Shook, Hardy & Bacon L.L.P.

[73] Assignee: **Wheeled Coach Industries, Inc.**, Winter Park, Fla.

### [57] CLAIM

[\*\*] Term: **14 Years**

The ornamental design for an air filtration unit for an emergency vehicle, as shown and described.

[21] Appl. No.: **63,249**

### DESCRIPTION

[22] Filed: **Dec. 3, 1996**

FIG. 1 is a front elevation view of an air filtration unit for an emergency vehicle showing our new design; FIG. 2 is a slightly enlarged top, front perspective view thereof; FIG. 3 is a slightly enlarged front elevation view thereof; FIG. 4 is a slightly enlarged side elevation view thereof; FIG. 5 is a slightly enlarged top plan view thereof; FIG. 6 is a slightly enlarged rear elevation view thereof; and, FIG. 7 is a slightly enlarged side elevation view showing the opposite side thereof.

[51] LOC (6) Cl. .... **23-04**

[52] U.S. Cl. .... **D23/365; D23/364**

[58] Field of Search ..... **D23/364, 365, D23/355; 454/137, 139, 158; 55/472**

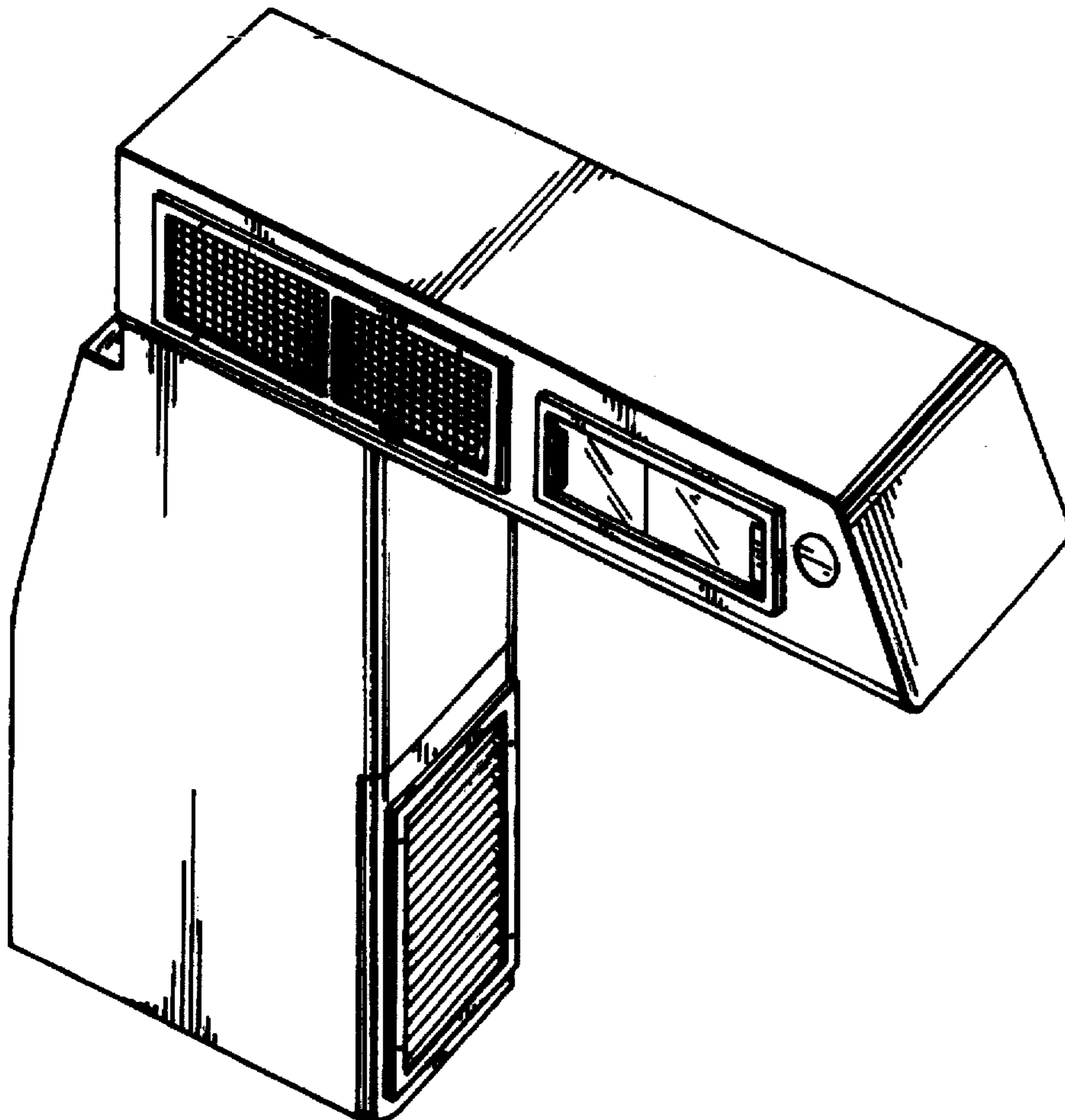
The fragmentary, broken line showing of an interior of the emergency vehicle in FIG. 1 of the drawing is for illustrative purposes only and forms no part of the claimed design.

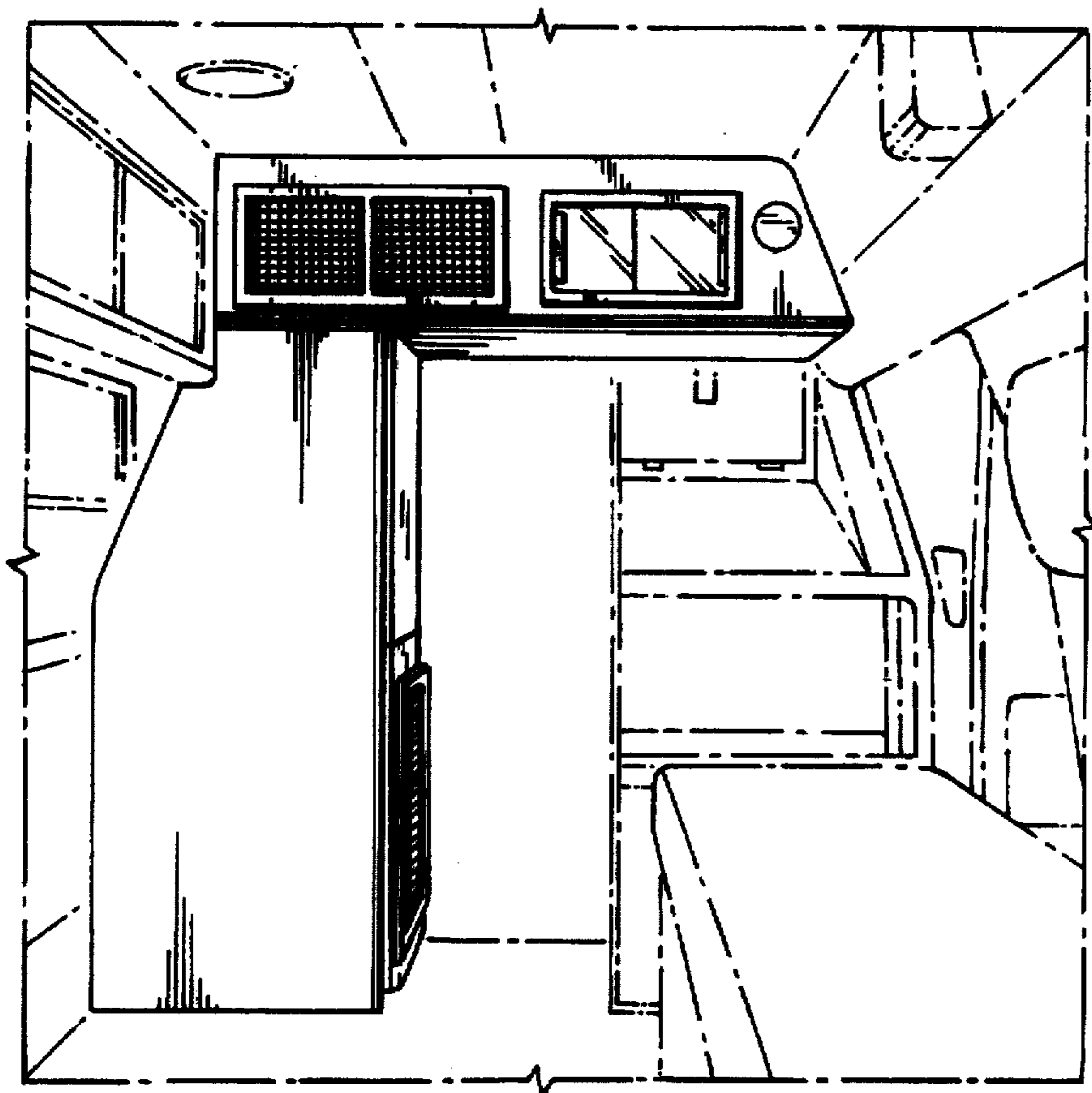
### [56] References Cited

#### U.S. PATENT DOCUMENTS

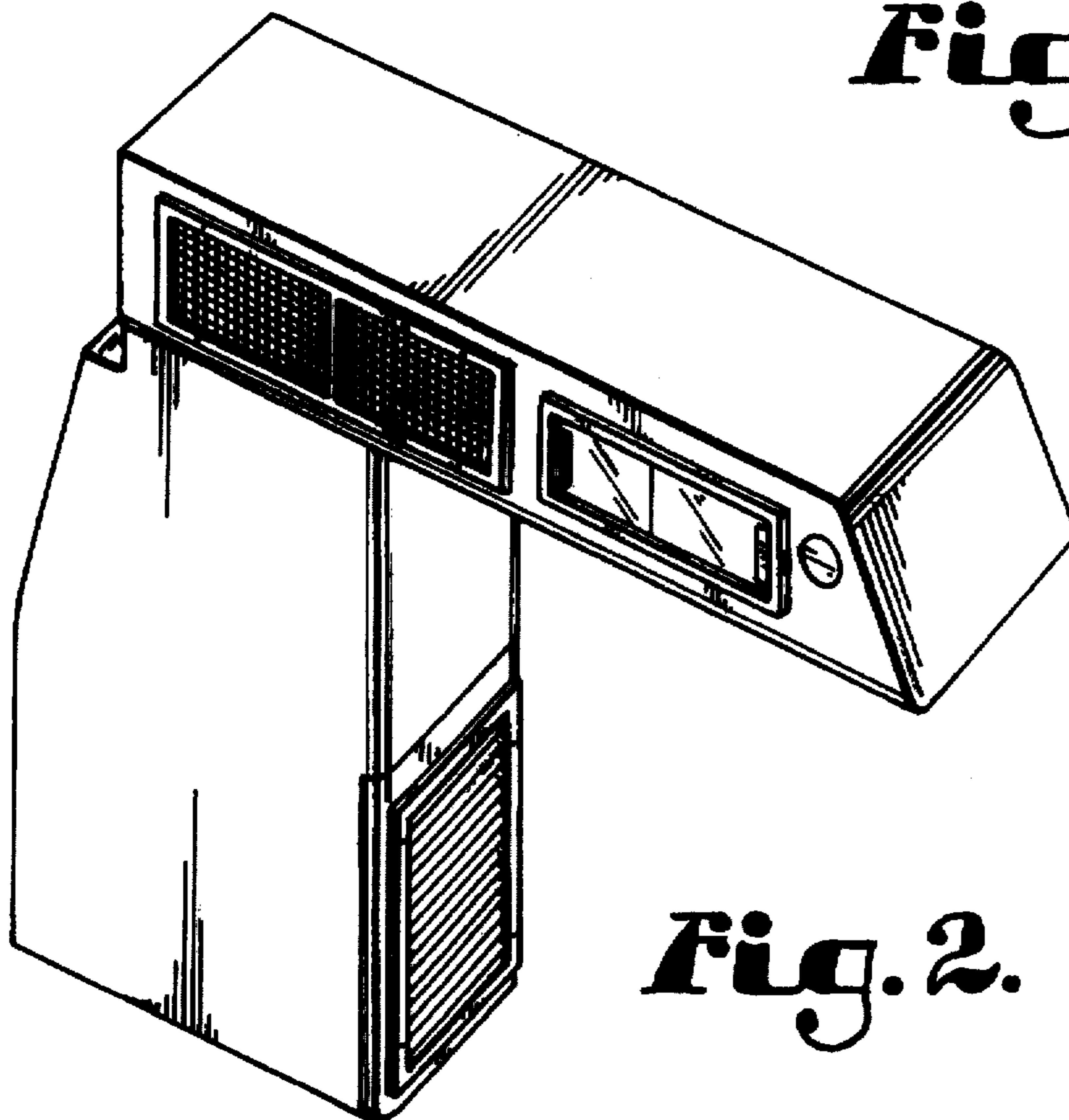
2,528,301	10/1950	Doe	55/467
3,616,624	11/1971	Marsh	55/472
4,172,865	10/1979	Steier	55/472
4,531,956	7/1985	Howorth	55/472

**1 Claim, 3 Drawing Sheets**

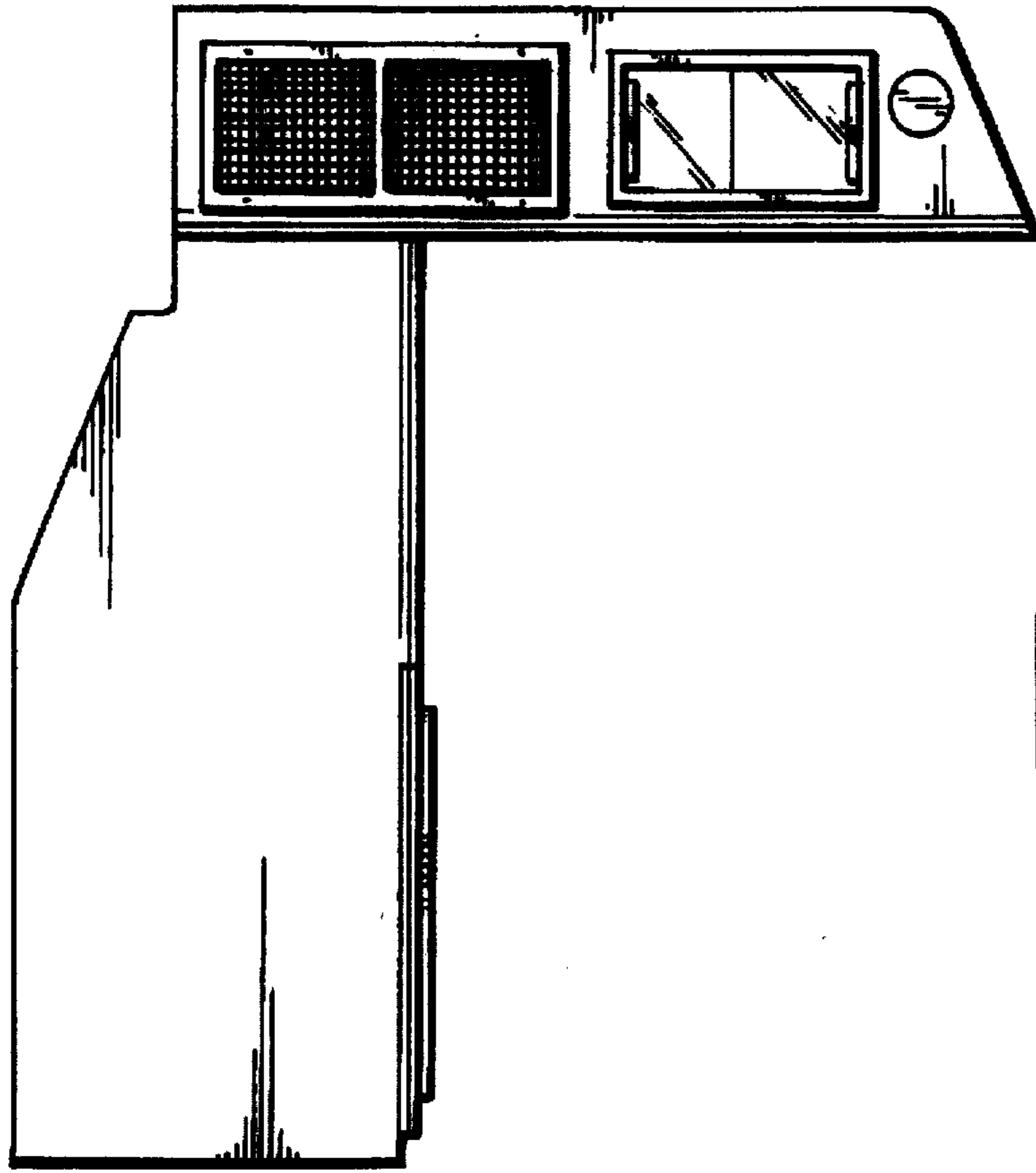




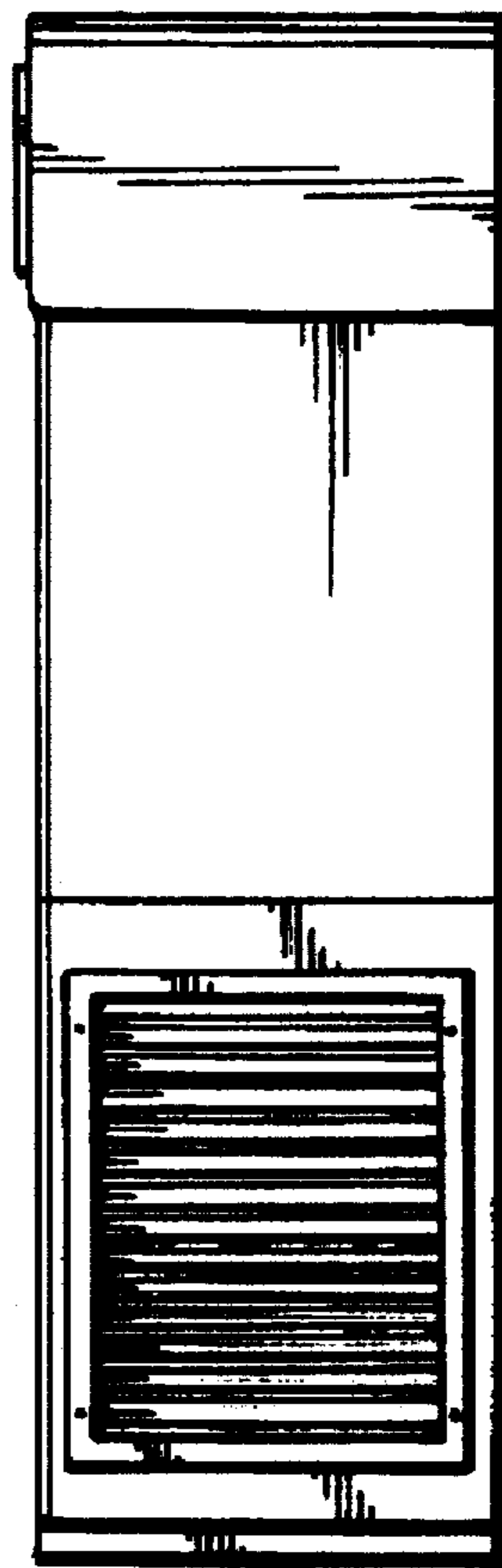
*Fig. 1.*



*Fig. 2.*

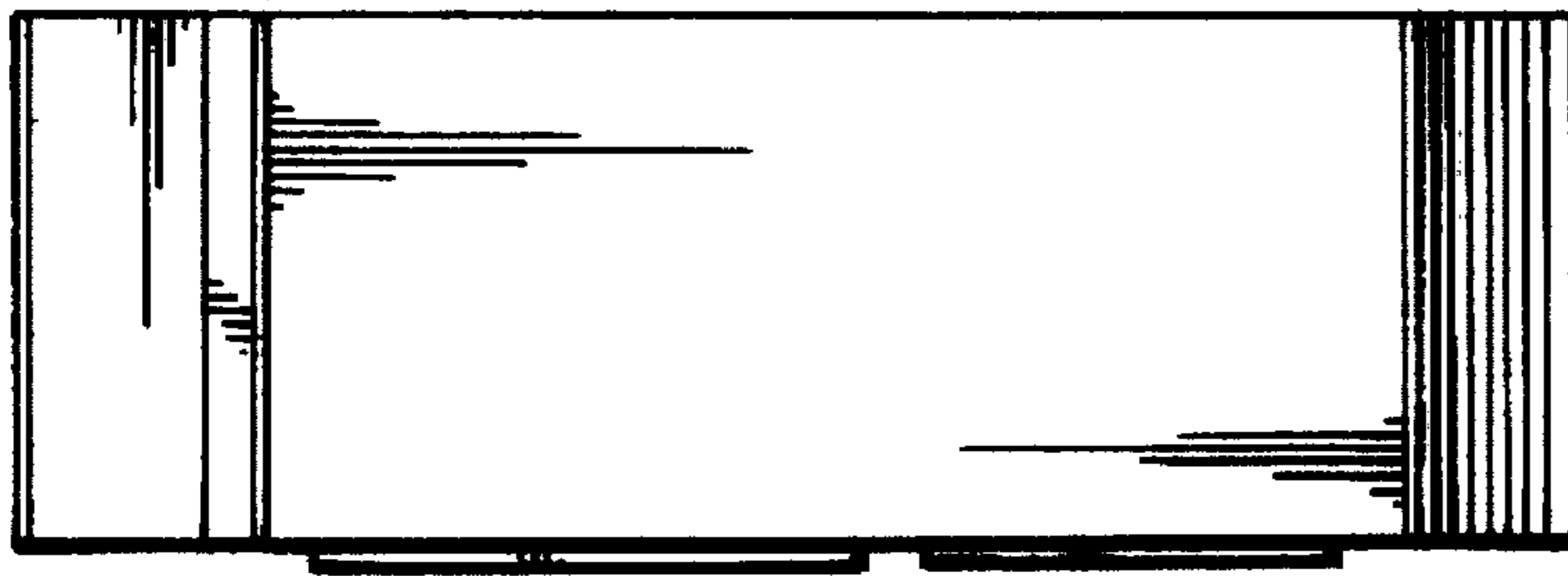


**Fig. 3.**

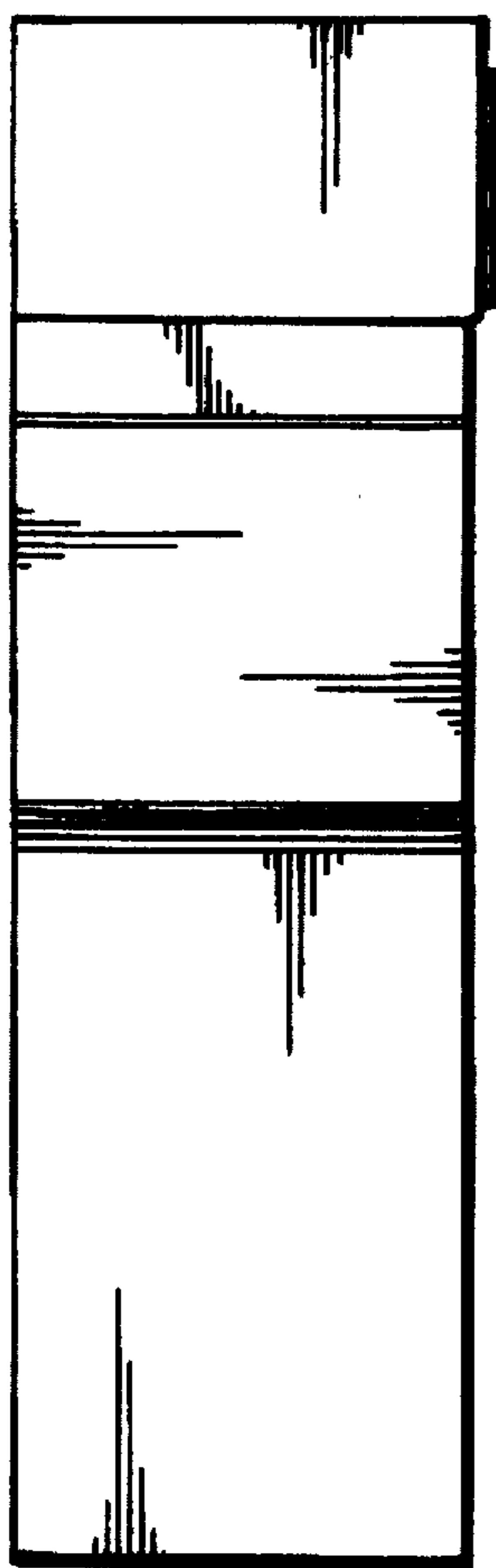
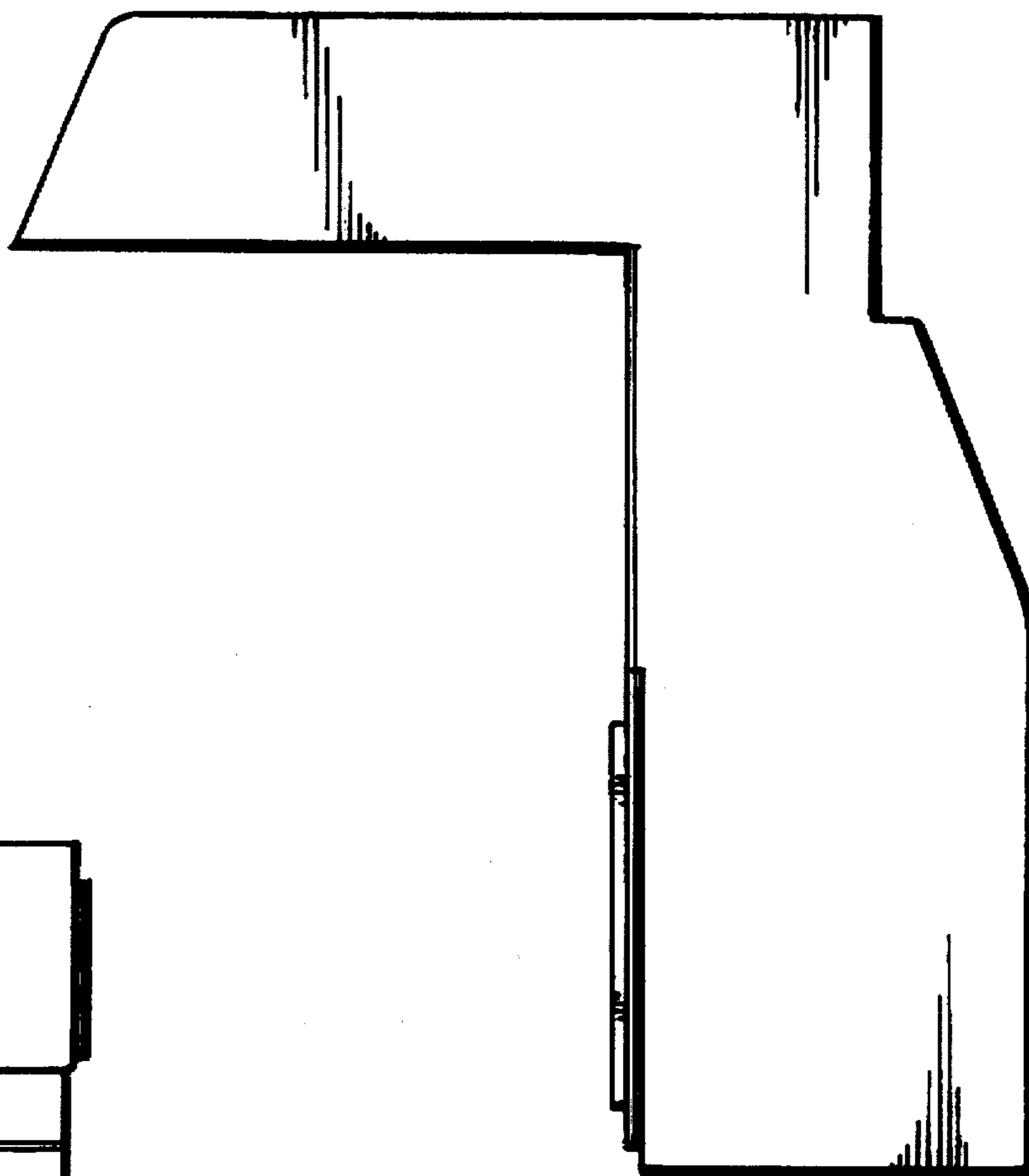


**Fig. 4.**

**Fig. 5.**



**Fig. 6.**



**Fig. 7.**