

US00D387252S

United States Patent [19]

Rimback et al.

[11] Patent Number: **Des. 387,252**

[45] Date of Patent: ****Dec. 9, 1997**

[54] **LANDSCAPE TIMBER CONNECTING SYSTEM MEMBER**

[75] Inventors: **Peter Rimback**, Cuyahoga County;
James Vidmar, Willoughby, both of Ohio

[73] Assignee: **Hanover Catalog Holdings, Inc.**, Weehawken, N.J.

[**] Term: **14 Years**

[21] Appl. No.: **55,285**

[22] Filed: **May 31, 1996**

[51] LOC (6) Cl. **08-01**

[52] U.S. Cl. **D8/1; D8/382**

[58] Field of Search D8/1, 354, 356, D8/382, 384, 394; D25/35, 113, 118, 131, 133, 199, 164; 47/23, 33, 41.14; 52/102, 103, 155, 156, 590.2, 653.2; 403/65, 205, 93, 169, 170, 217, 381

[56] **References Cited**

U.S. PATENT DOCUMENTS

D. 277,727	2/1985	Klaric	D8/382
1,898,297	2/1933	Fox	D25/113 X
2,794,375	6/1957	Di Falco et al.	47/33 X
3,343,301	9/1967	Adelman	D25/113 X
3,537,687	11/1970	Adelman	256/19
3,545,128	12/1970	La Fontaine et al.	47/33

3,916,563	11/1975	Tedesh	47/33
4,884,920	12/1989	Perazzi	47/33 X
4,971,475	11/1990	Castonguay et al.	404/7
5,168,678	12/1992	Scott, Jr. et al.	52/102
5,230,187	7/1993	Reimann	52/102
5,291,703	3/1994	Johnson	52/103

Primary Examiner—Caron D. Veynar
Attorney, Agent, or Firm—Thompson Hine & Flory LLP

[57] **CLAIM**

The ornamental design for a landscape timber connecting system member, as shown and described.

DESCRIPTION

FIG. 1 is a front, right and top perspective view of a landscape timber connecting system member embodying our new design, the broken line showing of a second member is for illustrative purposes only and forms no part of the claimed design;

FIG. 2 is a perspective view thereof;

FIG. 3 is an exploded perspective view thereof;

FIG. 4 is an exploded perspective view thereof, taken from below and to the right;

FIG. 5 is a top plan view thereof;

FIG. 6 is a right side elevational view thereof, the left side elevational view being a mirror image;

FIG. 7 is a bottom plan view thereof;

FIG. 8 is a front elevational view thereof; and,

FIG. 9 is a rear elevational view thereof.

1 Claim, 4 Drawing Sheets

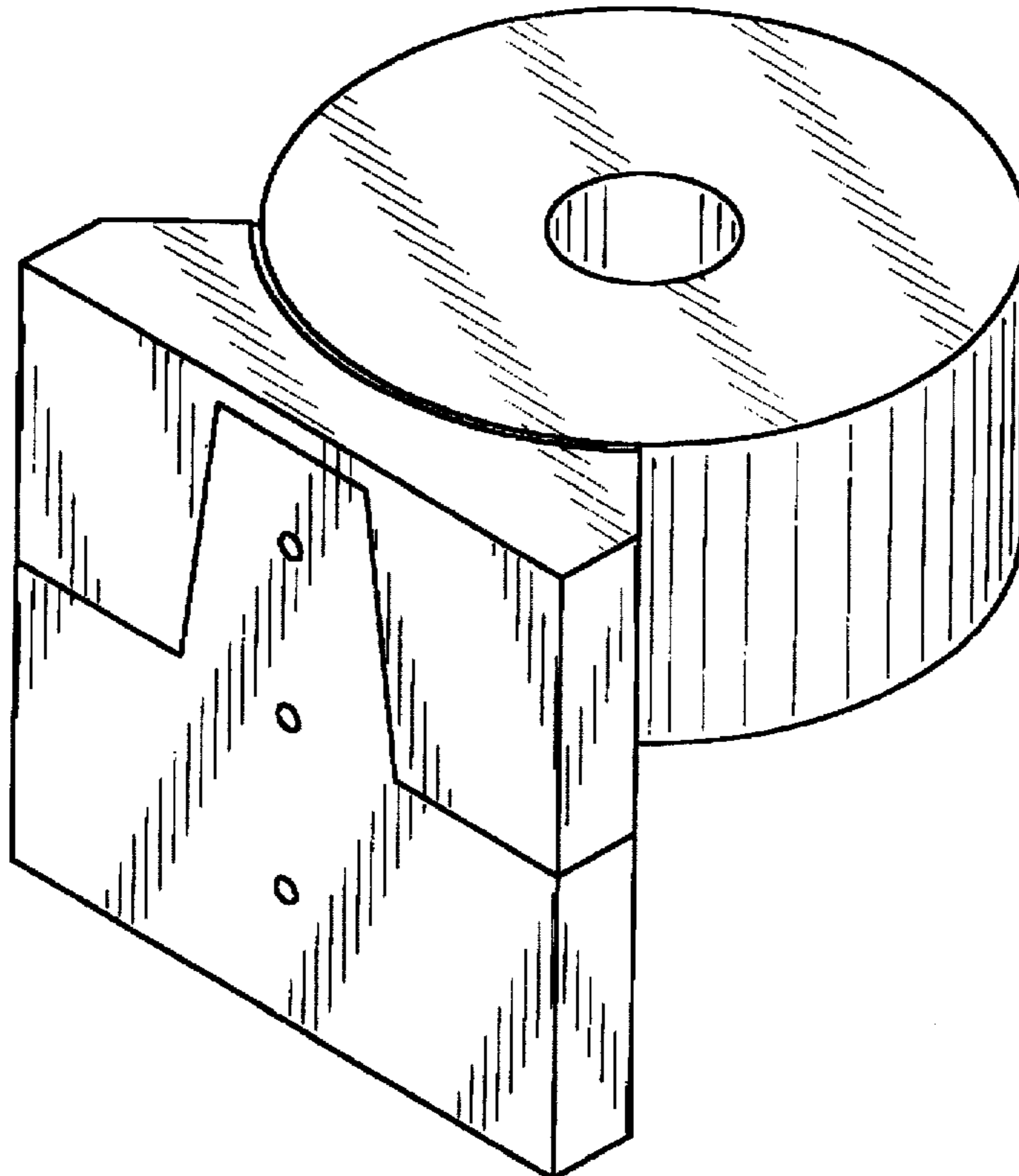

FIG. 1

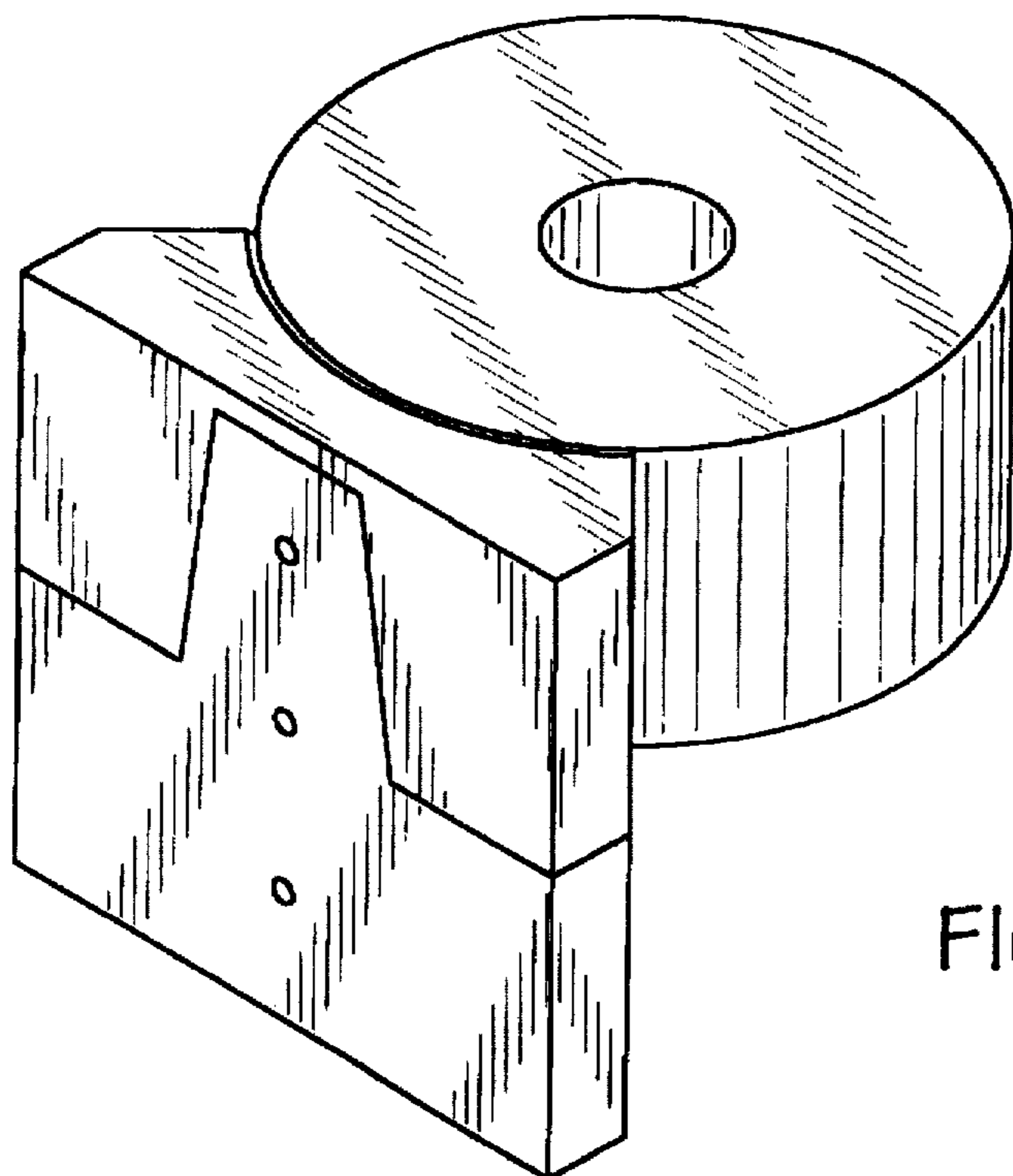
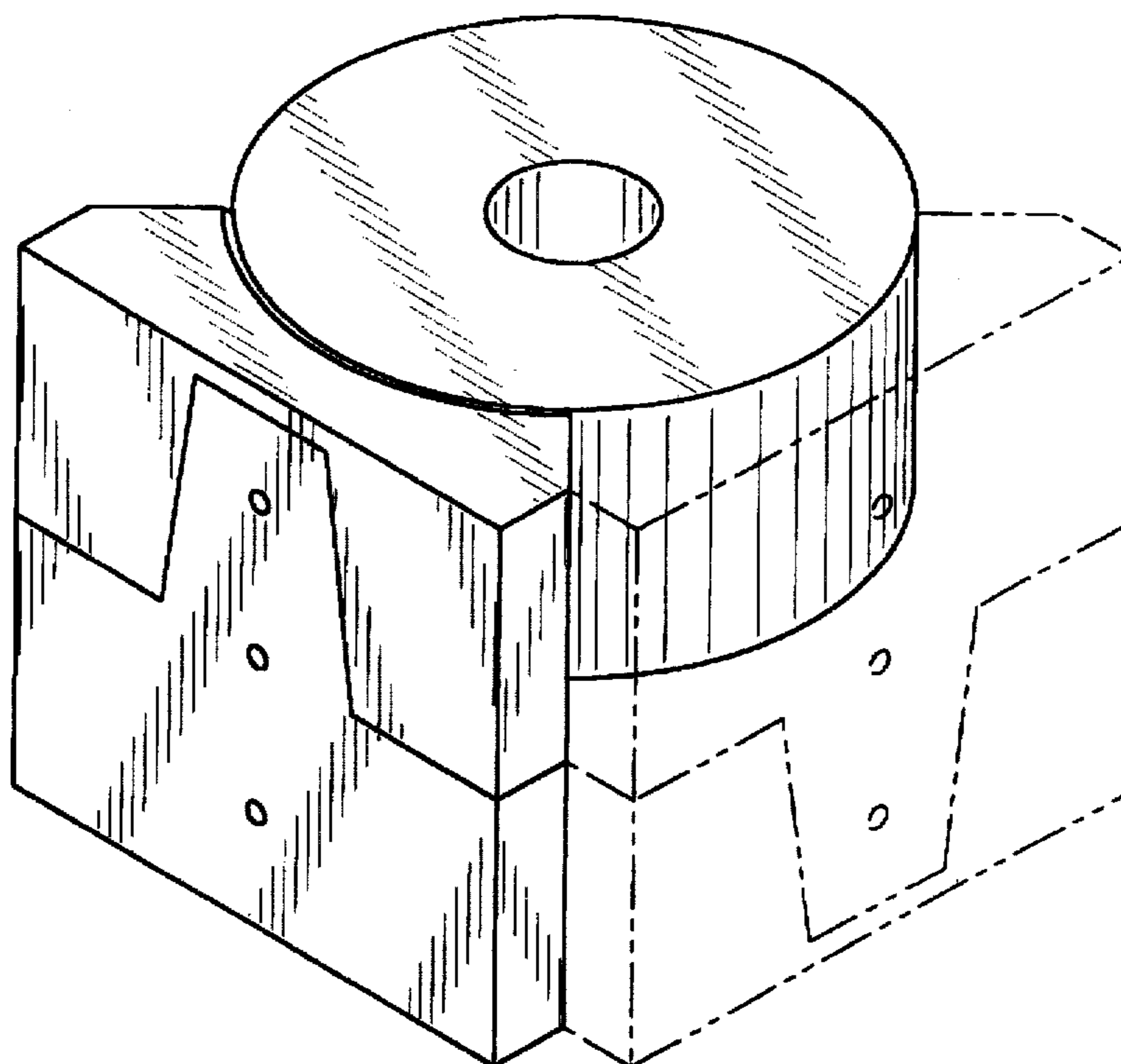

FIG. 2

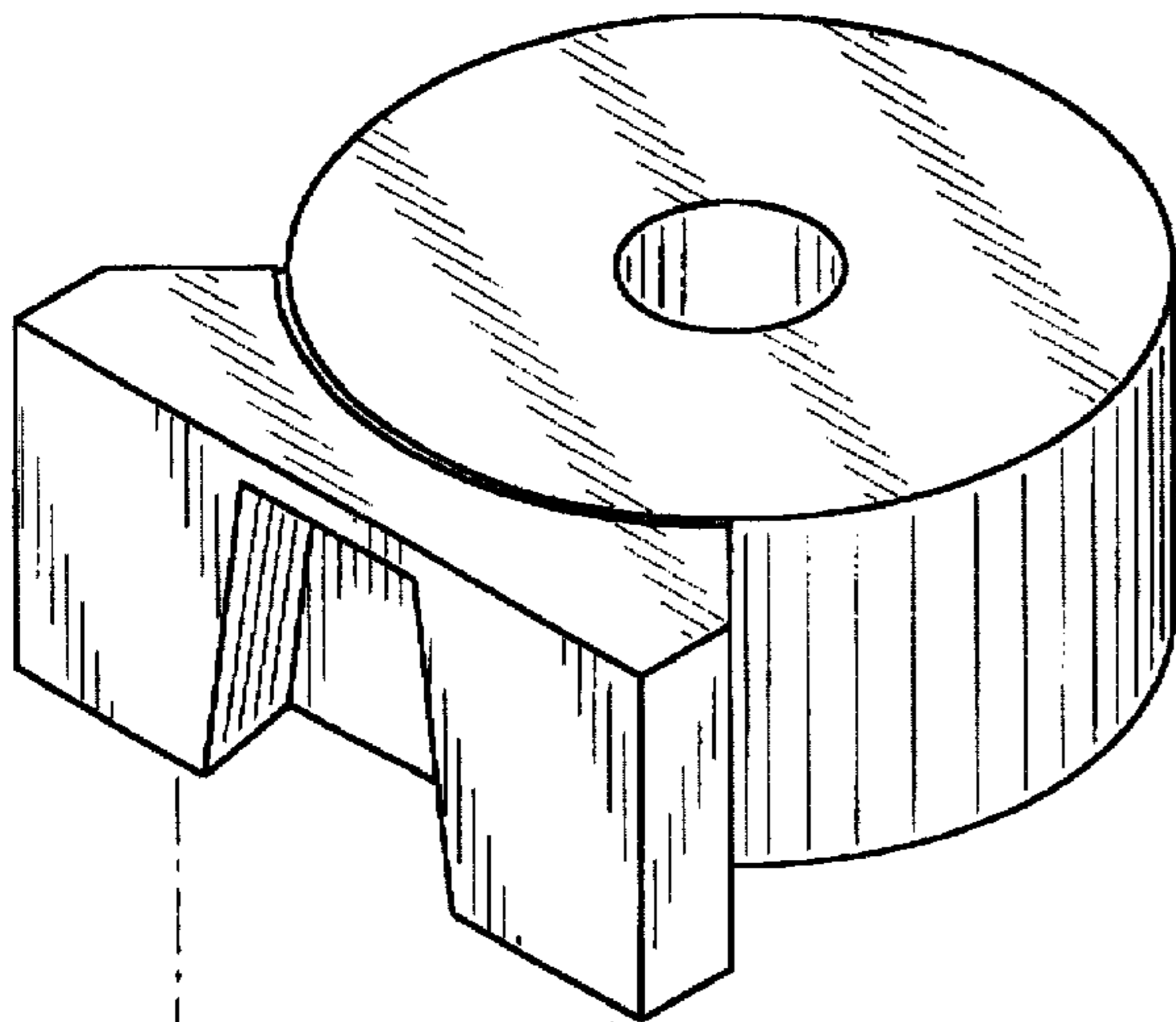

FIG. 3

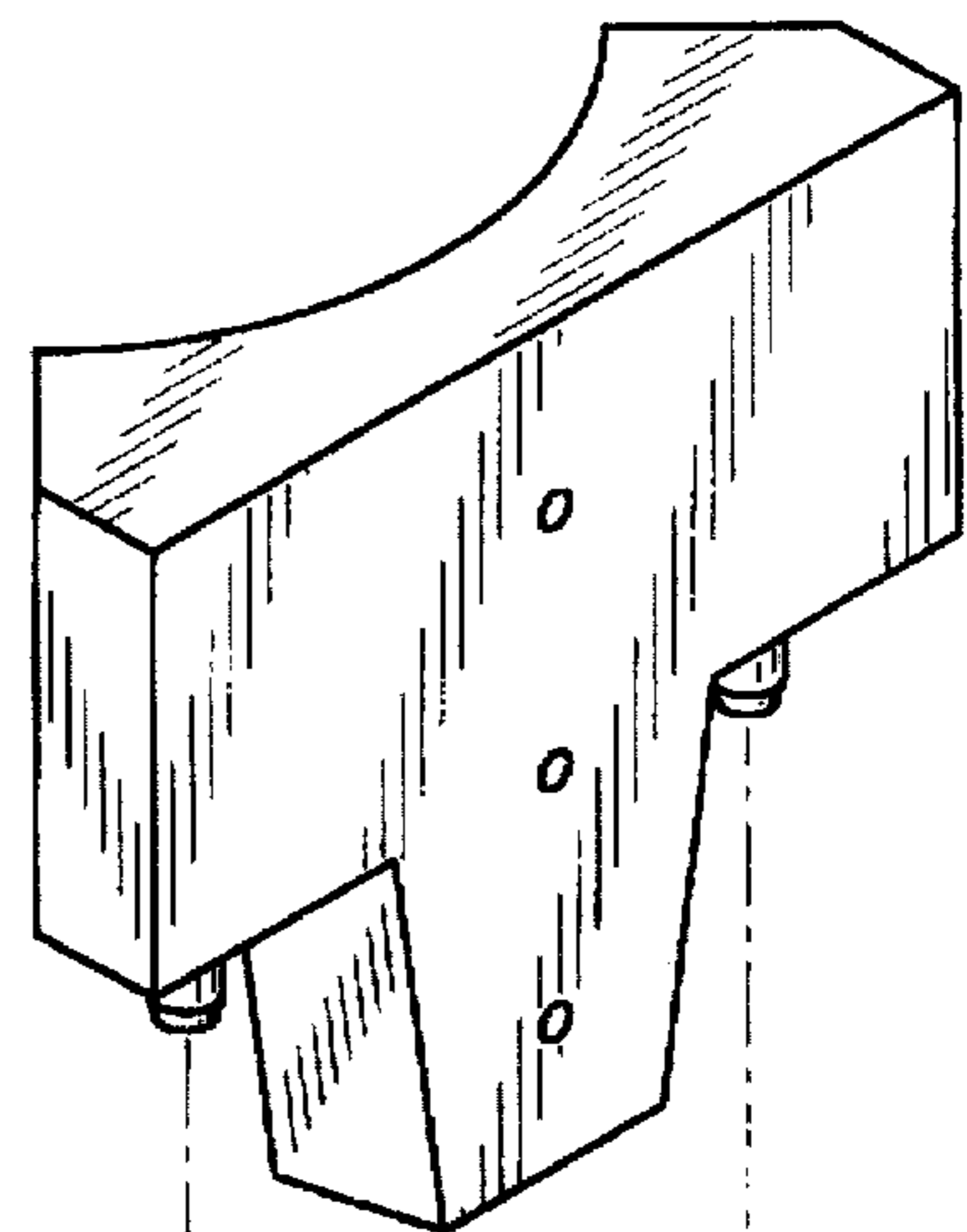
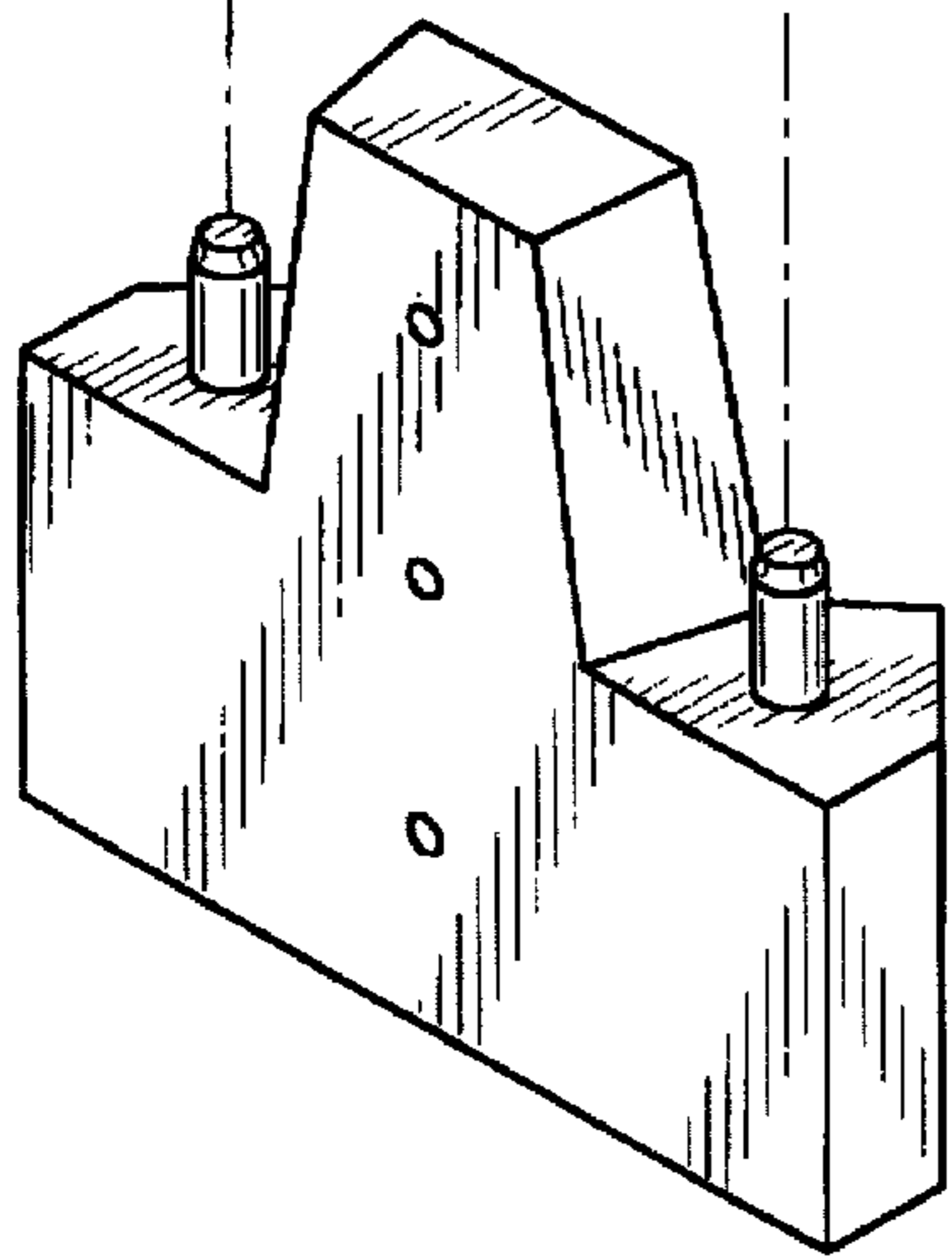
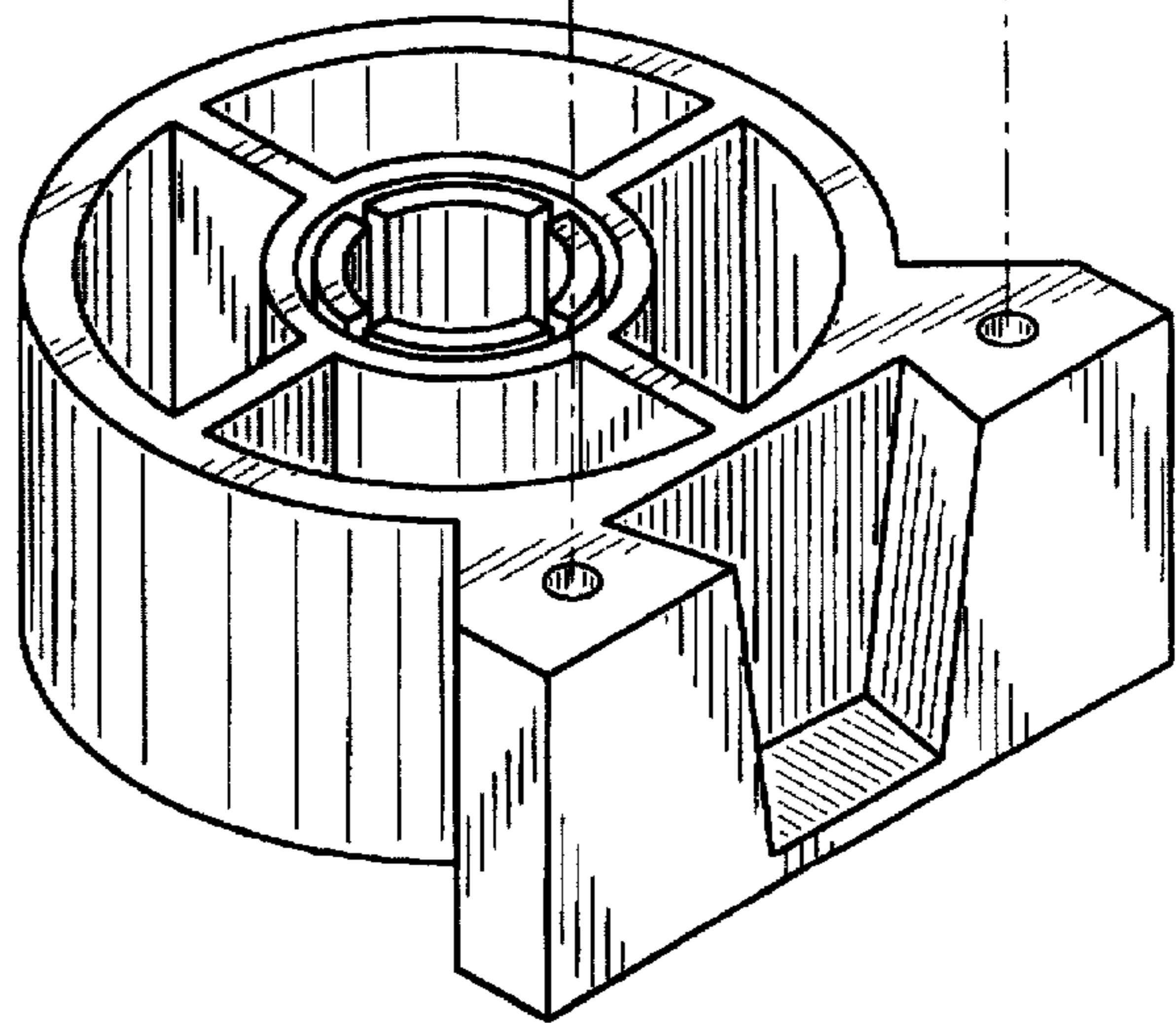

FIG. 4



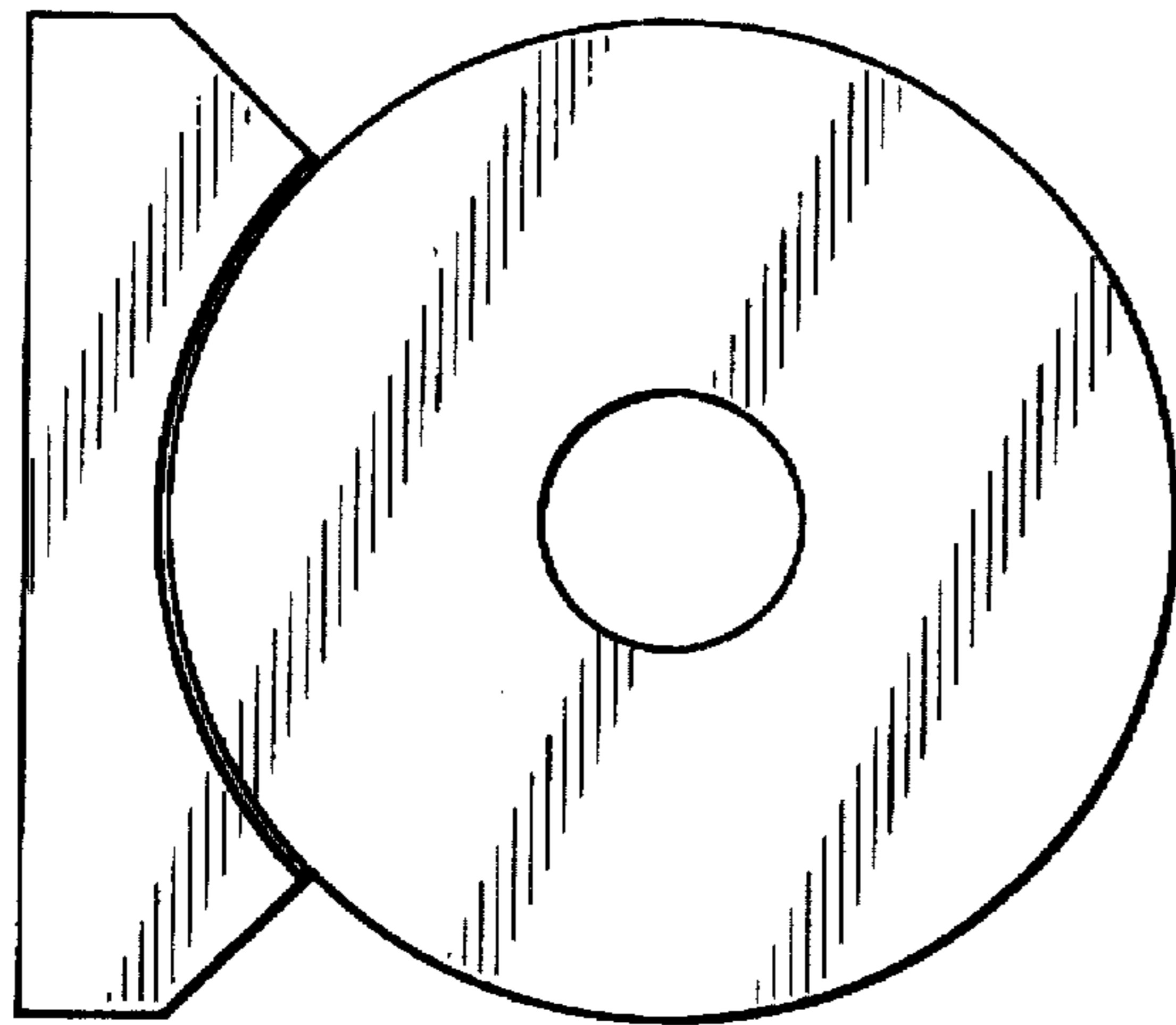

FIG. 5

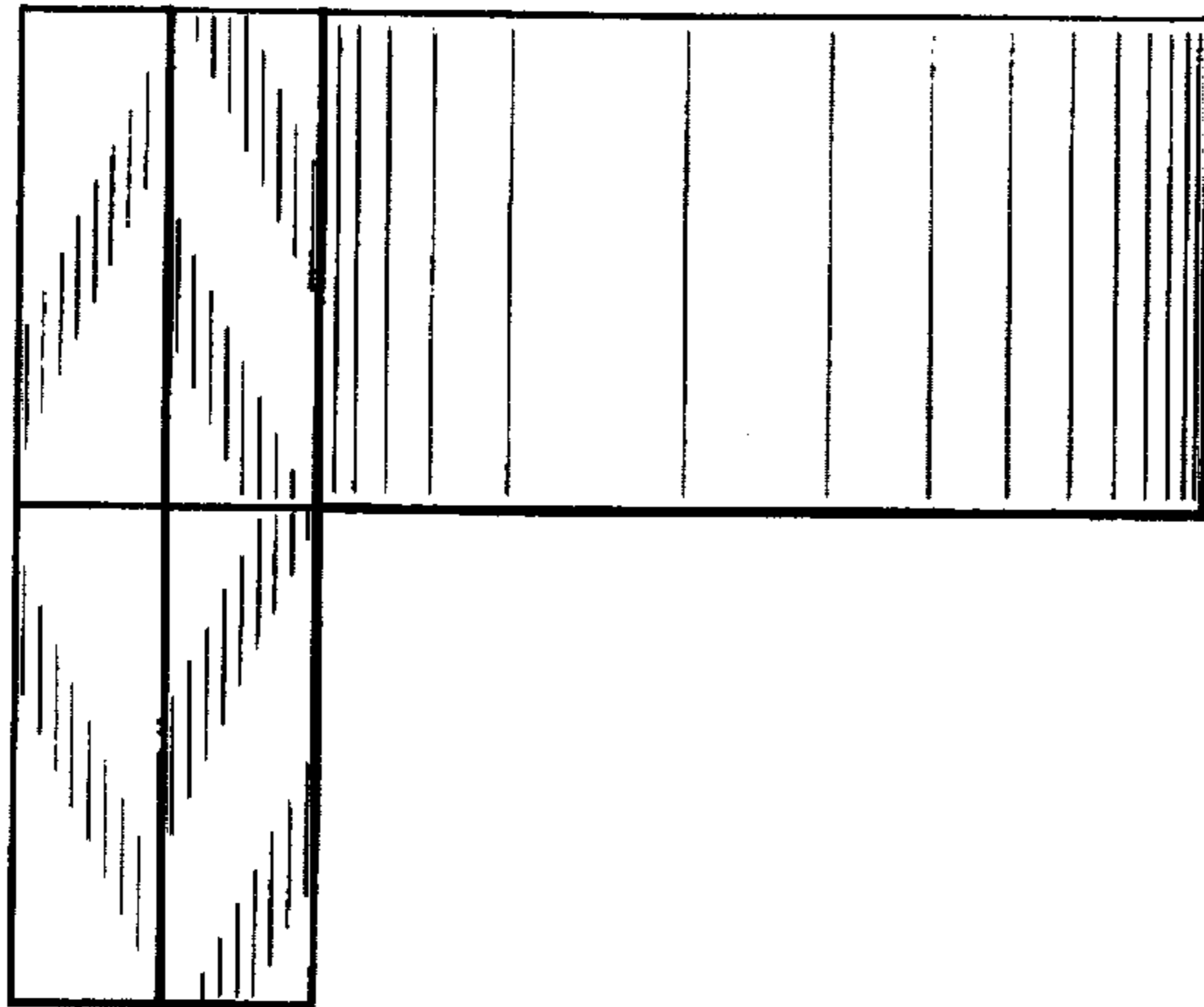

FIG. 6

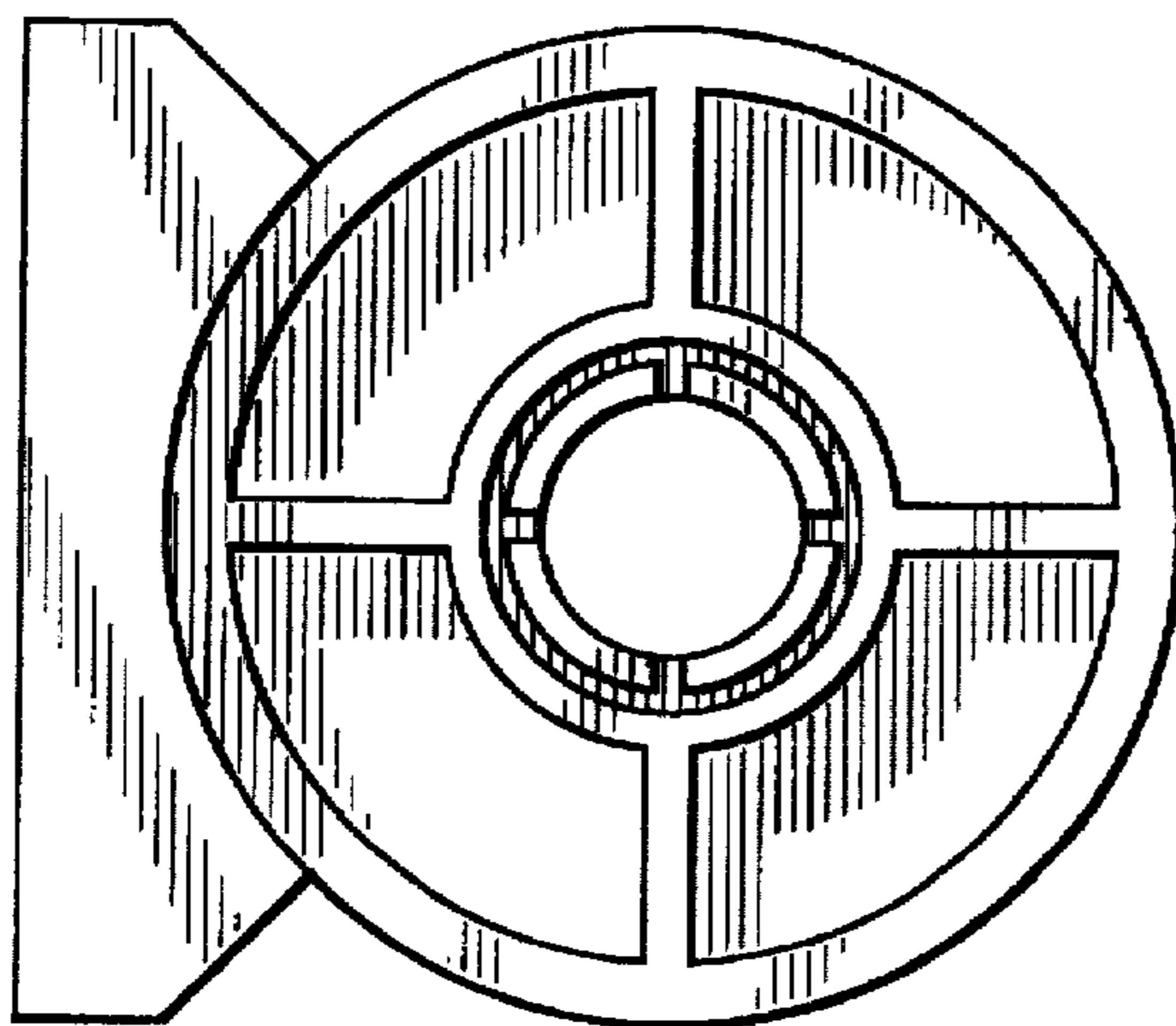

FIG. 7

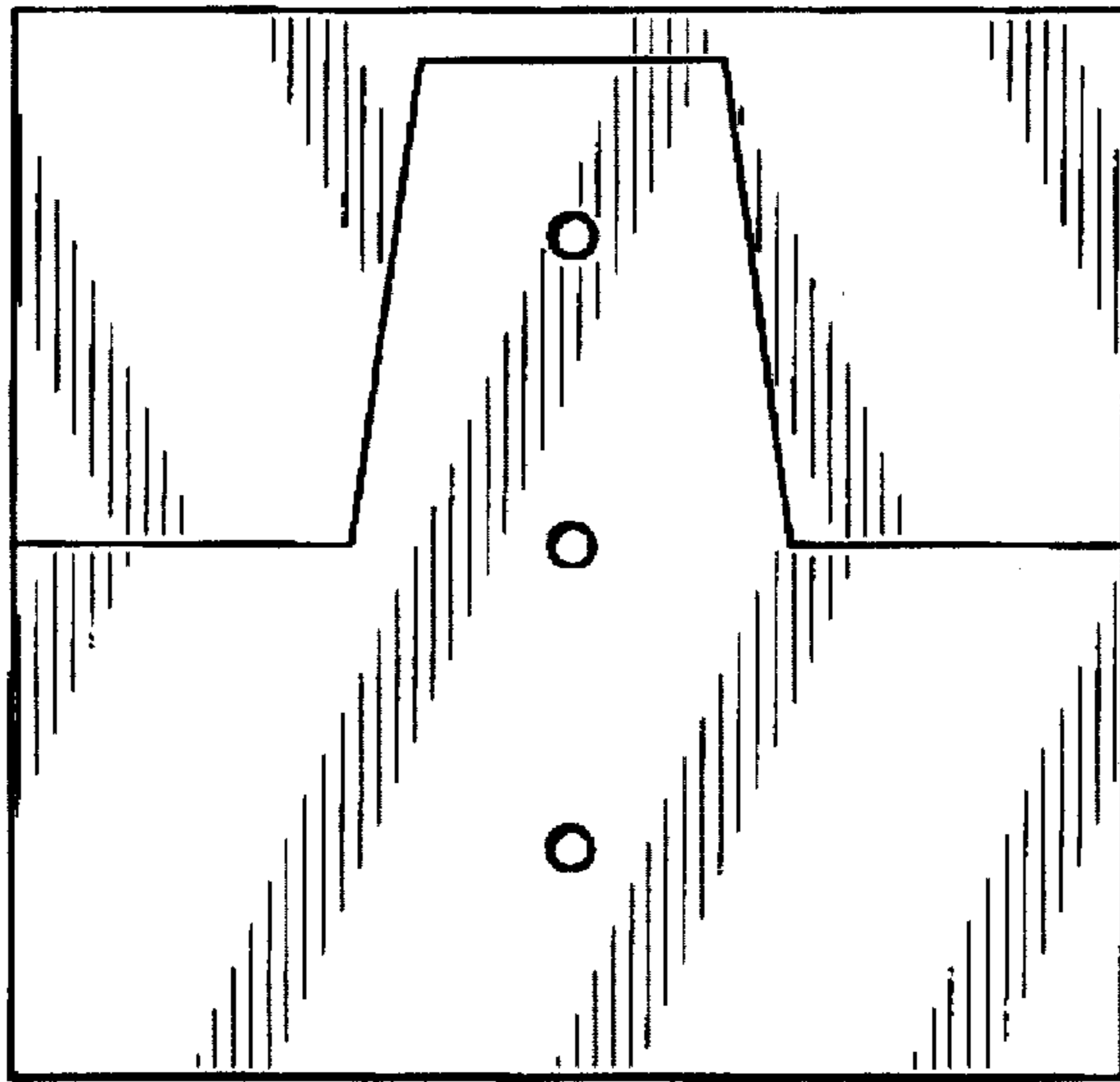

FIG. 8

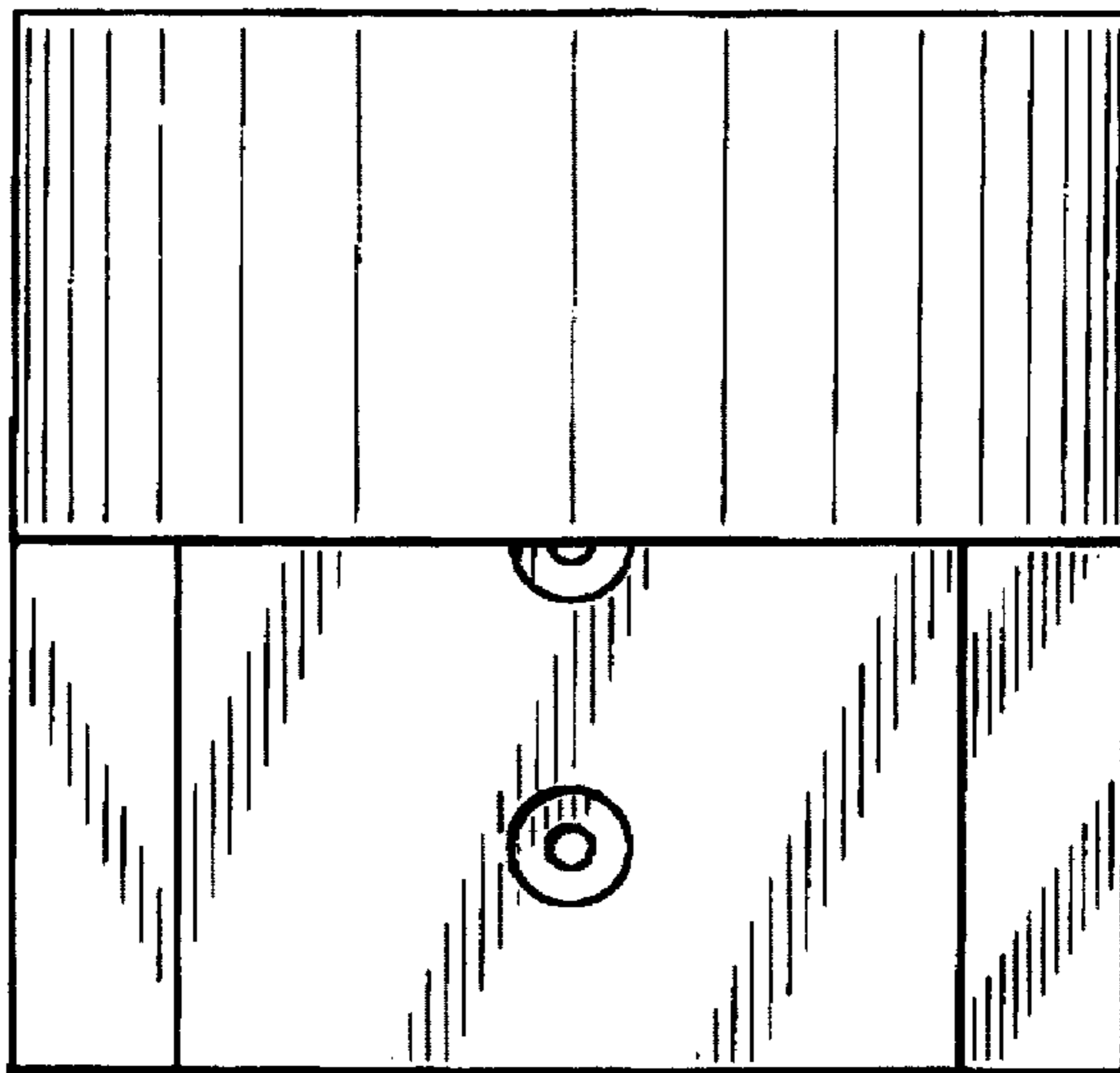

FIG. 9