



US00D387123S

United States Patent [19]

[11] Patent Number: Des. 387,123

Hughes et al.

[45] Date of Patent: **Dec. 2, 1997

[54] GUN SUPPORT

[75] Inventors: **Jeffrey T. Hughes; Christopher R. Rogers; Gordon S. Severt**, all of Winston-Salem; **Brooks V. Brock; Jimmy R. Saintsing**, both of Thomasville, all of N.C.

| | | | | |
|-----------|---------|---------------|-------|------------|
| 4,558,532 | 12/1985 | Wright | | 42/94 |
| 4,621,563 | 11/1986 | Poiencot | . | |
| 4,790,096 | 12/1988 | Gibson et al. | . | |
| 4,819,359 | 4/1989 | Bassett | | 89/39.04 X |
| 4,841,839 | 6/1989 | Stuart | . | |
| 5,058,302 | 10/1991 | Minneman | . | |
| 5,070,636 | 12/1991 | Mueller | | 42/94 |

[73] Assignee: **Hughes Products Company, Inc.**, Thomasville, N.C.

OTHER PUBLICATIONS

Lohman Cat, "Sight Vises", p. 3, right of page, Nov. 1995.

[**] Term: 14 Years

Primary Examiner—Louis S. Zarfaz
Assistant Examiner—Monica A. Weingart

[21] Appl. No.: 54,063

[57] CLAIM

[22] Filed: May 6, 1996

The ornamental design for a gun support, as shown and described.

[51] LOC (6) Cl. 22-01

[52] U.S. Cl. D22/199; D22/199

[58] Field of Search D22/100, 108,
D22/199; D6/552; 42/94; 89/37.04; 211/64,
89

DESCRIPTION

FIG. 1 is a front elevational view of a gun support showing our new design;

FIG. 2 shows a rear elevational view of the gun support as shown in FIG. 1;

FIG. 3 demonstrates a right side elevational view of the gun support as shown in FIG. 1, the left side being a mirror image thereof;

FIG. 4 shows a bottom plan view of the gun support as shown in FIG. 1;

FIG. 5 demonstrates a top plan view thereof; and,

FIG. 6 shows a rear top right side perspective view thereof.

[56] References Cited

U.S. PATENT DOCUMENTS

| | | | | |
|------------|---------|----------------|-------|----------|
| D. 375,538 | 11/1996 | Minneman | | D22/108 |
| 2,692,069 | 10/1954 | Winters et al. | | 211/64 X |
| 3,012,350 | 12/1961 | Wold | . | |
| 3,935,657 | 2/1976 | Wade | . | |
| 4,449,314 | 5/1984 | Sorenson | . | |
| 4,535,559 | 8/1985 | Hall | | 42/94 |
| 4,548,392 | 10/1985 | Rickling | . | |
| 4,558,531 | 12/1985 | Kilby | | 42/94 |

1 Claim, 4 Drawing Sheets

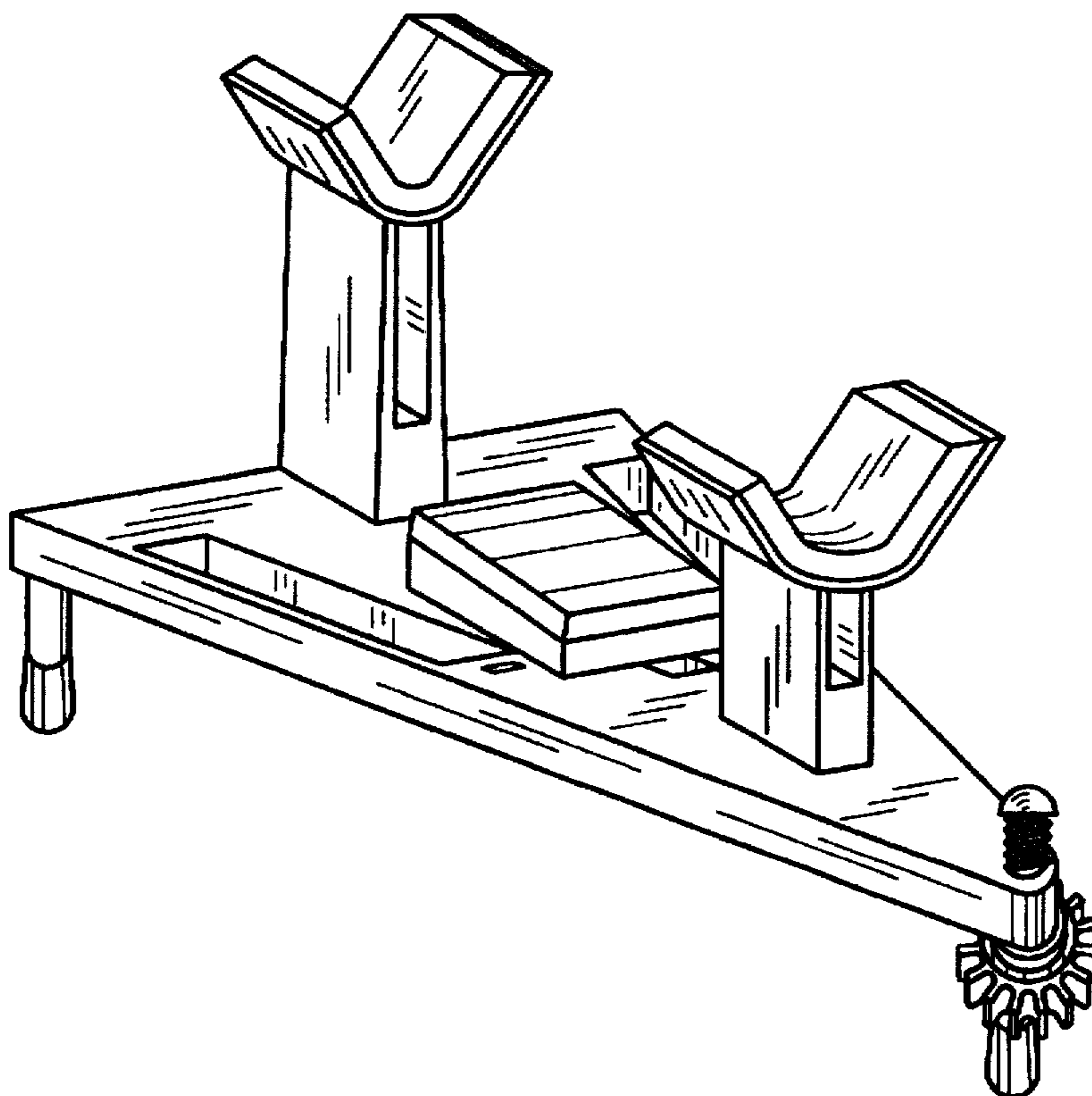

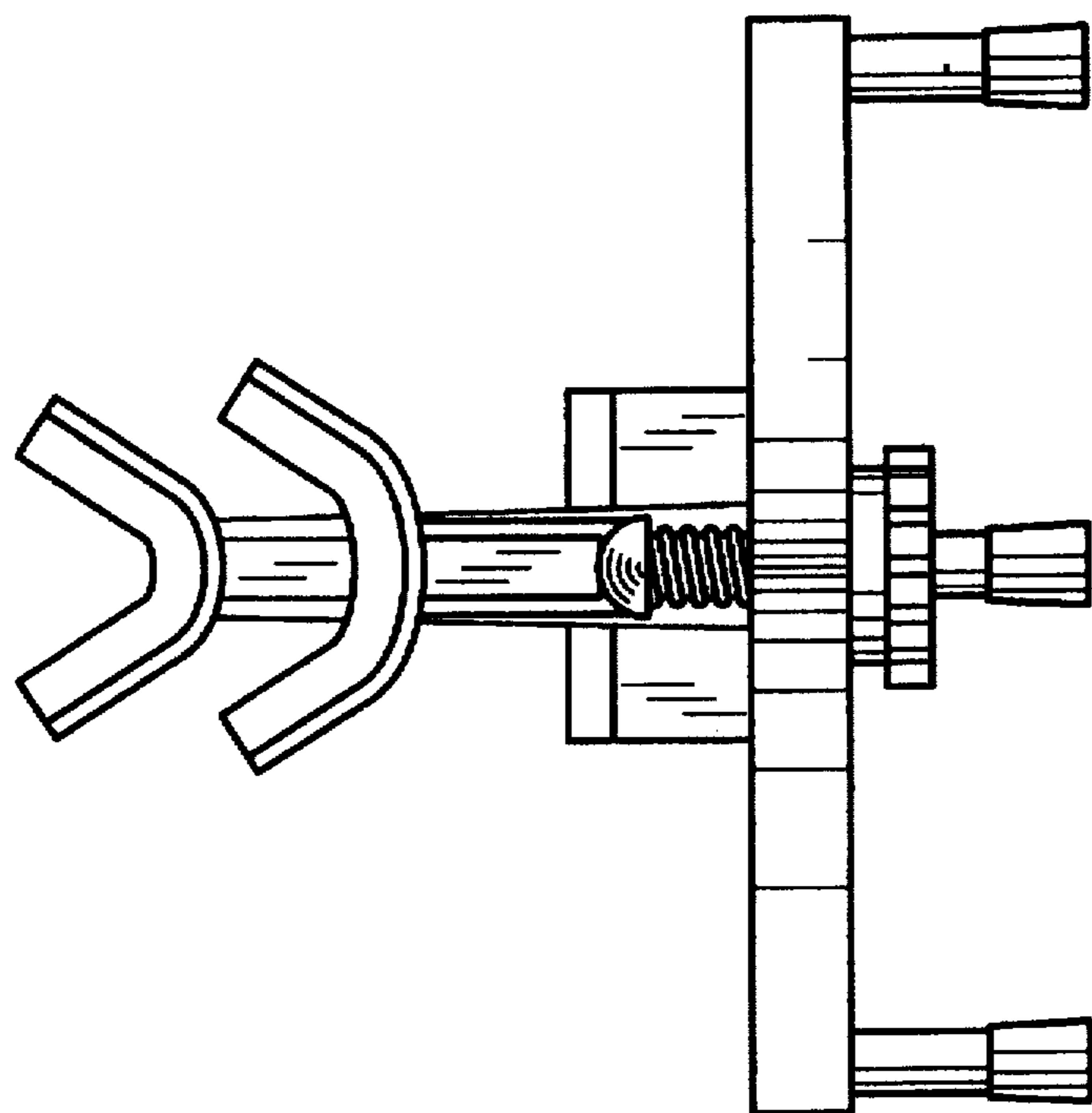

FIG. 2

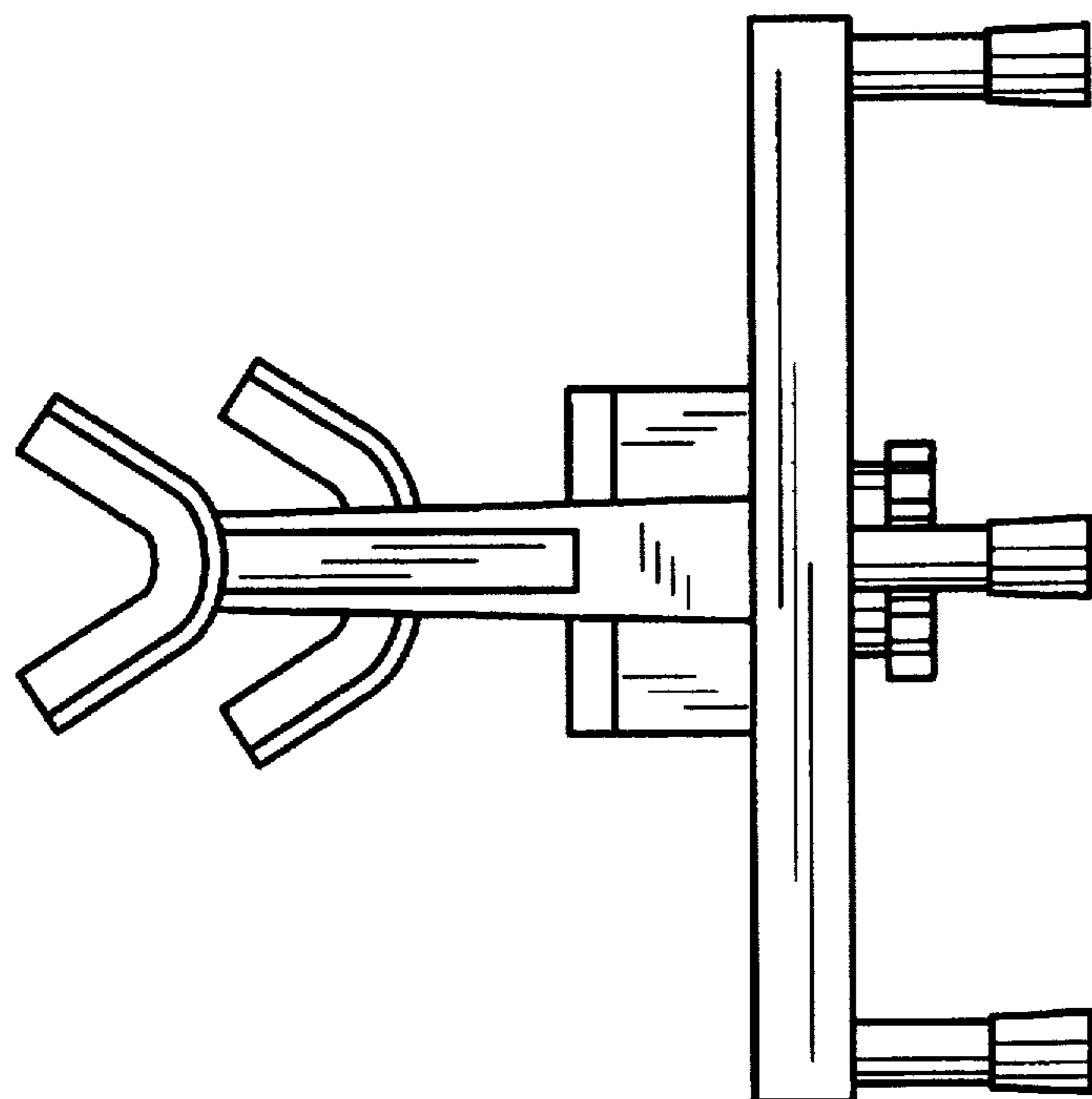

FIG. 1

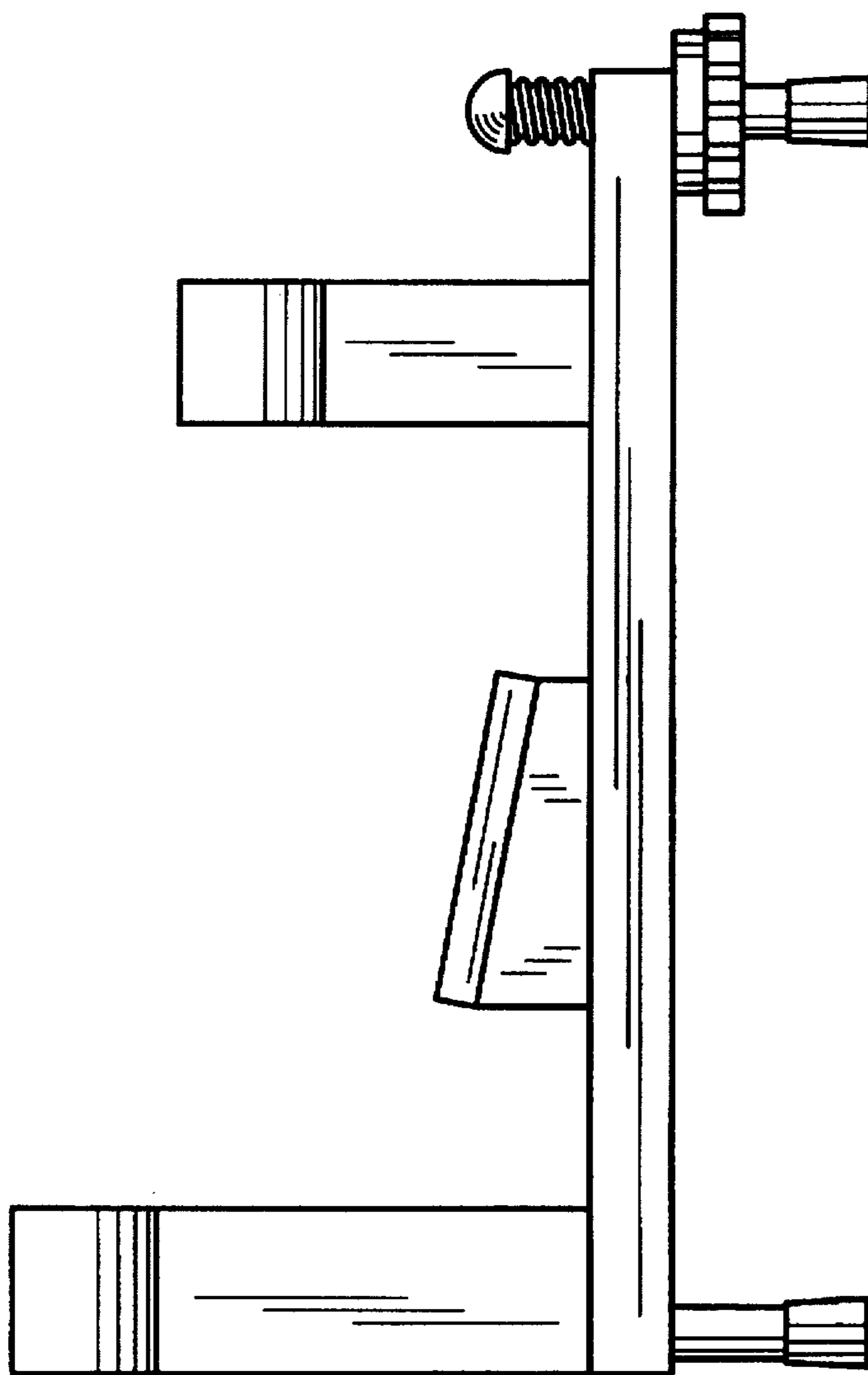

FIG. 3

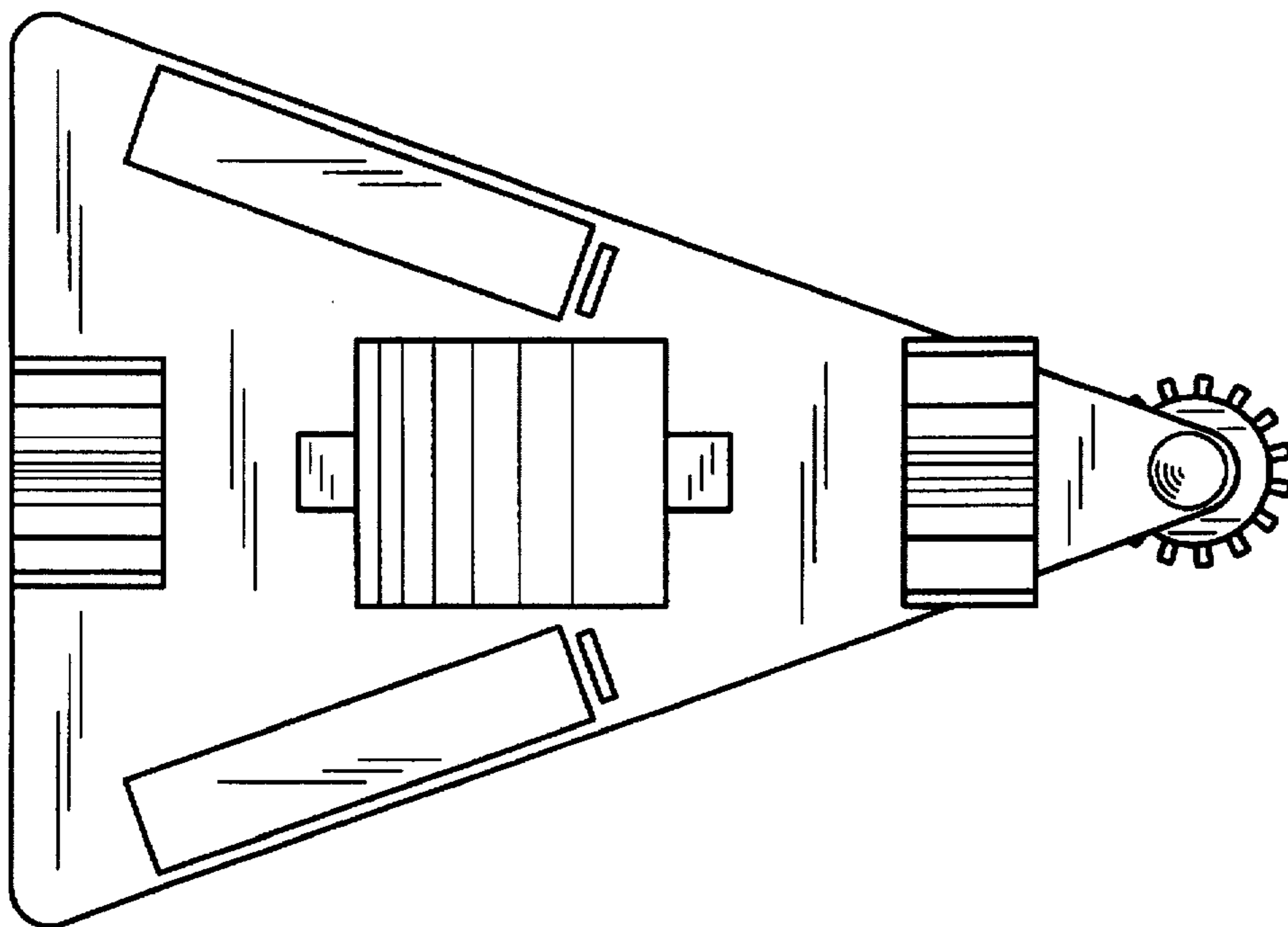

FIG. 5

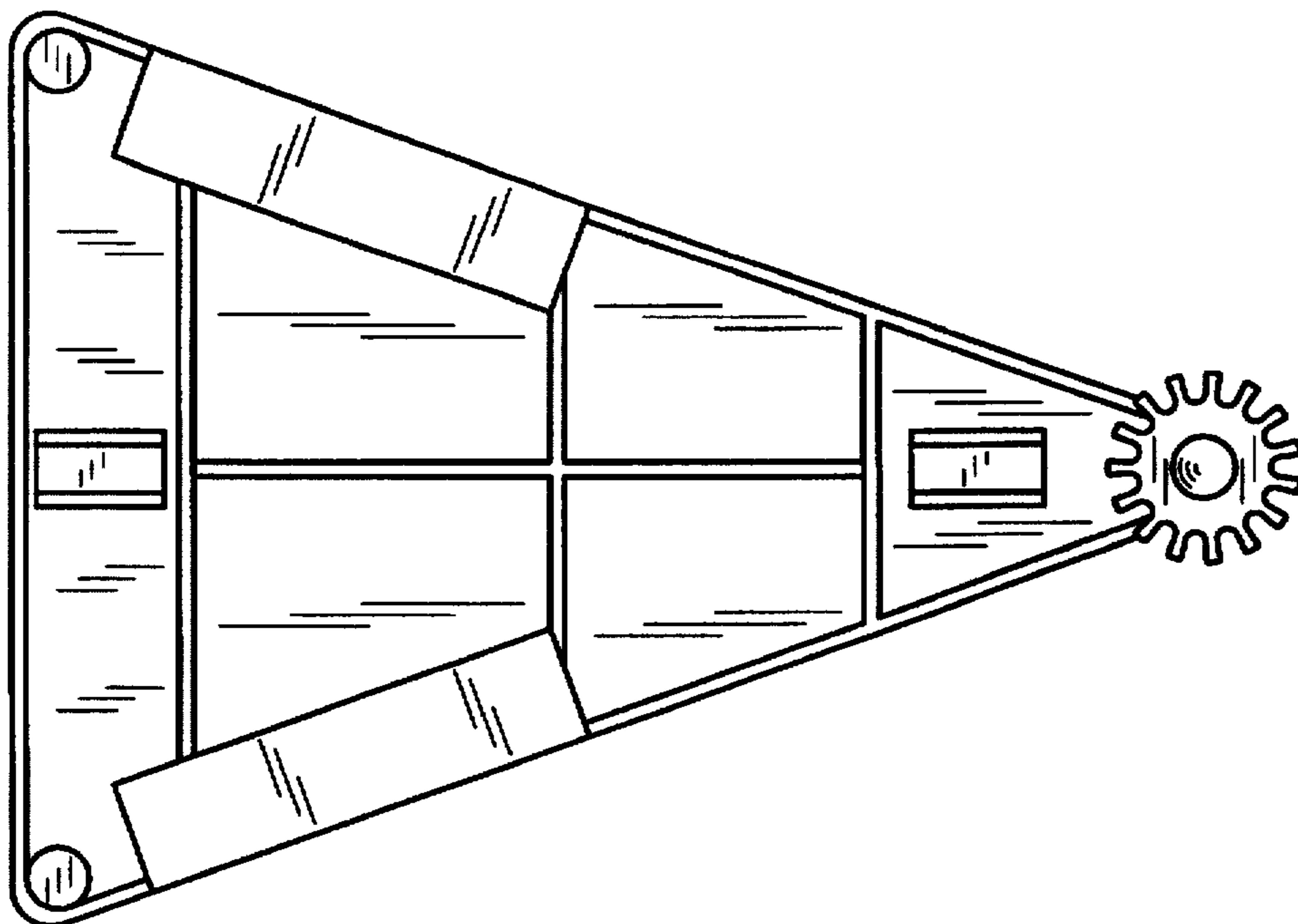

FIG. 4

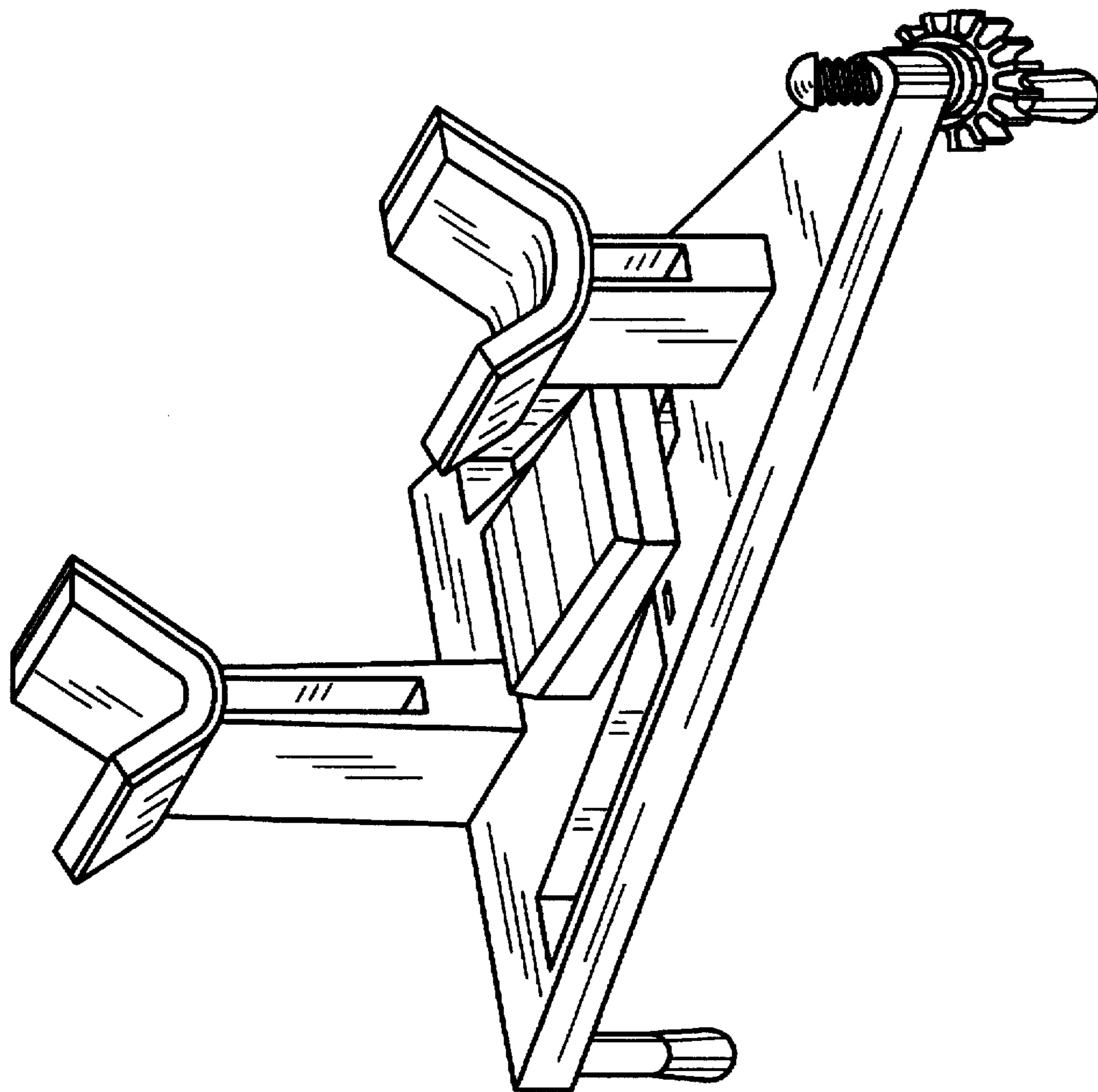

FIG. 6