



US00D387075S

**United States Patent** [19]  
**Farley**

[11] **Patent Number:** **Des. 387,075**  
[45] **Date of Patent:** **\*\*Dec. 2, 1997**

- [54] **HEATED PLATEN FOR LIQUIFYING THERMOPLASTIC MATERIALS**
- [75] Inventor: **Mark H. Farley, Roswell, Ga.**
- [73] Assignee: **Nordson Corporation, Westlake, Ohio**
- [\*\*] Term: **14 Years**
- [21] Appl. No.: **60,508**
- [22] Filed: **Sep. 30, 1996**
- [51] LOC (6) CL ..... **15-99**
- [52] U.S. Cl. .... **D15/144.2**
- [58] Field of Search ..... **D15/144.2; 249/79, 249/81, 141; 425/384, 407, 445, 817 R**

Nordson® Series 5000 Drum Melter Options (Publication, Issued Feb. 1992), Nordson Corp.  
 Meltex® Drum Unloader DP 201, Meltex Corp. (published on or before 1989).  
 UNIflow® Platen Options.  
 Meltex® Hydraulic Drum Melter DG 201 H, Meltex Corp. (published on or before 1989).  
 Nordson® Bulk Melter Systems, Issued Sep. 1990, Nordson Corp.

*Primary Examiner*—Antoine Duval Davis  
*Attorney, Agent, or Firm*—Raymond J. Slattery, III

[57] **CLAIM**

The ornamental design for a heated platen for liquifying thermoplastic materials, as shown and described.

**DESCRIPTION**

FIG. 1 is a perspective view of a new design for a heated platen, inverted from its normal orientation during operation;  
 FIG. 2 is a top plan view, rotated approximately 90° to the left according to the heated platen of FIG. 1;  
 FIG. 3 is a bottom plan view, of the heated platen of FIG. 2;  
 FIG. 4 is a side elevational view of the heated platen of FIG. 2, wherein all sides are substantially the same; and,  
 FIG. 5 is a cross-sectional view, taken along line 5—5 of FIG. 3.

[56] **References Cited**

**U.S. PATENT DOCUMENTS**

D. 341,146	11/1993	Stankosky	.....	D15/144.2
2,478,893	8/1949	Brant	.	
2,630,248	3/1953	Hinz	.	
3,282,469	11/1966	Skonberg	.	
3,637,111	1/1972	McCreary	.	
3,976,229	8/1976	Jackson	.	
3,982,669	9/1976	Moore	.	
4,090,640	5/1978	Smith et al.	.	
4,195,755	4/1980	Slautterback et al.	.	
4,227,069	10/1980	Gardner et al.	.	
5,173,308	12/1992	Scantland et al.	.....	249/79 X

**OTHER PUBLICATIONS**

Meltex® Drum Melter DG 21, Meltex Corp. (published on or before 1989).  
 Meltex® Information Drum Melters, Meltex Corp. (published on or before 1989).

**1 Claim, 3 Drawing Sheets**

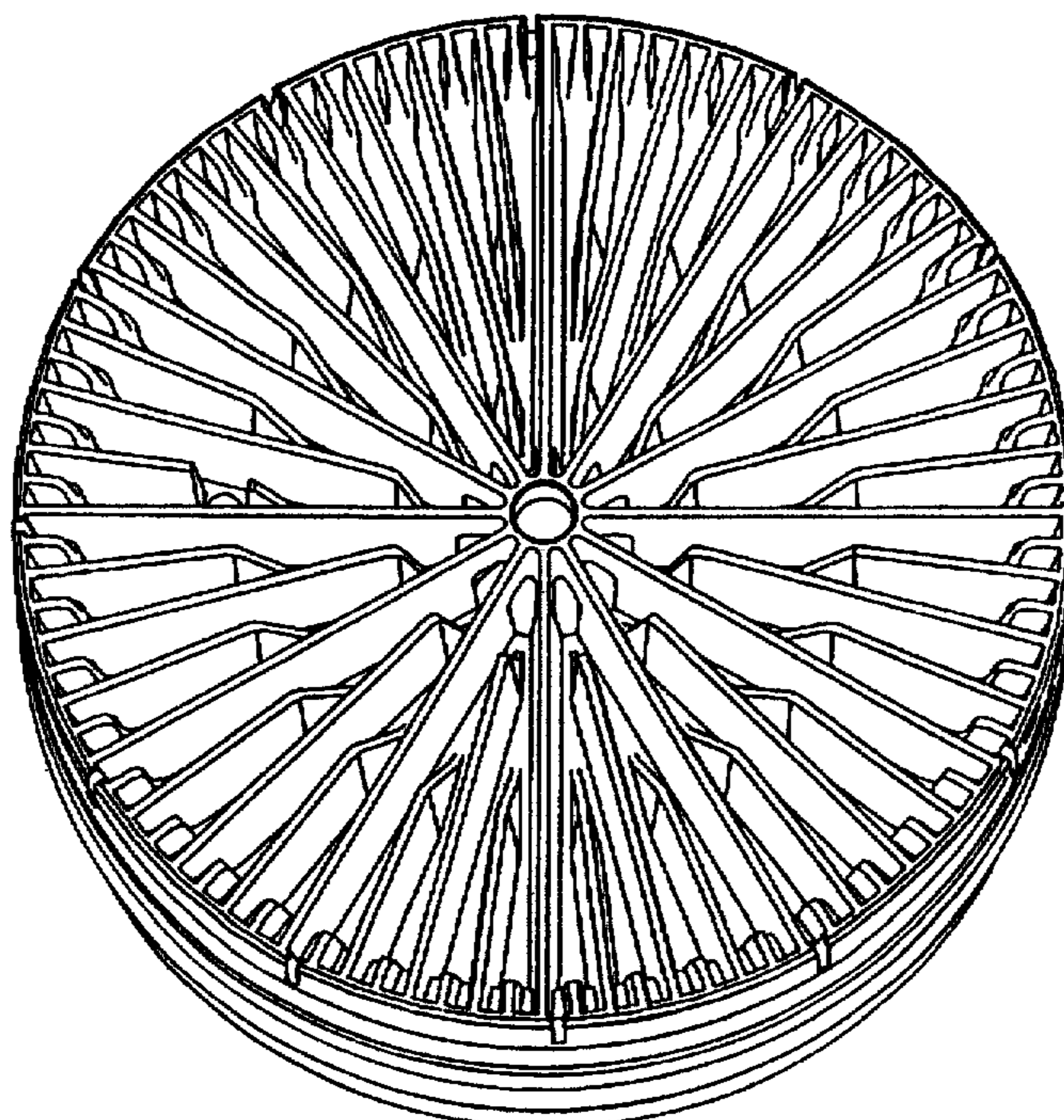

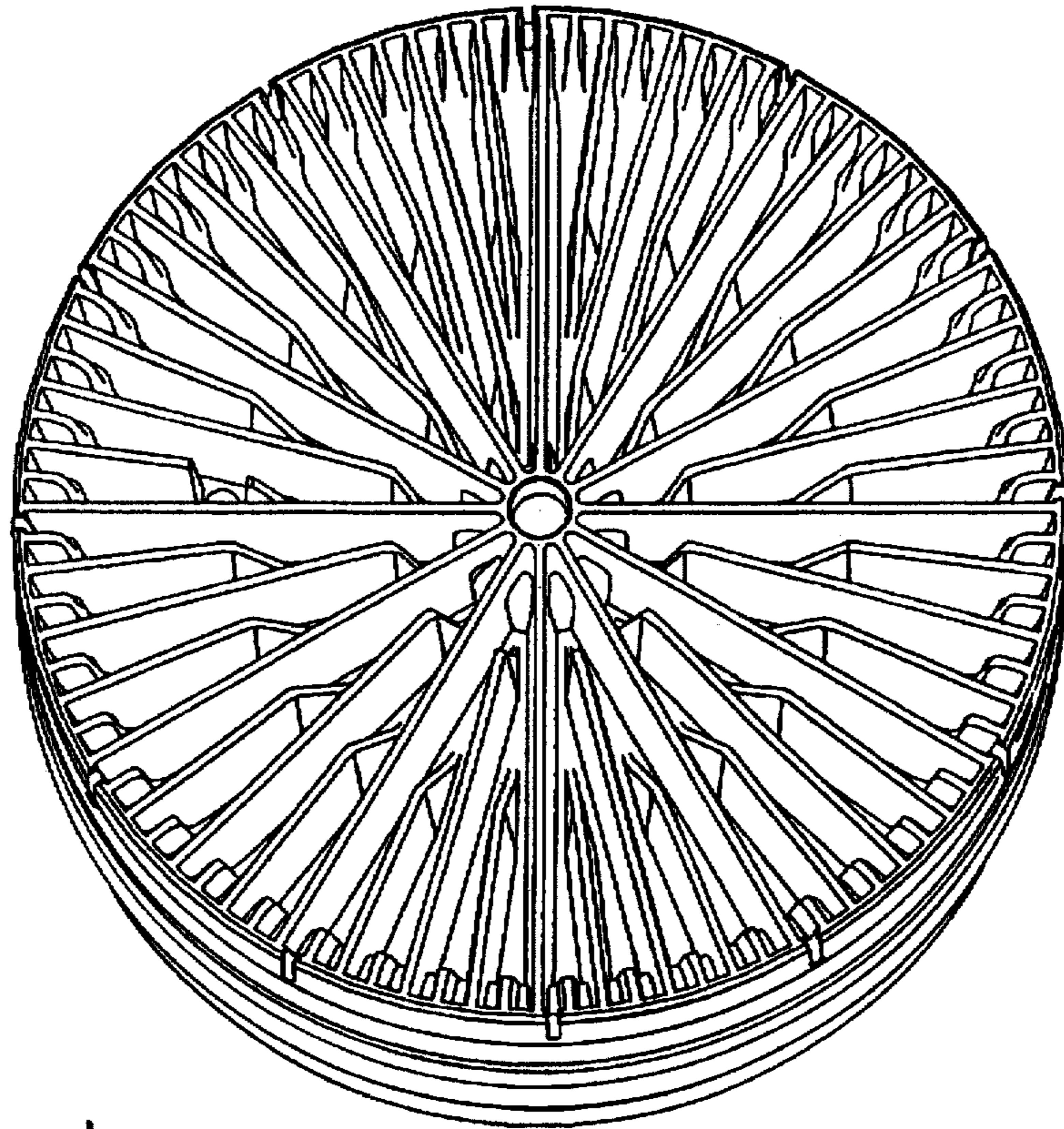

FIG.-1

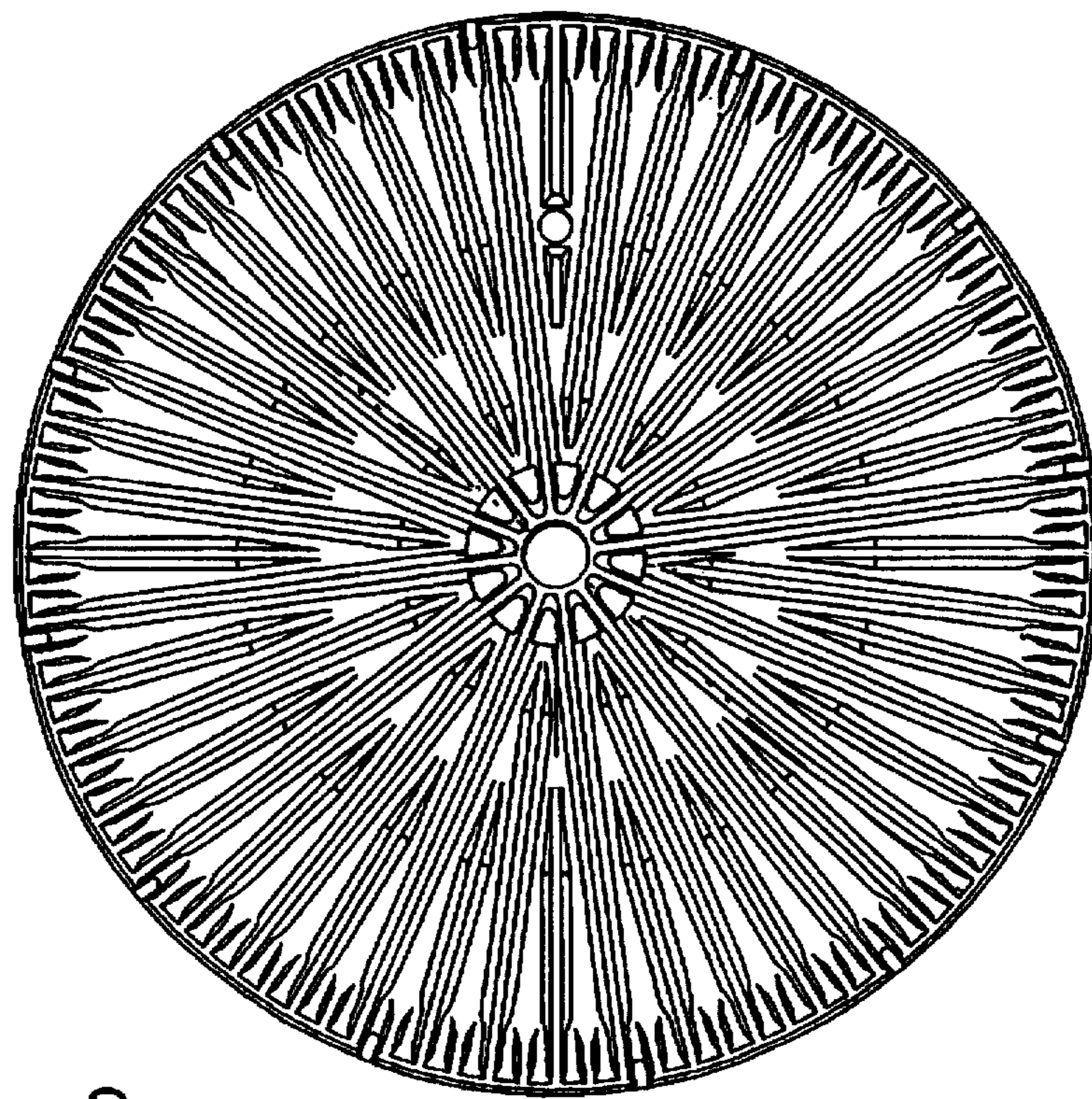

FIG.-2

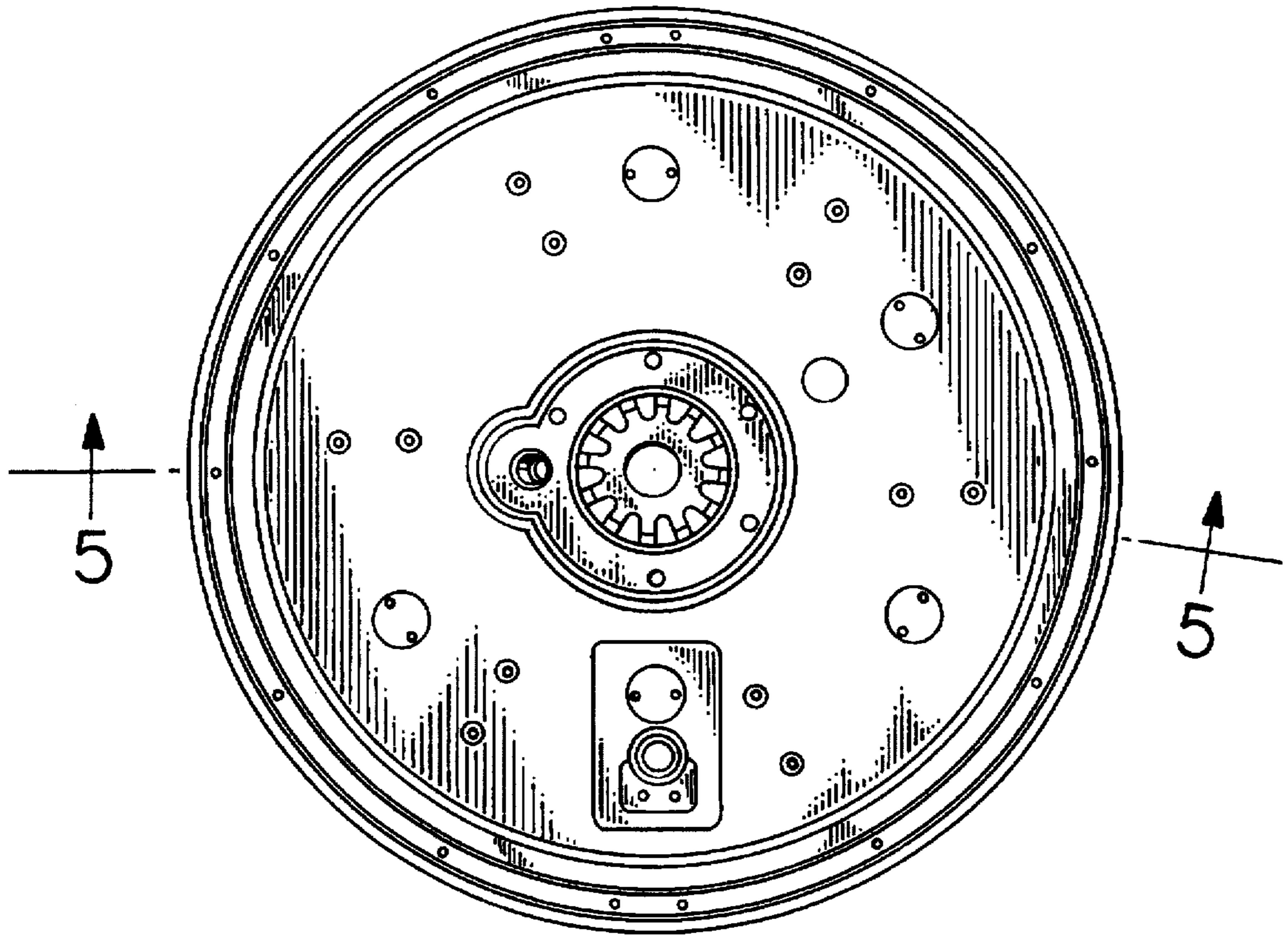

FIG.-3

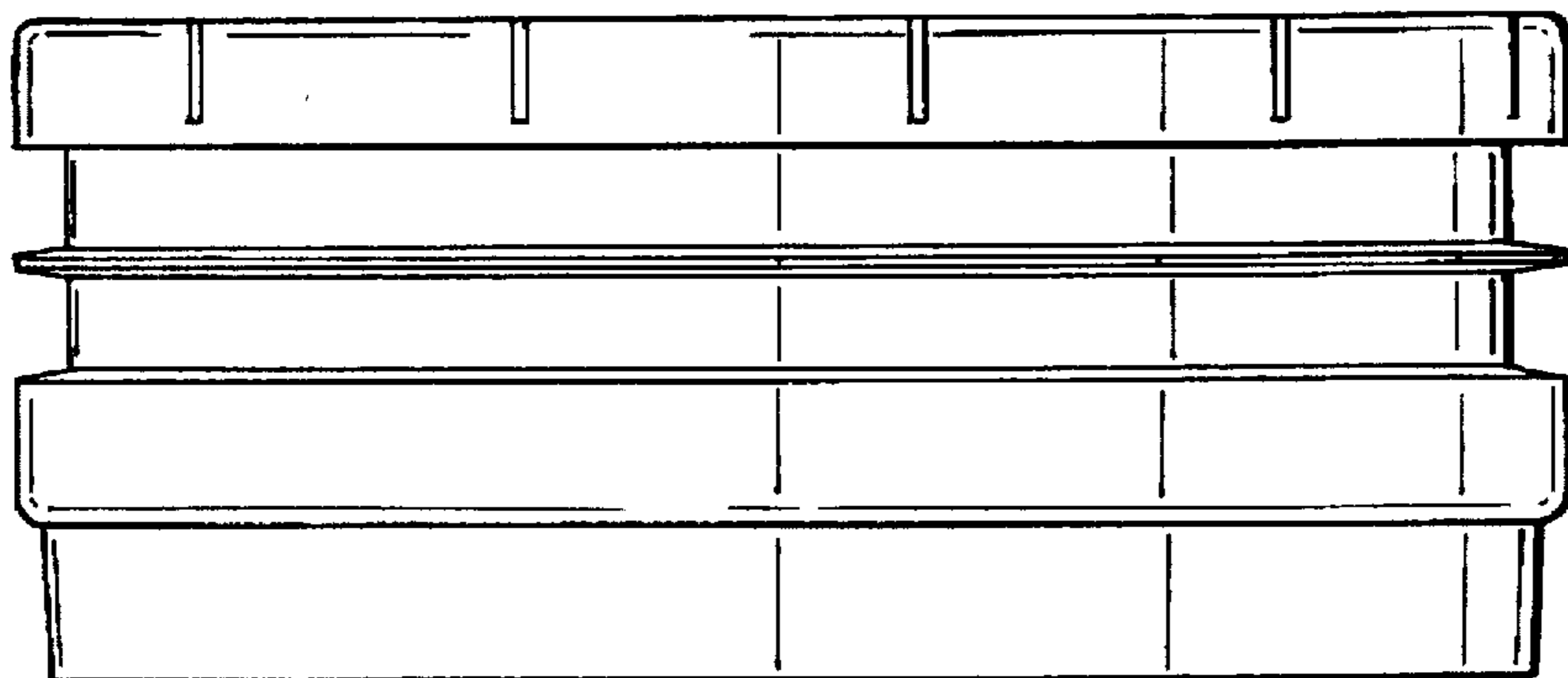

FIG.-4

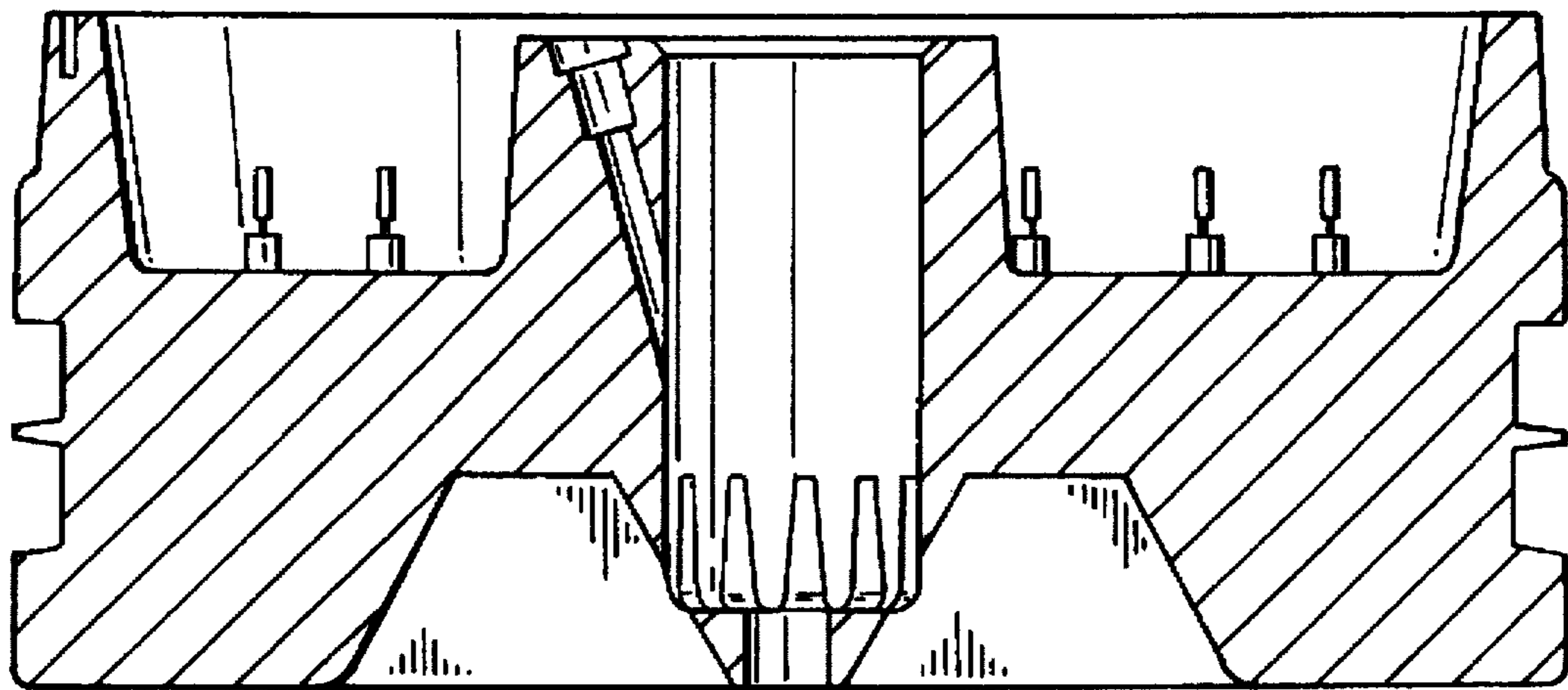

FIG.-5