



US00D386744S

United States Patent [19]
Urvoy

[11] **Patent Number: Des. 386,744**
[45] **Date of Patent: **Nov. 25, 1997**

[54] **MOTOR**
[75] **Inventor: Jean-Jacques Urvoy, Paris, France**
[73] **Assignee: Meccano, S.A., Calais, France**
[**] **Term: 14 Years**

D. 140,211 1/1945 Lear D13/112
D. 310,816 9/1990 Sawato et al. D13/112
3,361,917 1/1968 Stahly 310/47 X
4,988,905 1/1991 Tolmie, Jr. 310/89 X
5,357,161 10/1994 Daniels 310/89

Primary Examiner—Holly Baynham
Attorney, Agent, or Firm—Pennie & Edmonds LLP

[21] **Appl. No.: 51,000**
[22] **Filed: Mar. 1, 1996**

[57] **CLAIM**

The ornamental design for a motor, as shown and described.

[30] **Foreign Application Priority Data**

DESCRIPTION

Oct. 2, 1995 [WO] WIPO D12220
[51] **LOC (6) Cl. 13-02**
[52] **U.S. Cl. D13/112**
[58] **Field of Search D13/112; 310/47,**
310/50, 89; D15/1-4; 112/220

FIG. 1 is a perspective view of a motor according to the invention;
FIG. 2 is a top side view thereof;
FIG. 3 is a bottom side view thereof;
FIG. 4 is a front side view thereof;
FIG. 5 is a rear side view thereof;
FIG. 6 is a right side view thereof; and,
FIG. 7 is a left side view thereof.

[56] **References Cited**

U.S. PATENT DOCUMENTS

D. 133,058 7/1942 Drake D13/112

1 Claim, 2 Drawing Sheets

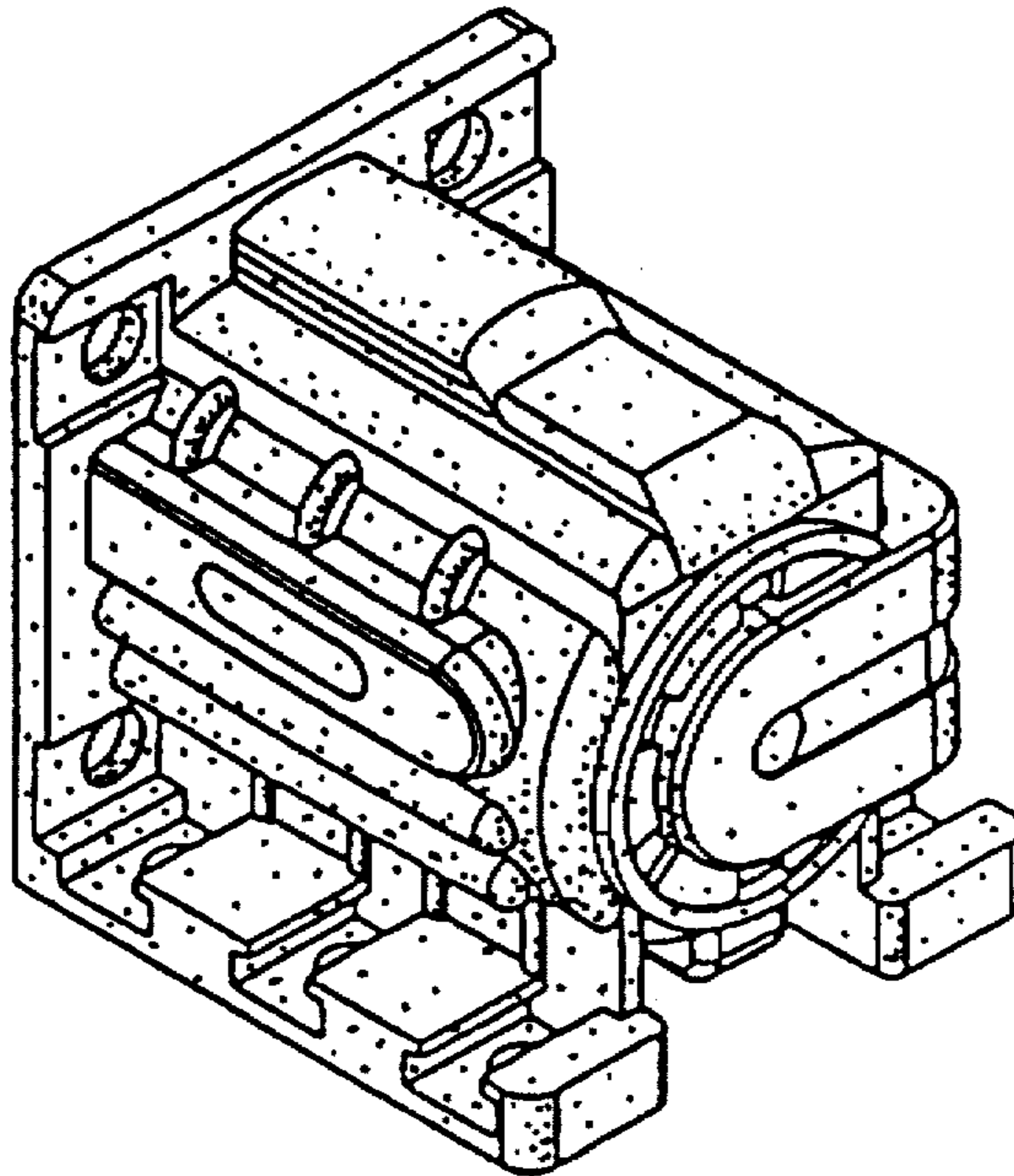

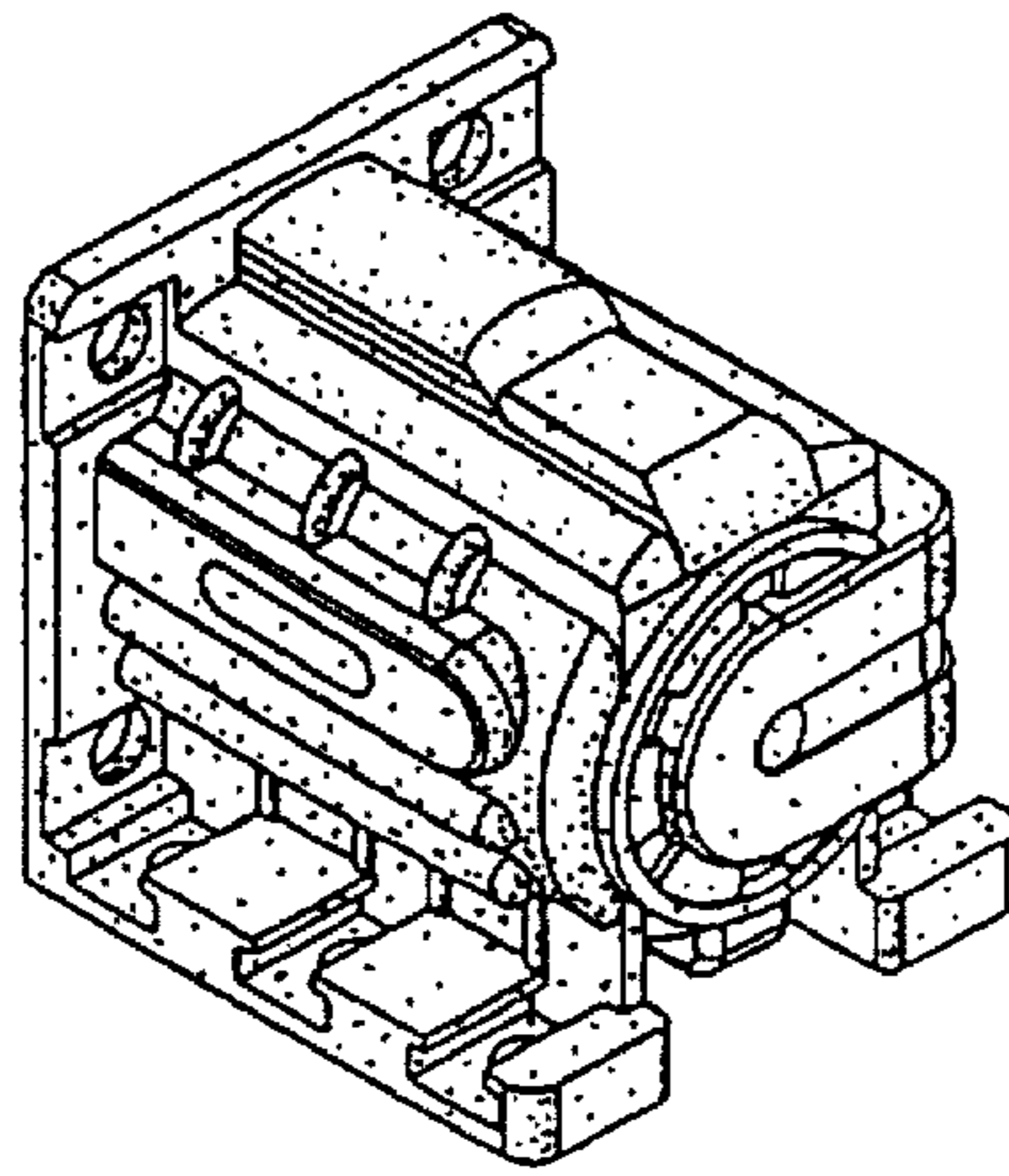

FIG. 1

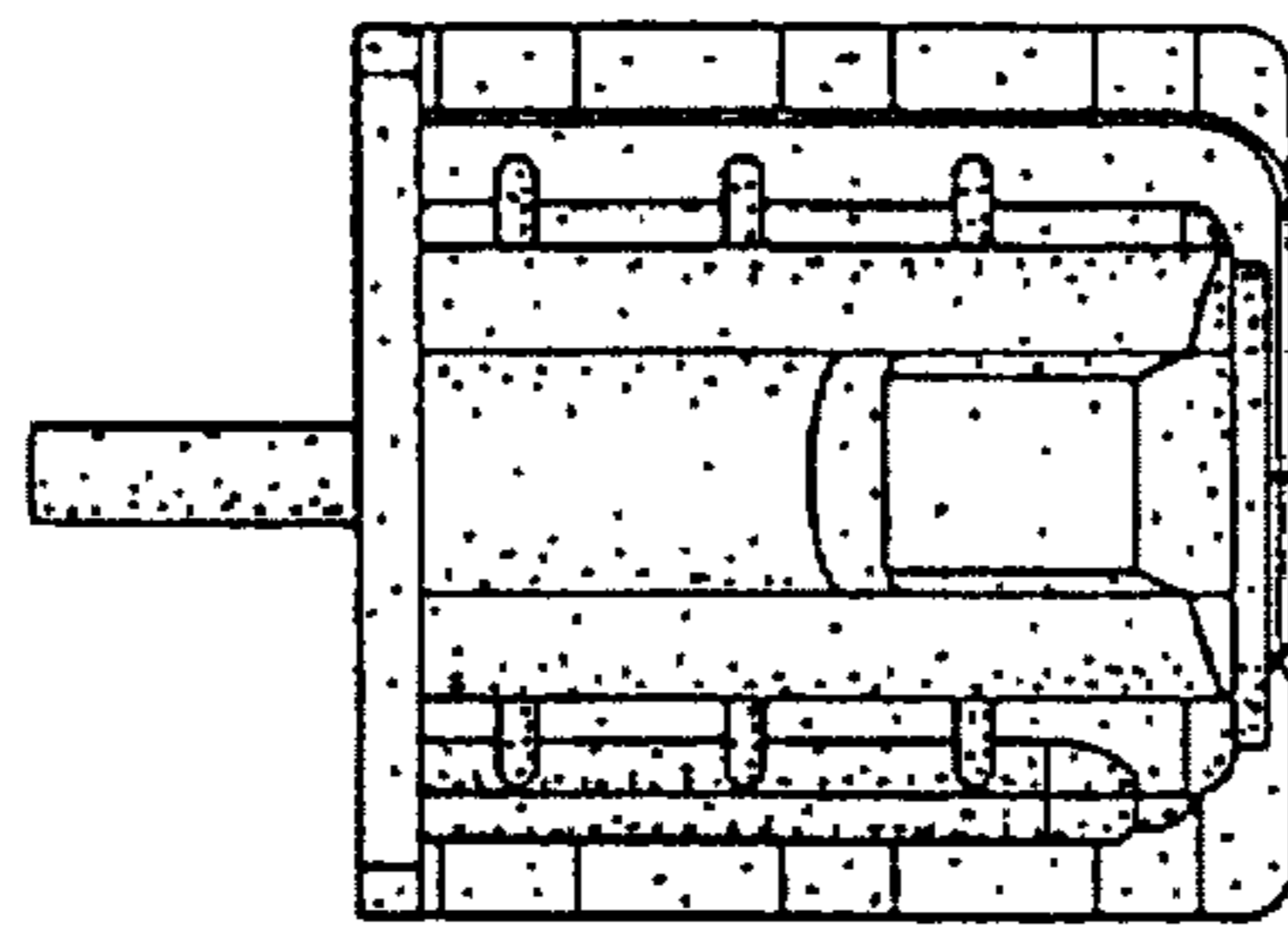

FIG. 2

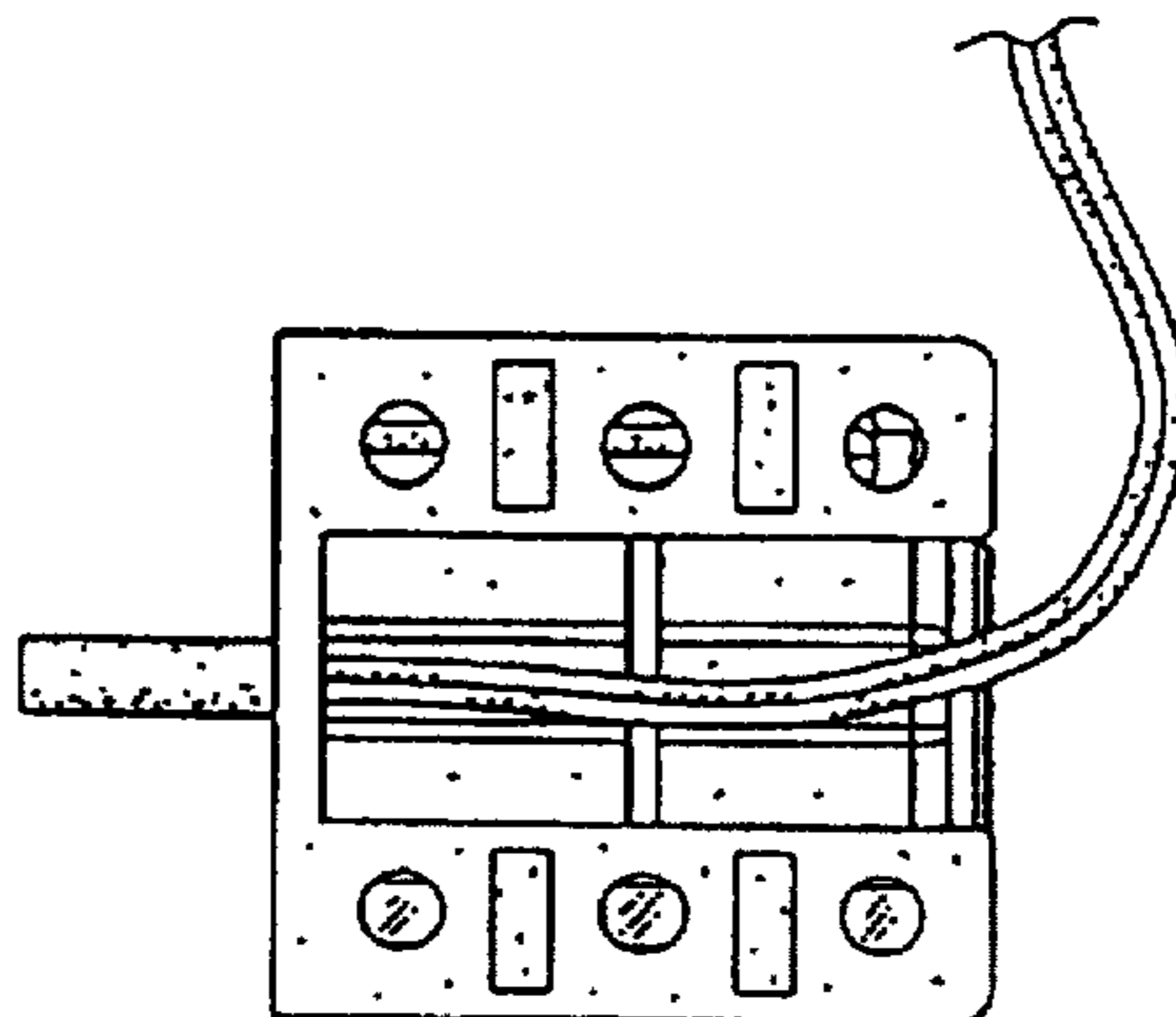

FIG. 3

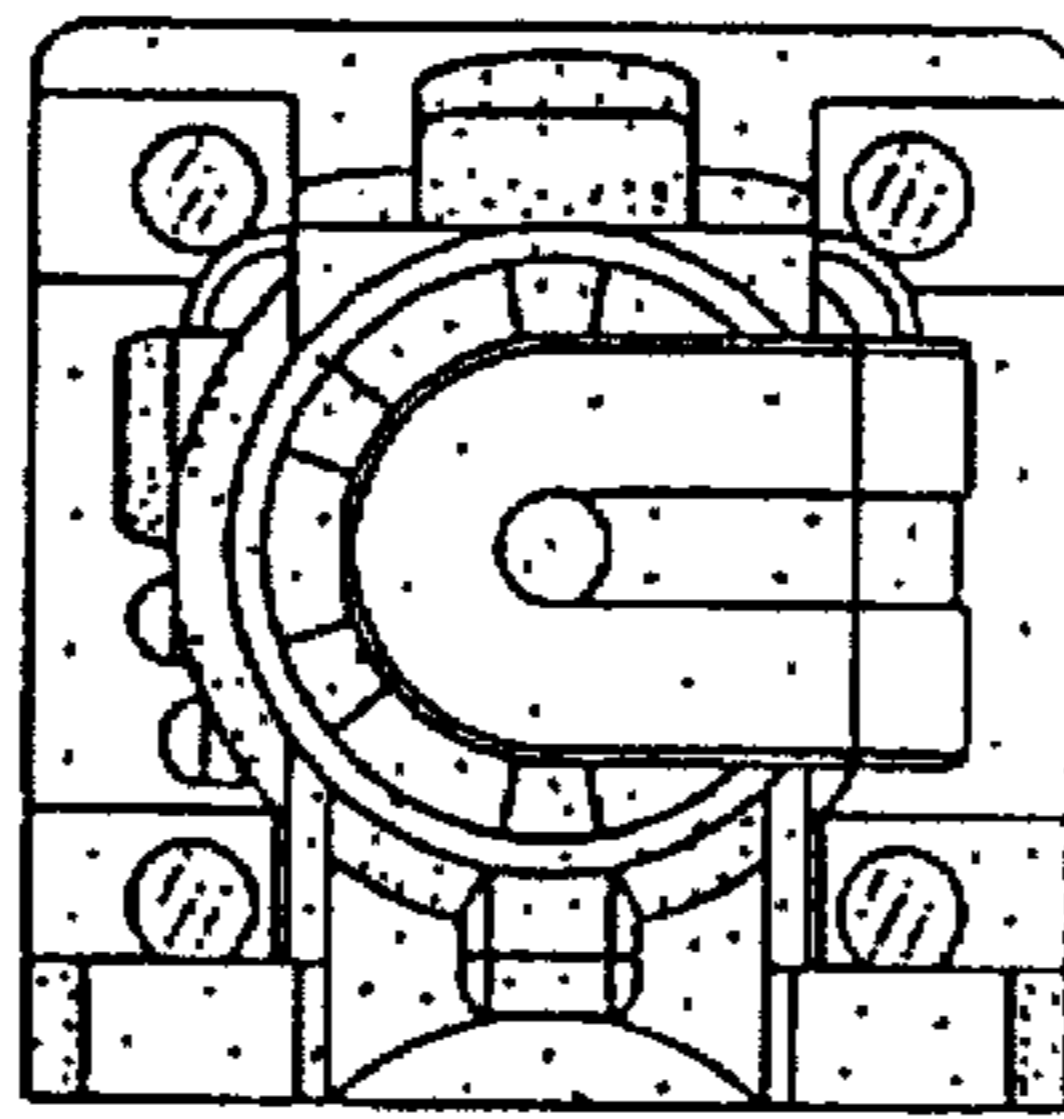

FIG. 4

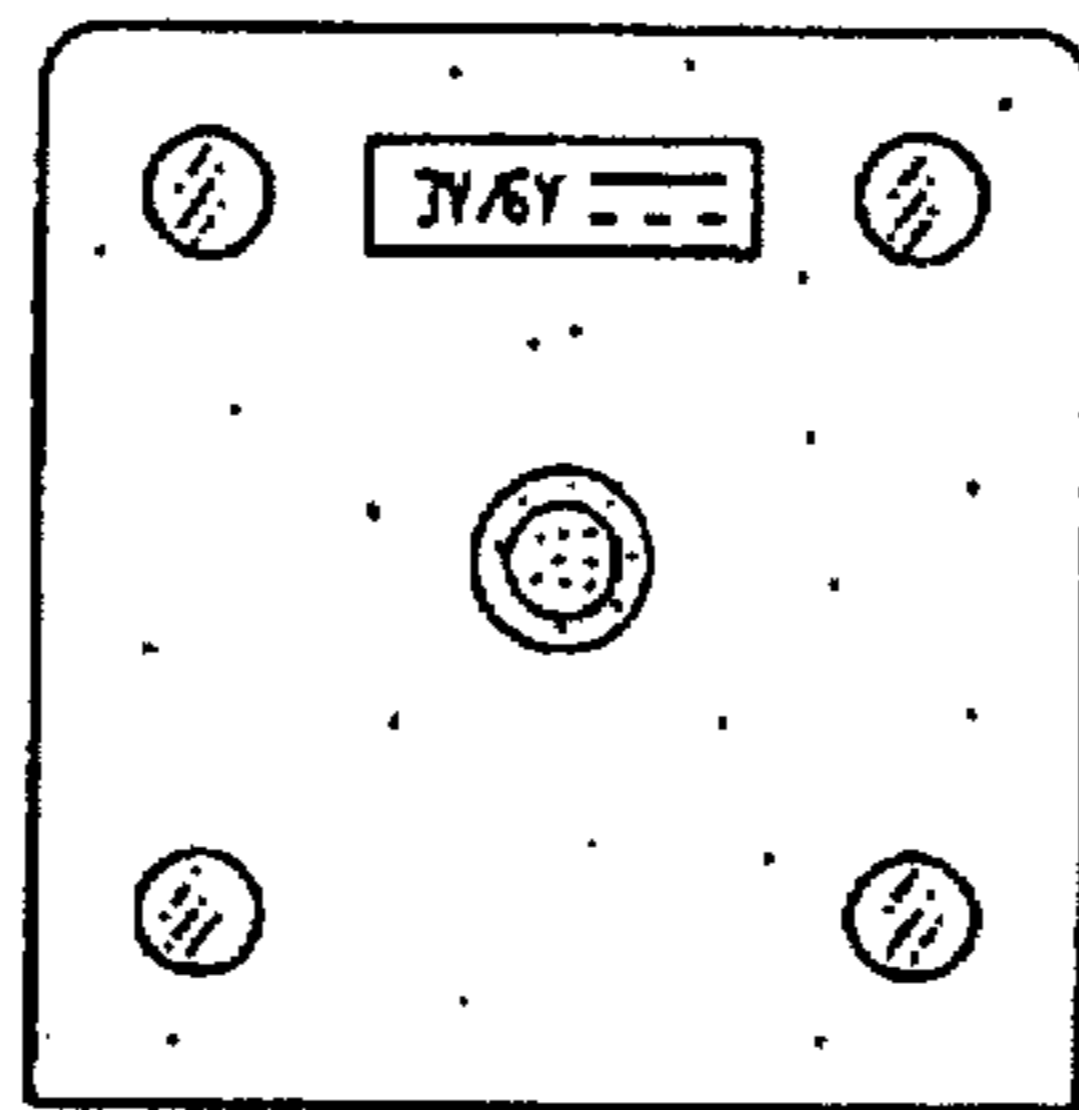

FIG. 5

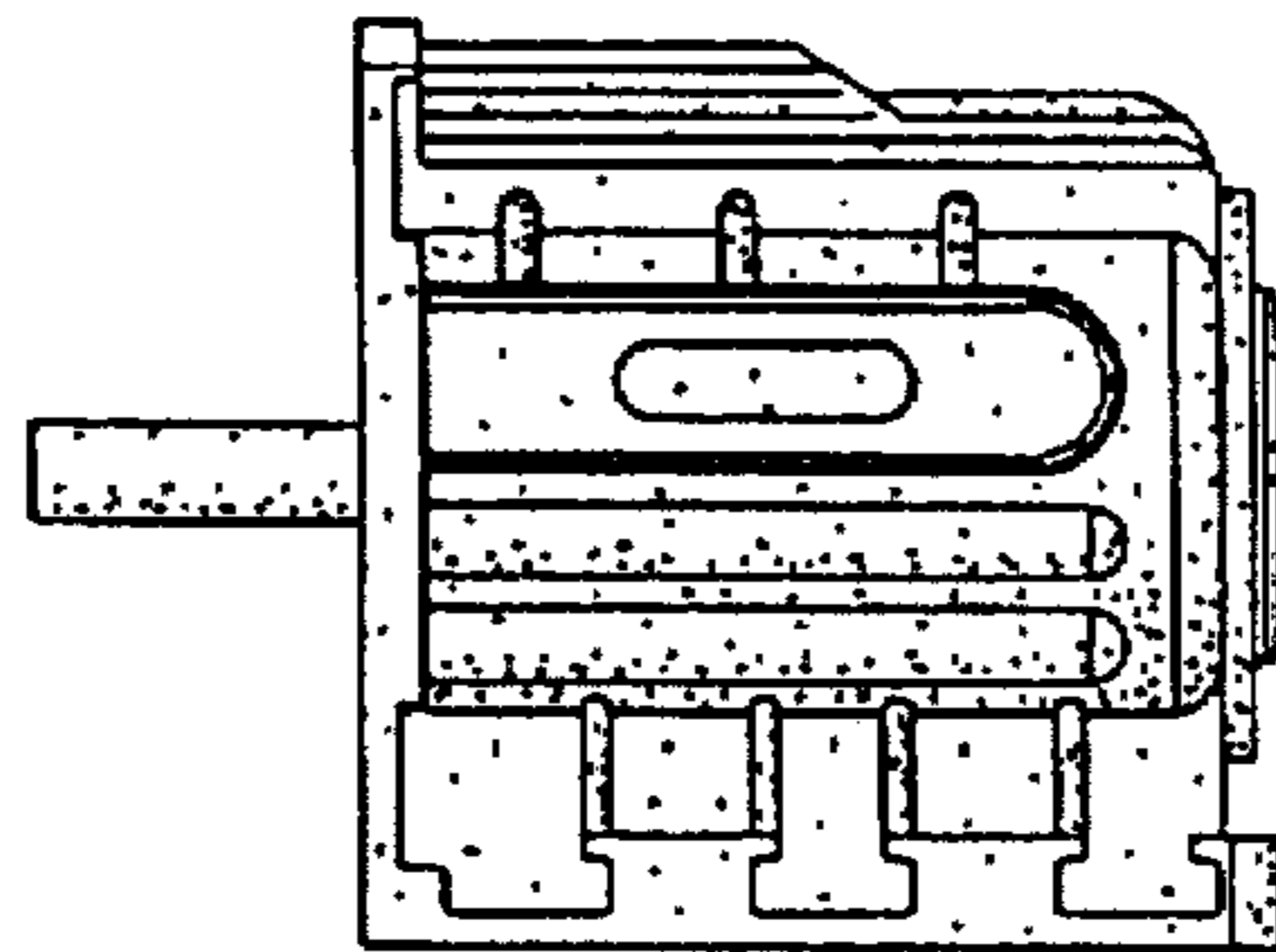

FIG. 6

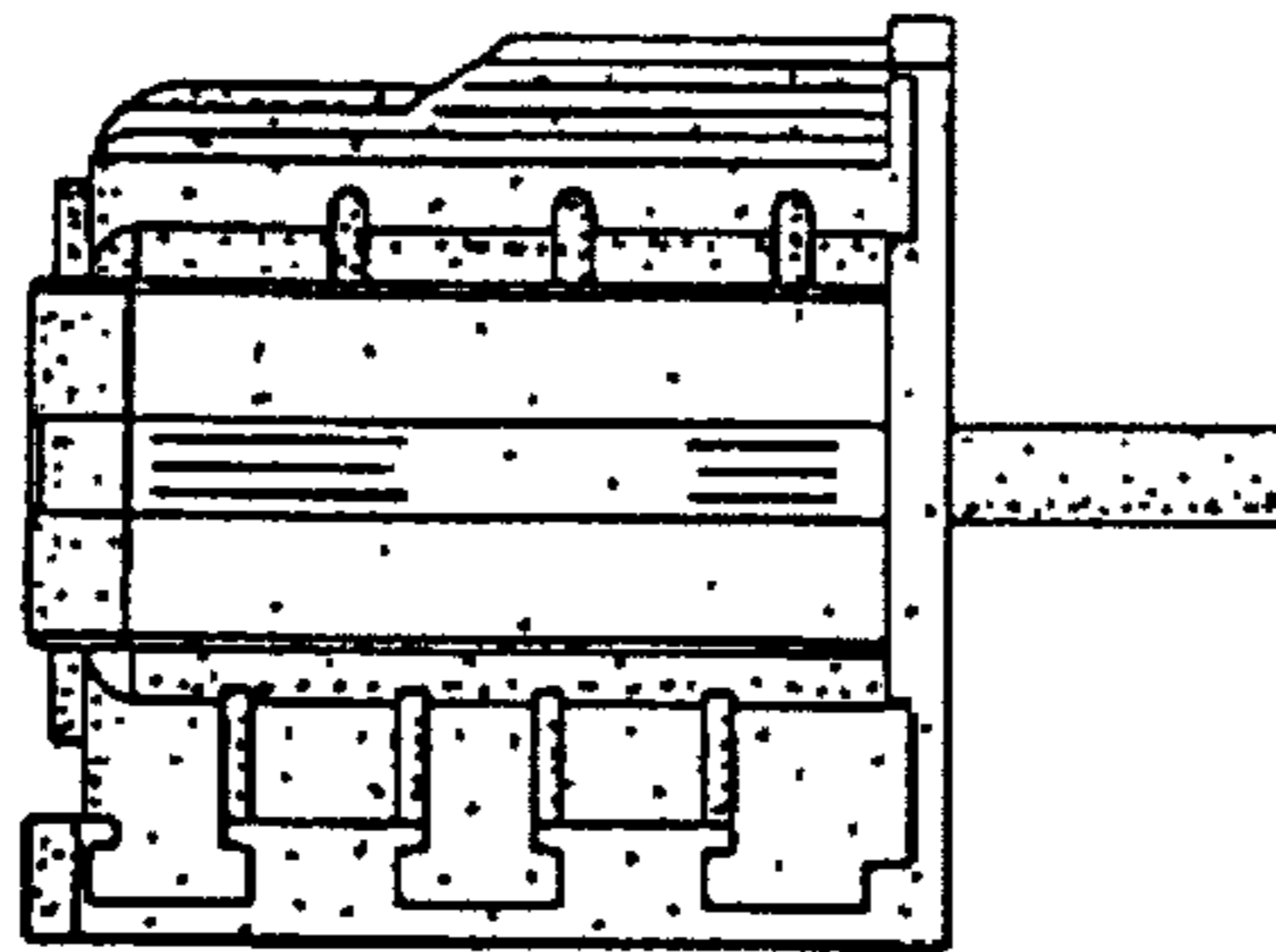

FIG. 7