



US00D386721S

United States Patent [19] Bedard

[11] Patent Number: Des. 386,721

[45] Date of Patent: ***Nov. 25, 1997

[54] SNOWMOBILE TRACK

[75] Inventor: Serge A. Bedard, Valcourt, Canada

[73] Assignee: Bombardier Inc., Montreal, Canada

[*] Notice: The portion of the term of this patent subsequent to Jul. 1, 2011, has been disclaimed.

[**] Term: 14 Years

[21] Appl. No.: 48,578

[22] Filed: Jan. 4, 1996

Related U.S. Application Data

[63] Continuation-in-part of Ser. No. 32,817, Dec. 29, 1994.

[51] LOC (6) Cl. 12-14

[52] U.S. Cl. D12/7

[58] Field of Search D12/7, 1; D15/28; D8/499; D34/29, 35; 305/39, 180

[56] References Cited

U.S. PATENT DOCUMENTS

D. 283,206	4/1986	Talbot	D12/7
3,790,231	2/1974	Rose	305/180
3,857,617	12/1974	Grawley	305/180
3,895,845	7/1975	Hale	305/180
4,351,380	9/1982	Pilliod, Jr. et al.	305/180 X
4,938,546	7/1990	Simmons	305/180

Primary Examiner—Doris V. Coles
Assistant Examiner—Catherine R. Oliver
Attorney, Agent, or Firm—Dorsey & Whitney LLP

[57] CLAIM

The ornamental design for a snowmobile track, as shown and described.

DESCRIPTION

FIG. 1 is a side elevational view of the snowmobile track showing my new design with the break lines being indicative of indeterminate length;

FIG. 2 is a plan view of the section of snowmobile track indicated by the arrows 2—2 in FIG. 1;

FIG. 3 is a perspective view of a section of the snowmobile track as seen from the left hand side and upper end of FIG. 2;

FIG. 4 is a cross-sectional view taken on the line 4—4 in FIG. 3 in the direction of the arrows;

FIG. 5 is a somewhat enlarged plan view of a section of the track, the bottom view being a mirror image thereof;

FIG. 6 is a sectional view taken on the line 6—6 in FIG. 5 in the direction of the arrows;

FIG. 7 is a view as seen in the direction of the arrows 7—7 in FIG. 5;

FIG. 8 is a view corresponding to FIG. 5 but showing a slightly modified form of track, the bottom view of which is a mirror image thereof; and,

FIG. 9 is a view as seen in the direction of the arrows 9—9 in FIG. 8.

1 Claim, 4 Drawing Sheets

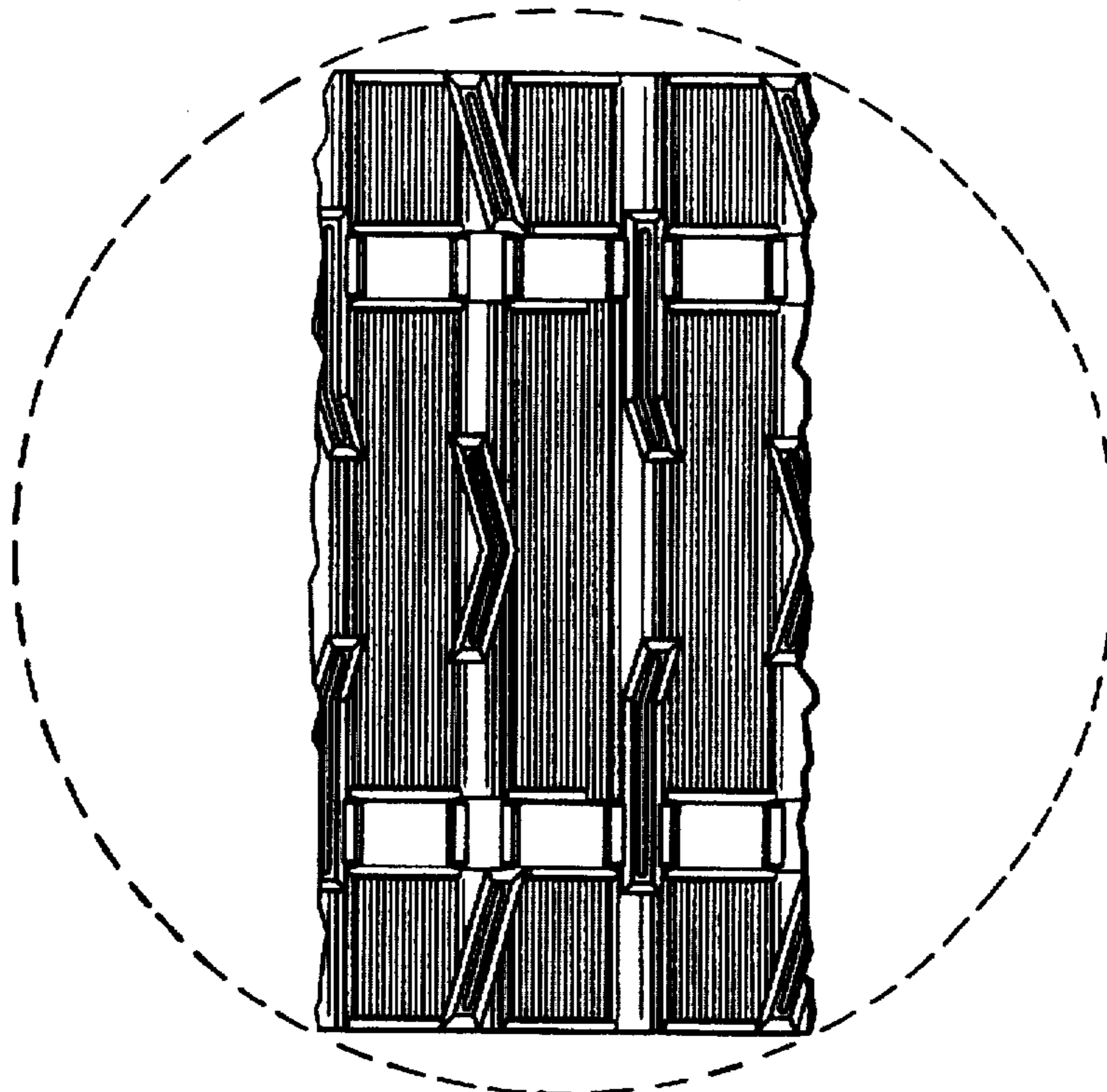

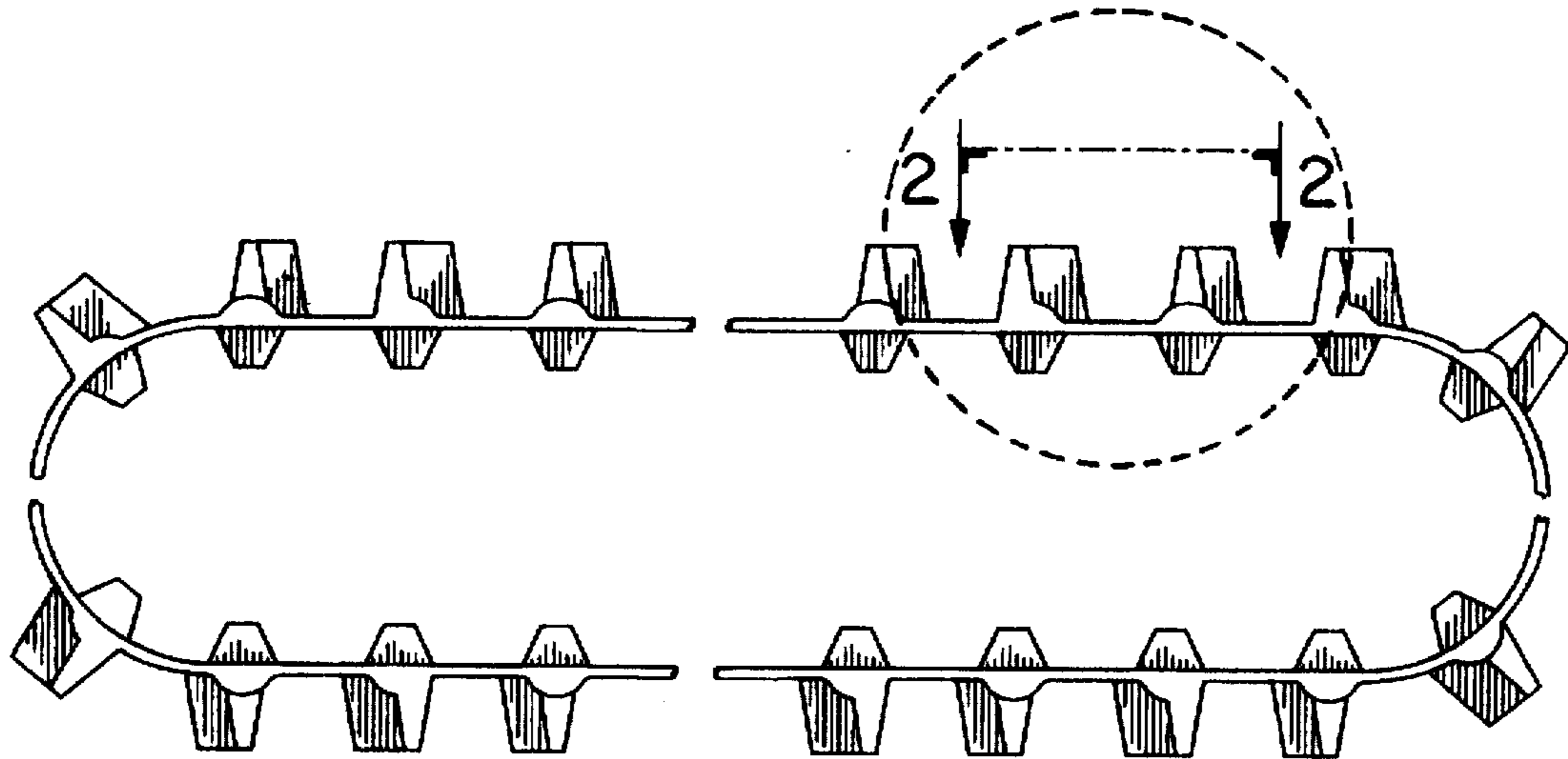

FIG. 1

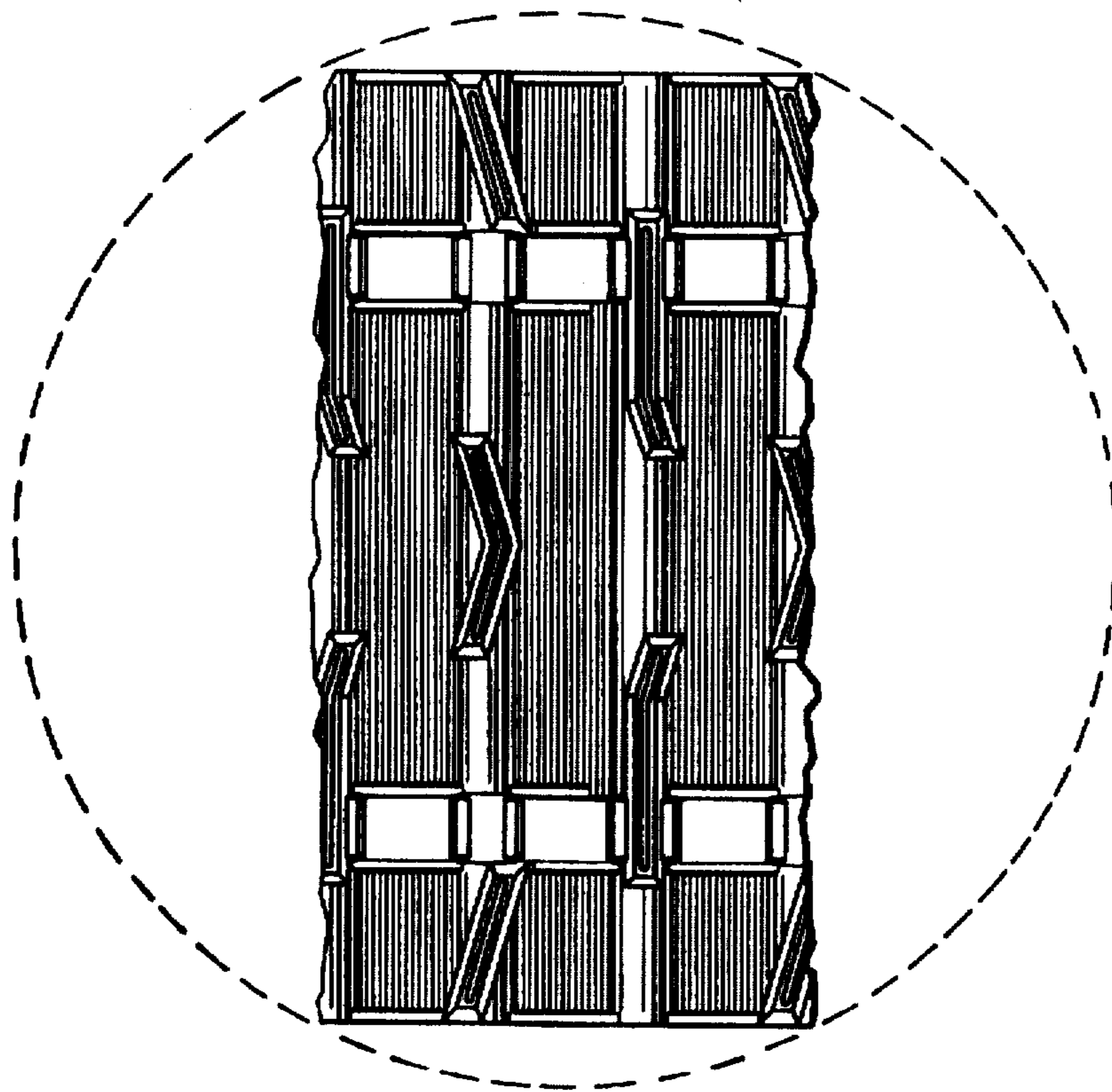

FIG. 2

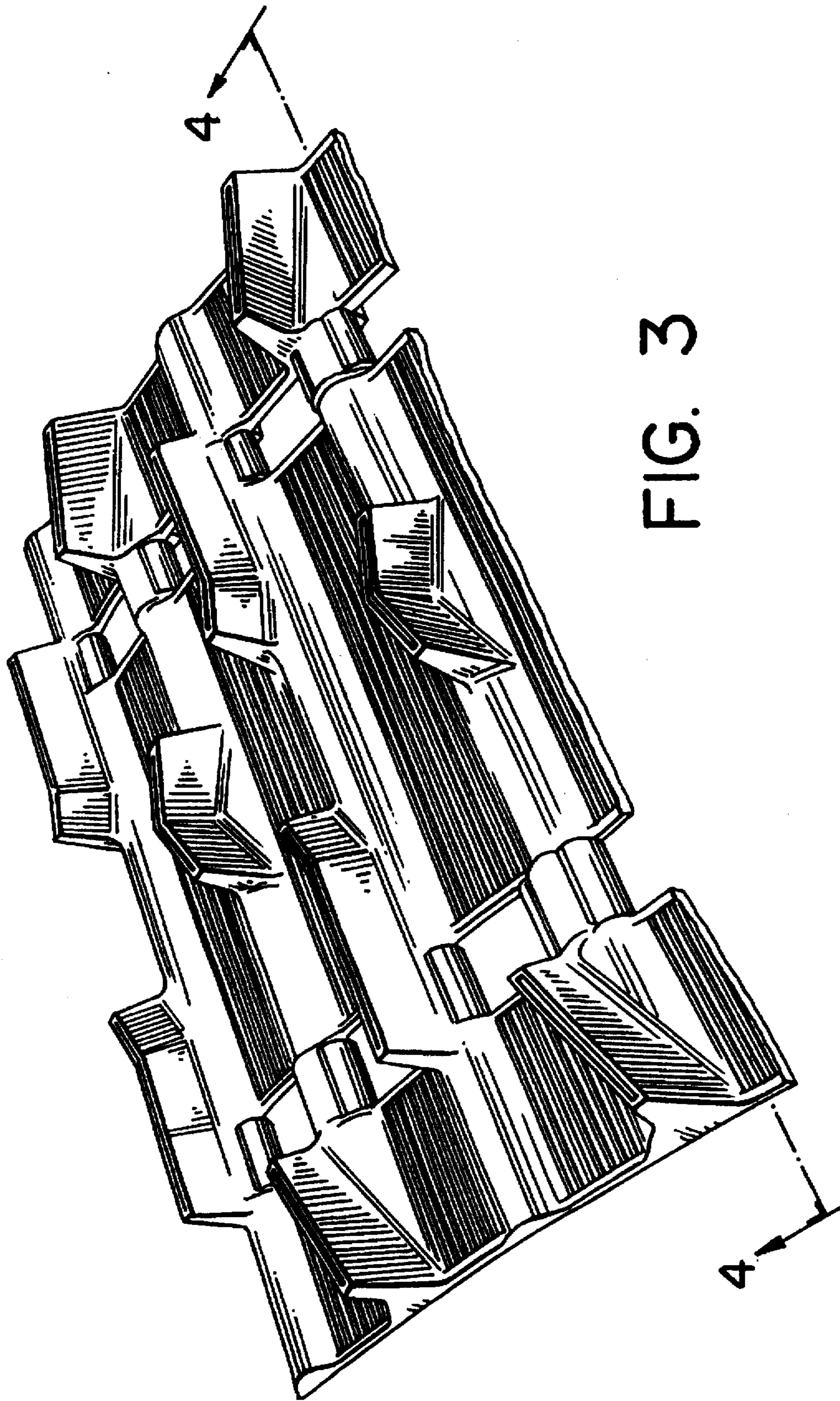

FIG. 3

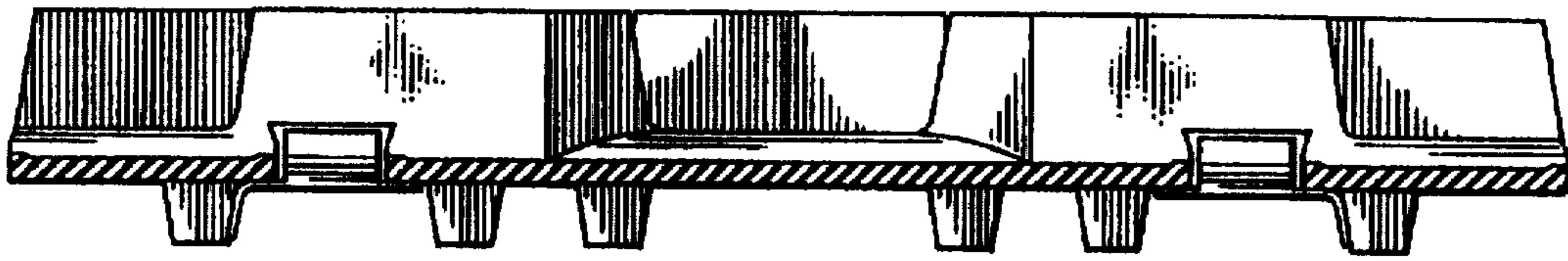

FIG. 4

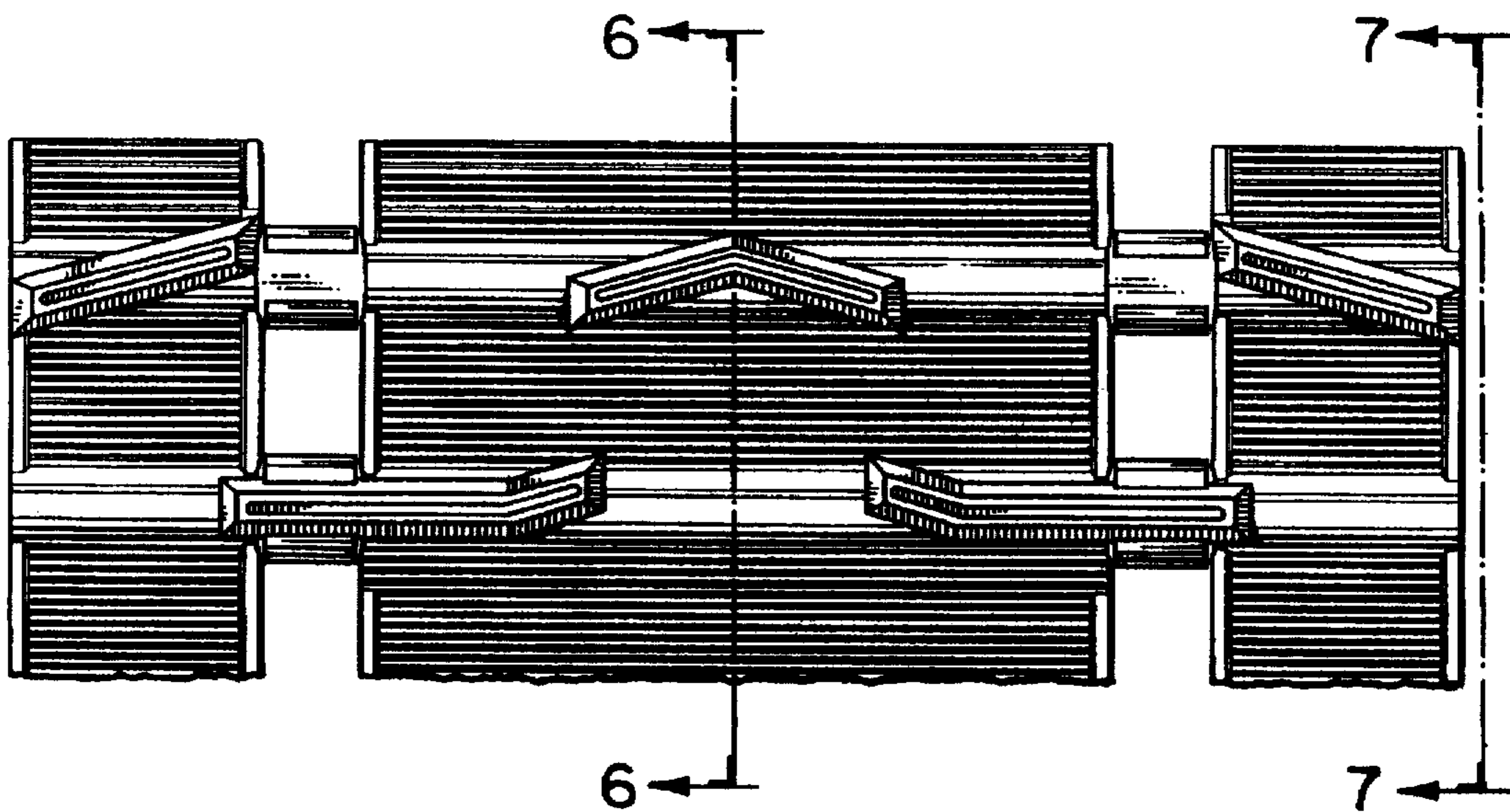

FIG. 5

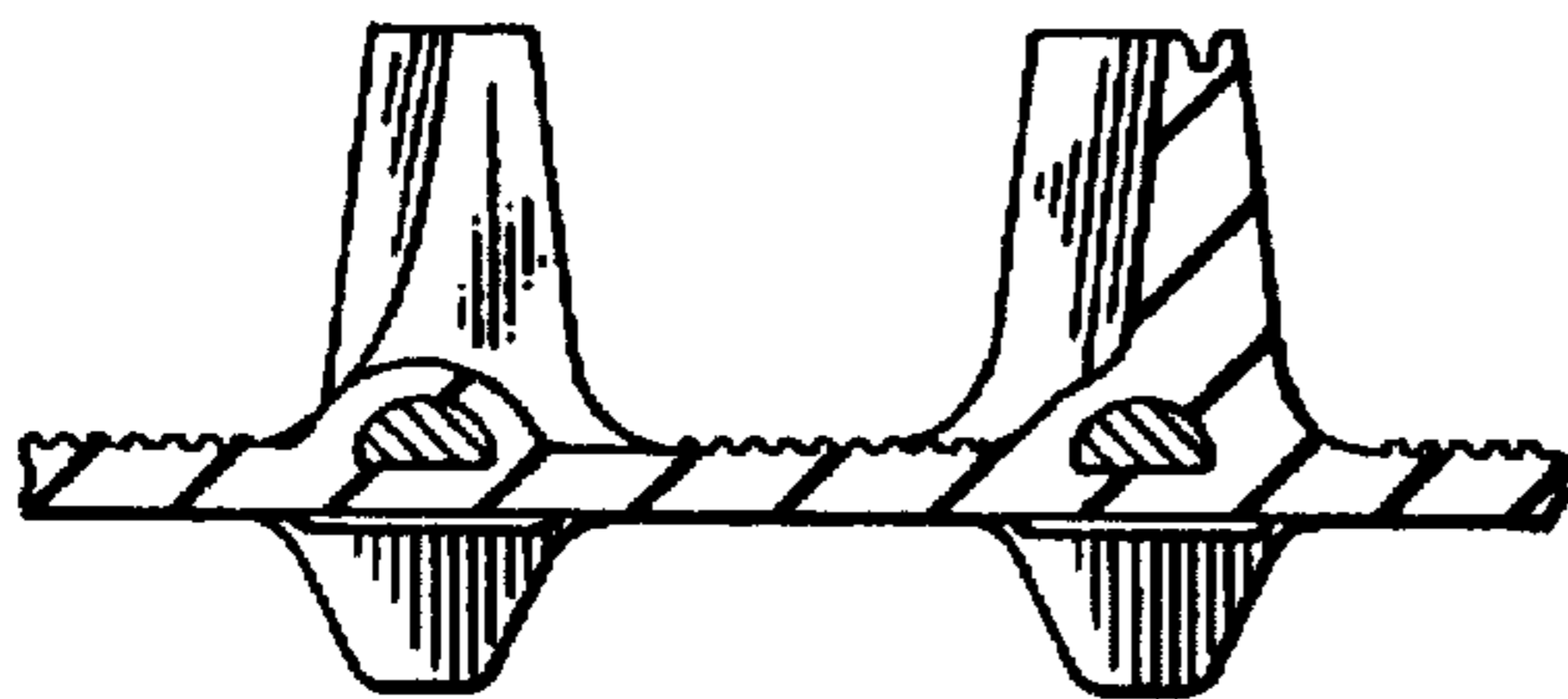

FIG. 6

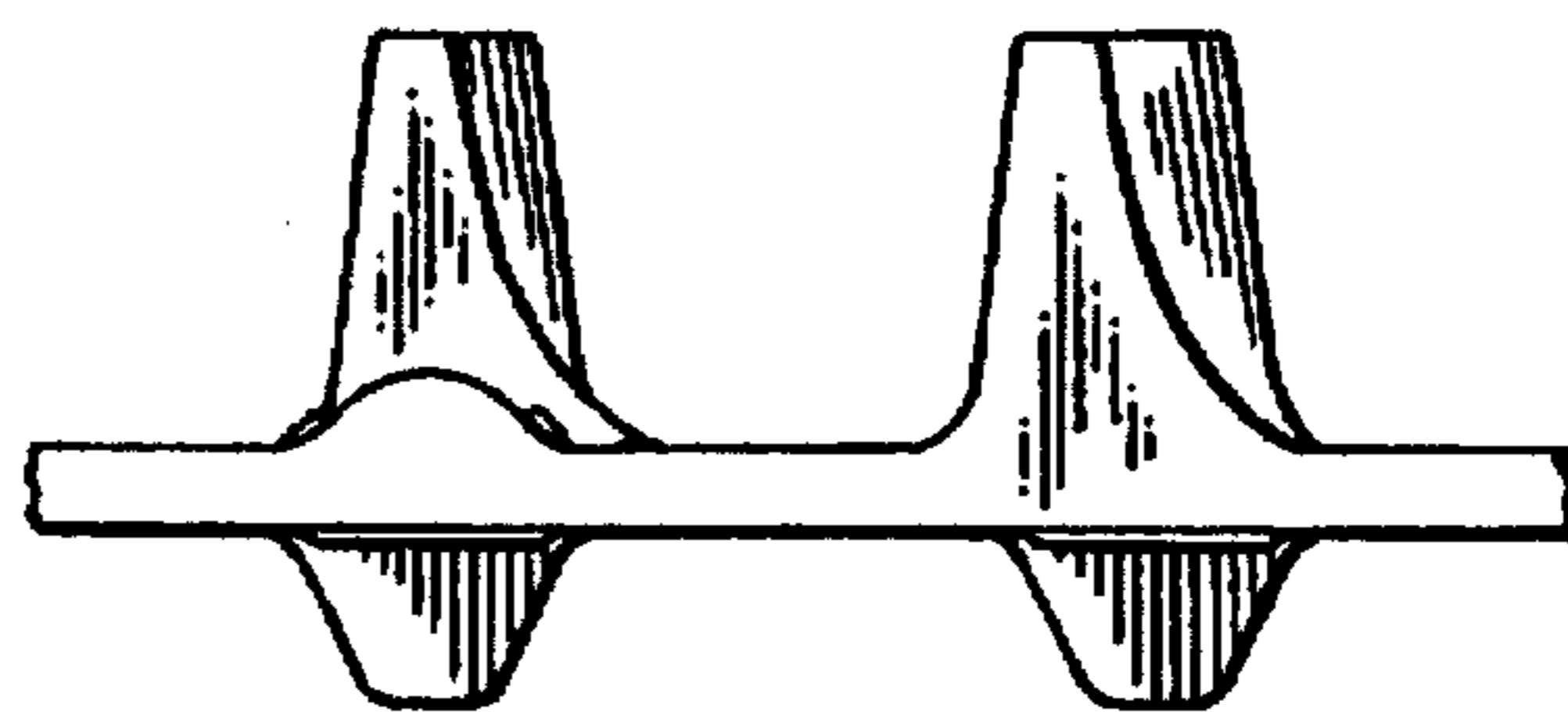

FIG. 7

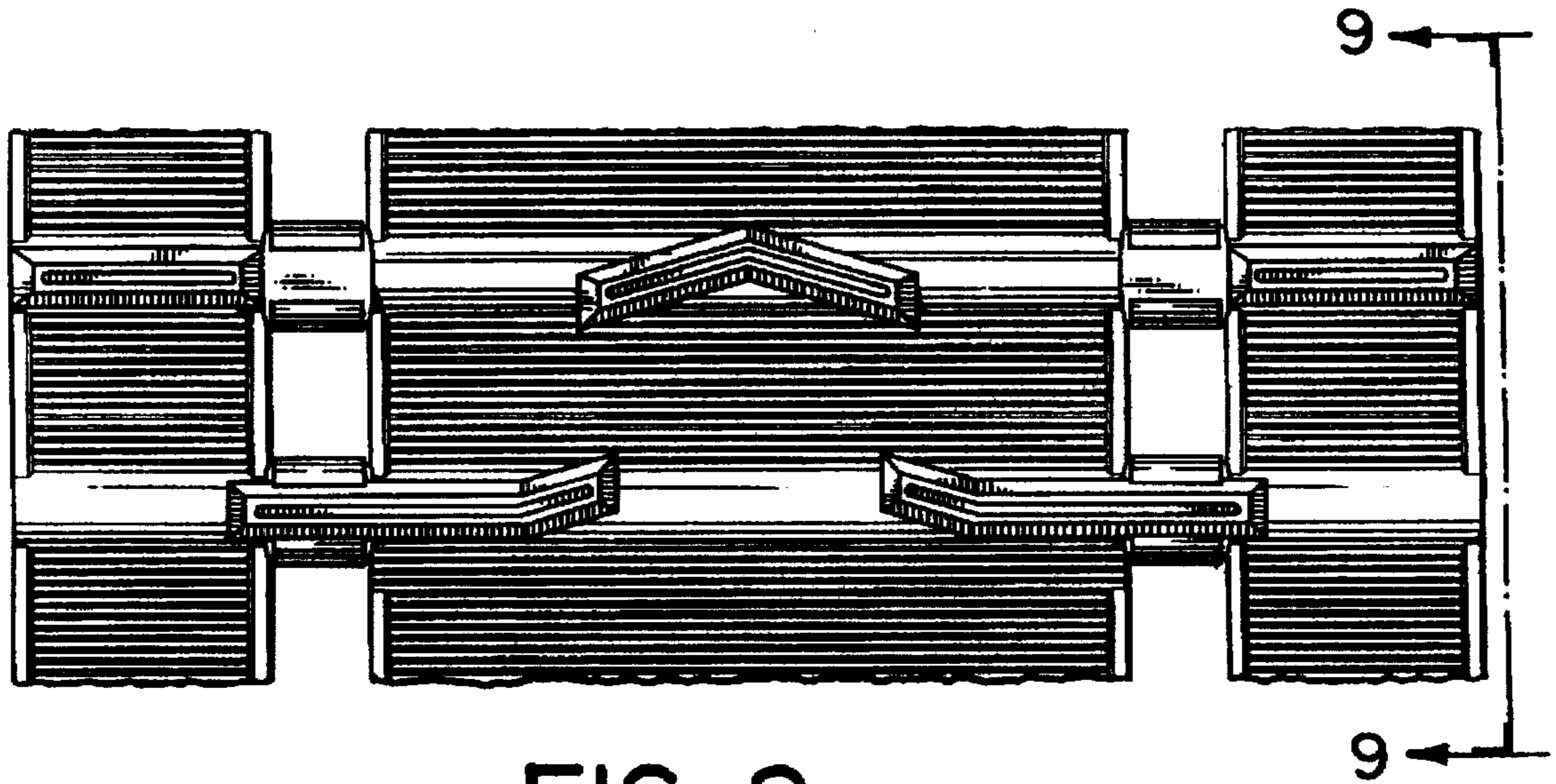

FIG. 8

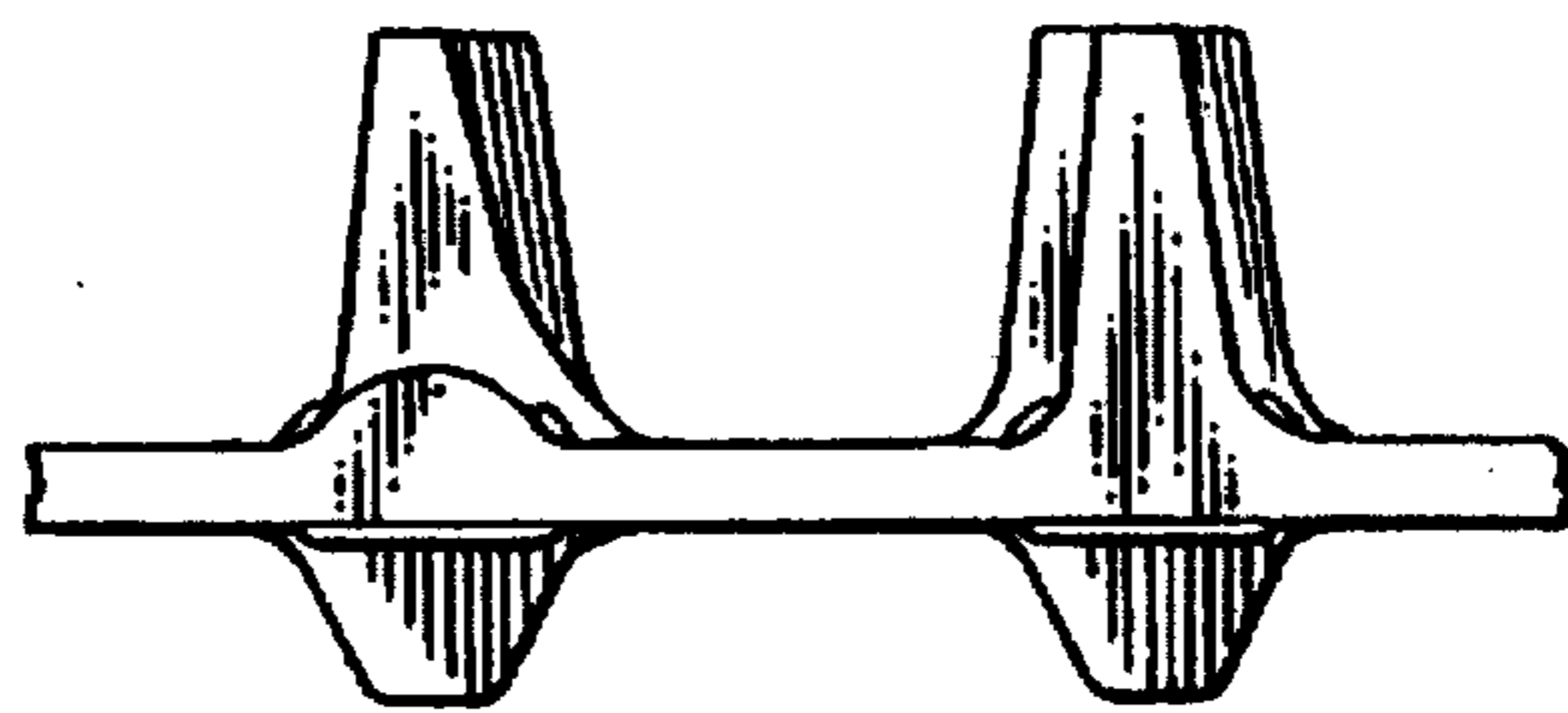

FIG. 9