



US00D386696S

United States Patent [19]
Walch

[11] **Patent Number: Des. 386,696**
[45] **Date of Patent: **Nov. 25, 1997**

[54] **MULTIPIECE PLASTIC WRISTWATCH**

[76] **Inventor: Christophe Walch, St. Alban-Rheinweg
170, CH-4052 Basel, Switzerland**

[**] **Term: 14 Years**

[21] **Appl. No.: 42,655**

[22] **Filed: Aug. 16, 1995**

[30] **Foreign Application Priority Data**

Feb. 16, 1995 [DK] Denmark 4940024

[51] **LOC (6) Cl. 10-02**

[52] **U.S. Cl. D10/32; D10/39**

[58] **Field of Search D10/1-40, 122-132;
368/276-277, 280-282, 285; D11/3-4,
12, 14, 19-25; 63/1.1, 3, 5.1, 11**

[56] **References Cited**

U.S. PATENT DOCUMENTS

D. 285,422 9/1986 Grimes D11/4
D. 323,785 2/1992 Tse D10/32

D. 349,257 8/1994 Polenberg D11/3
D. 361,281 8/1995 Rotti D10/39

OTHER PUBLICATIONS

Hong Kong Enterprise-Mar. 1987-p. 217-Watches.
Hong Kong Enterprise-Mar. 1987-p. 192-Watches.

Primary Examiner-Nelson C. Holtje
Attorney, Agent, or Firm-Limbach & Limbach L.L.P.

[57] **CLAIM**

The ornamental design for a multipiece plastic wristwatch, as shown and described.

DESCRIPTION

FIG. 1 is a top and left side perspective view of a watch showing my new design;
FIG. 2 is a top plan view thereof;
FIG. 3 is a bottom plan view thereof;
FIG. 4 is a right side elevational view of FIG. 2;
FIG. 5 is a left side elevational view of FIG. 2; and
FIG. 6 is a right side elevational view thereof.

1 Claim, 2 Drawing Sheets

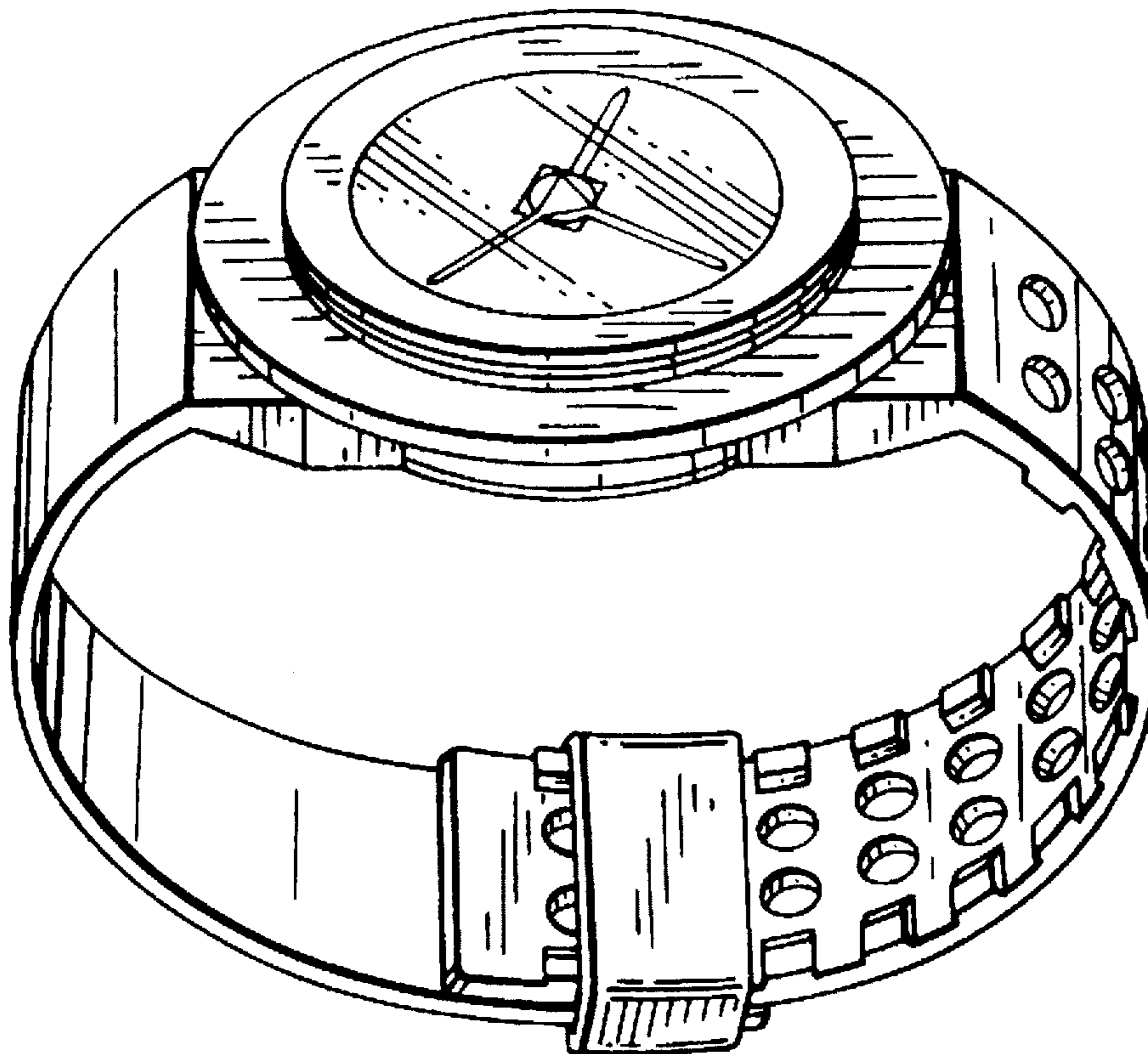

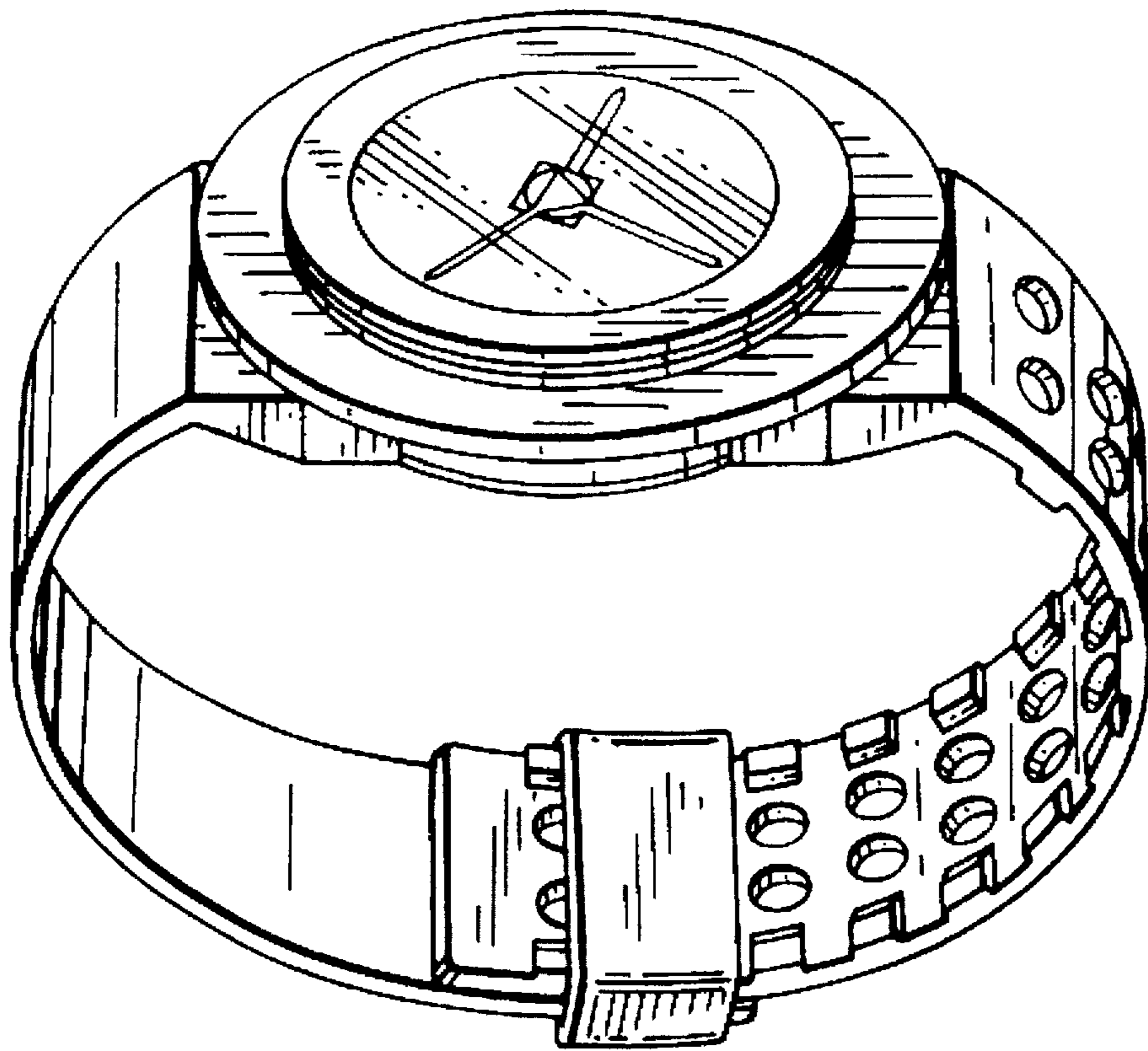

FIG. 1

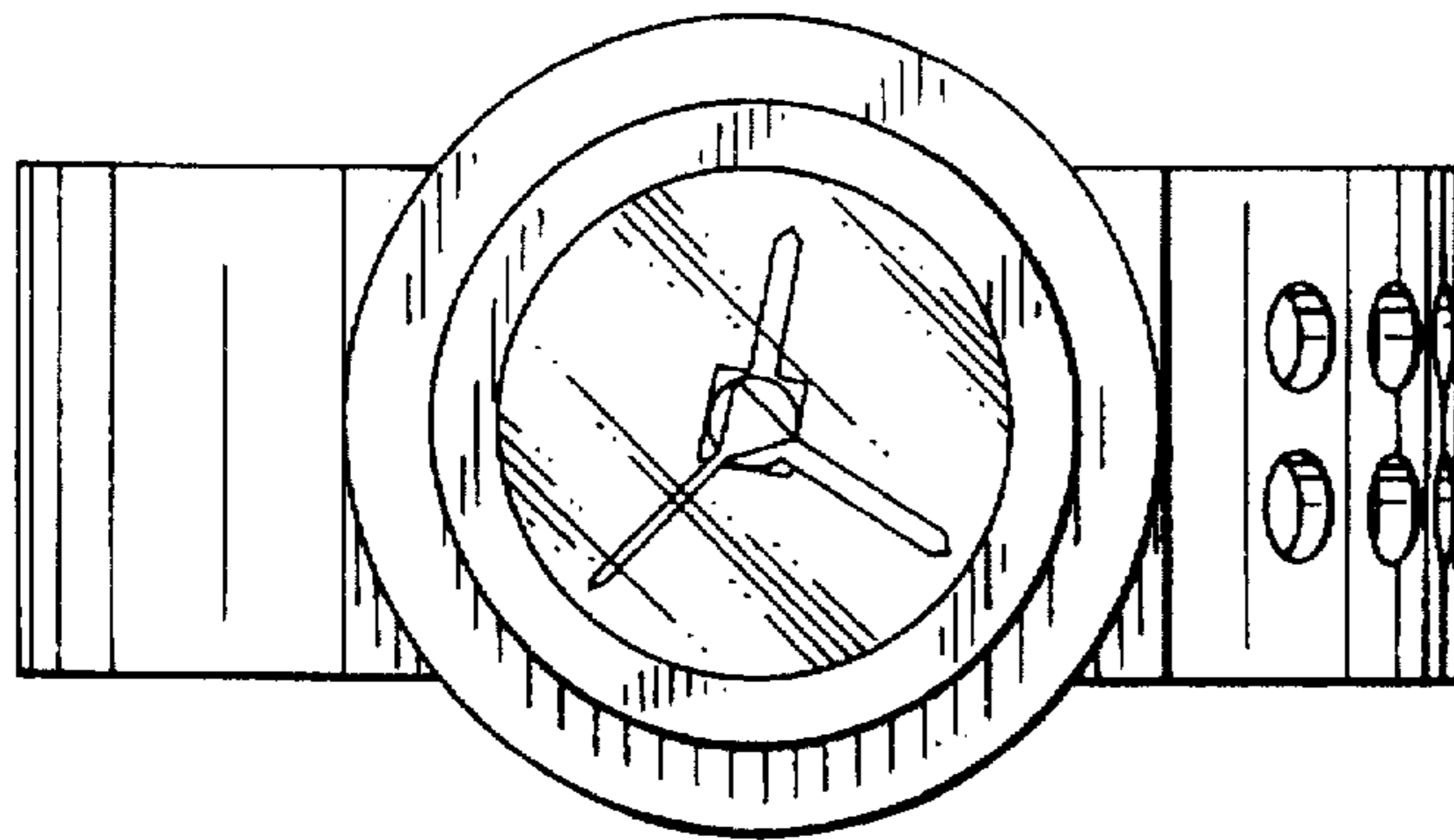

FIG. 2

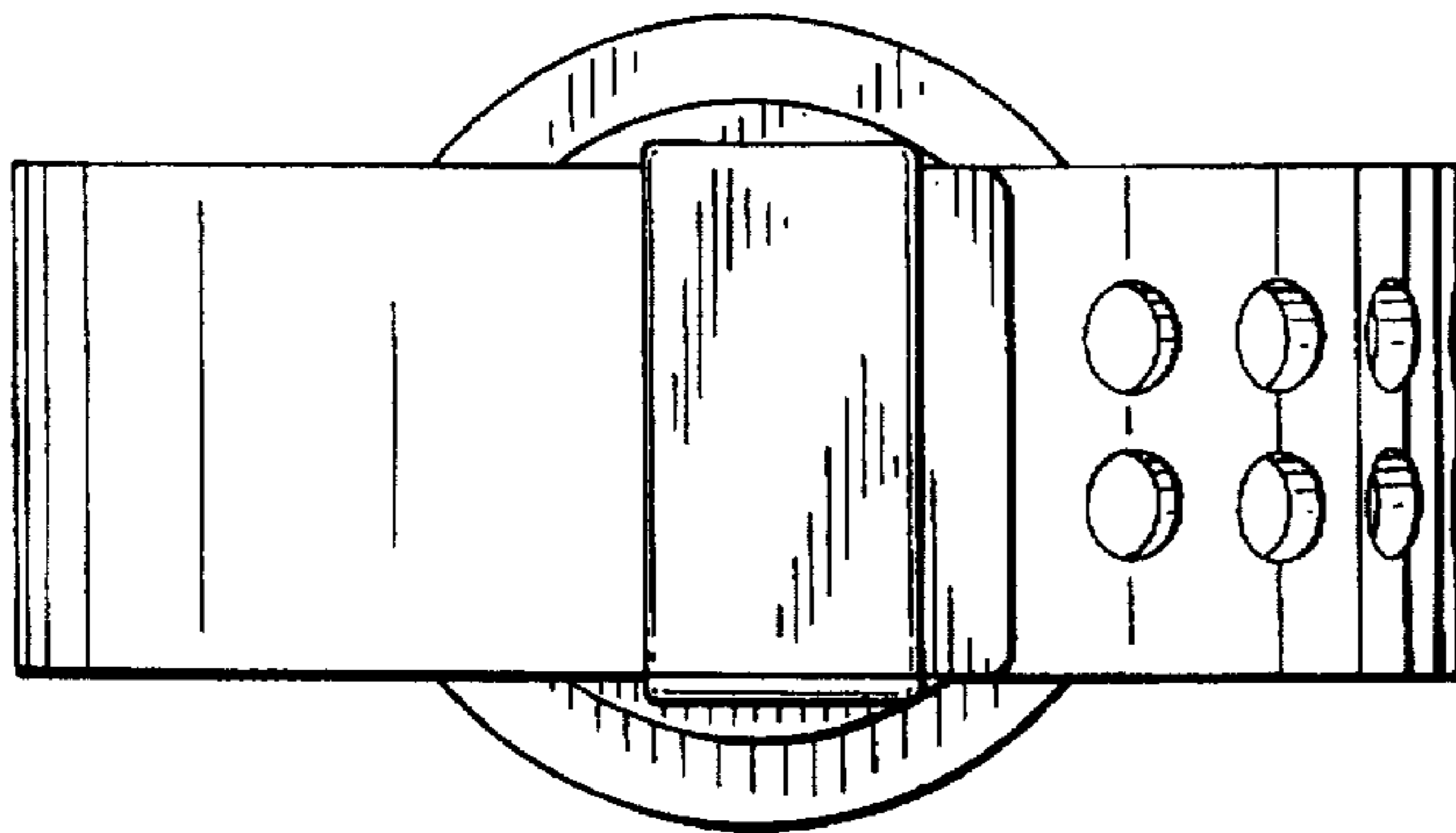

FIG. 3

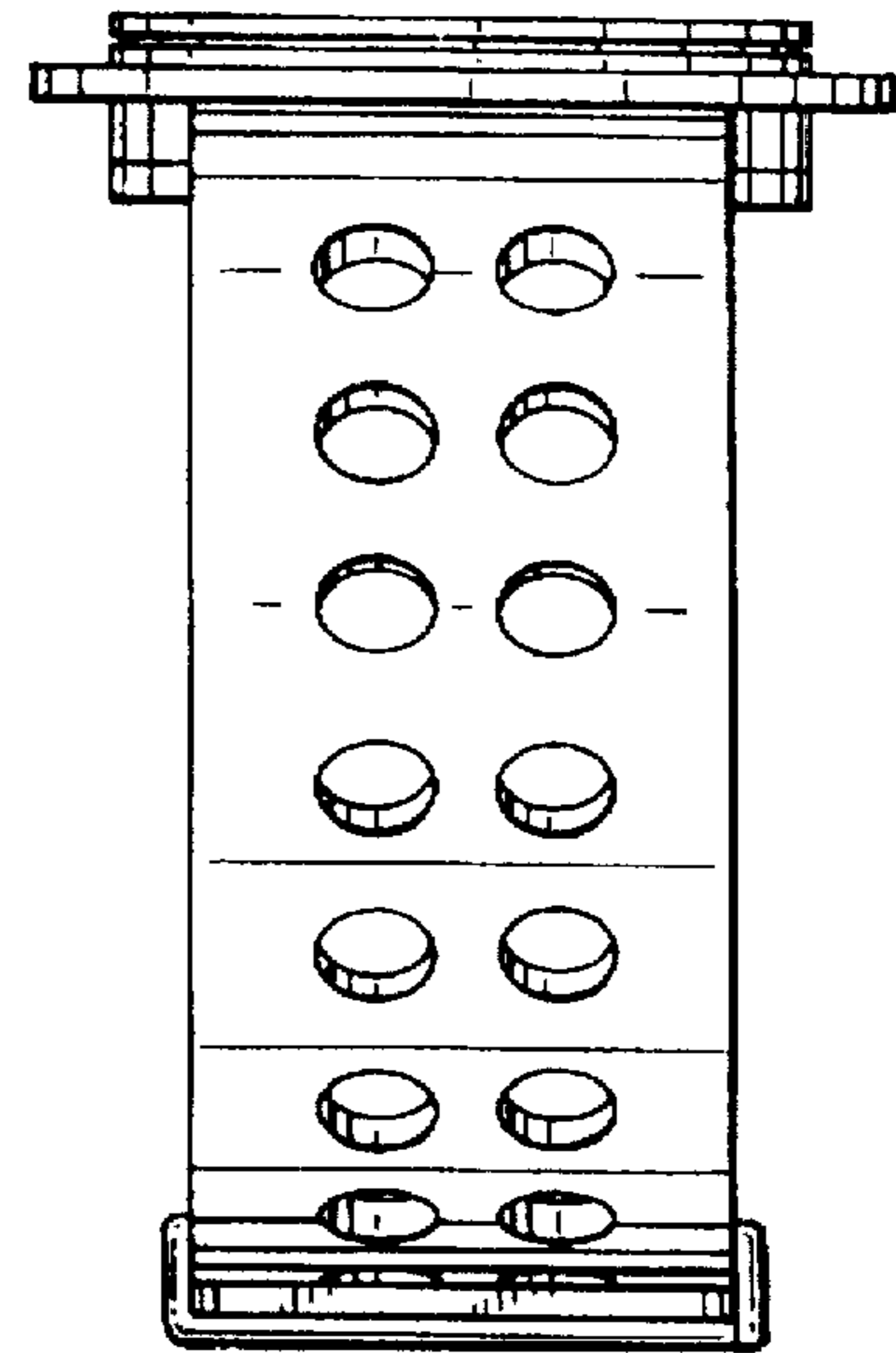

FIG. 4

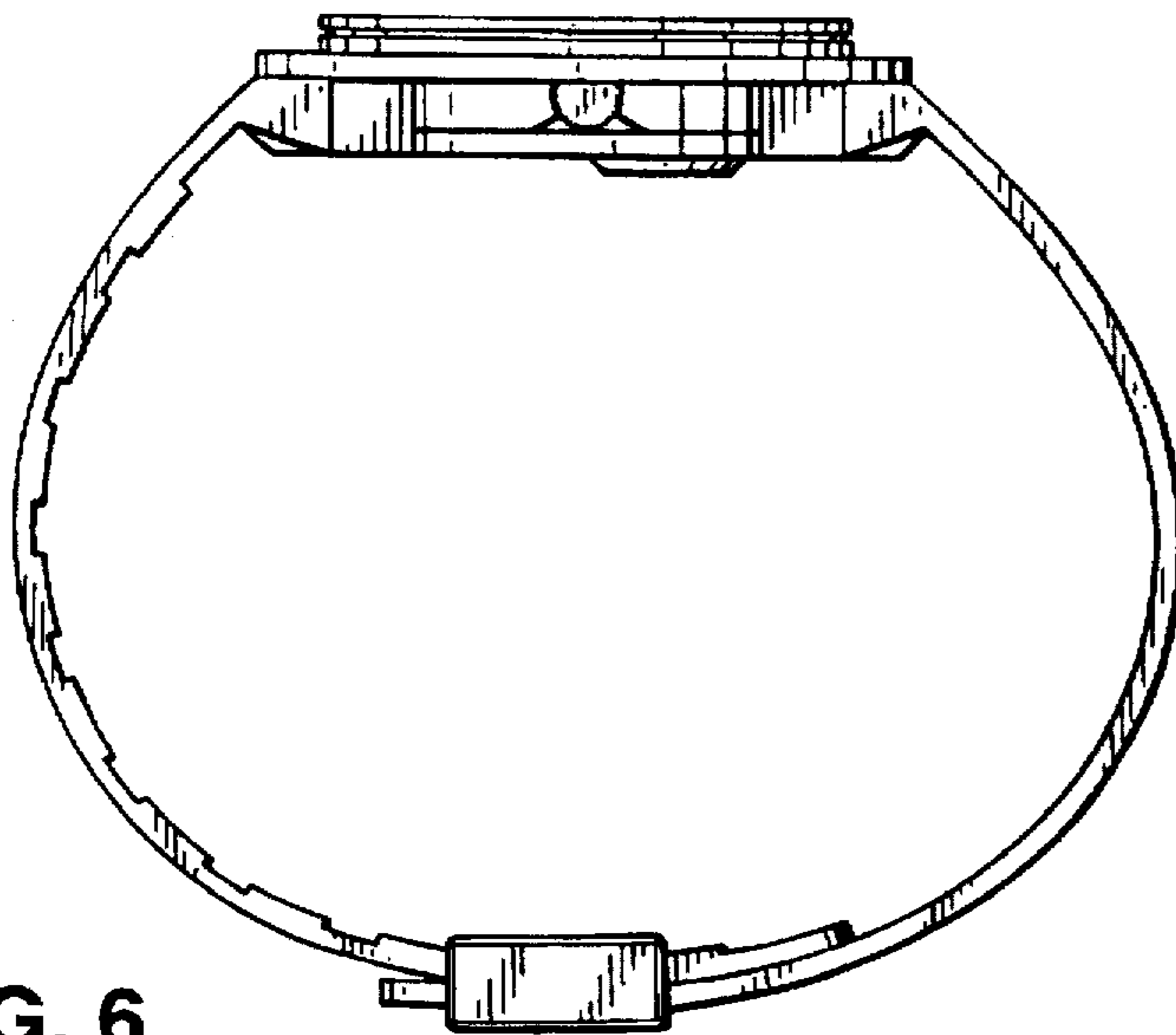

FIG. 6

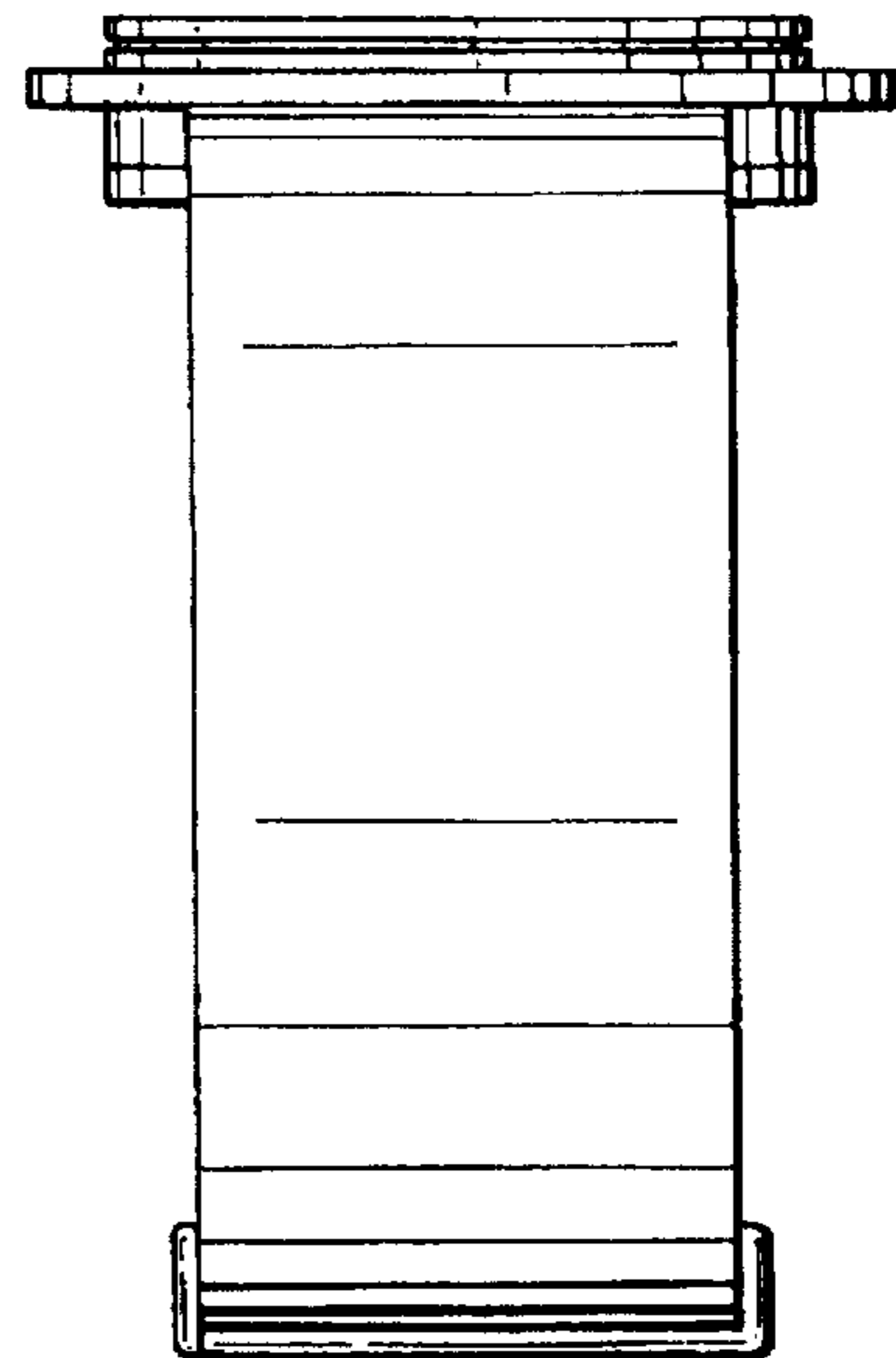

FIG. 5