



US00D386586S

United States Patent [19]
Jensen

[11] **Patent Number: Des. 386,586**

[45] **Date of Patent: **Nov. 25, 1997**

[54] **HAT SPRINT CAR WING**

[76] **Inventor: Curt K. Jensen, 3210 Frontier Pl.,
Rapid City, S. Dak. 57702**

[**] **Term: 14 Years**

[21] **Appl. No.: 58,816**

[22] **Filed: Aug. 23, 1996**

[51] **LOC (6) Cl. 02-03**

[52] **U.S. Cl. D2/866**

[58] **Field of Search D2/865, 866, 869;
2/195.1, 195.5**

[56] **References Cited**

U.S. PATENT DOCUMENTS

- D. 282,405 2/1986 De Lozada D2/866
- D. 285,141 8/1986 Whisman D2/866

- D. 352,378 11/1994 Wise D2/869 X
- 1,428,453 9/1922 Schwarz et al. 2/195.5
- 1,493,463 5/1924 Brock 2/195.5 X
- 2,289,370 7/1942 Krag D2/865 X
- 5,493,733 2/1996 Pospisil 2/195.1

*Primary Examiner—Paula A. Mortimer
Attorney, Agent, or Firm—Gene R. Woodle*

[57] **CLAIM**

The ornamental design for a hat sprint car wing, as shown and described.

DESCRIPTION

FIG. 1 is a front side perspective view of a hat sprint car wing showing my new design;
FIG. 2 is a front elevational view thereof; and,
FIG. 3 is a top view thereof.

1 Claim, 2 Drawing Sheets

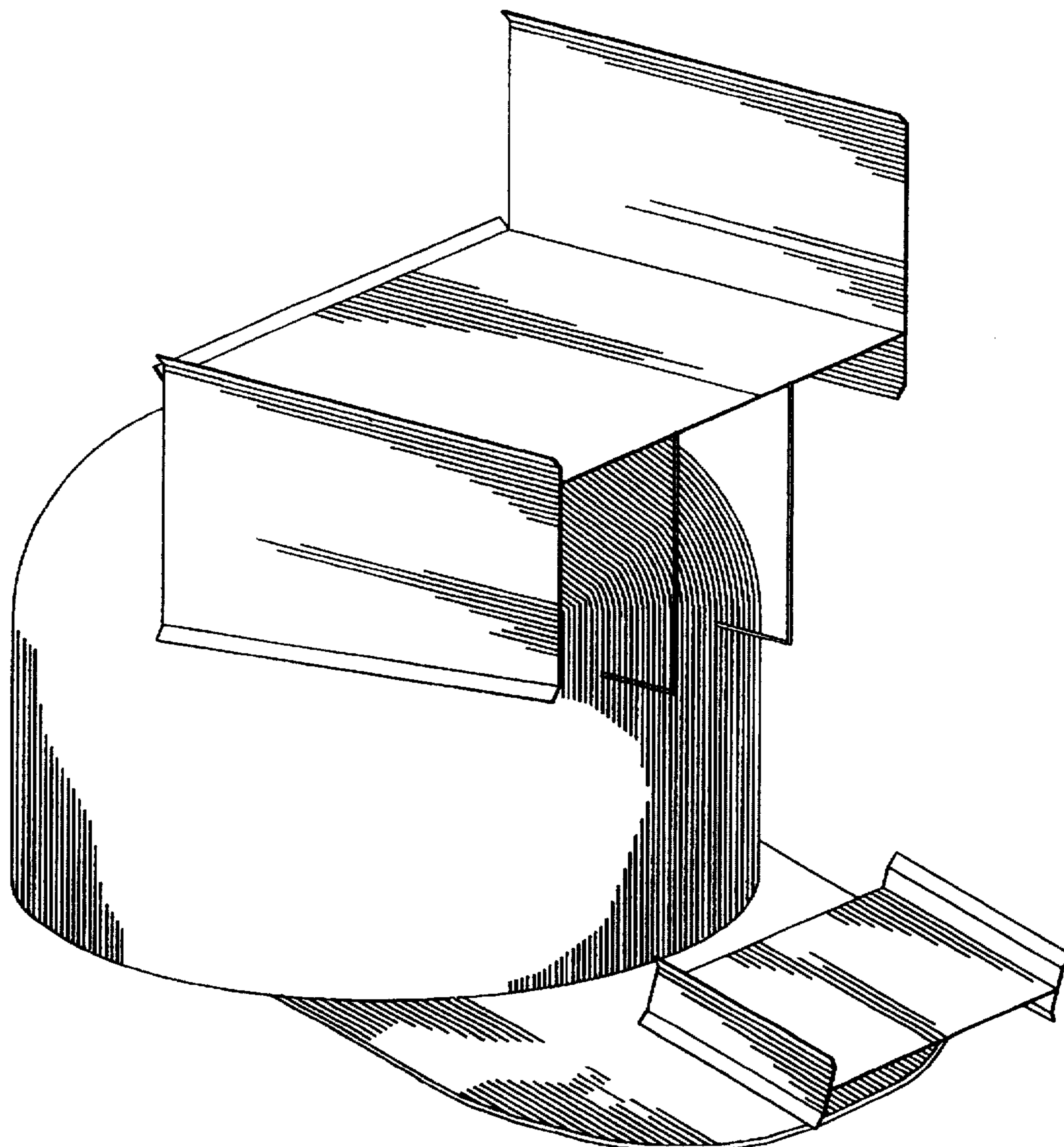

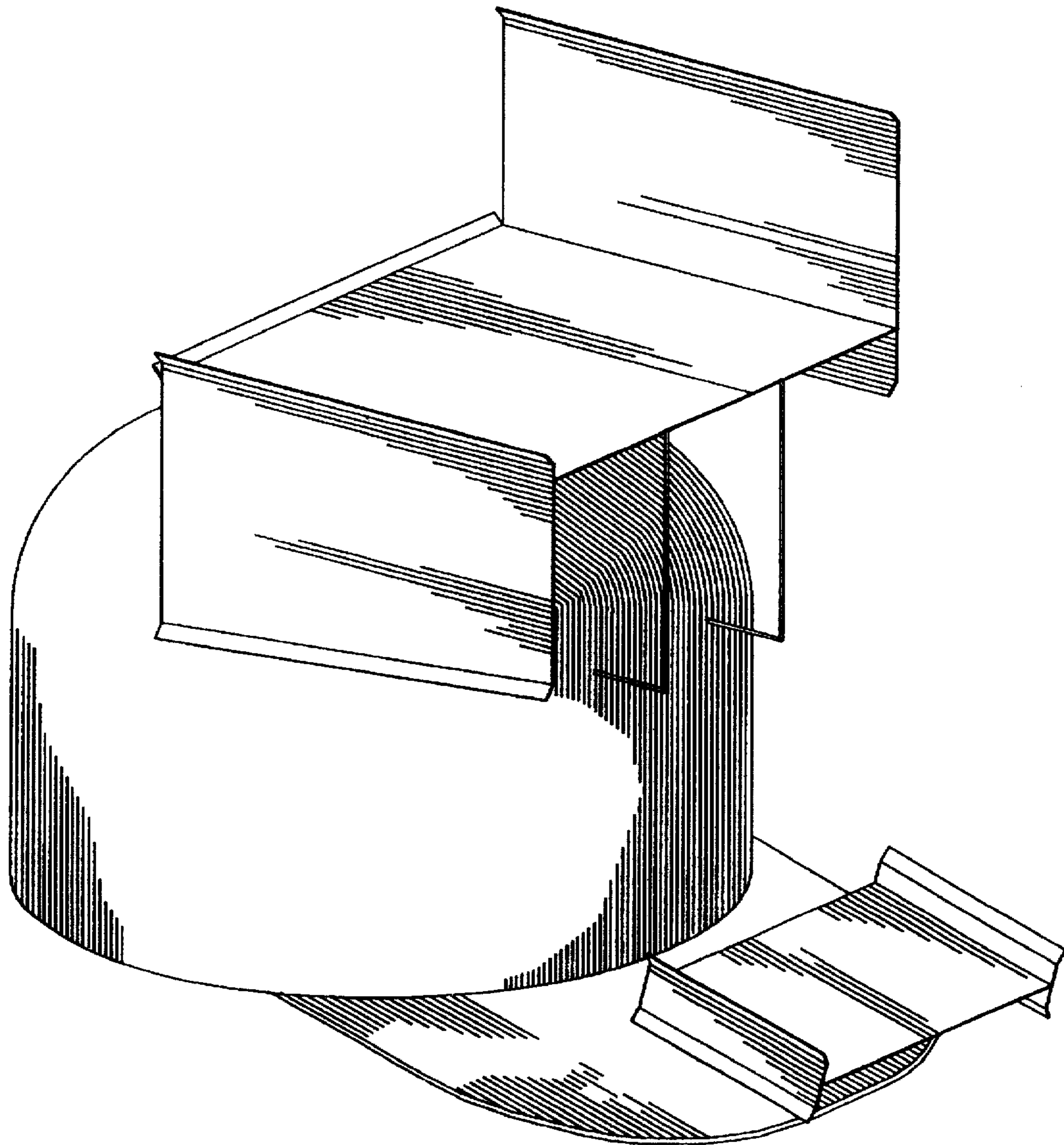

FIG. 1

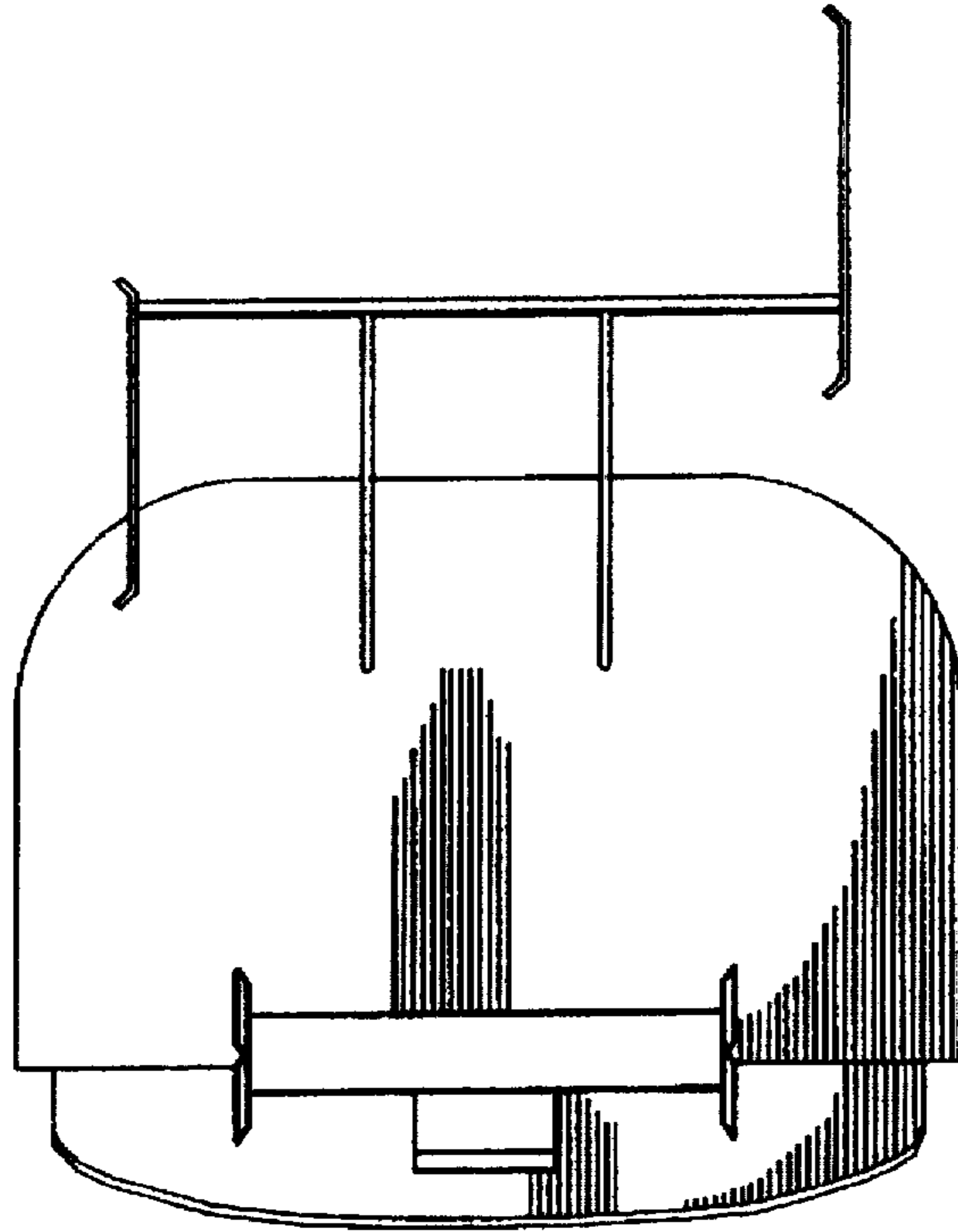

FIG. 2

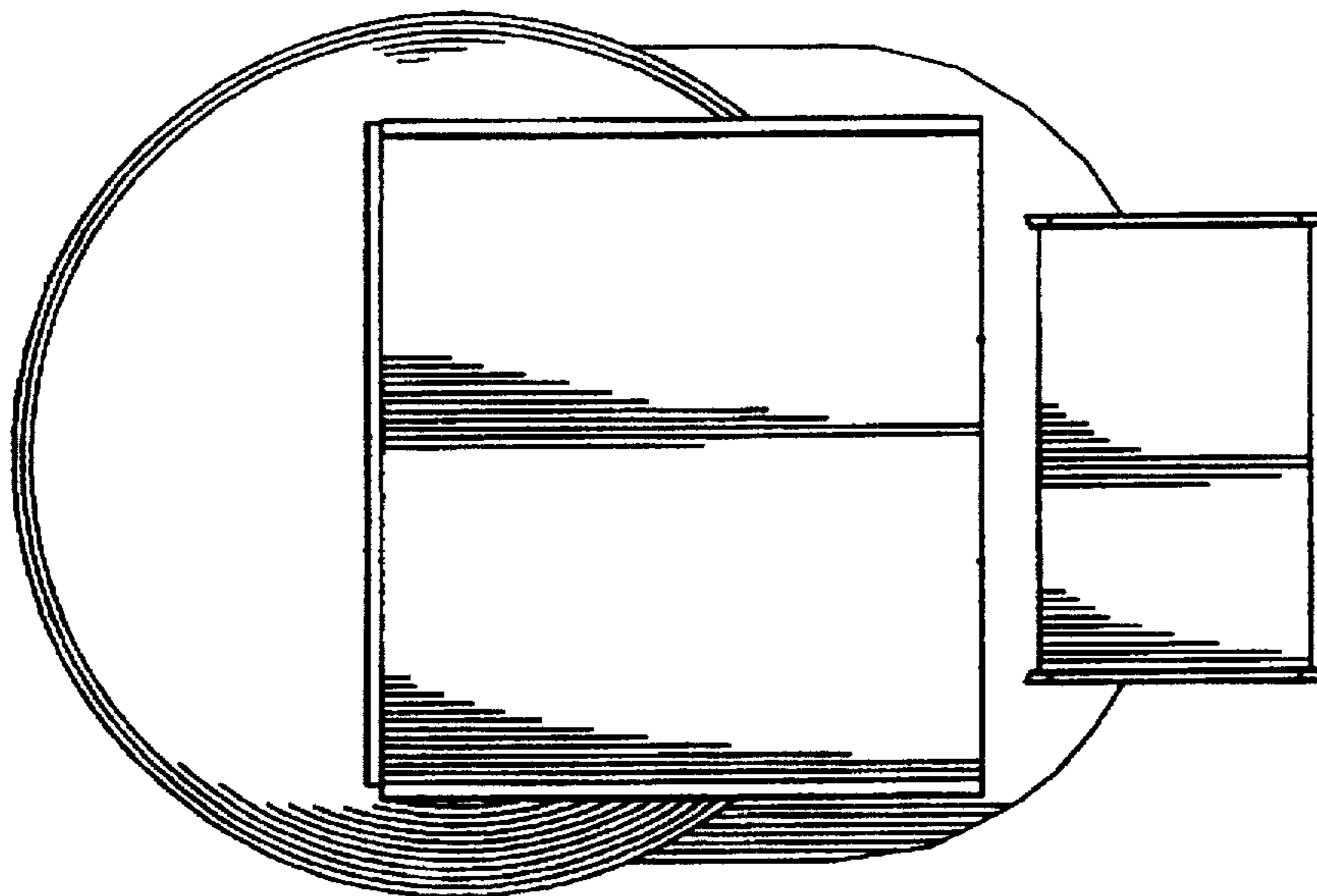

FIG. 3