

US00D386463S

United States Patent [19]

[11] Patent Number: Des. 386,463

Garrard et al.

[45] Date of Patent: **Nov. 18, 1997

[54] **FUEL FILTER WITH POP-OUT INDICATOR**

Primary Examiner—Marcus A. Jackson
Attorney, Agent, or Firm—Kalish & Gilster

[75] Inventors: **James H. Garrard**, Kirkwood; **Steve R. Pinkston**, House Springs, both of Mo.

[57] **CLAIM**

The design for a fuel filter with pop-out indicator, as shown and described.

[73] Assignee: **Essex Industries, Inc.**, St. Louis, Mo.

[**] Term: **14 Years**

DESCRIPTION

[21] Appl. No.: **24,416**

FIG. 1 is an elevational view showing our new design;

[22] Filed: **Jun. 14, 1994**

FIG. 2 is an enlarged partial perspective view from the left side thereof;

[51] LOC (6) Cl. **12-06**

[52] U.S. Cl. **D12/218**

FIG. 3 is an enlarged partial perspective view from the right side thereof;

[58] Field of Search **D12/218, 213, D12/220; 73/327**

FIG. 4 is a left elevational end view of FIG. 1; and,

[56] **References Cited**

FIG. 5 is a right elevational end view of FIG. 1.

U.S. PATENT DOCUMENTS

- D. 262,956 2/1982 McNabe et al. D12/218
- D. 272,447 1/1984 Ashmore D12/218

1 Claim, 1 Drawing Sheet

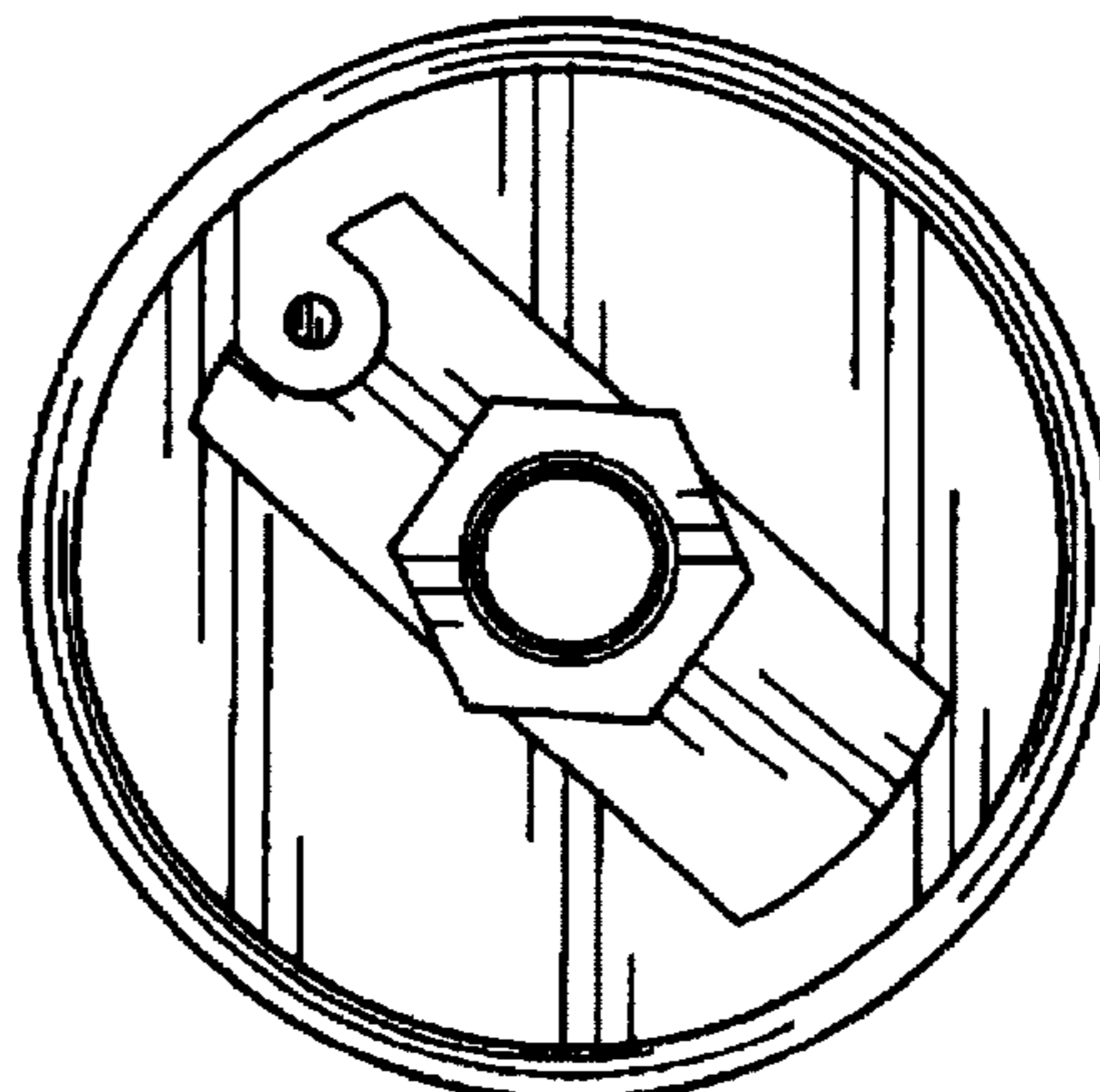
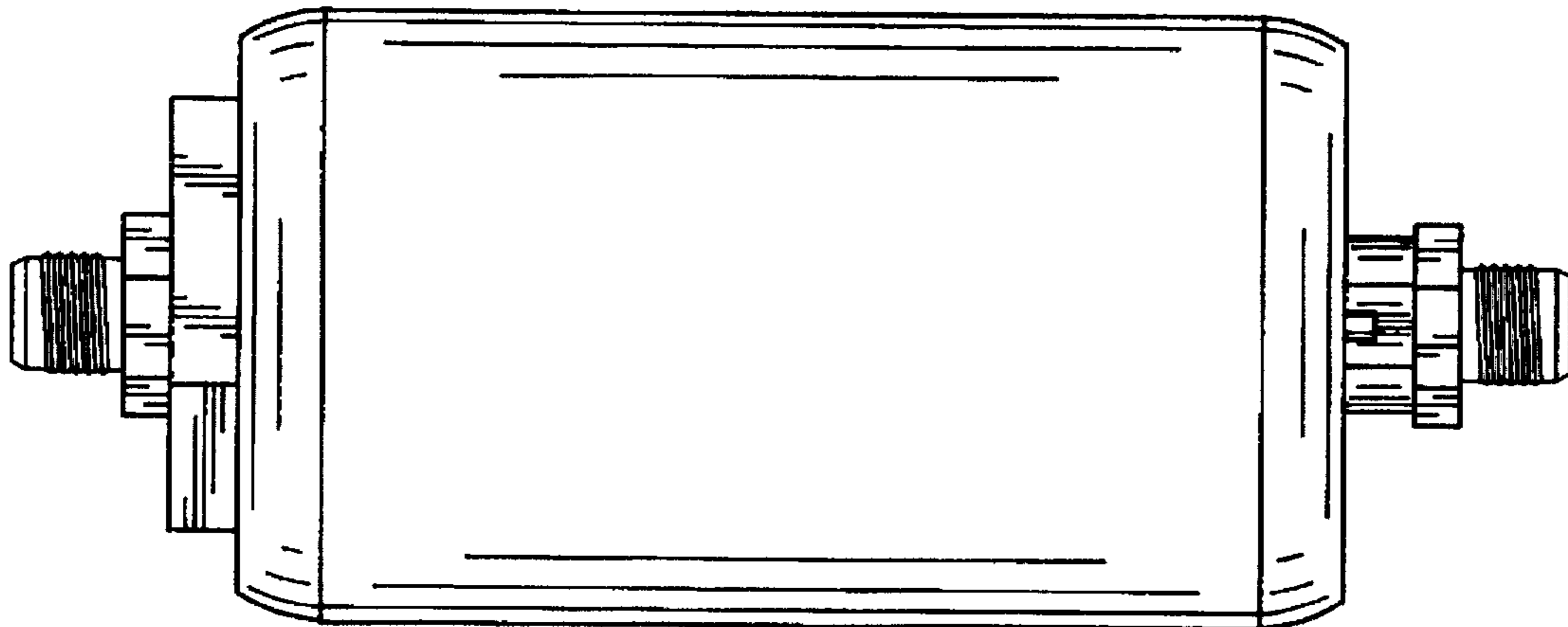

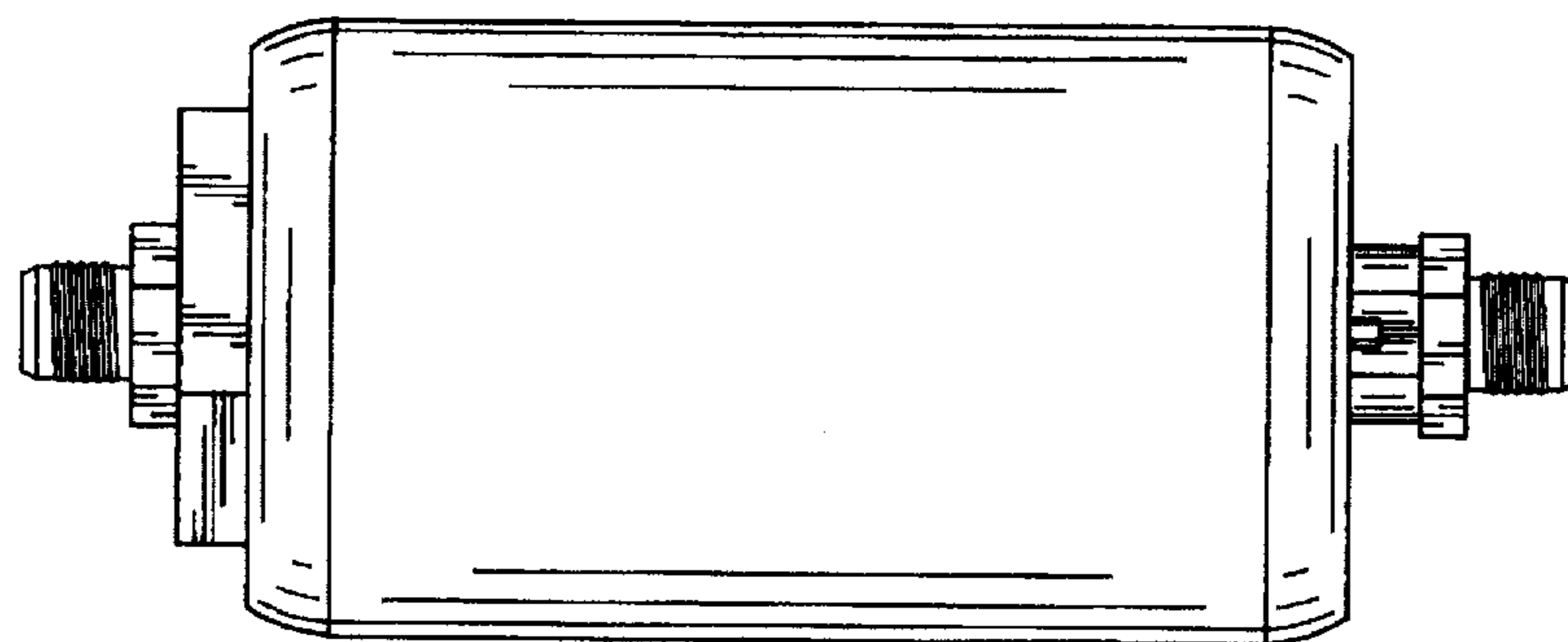

FIG. 1

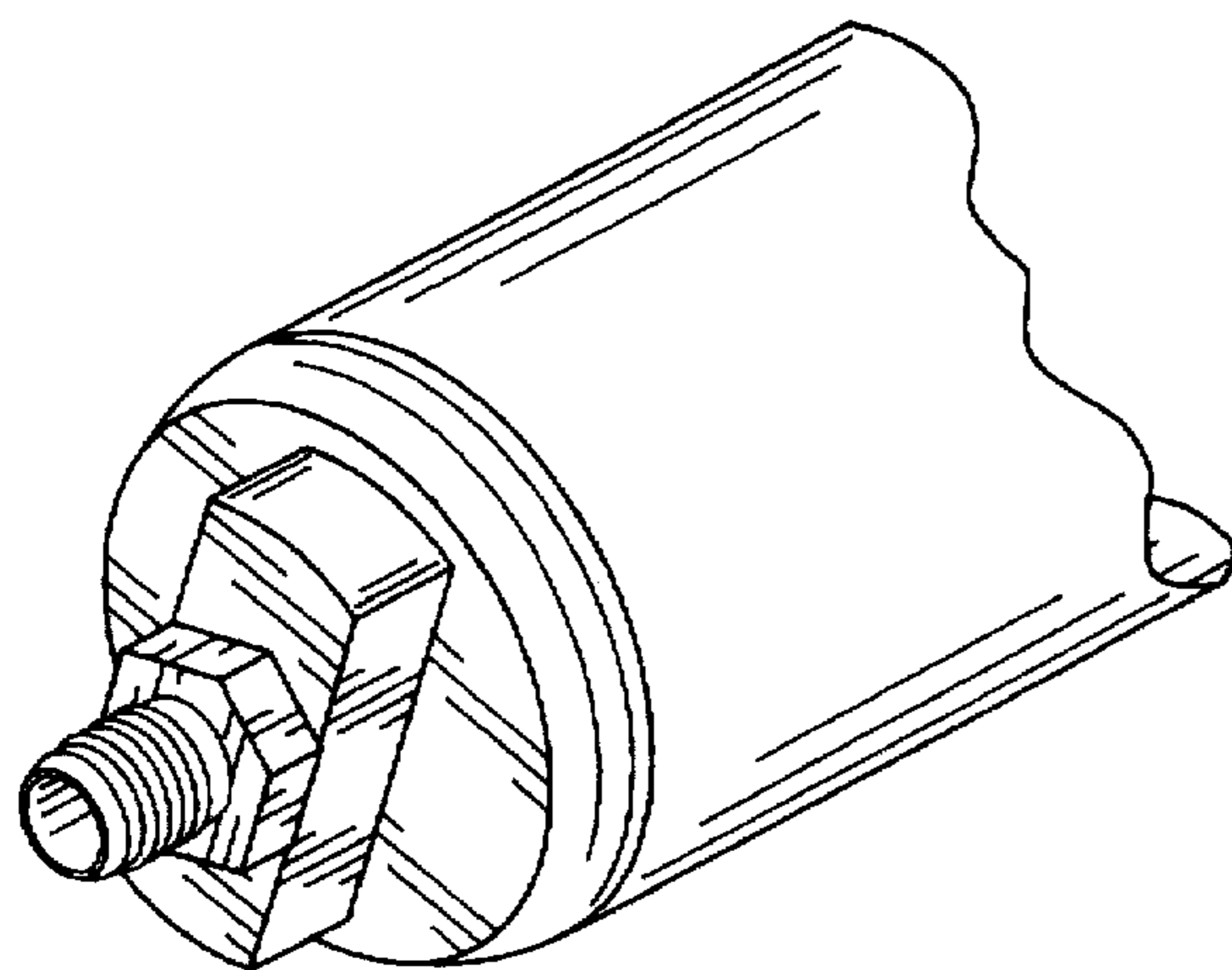

FIG. 2

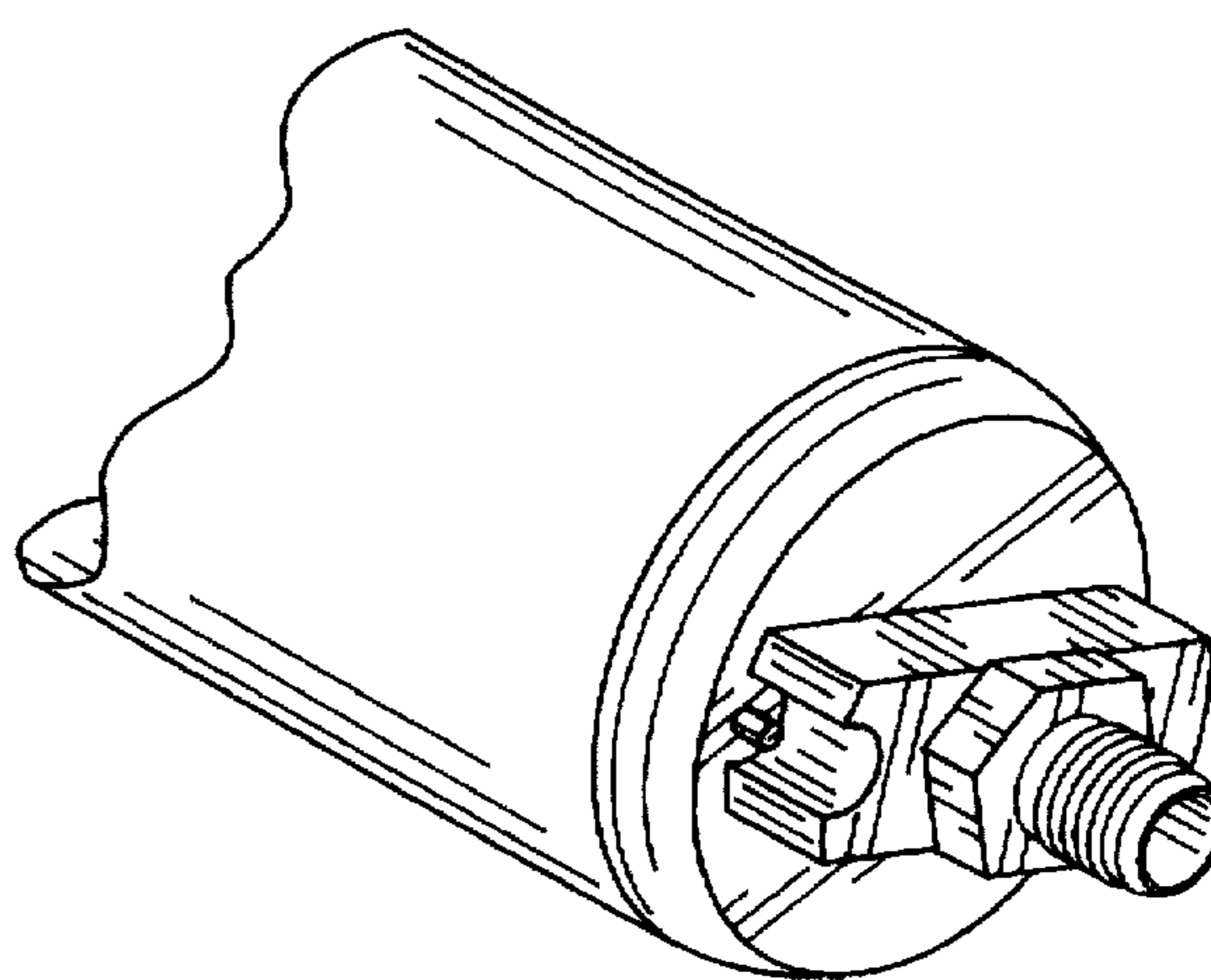

FIG. 3

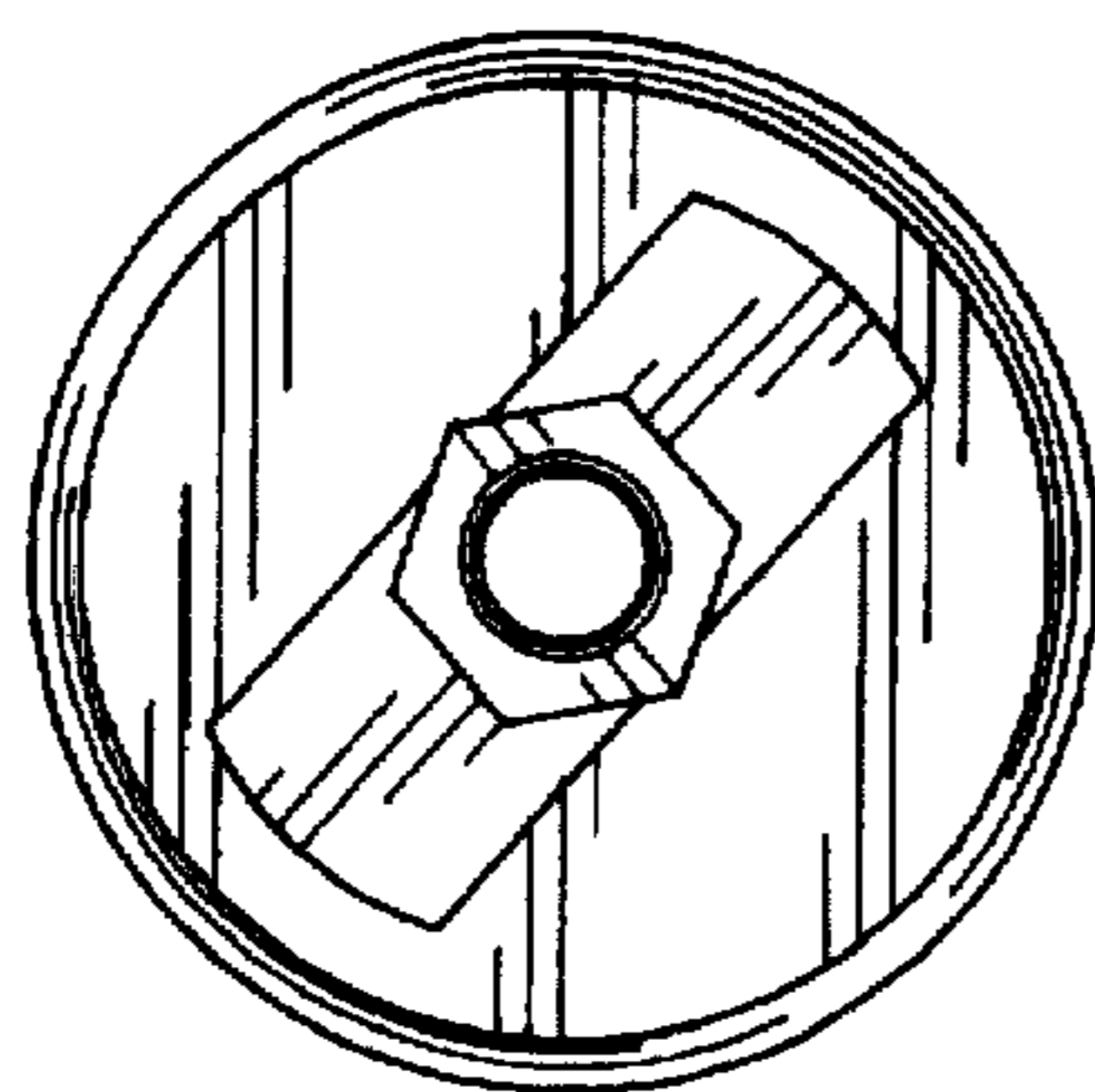

FIG. 4

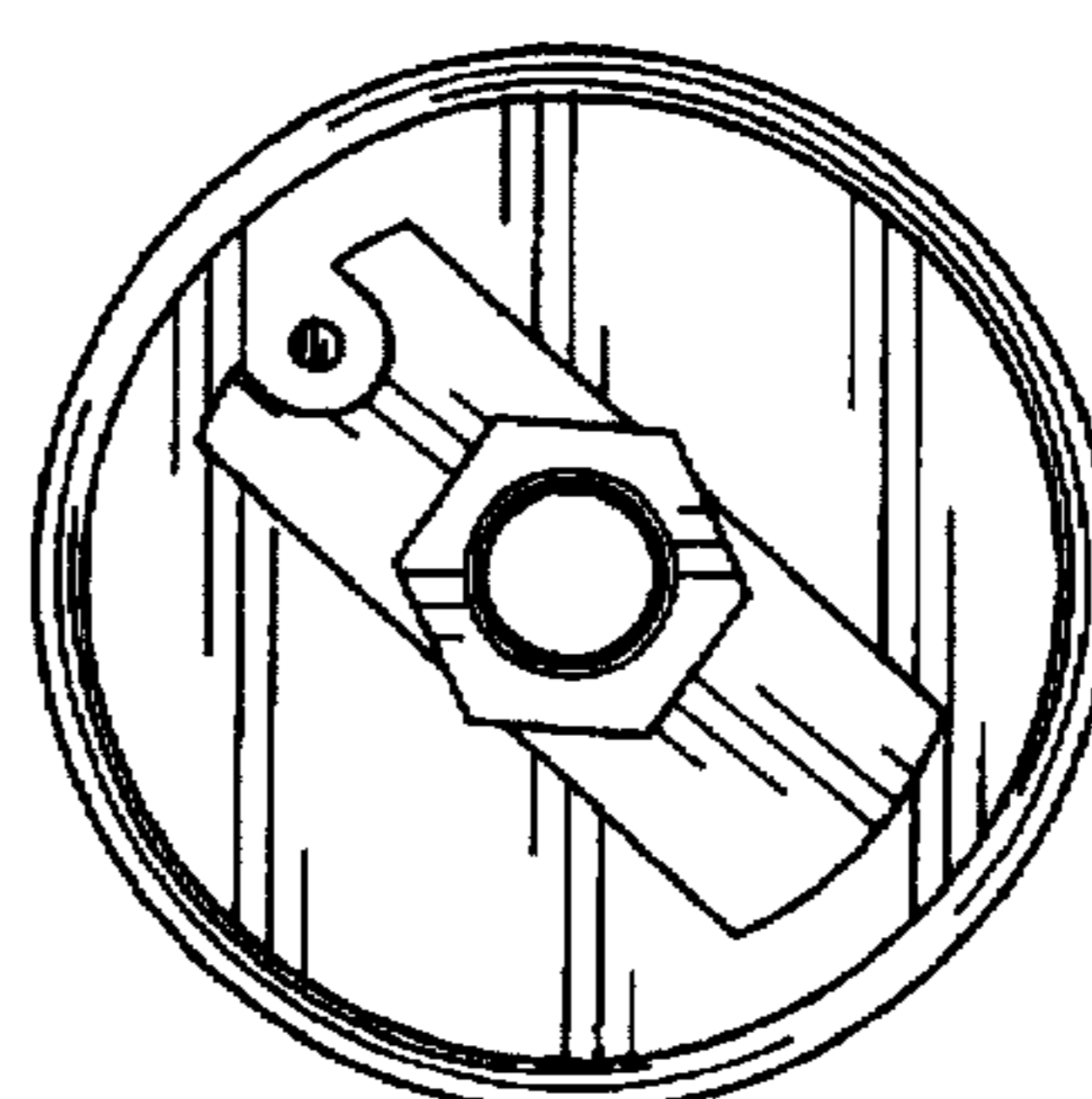

FIG. 5