

US00D386143S

United States Patent [19]
Astaire

[11] **Patent Number: Des. 386,143**

[45] **Date of Patent: **Nov. 11, 1997**

[54] **PAINT SCHEME FOR AN AEROSTAR AIRCRAFT**

Attorney, Agent, or Firm—Brown, Martin, Haller & McClain

[76] **Inventor: Robyn Astaire, 1155 San Ysidro Dr., Beverly Hills, Calif. 90210**

[57] **CLAIM**

[**] **Term: 14 Years**

The ornamental design for a paint scheme for an aerostar aircraft, as shown.

[21] **Appl. No.: 49,524**

DESCRIPTION

[22] **Filed: Jan. 29, 1996**

[51] **LOC (6) Cl 12-07**

FIG. 1 is a perspective view from the right rear of a paint scheme for an aerostar aircraft showing my new design;

[52] **U.S. Cl. D12/345; D12/319**

FIG. 2 is a side perspective view from the left front thereof;

[58] **Field of Search D12/319-345; 244/55, 13**

FIG. 3 is a front view thereof;

[56] **References Cited**

FIG. 4 is a bottom plan view thereof;

U.S. PATENT DOCUMENTS

FIG. 5 is a left side elevational view thereof;

D. 157,353 2/1950 Ebel et al. D12/341

FIG. 6 is an enlargement of the circled portion 6 of FIG. 5 and is typical of all striping on the aircraft; and,

D. 212,512 10/1968 Smith D12/341

D. 352,493 11/1994 Krojer D12/337

FIG. 7 is an enlargement of the encircled portion 7 of FIG. 5 and is typical of the shading of characters of the identification number of the aircraft.

OTHER PUBLICATIONS

Jane's all the World's Aircraft, 1995-96, p. 102, "Reims F 406 Caravan II".

Primary Examiner—Kay H. Chin

1 Claim, 2 Drawing Sheets

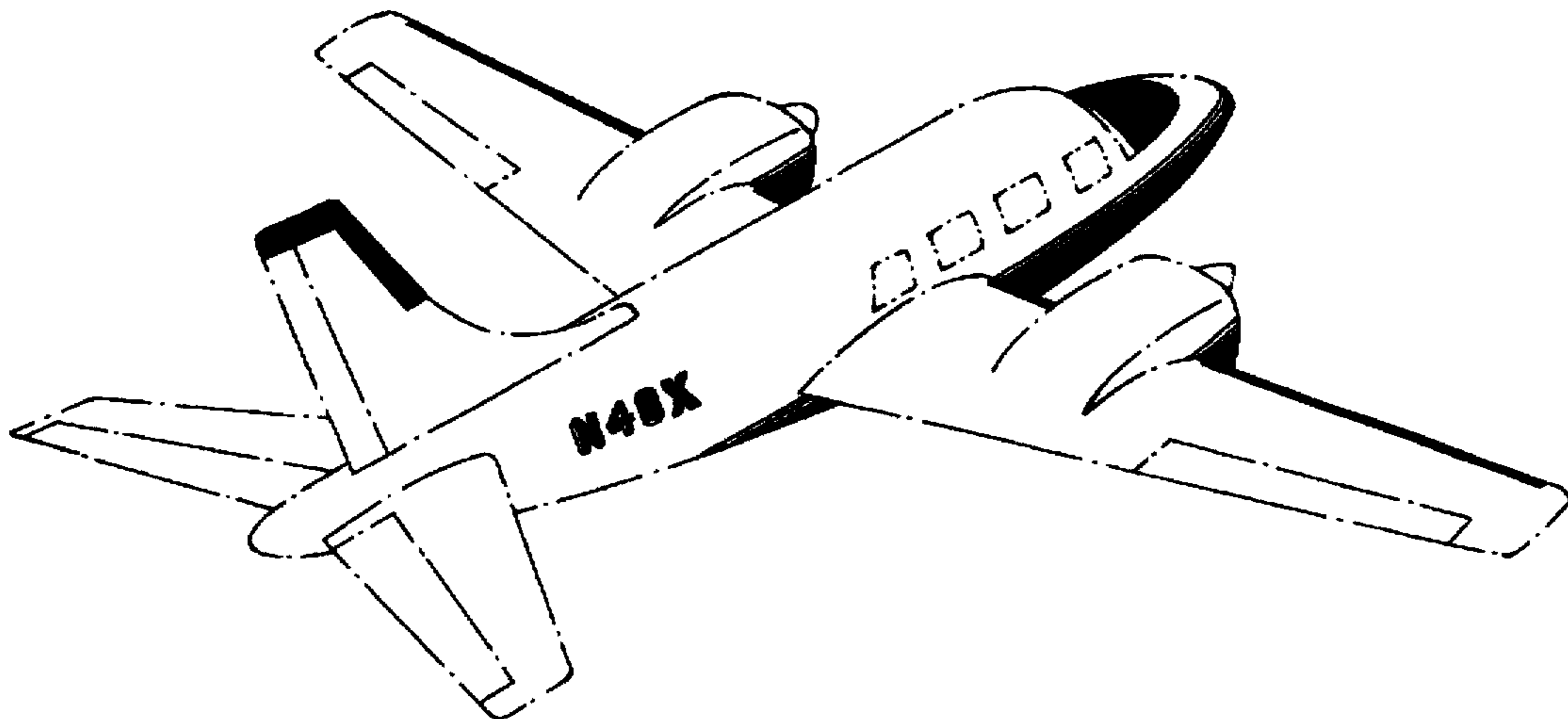

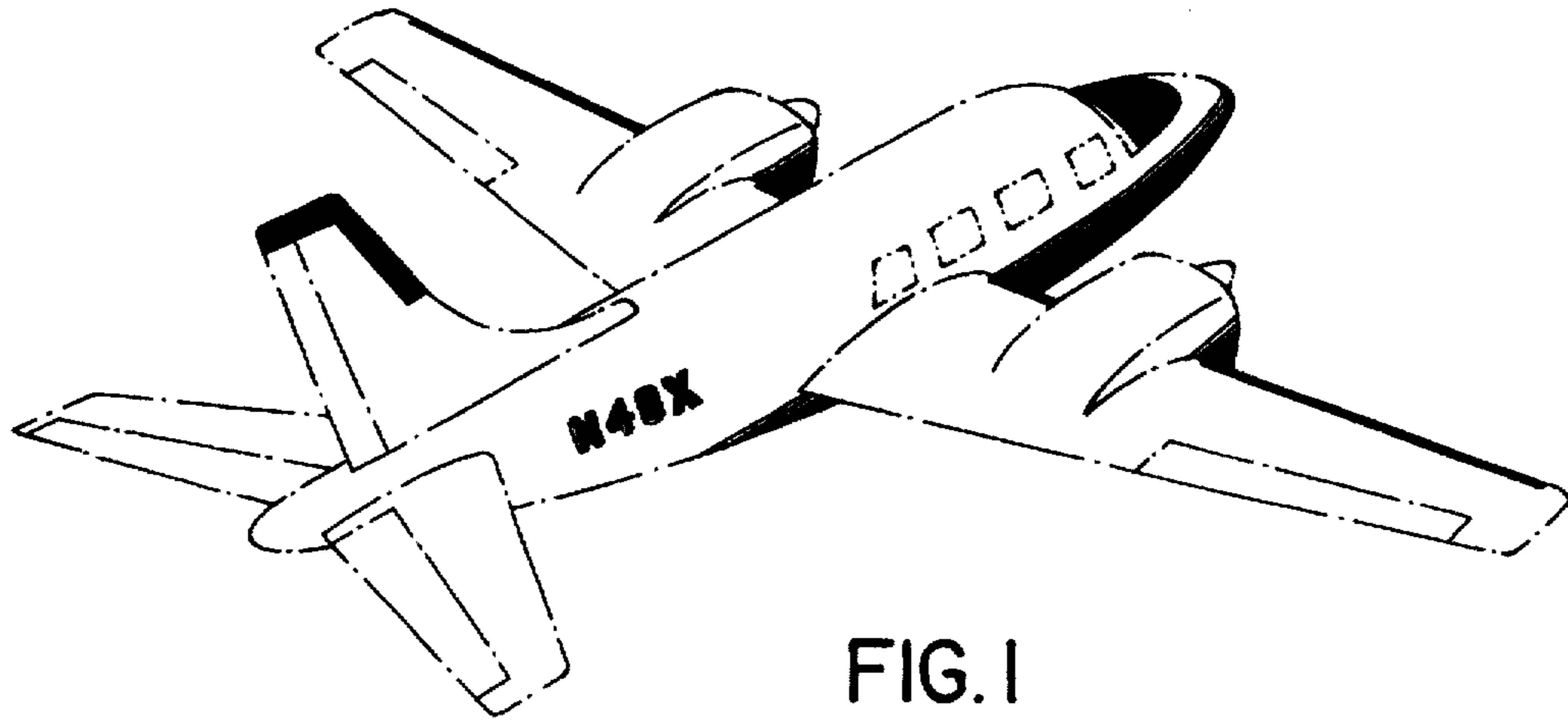

FIG. 1

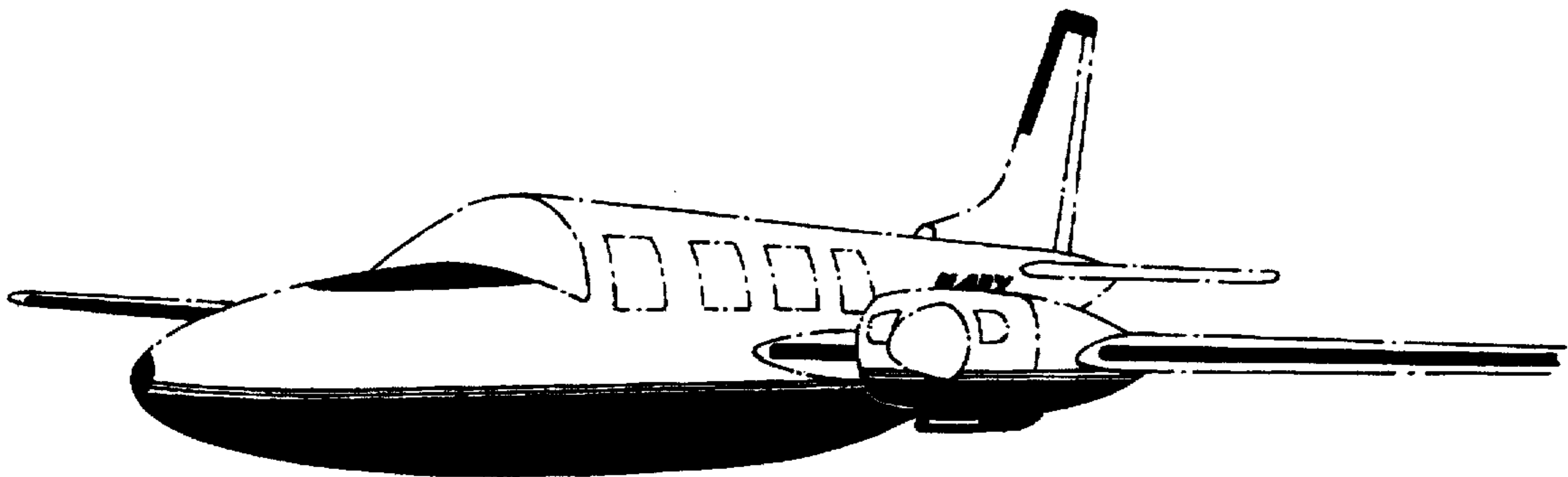

FIG. 2

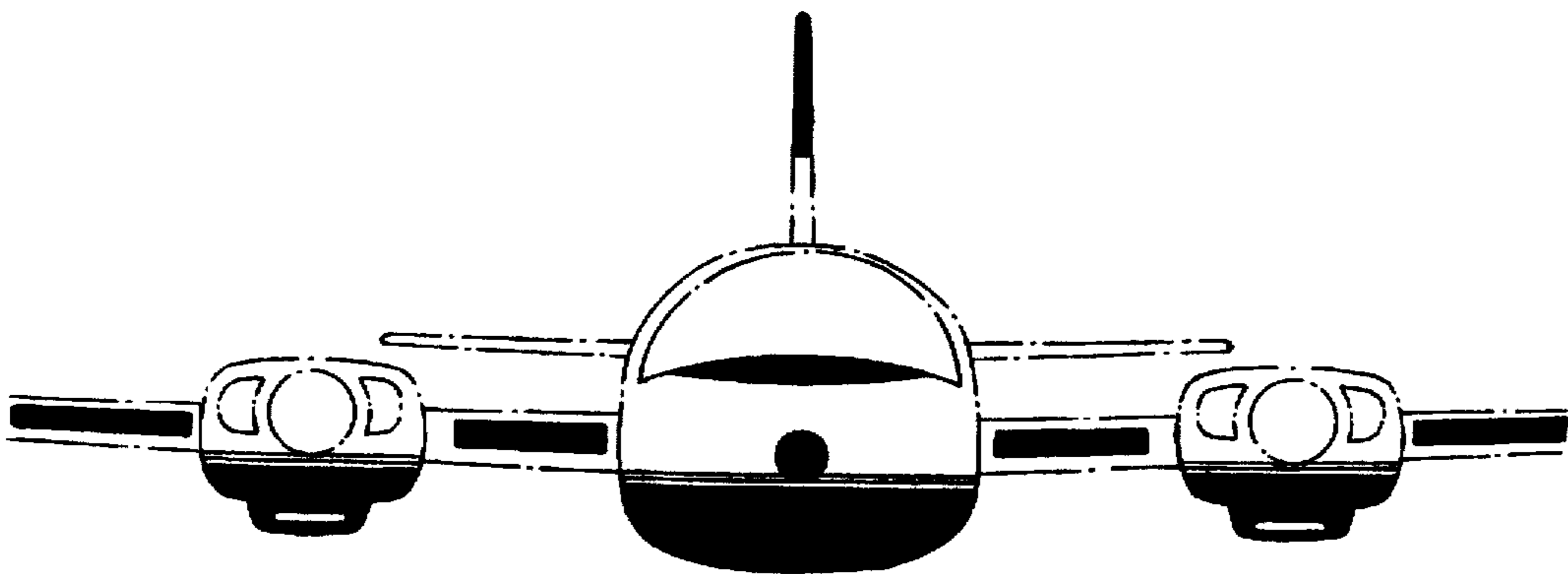

FIG. 3

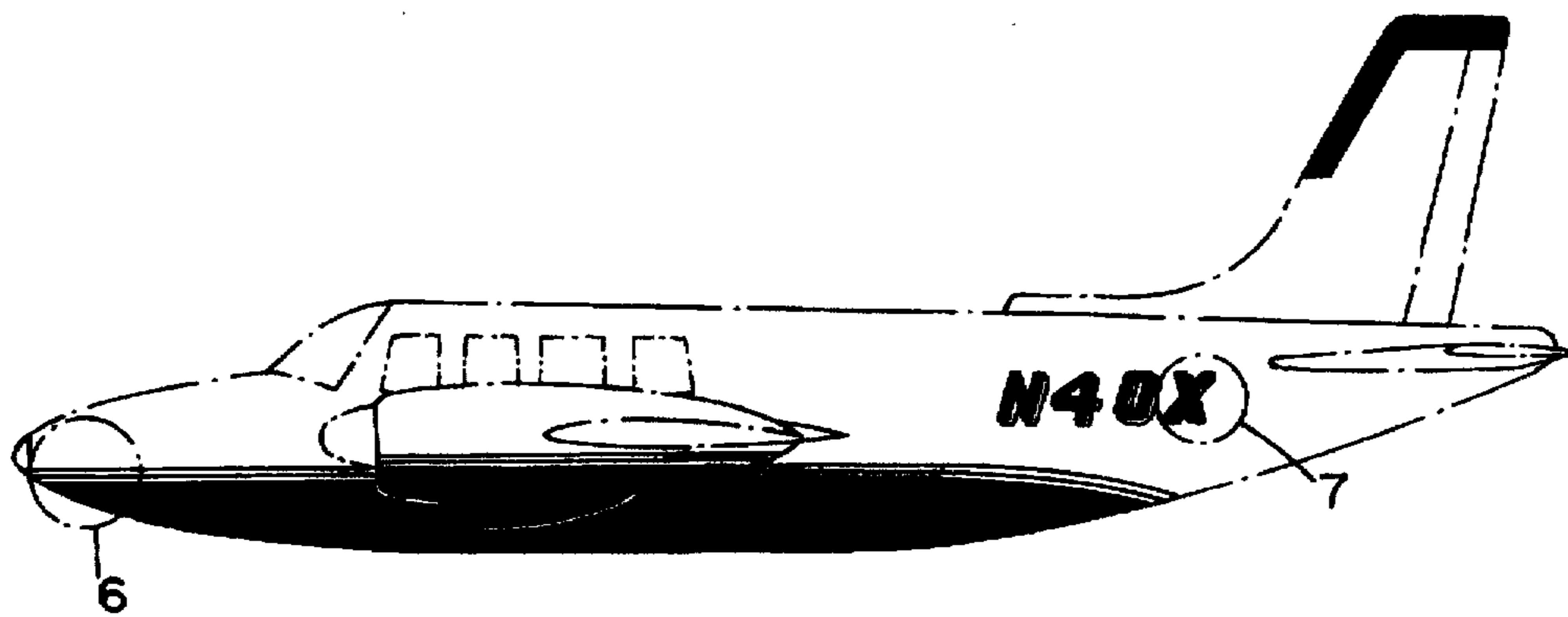
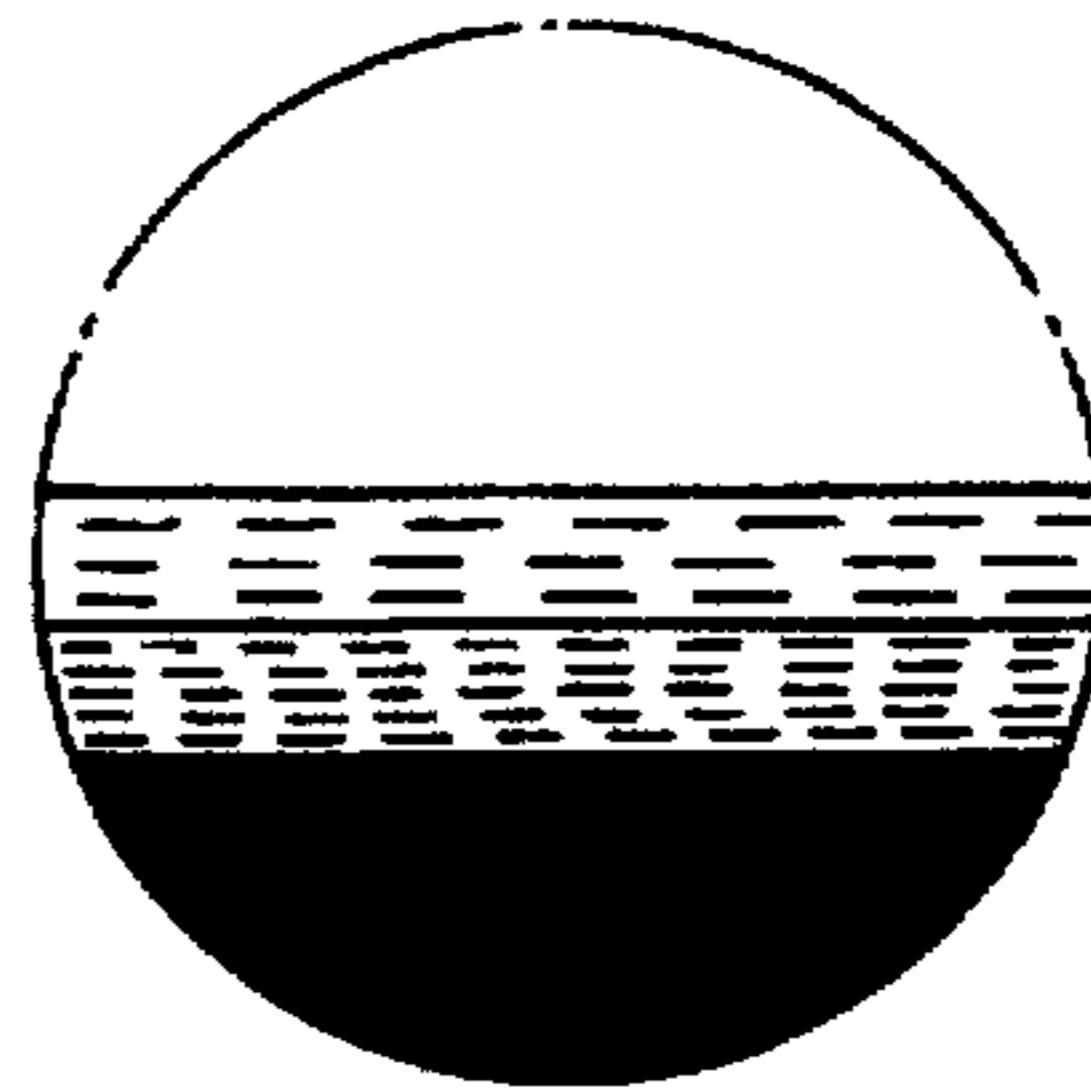
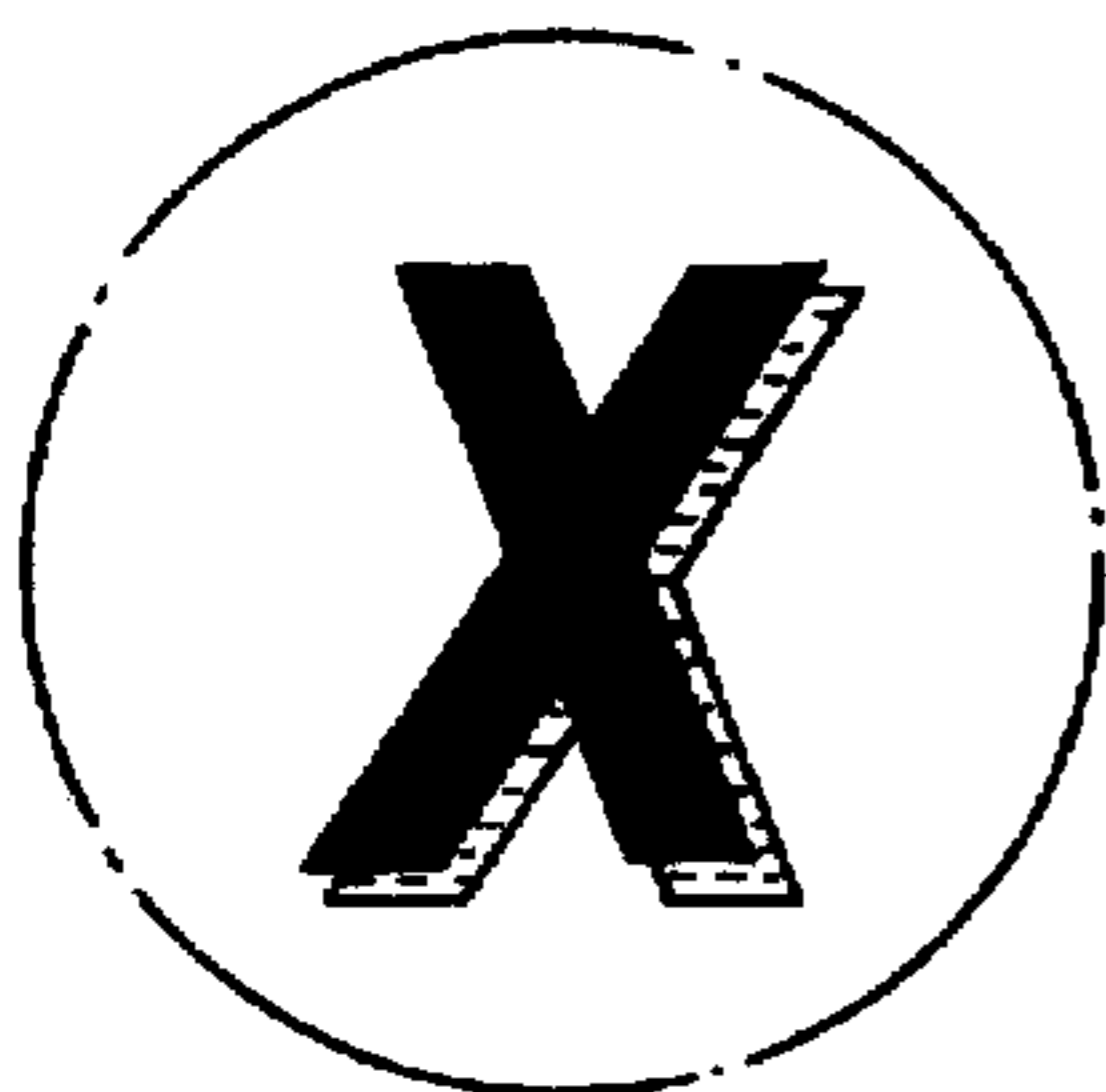
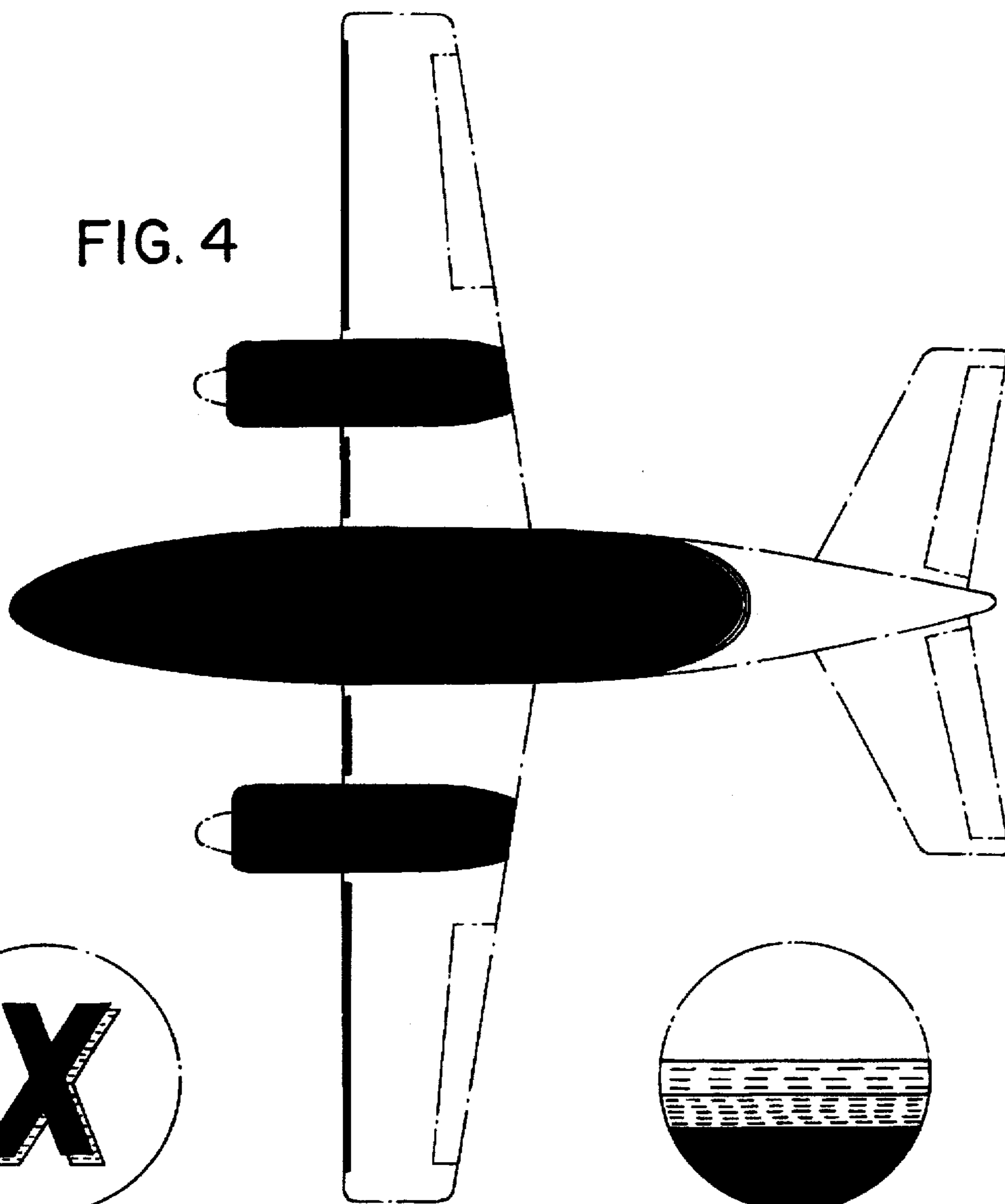

FIG. 5