

US00D385845S

# United States Patent [19]

Wagner

[11] Patent Number: **Des. 385,845**

[45] Date of Patent: **\*\*Nov. 4, 1997**

[54] **VEHICLE TOP**

4,606,573 8/1986 Schneider ..... 296/136  
5,009,938 4/1991 Raj ..... 296/210

[75] Inventor: **John J. Wagner**, Brighton, Mich.

[73] Assignee: **MSX International, Inc.**, Auburn Hills, Mich.

*Primary Examiner*—James M. Gandy  
*Attorney, Agent, or Firm*—Edgar A. Zarins; Malcolm L. Sutherland

[\*\*] Term: **14 Years**

[57] **CLAIM**

[21] Appl. No.: **11,156**

The ornamental design for a vehicle top, as shown and described.

[22] Filed: **Jul. 28, 1993**

**DESCRIPTION**

[51] LOC (6) Cl. .... **12-16**

[52] U.S. Cl. .... **D12/401**

[58] Field of Search ..... D12/156, 401;  
296/107, 136, 210

FIG. 1 is a perspective view of a vehicle top showing my new design in position of use on an automobile which is shown in broken lines for illustrative purposes only and forms no part of the claimed design;  
FIG. 2 is an enlarged top plan view thereof;  
FIG. 3 is an enlarged right side view thereof; the opposite side being a mirror image of the side shown;  
FIG. 4 is an enlarged front elevation view thereof; and  
FIG. 5 is a rear elevation view thereof.

[56] **References Cited**

**U.S. PATENT DOCUMENTS**

2,765,192 10/1956 Blake ..... 296/107  
3,241,877 3/1966 Tate ..... 296/136  
4,516,803 5/1985 Kaltz et al. .... 296/107

**1 Claim, 2 Drawing Sheets**

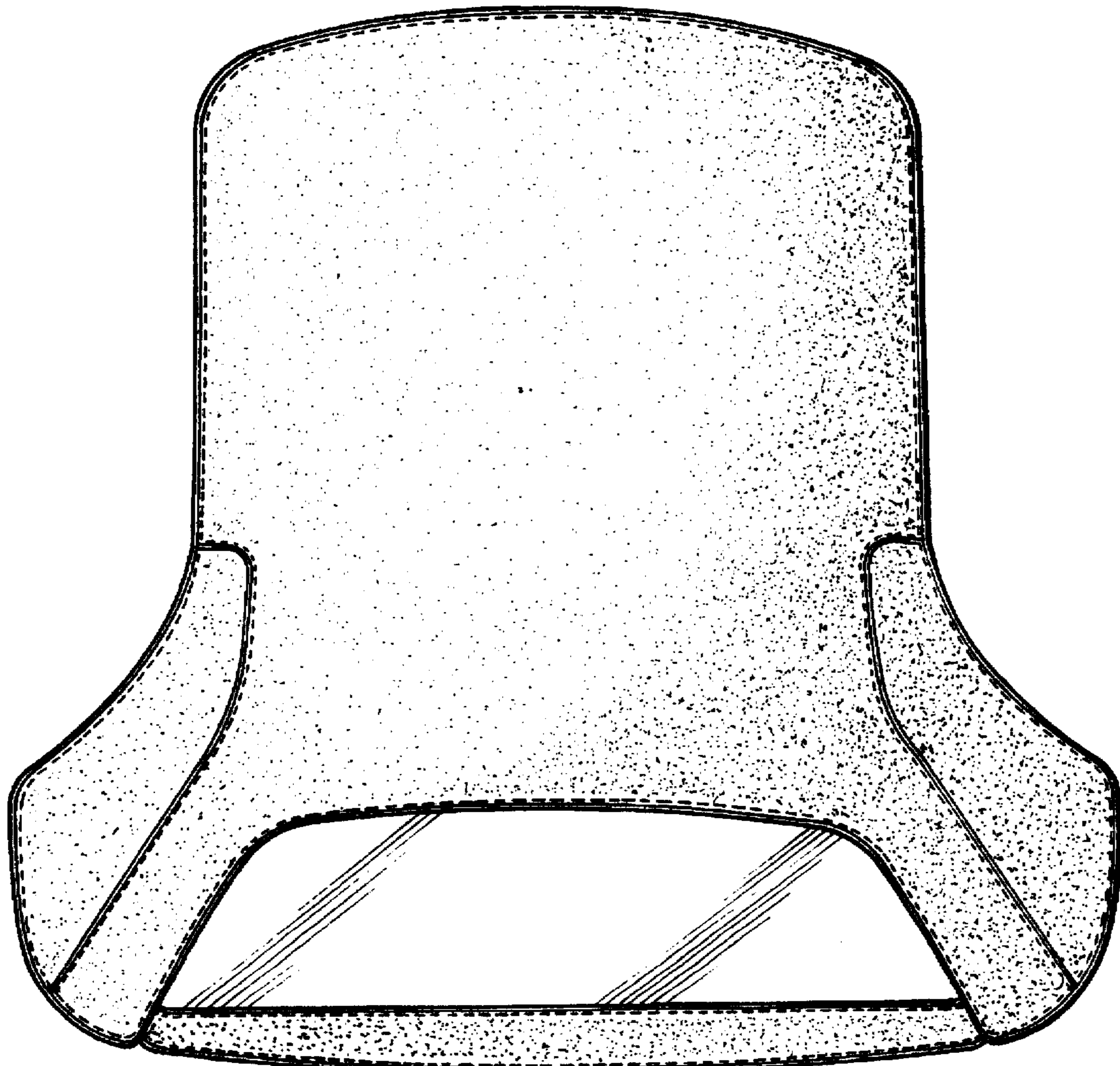

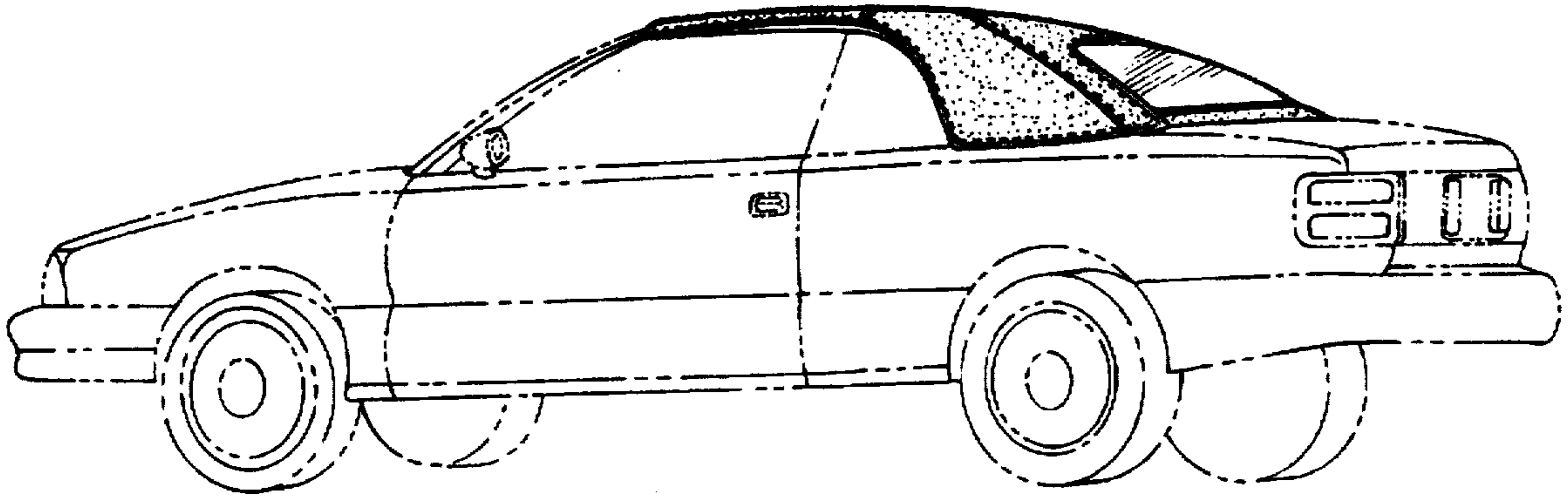
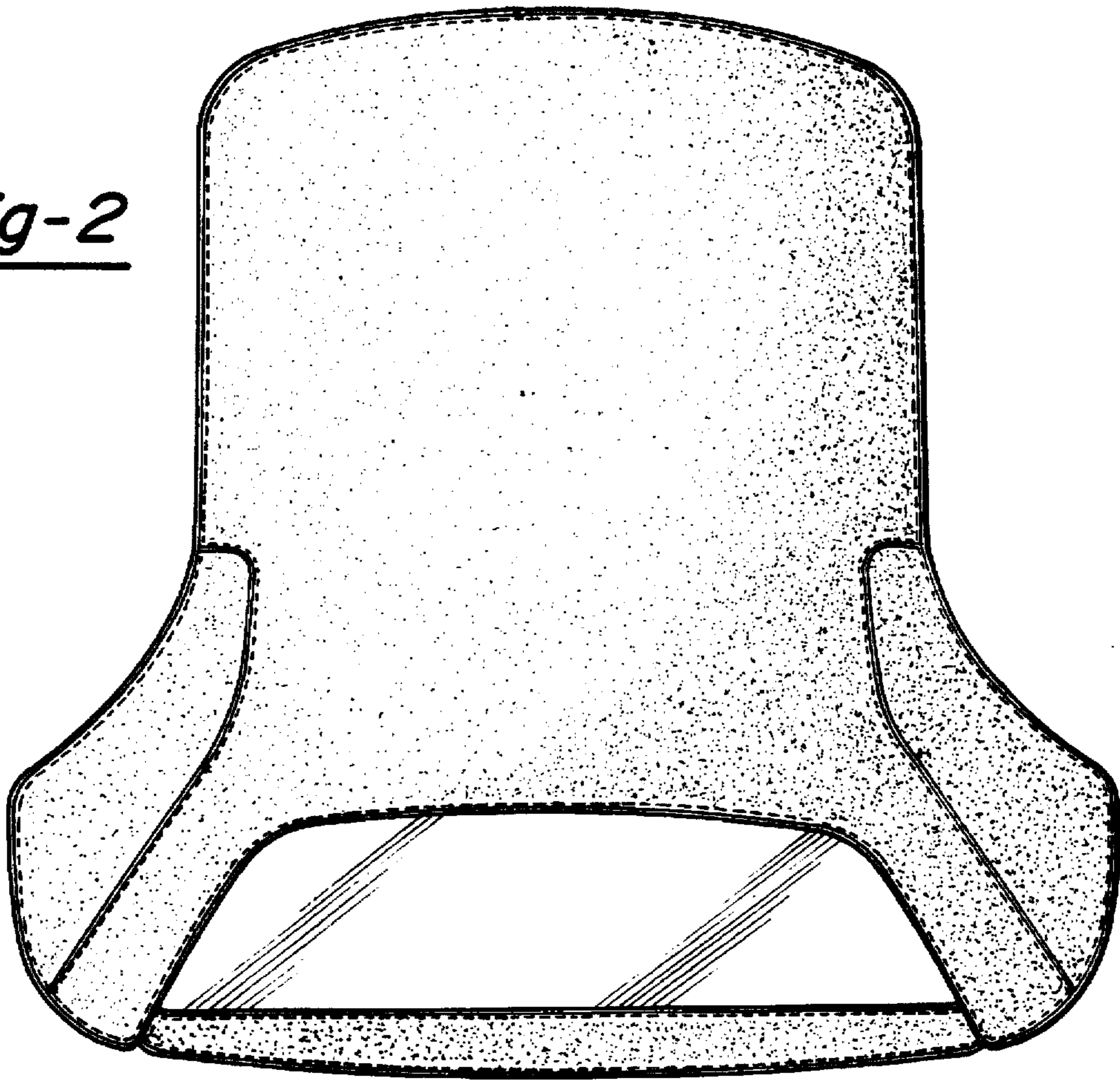

Fig-1

Fig-2



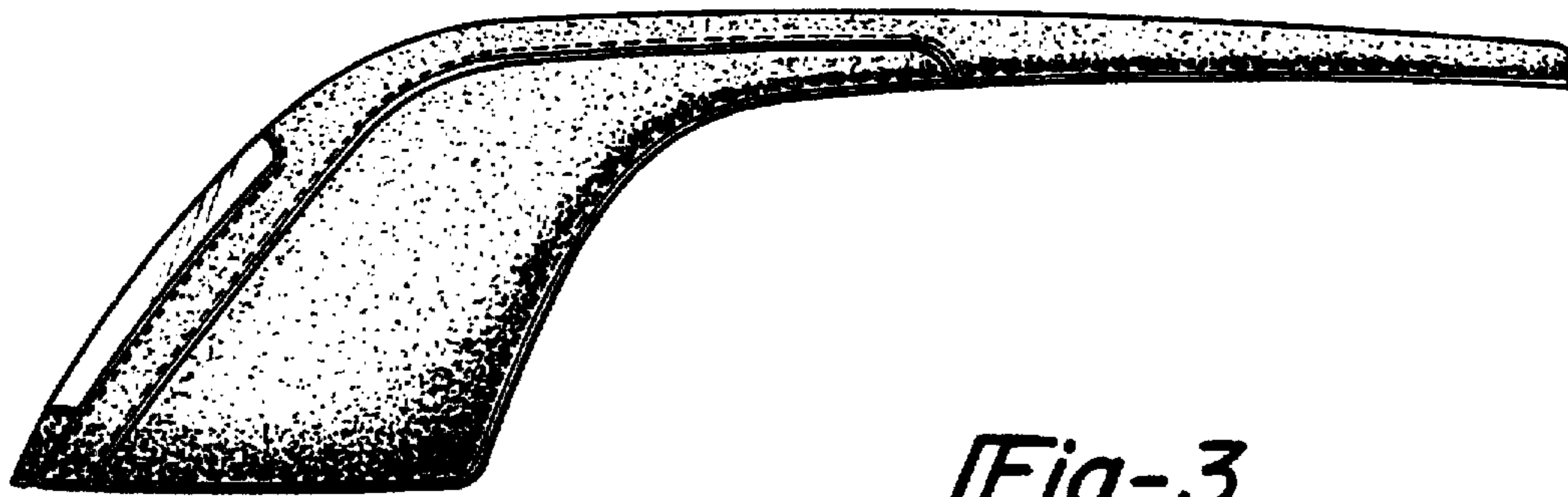

Fig-3

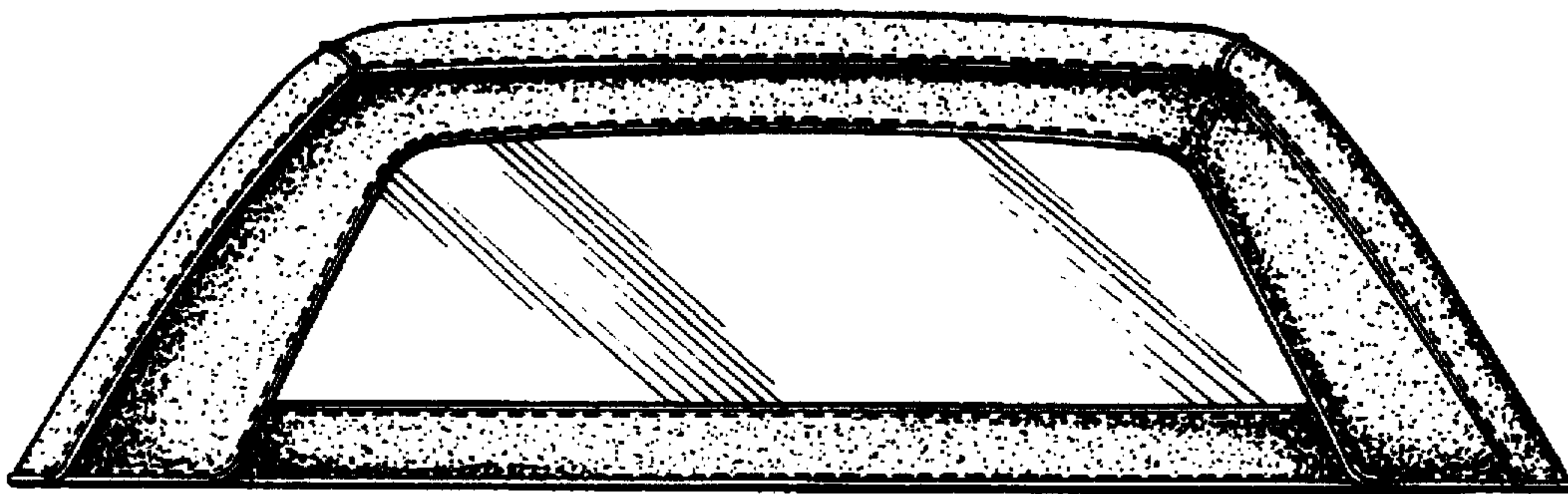

Fig-4

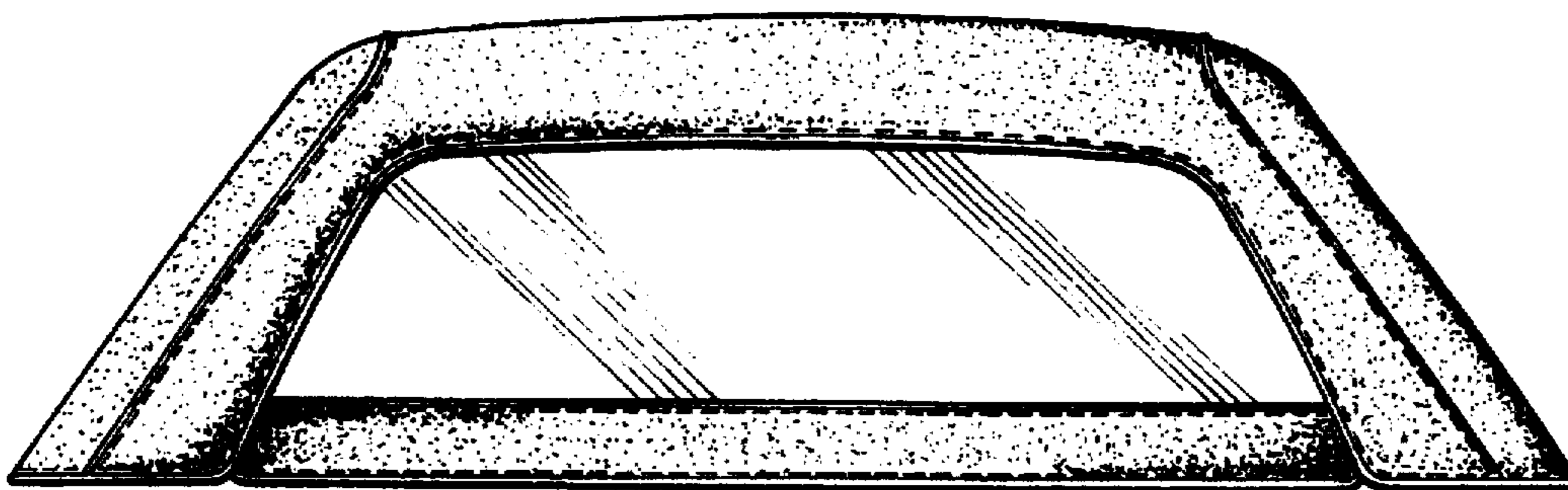

Fig-5