



US00D385828S

United States Patent [19]
Mays

[11] **Patent Number:** **Des. 385,828**
[45] **Date of Patent:** ****Nov. 4, 1997**

[54] **CONVERTIBLE AUTOMOBILE**
[75] **Inventor:** **Jay C. Mays, Woodland Hills, Calif.**
[73] **Assignee:** **Volkswagen AG, Wolfsburg, Germany**
[**] **Term:** **14 Years**
[21] **Appl. No.:** **46,053**
[22] **Filed:** **Nov. 6, 1995**

D. 273,098 3/1984 Ohhashi D12/90
D. 305,998 2/1990 Lagaay D12/92
D. 331,895 12/1992 Panoz et al. D12/92
D. 336,868 6/1993 Dehner et al. D12/92
D. 352,482 11/1994 Cannara et al. D12/90

Primary Examiner—M. H. Tung
Attorney, Agent, or Firm—Watson Cole Stevens Davis,
P.L.L.C.

Related U.S. Application Data

[62] Division of Ser. No. 23,405, May 24, 1994, Pat. No. Des. 367,440.

[51] **LOC (6) Cl.** **12-08**
[52] **U.S. Cl.** **D12/92**
[58] **Field of Search** **D12/82-100; 296/185**

[56] **References Cited**

U.S. PATENT DOCUMENTS

D. 172,249 5/1954 Rivolta D12/90
D. 200,101 1/1965 Smeaton D12/92

[57] **CLAIM**

An ornamental design for convertible automobile, as shown and described.

DESCRIPTION

FIG. 1 is a front perspective view of a convertible automobile;
FIG. 2 is a rear perspective view thereof;
FIG. 3 is a front elevational view thereof;
FIG. 4 is a top plan view thereof, on a reduced scale;
FIG. 5 is a rear elevational view thereof; and,
FIG. 6 is a left side elevational view thereof, the right side is a mirror image, on a reduced scale.

1 Claim, 6 Drawing Sheets

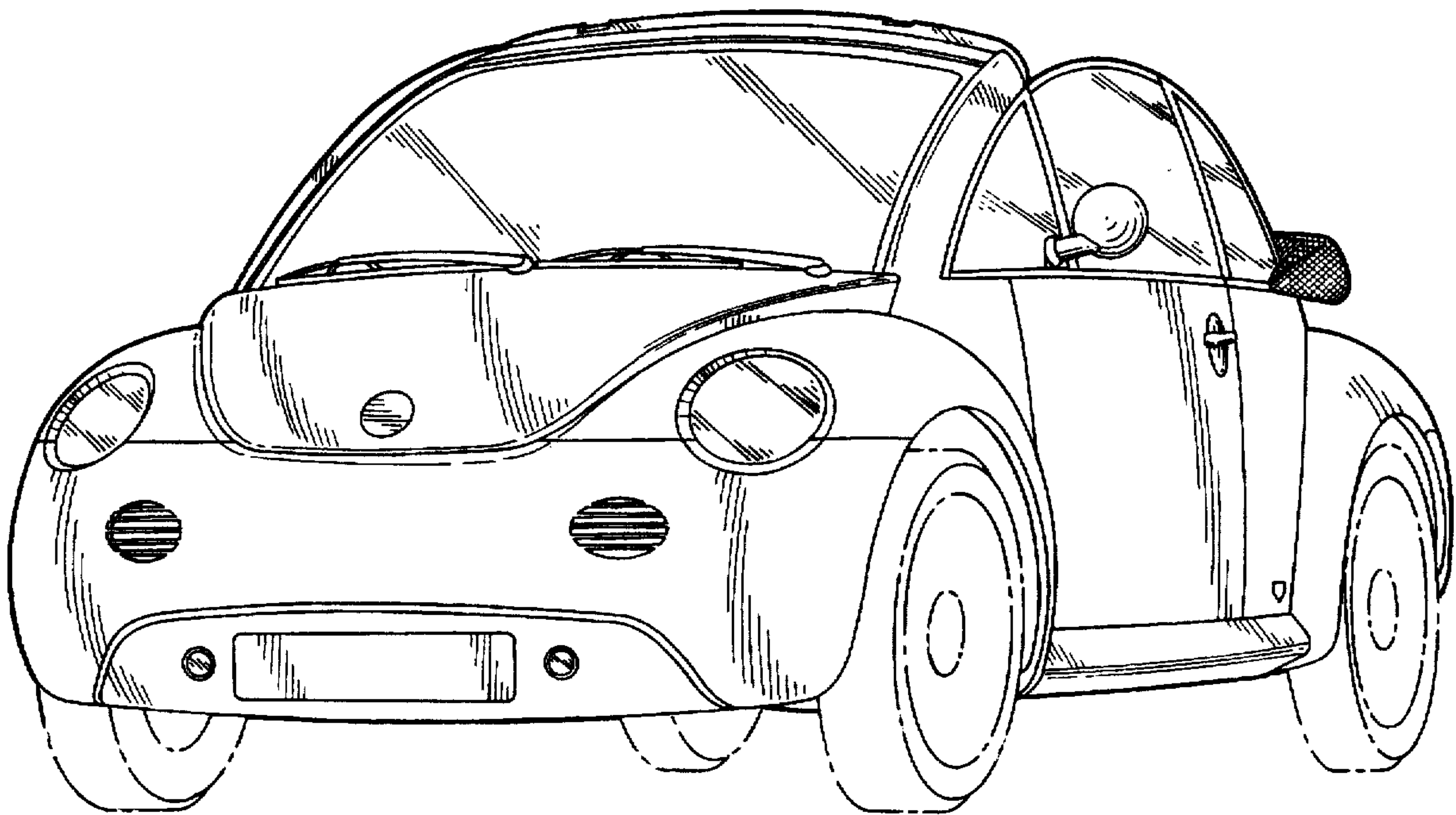

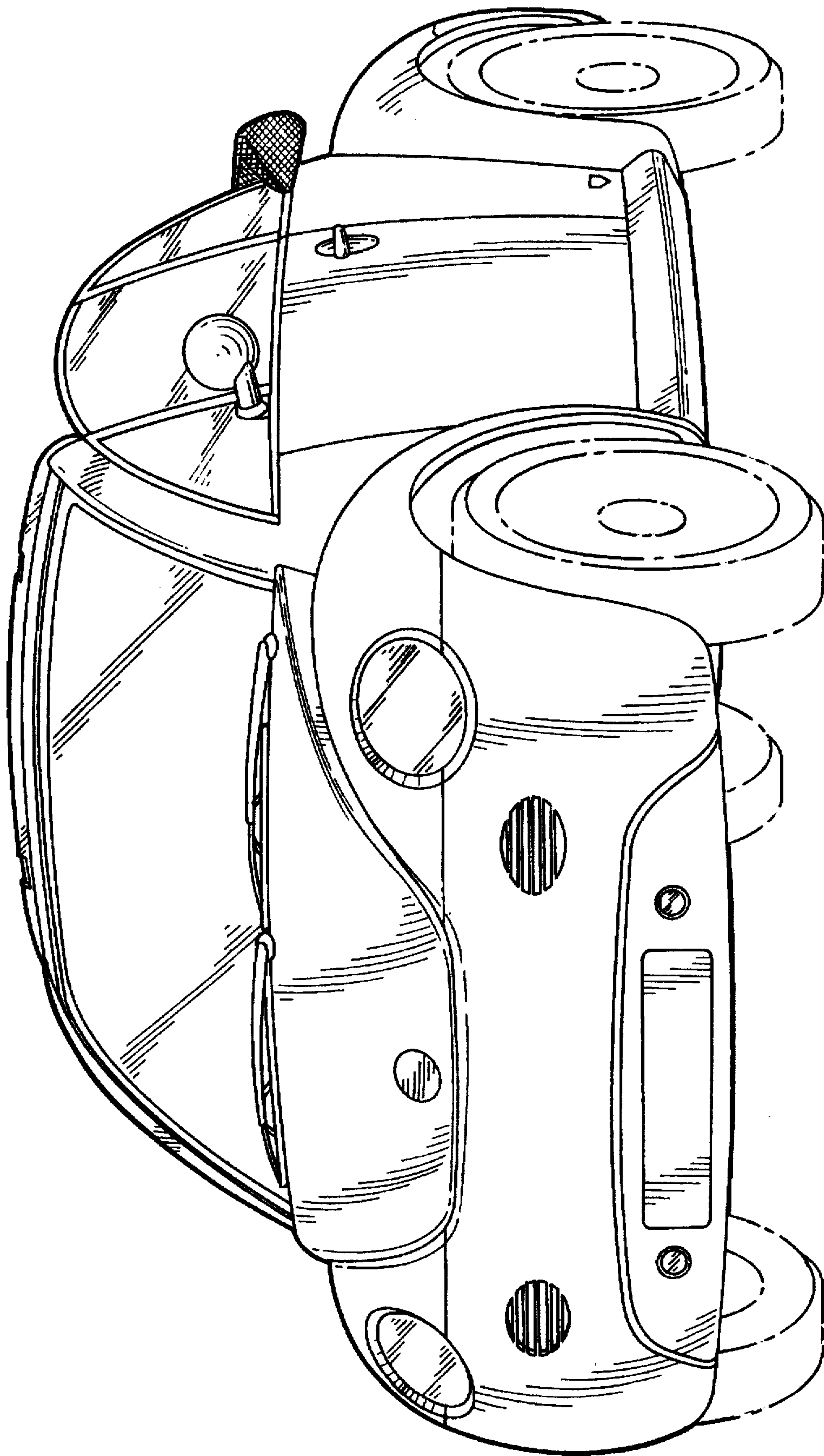

FIG. 1

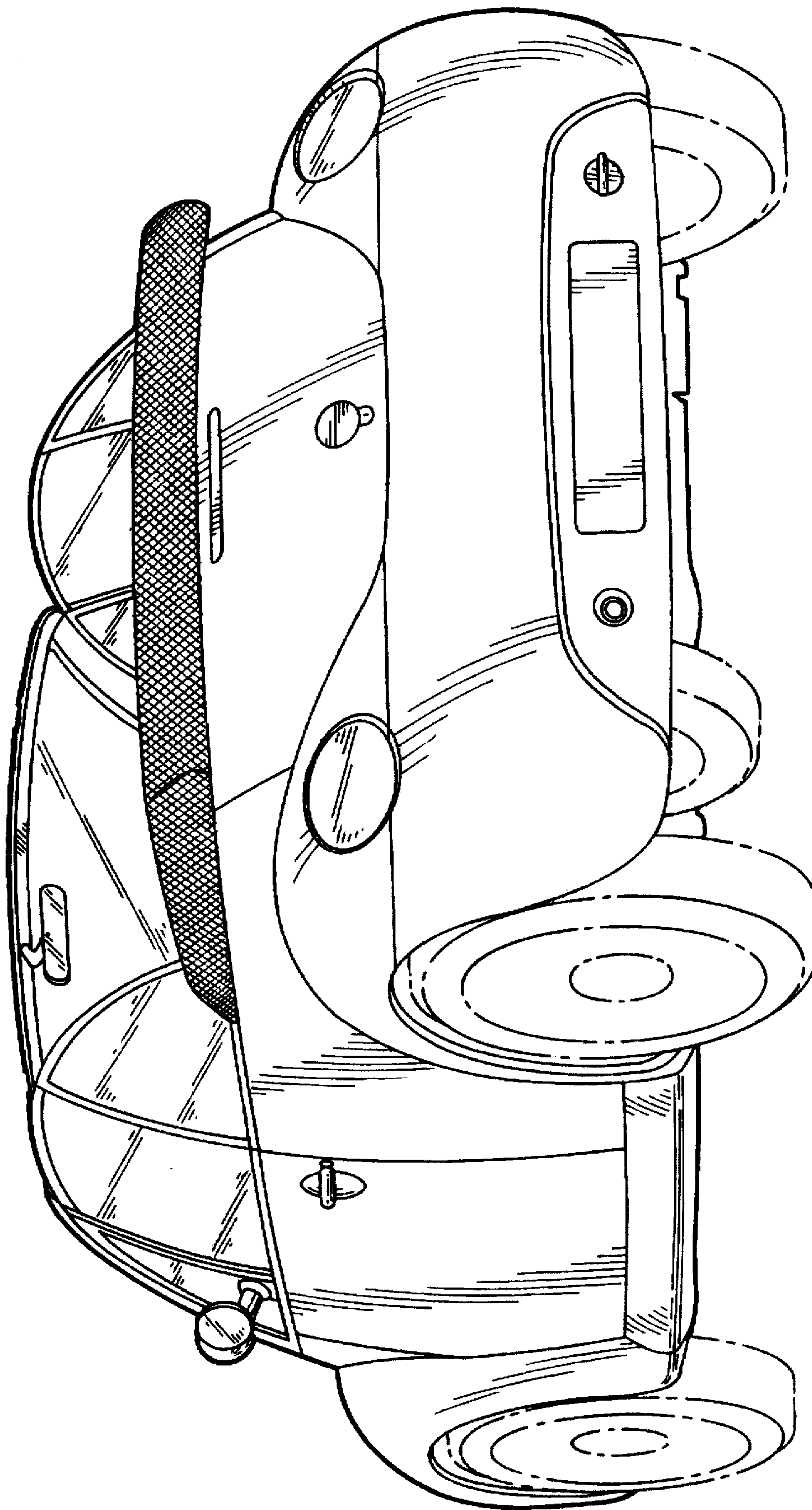

FIG. 2

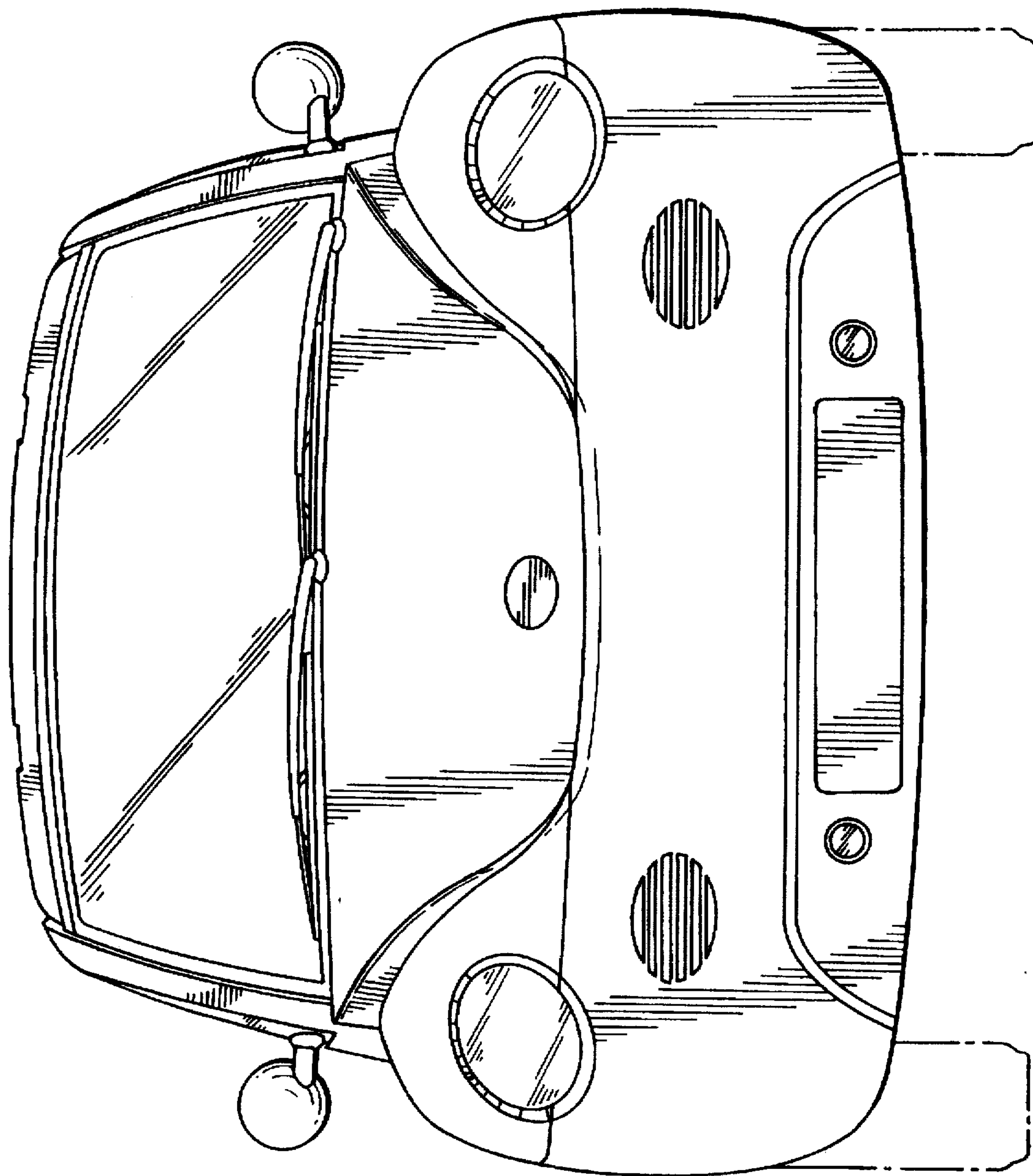

FIG. 3

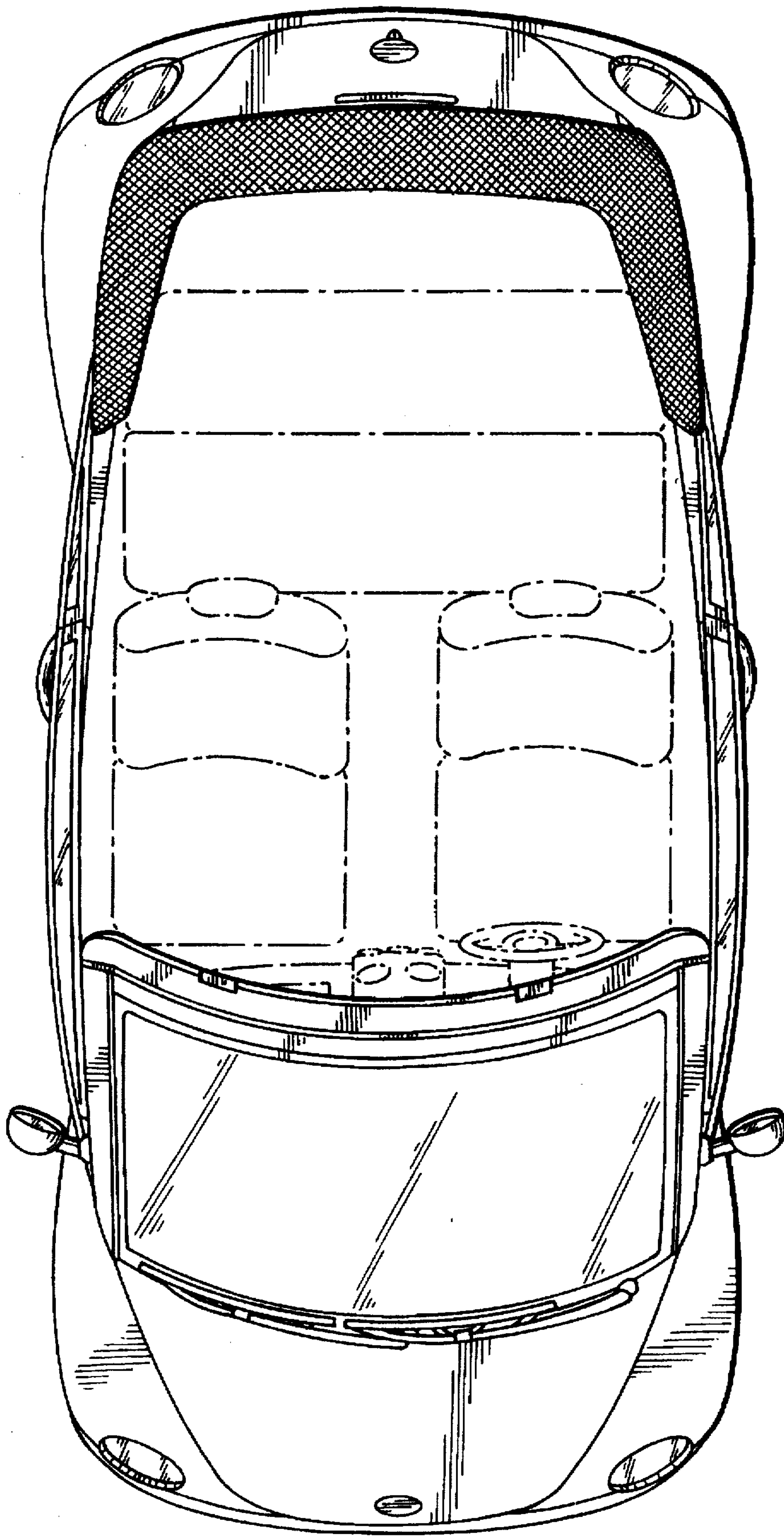

FIG. 4

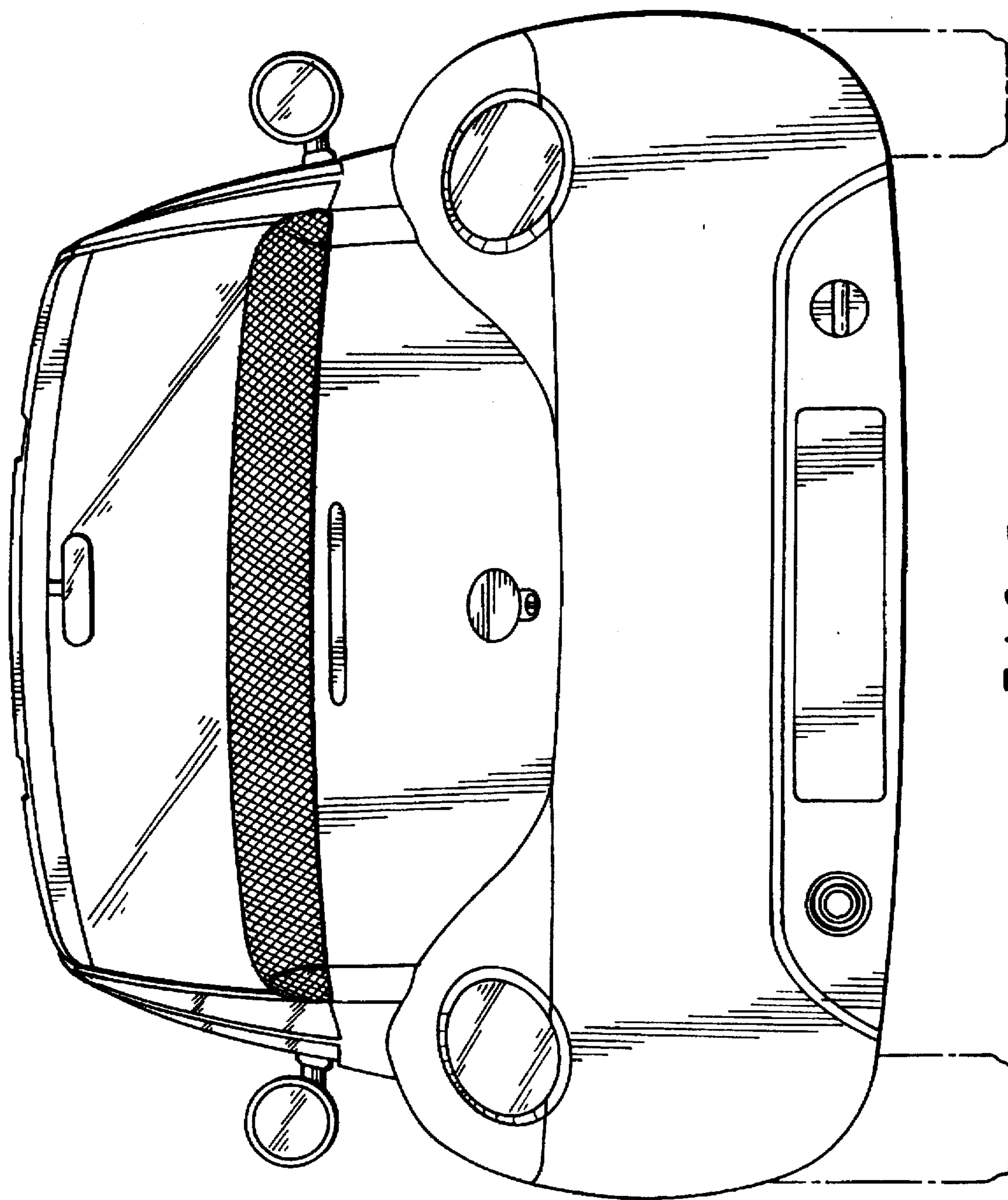

FIG. 5

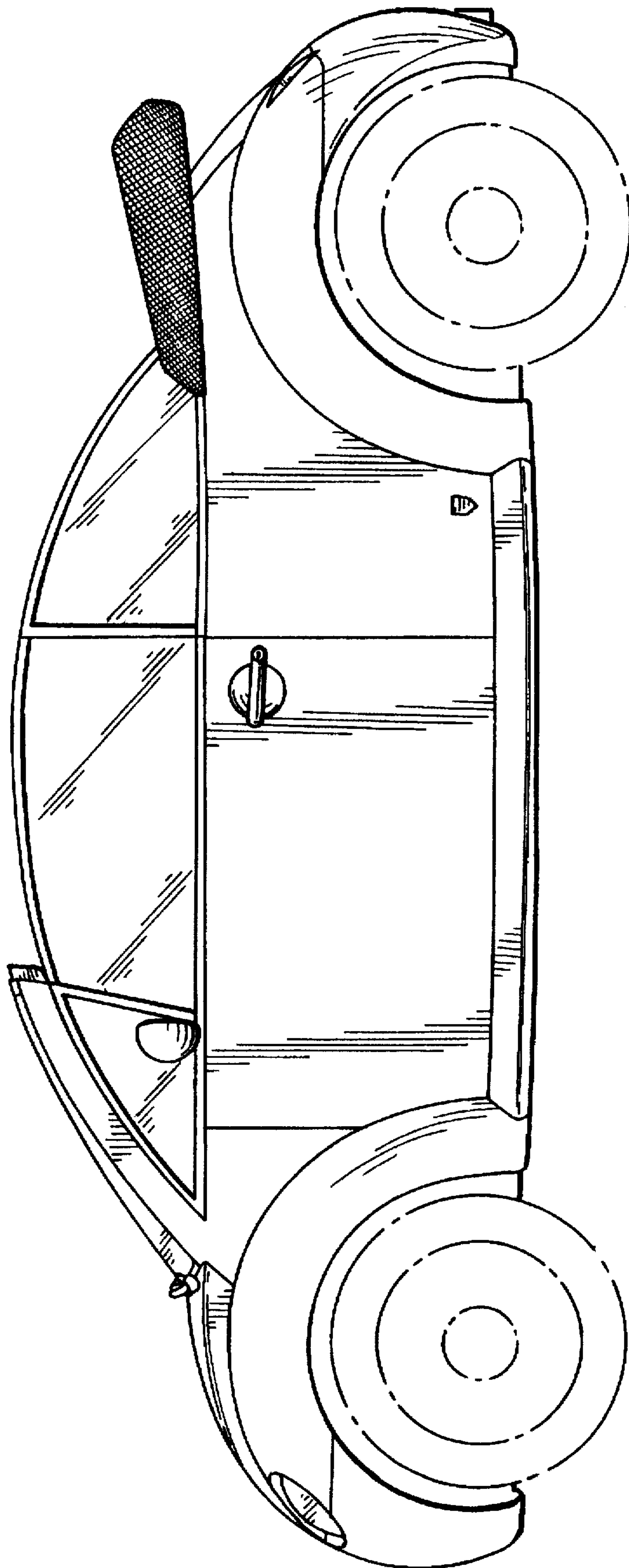

FIG. 6