



US00D385309S

United States Patent [19]

Riley et al.

[11] Patent Number: Des. 385,309

[45] Date of Patent: **Oct. 21, 1997

[54] COMPUTER GAME PLAYER ACCESSORY HOUSING

D. 362,870 10/1995 Oikawa D21/13
5,161,803 11/1992 Ohara 273/434 X
5,213,327 5/1993 Kitaue 273/148 B

[75] Inventors: Raymond W. Riley, Santa Cruz; David W. Laituri, Palo Alto, both of Calif.

OTHER PUBLICATIONS

Hong Kong Enterprise, Oct. 1994, p. 137.

[73] Assignee: Apple Computer, Inc., Cupertino, Calif.

Primary Examiner—Prabhakar G. Deshmukh
Attorney, Agent, or Firm—David J. Larwood

[**] Term: 14 Years

[57] CLAIM

[21] Appl. No.: 36,984

The ornamental design for a computer game player accessory housing, as shown and described.

[22] Filed: Mar. 31, 1995

DESCRIPTION

Related U.S. Application Data

[63] Continuation-in-part of Ser. No. 36,881, Mar. 29, 1995, abandoned.

FIG. 1 is a front elevational view of a computer game player accessory housing showing our new design;
FIG. 2 is a left side elevational view of FIG. 1;
FIG. 3 is a top plan view of FIG. 1;
FIG. 4 is a rear elevational view of FIG. 1;
FIG. 5 is a right side elevational view of FIG. 1;
FIG. 6 is a bottom plan view of FIG. 1;
FIG. 7 is a front, top, left side perspective view of FIG. 1;
FIG. 8 is a rear, bottom, right side perspective view of FIG. 1; and,
FIG. 9 is a front elevational view similar to FIG. 1; with an environmental feature shown in broken lines; Said broken lines showing of a computer game housing is for illustrative purpose only and forms no part of the claim.

[51] LOC (6) Cl. 21-01

[52] U.S. Cl. D21/48

[58] Field of Search D21/1, 13, 48;
273/148 B, 433-438, DIG. 28; D14/124,
125, 114, 217

[56] References Cited

U.S. PATENT DOCUMENTS

D. 299,726 2/1989 Yukawa D21/48 X
D. 337,568 7/1993 Ellis D14/121
D. 349,520 8/1994 Iwakami D21/13
D. 362,692 9/1995 Rissman et al. D21/13

1 Claim, 3 Drawing Sheets

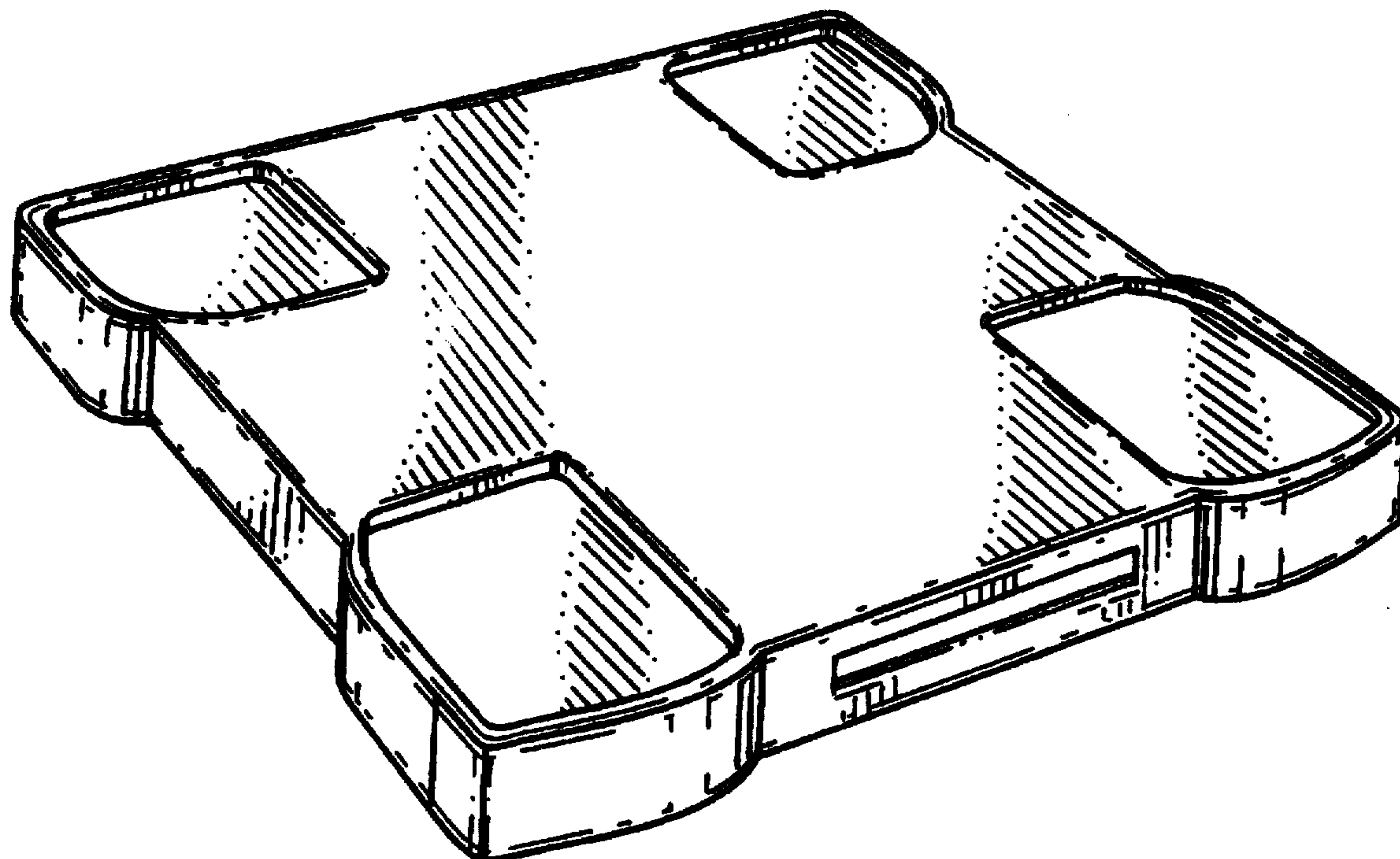

FIGURE 2

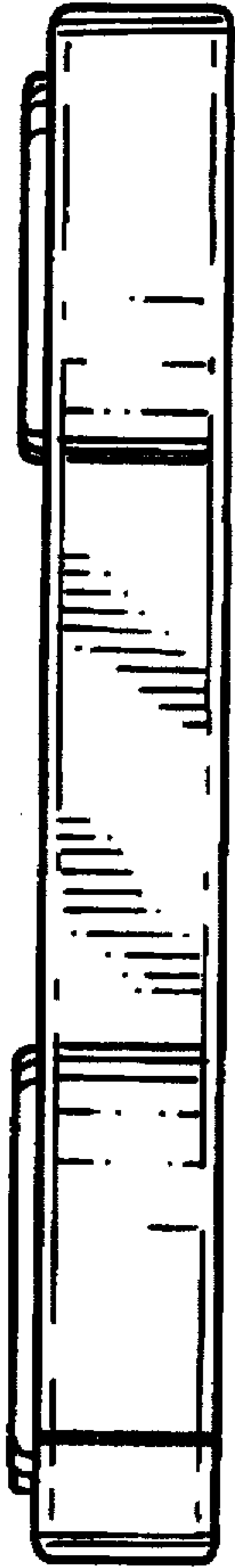

FIGURE 3

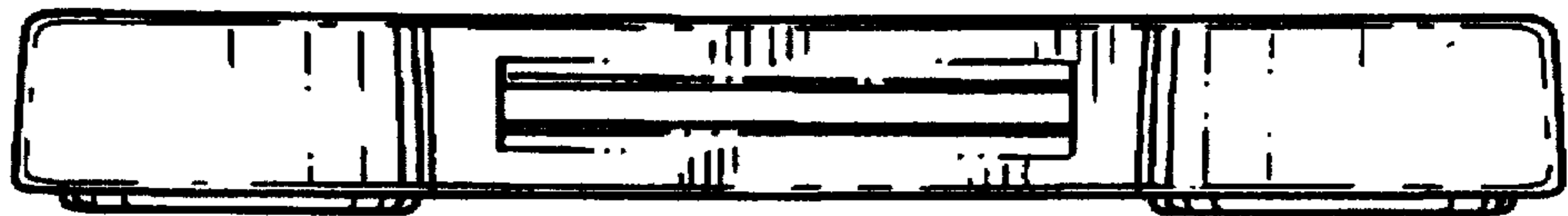
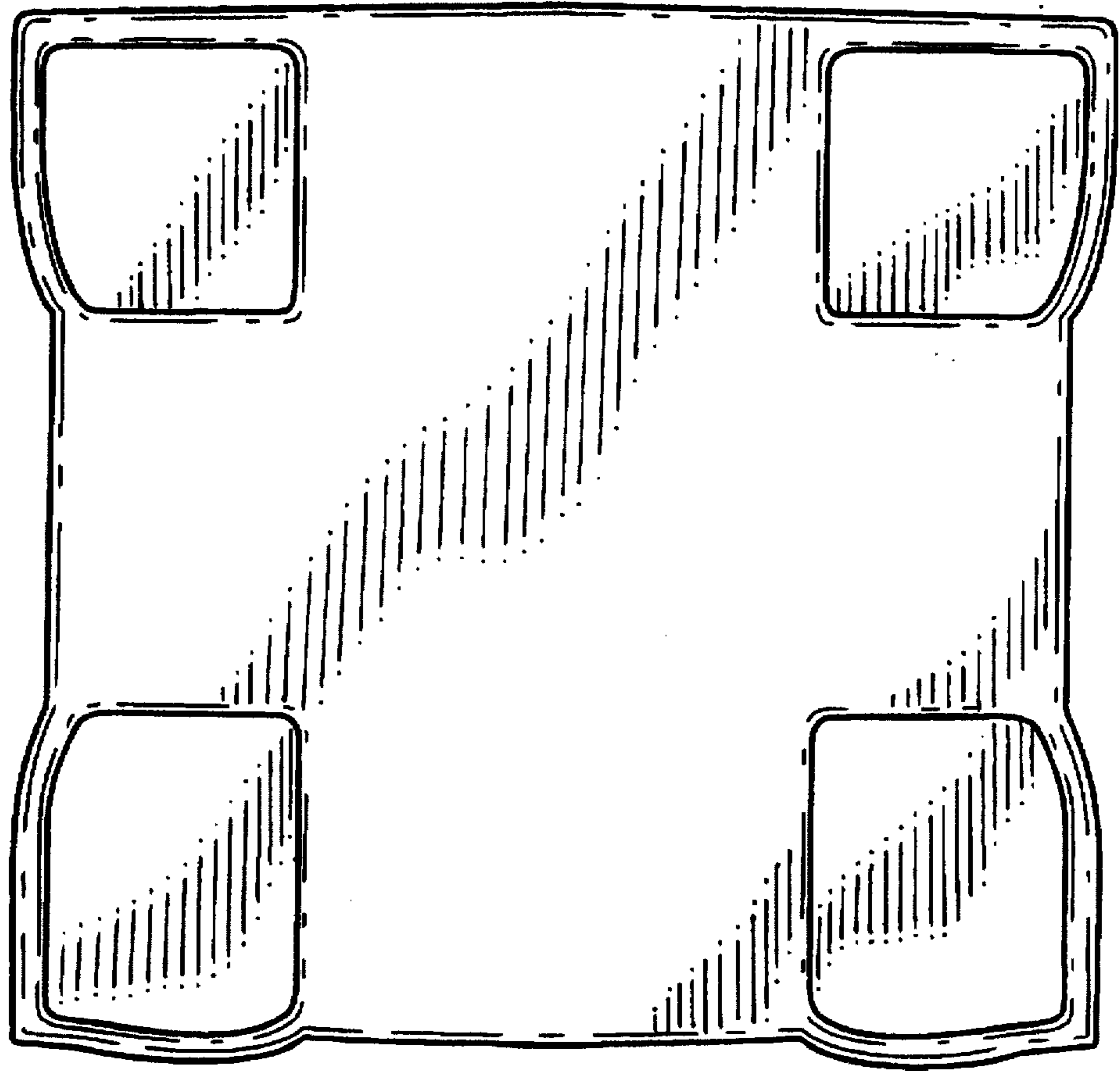

FIGURE 1

FIGURE 4

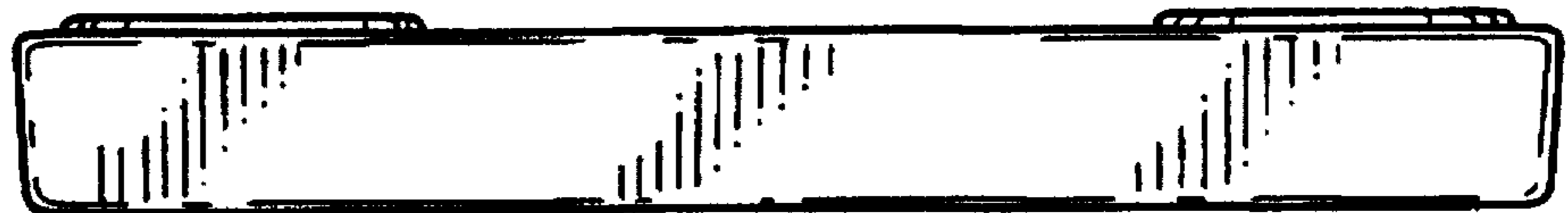

FIGURE 5

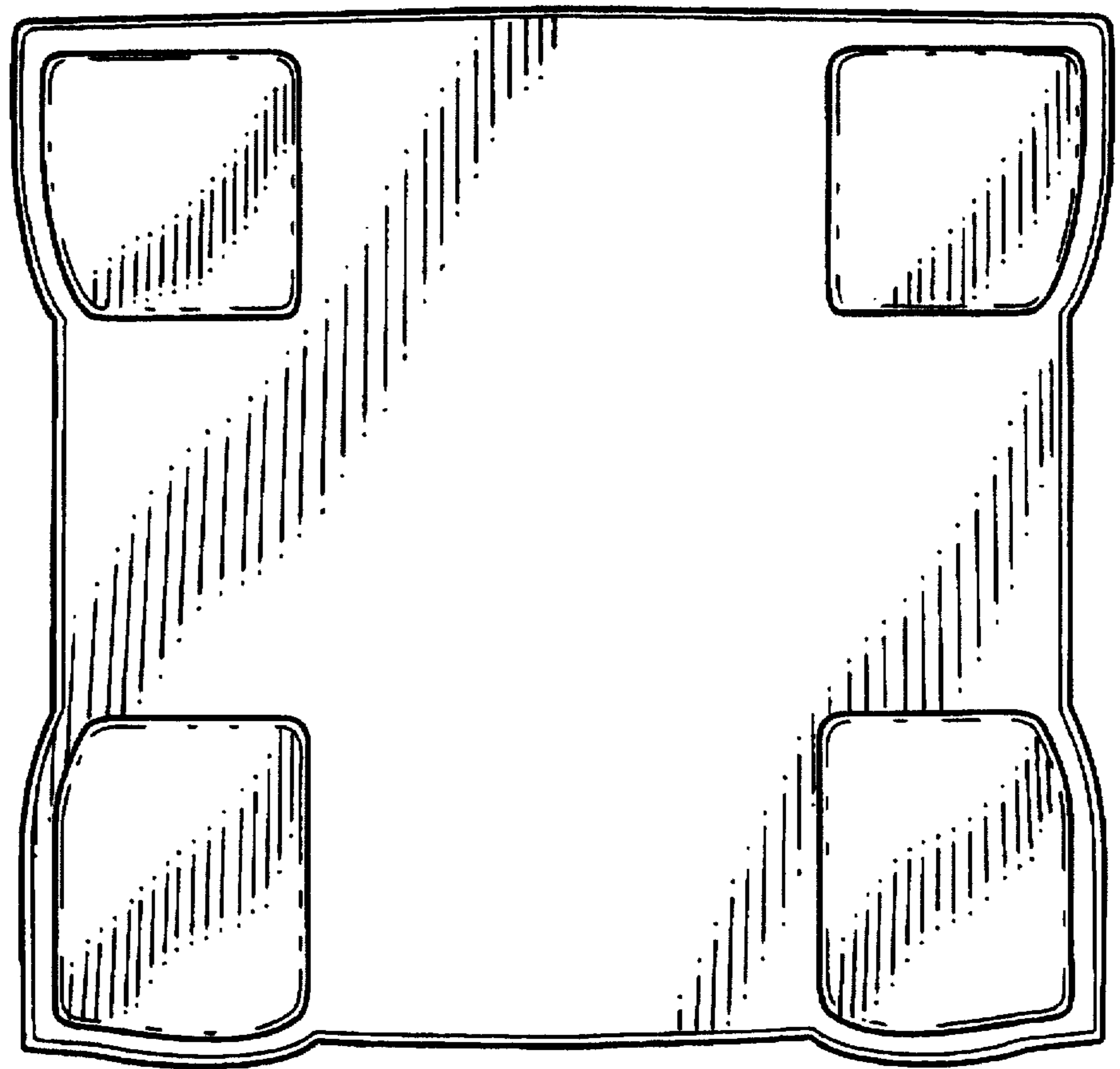
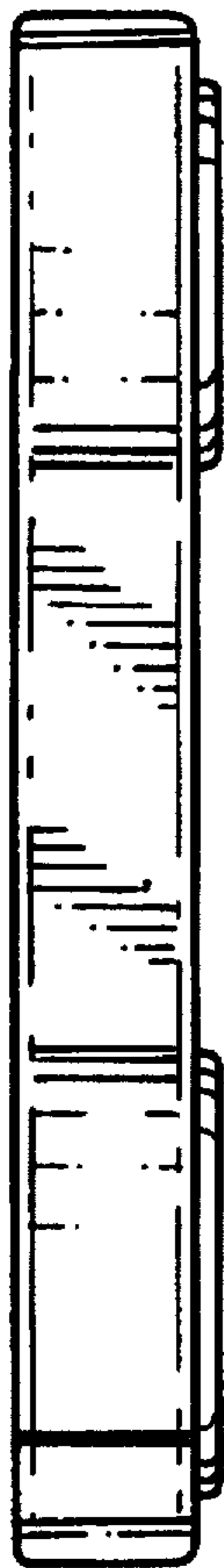

FIGURE 6

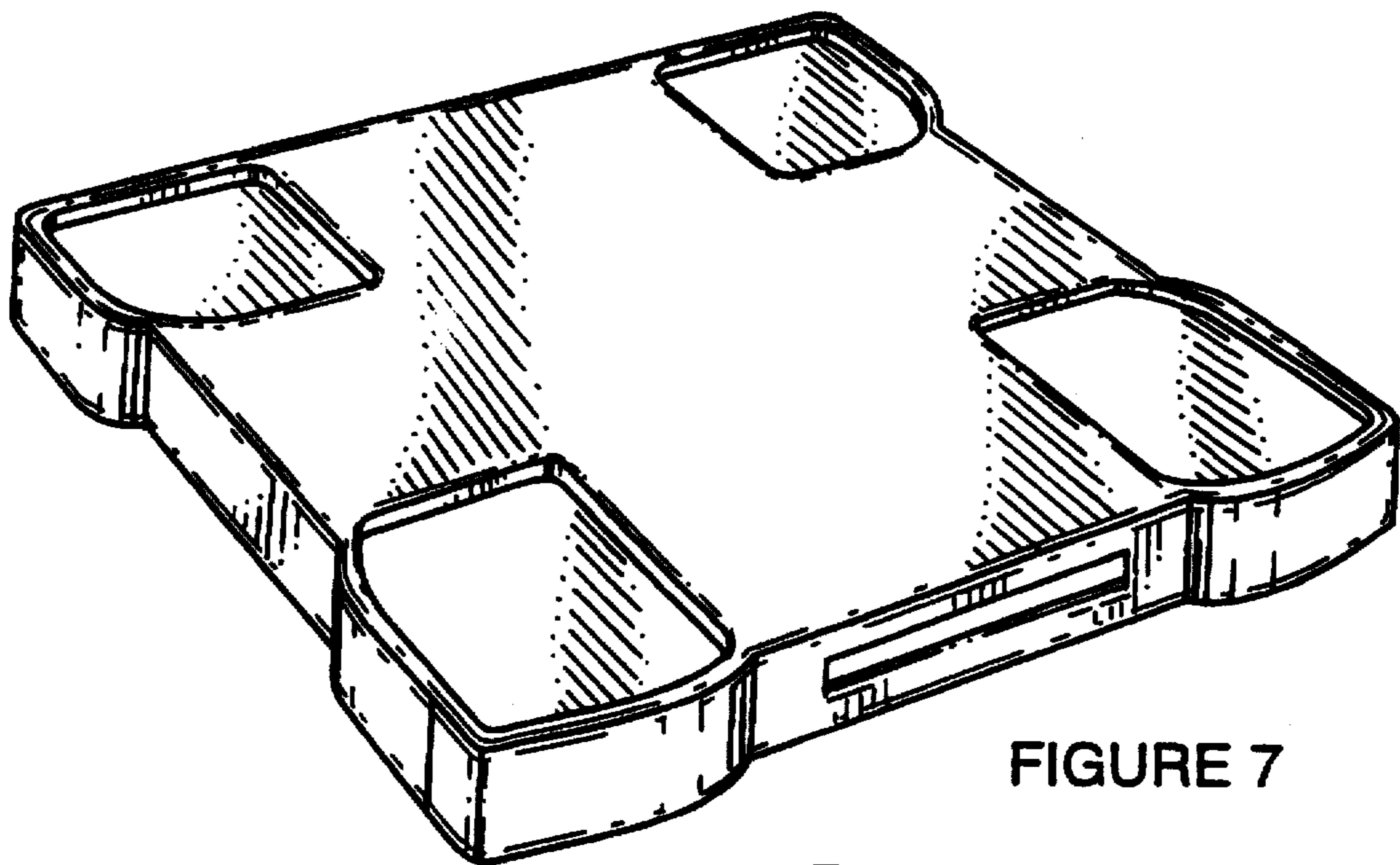

FIGURE 7

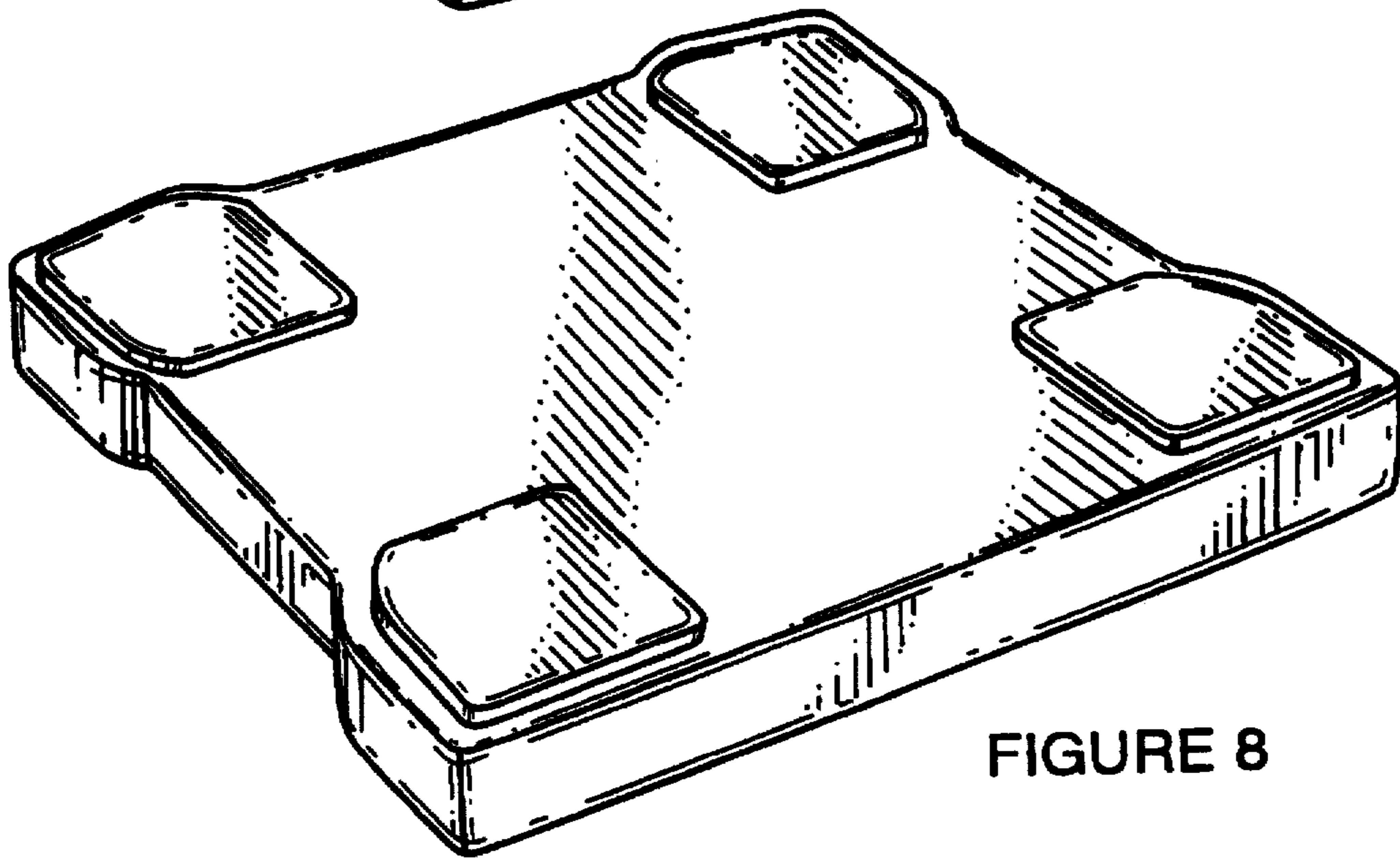

FIGURE 8

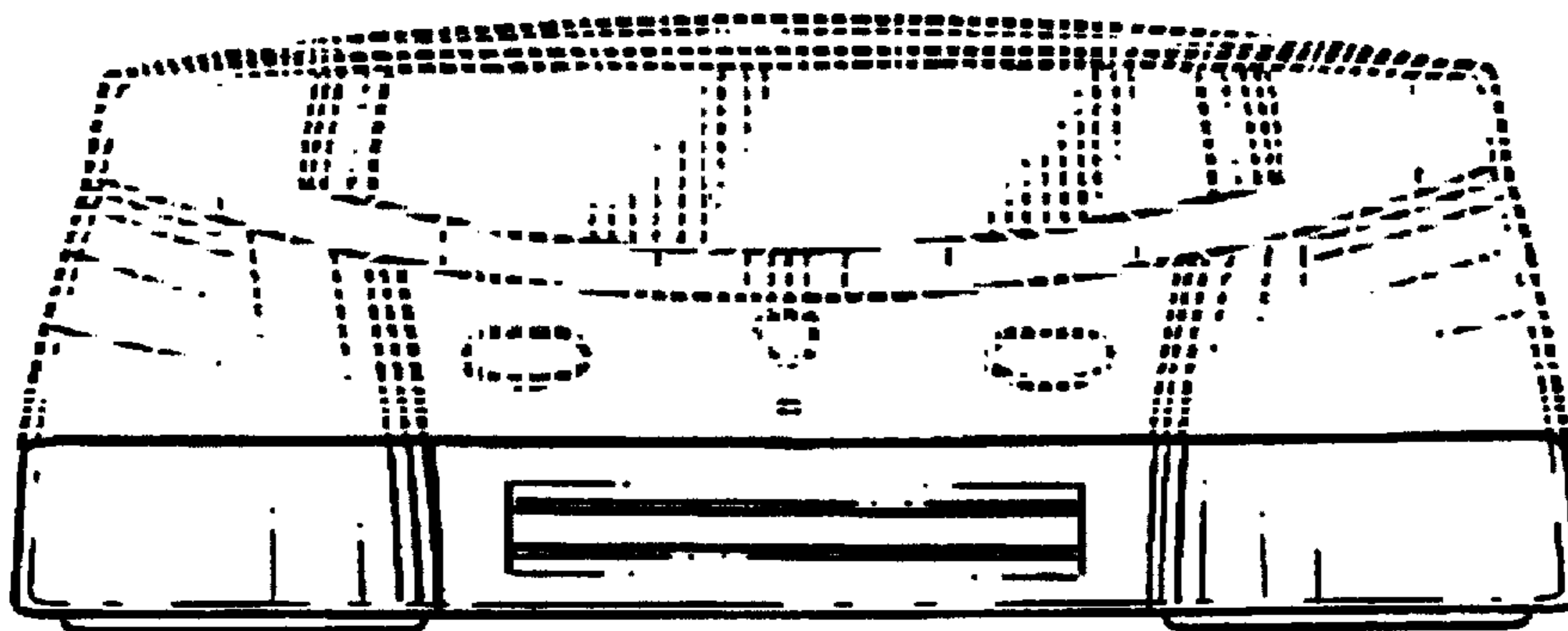

FIGURE 9