



US00D385303S

United States Patent [19]
Anders

[11] **Patent Number: Des. 385,303**
[45] **Date of Patent: **Oct. 21, 1997**

[54] **FLEXI-GRAB PAPER CLIP**

[76] **Inventor: Irving Anders, 54 Crossway, Scarsdale, N.Y. 10583**

[*] **Notice: The portion of the term of this patent subsequent to Aug. 20, 2010, has been disclaimed.**

[**] **Term: 14 Years**

[21] **Appl. No.: 50,694**

[22] **Filed: Feb. 23, 1996**

Related U.S. Application Data

[63] **Continuation-in-part of Ser. No. 43,234, Aug. 9, 1995, Pat. No. Des. 372,937.**

[51] **LOC (6) Cl. 19-02**

[52] **U.S. Cl. D19/65; D19/86; D8/395**

[58] **Field of Search D19/65, 75, 86, D19/90, 91, 99, 100; D8/395; D28/39, 40; 248/302; 24/67 R, 67.1-67.9, 326, 552, 547; 402/79**

[56] **References Cited**

U.S. PATENT DOCUMENTS

D. 199,348	10/1964	Mussy	D19/65 X
D. 304,958	12/1989	Gutjerresz	D19/65
D. 372,937	8/1996	Anders	D19/65
721,071	2/1903	McGill	248/302
1,247,087	11/1917	DeNoyer	24/67.9
1,565,501	12/1925	Robinson, Jr.	24/546
2,659,378	11/1953	Caserta	D28/39 X
3,057,027	10/1962	Bugge	24/547 X
3,095,625	7/1963	Croisant	24/67.9
3,225,469	12/1965	Chase	40/641
3,408,700	11/1968	Chase	24/67.3

FOREIGN PATENT DOCUMENTS

1128624	1/1957	France	24/67.9
---------	--------	--------	-------	---------

[57] **CLAIM**

The ornamental design for a flexi-grab paper clip, as shown and described.

DESCRIPTION

FIG. 1 is a perspective view of a flexi-grab paperclip showing my design;
 FIG. 2 is a side elevational view;
 FIG. 3 is a side elevational view of the side opposite that shown in FIG. 2;
 FIG. 4 is an end elevational view;
 FIG. 5 is an end elevational view of the end opposite that shown in FIG. 4;
 FIG. 6 is a top plan view;
 FIG. 7 is a perspective view of a second embodiment of my new design;
 FIG. 8 is a side elevational view of FIG. 7;
 FIG. 9 is a side elevational view of the side opposite that shown in FIG. 8;
 FIG. 10 is an end elevational view;
 FIG. 11 is an end elevational view of the end not shown in FIG. 10;
 FIG. 12 is a perspective view of a third embodiment of my new design;
 FIG. 13 is a side elevational view;
 FIG. 14 is a side elevational view of the side opposite that shown in FIG. 13;
 FIG. 15 is an end elevational view;
 FIG. 16 is an end elevational view of the end opposite that shown in FIG. 15;
 FIG. 17 is a top plan view;
 FIG. 18 is a perspective view of a fourth embodiment of my new design;
 FIG. 19 is a side elevational view of FIG. 18;
 FIG. 20 is a side elevational view of the side opposite that shown in FIG. 19;
 FIG. 21 is an end elevational view;
 FIG. 22 is an end elevational view of the end not shown in FIG. 21;
 FIG. 23 is an enlarged fragmentary side elevational view of the center section of the first embodiment of my design; and,
 FIG. 24 is an enlarged fragmentary side elevational view of the center section of the second embodiment of my design.

Primary Examiner—Martie Thompson

1 Claim, 5 Drawing Sheets

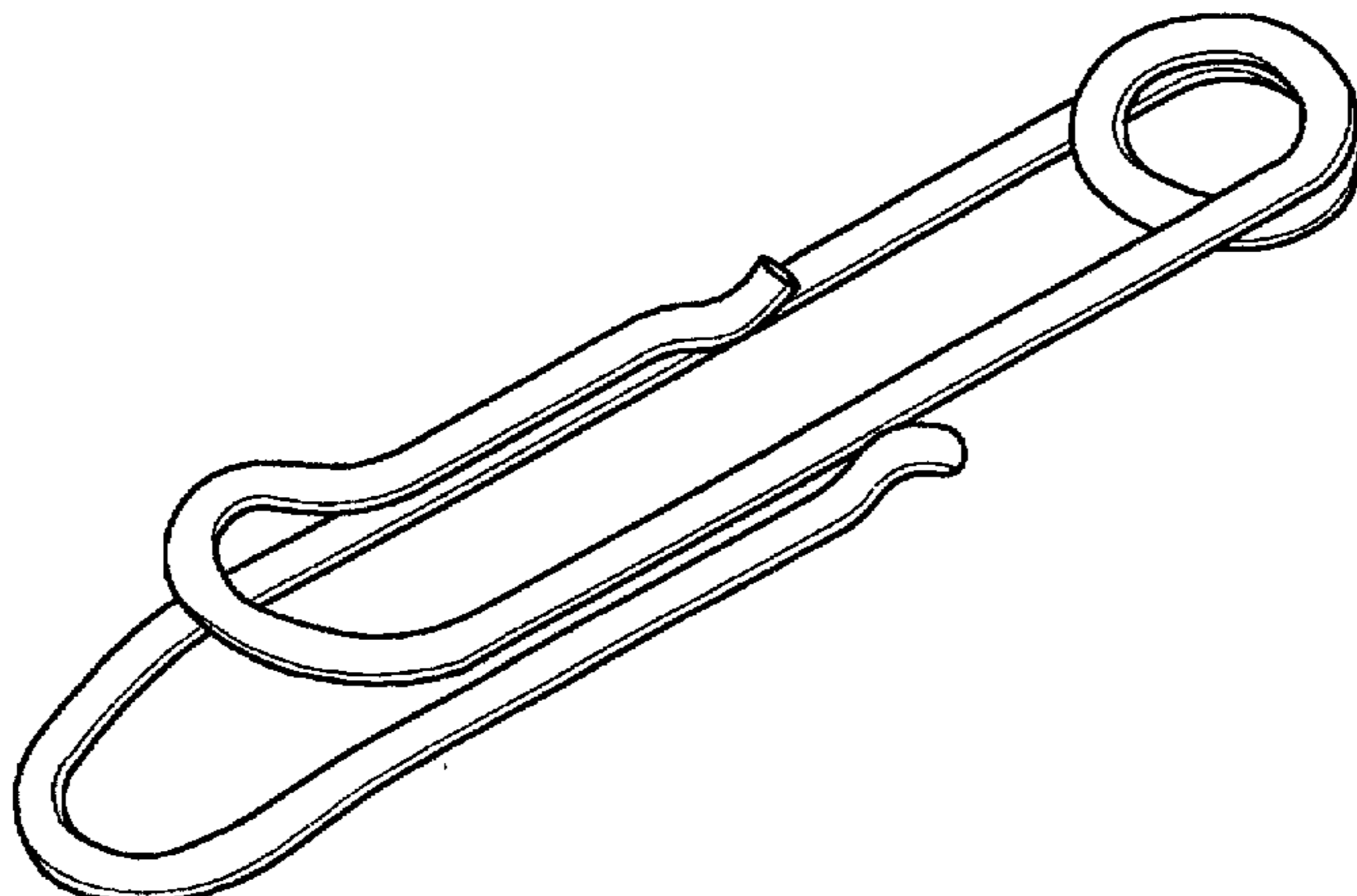

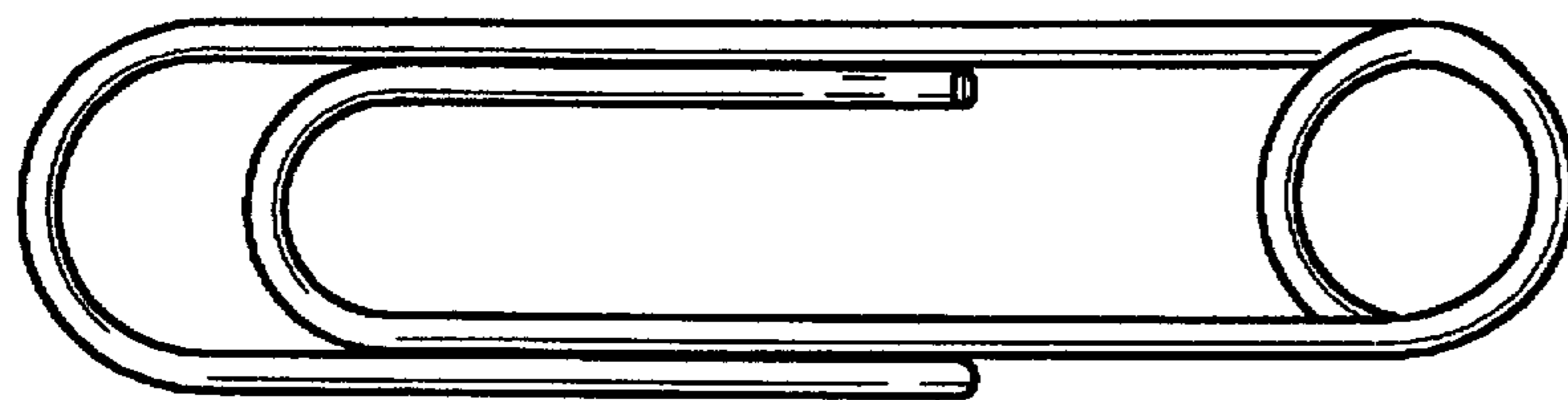

FIG. 6

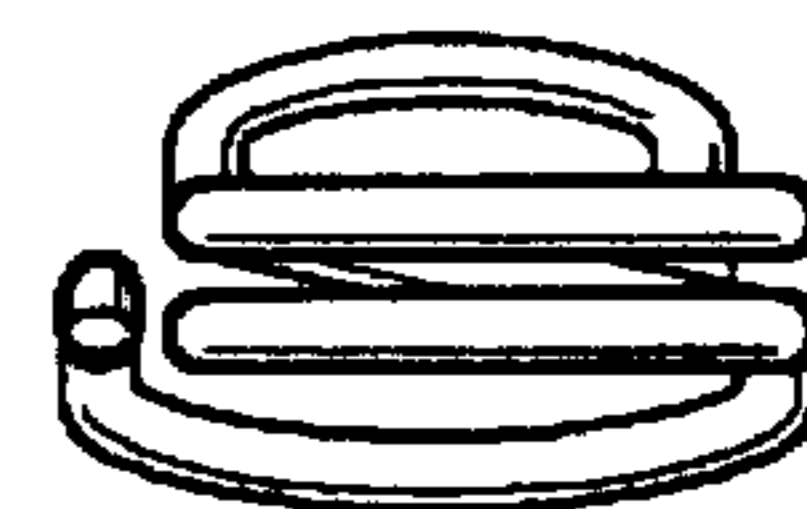

FIG. 5

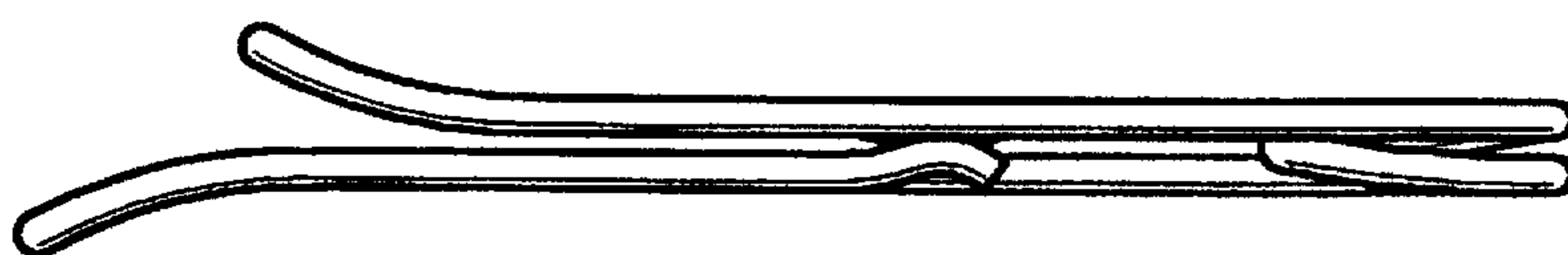

FIG. 3

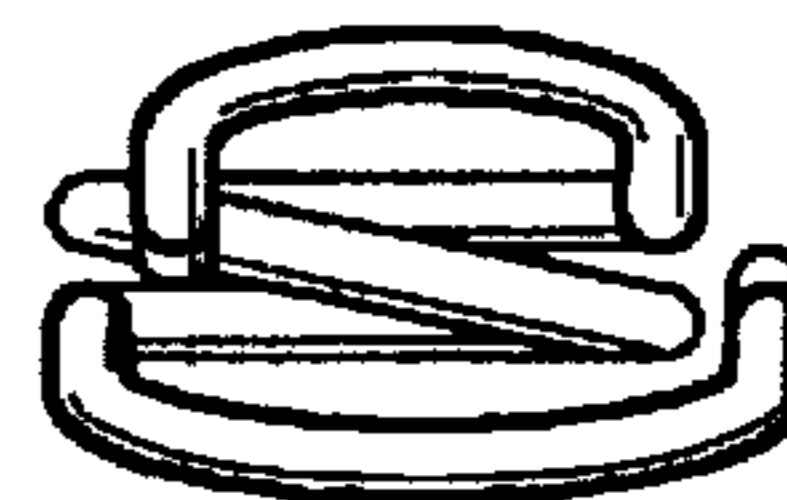

FIG. 4



FIG. 2

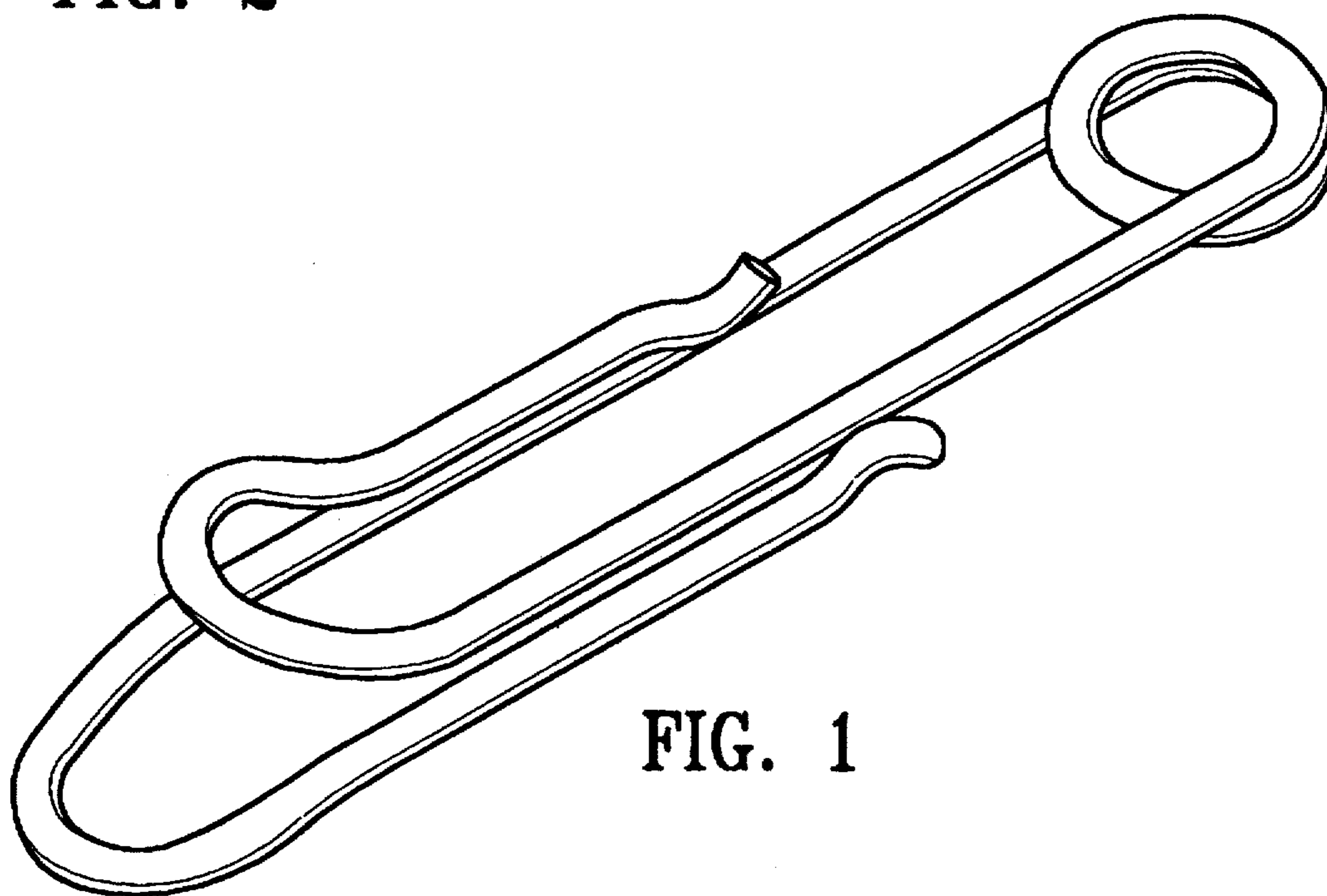

FIG. 1

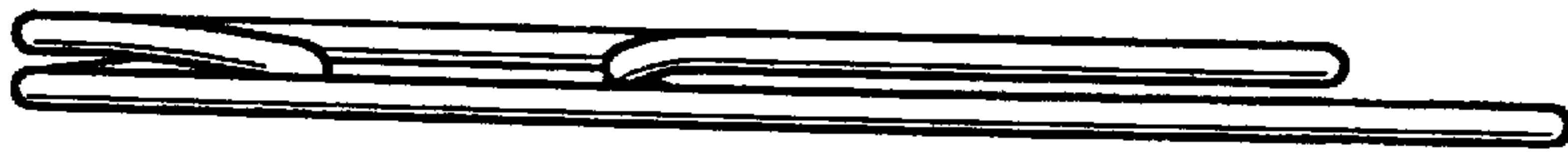

FIG. 9

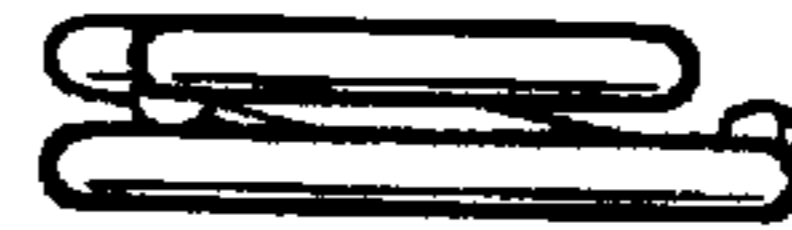

FIG. 11

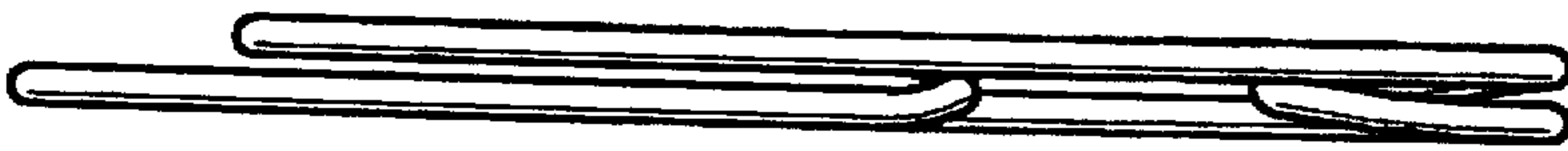

FIG. 8

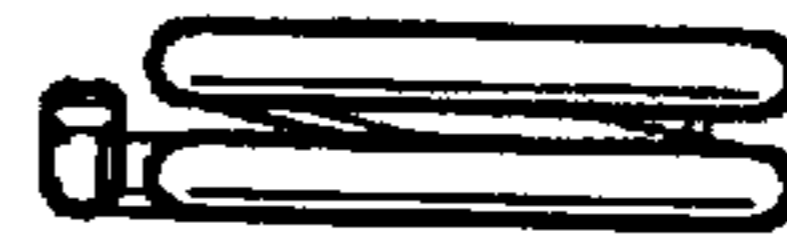

FIG. 10

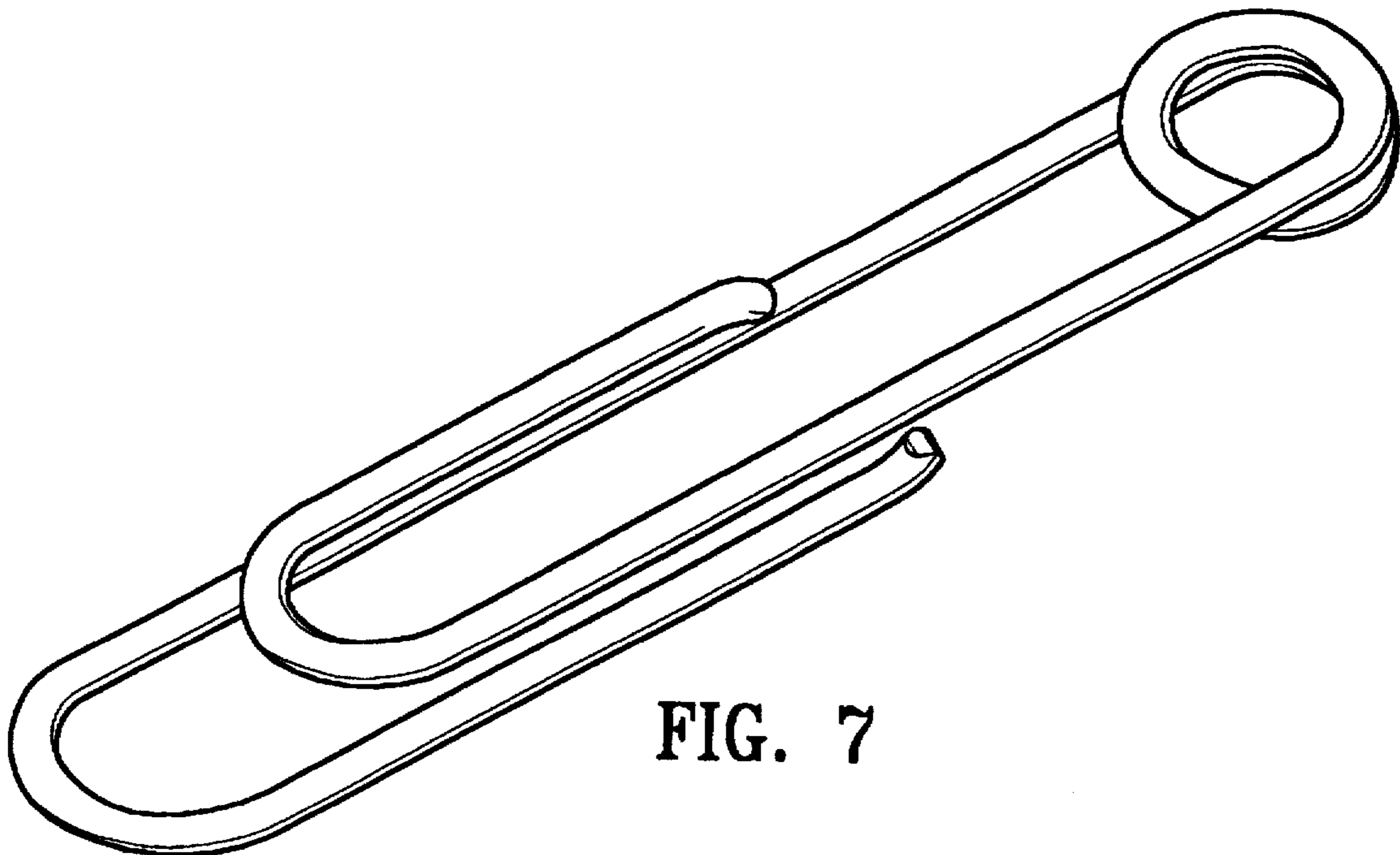

FIG. 7

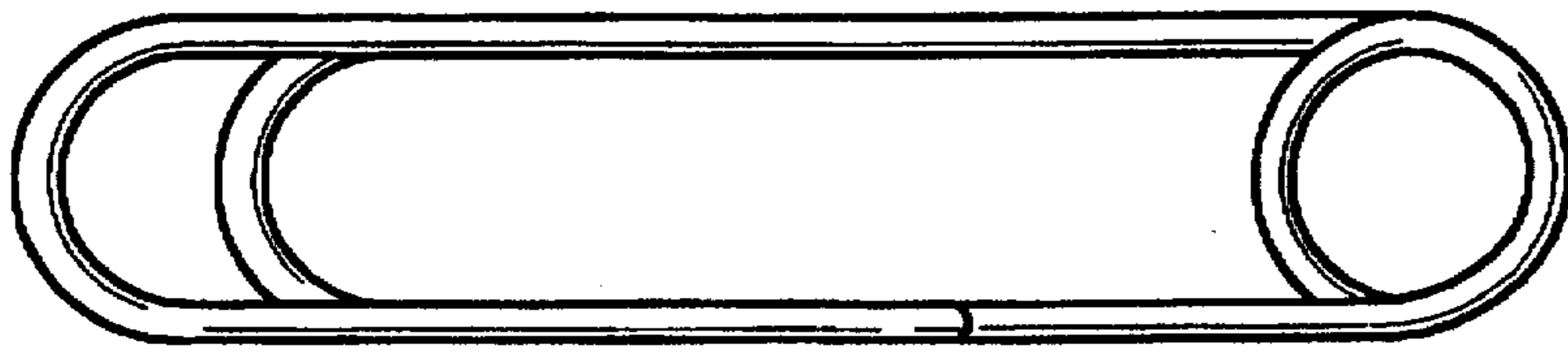

FIG. 17

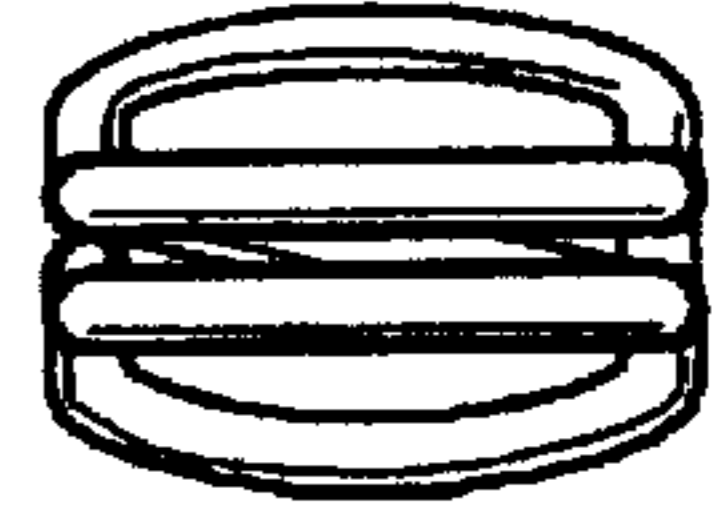

FIG. 16



FIG. 14

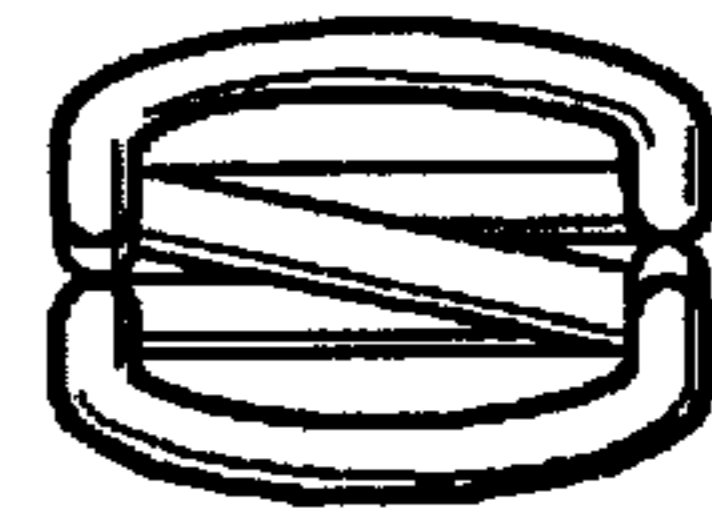

FIG. 15



FIG. 13

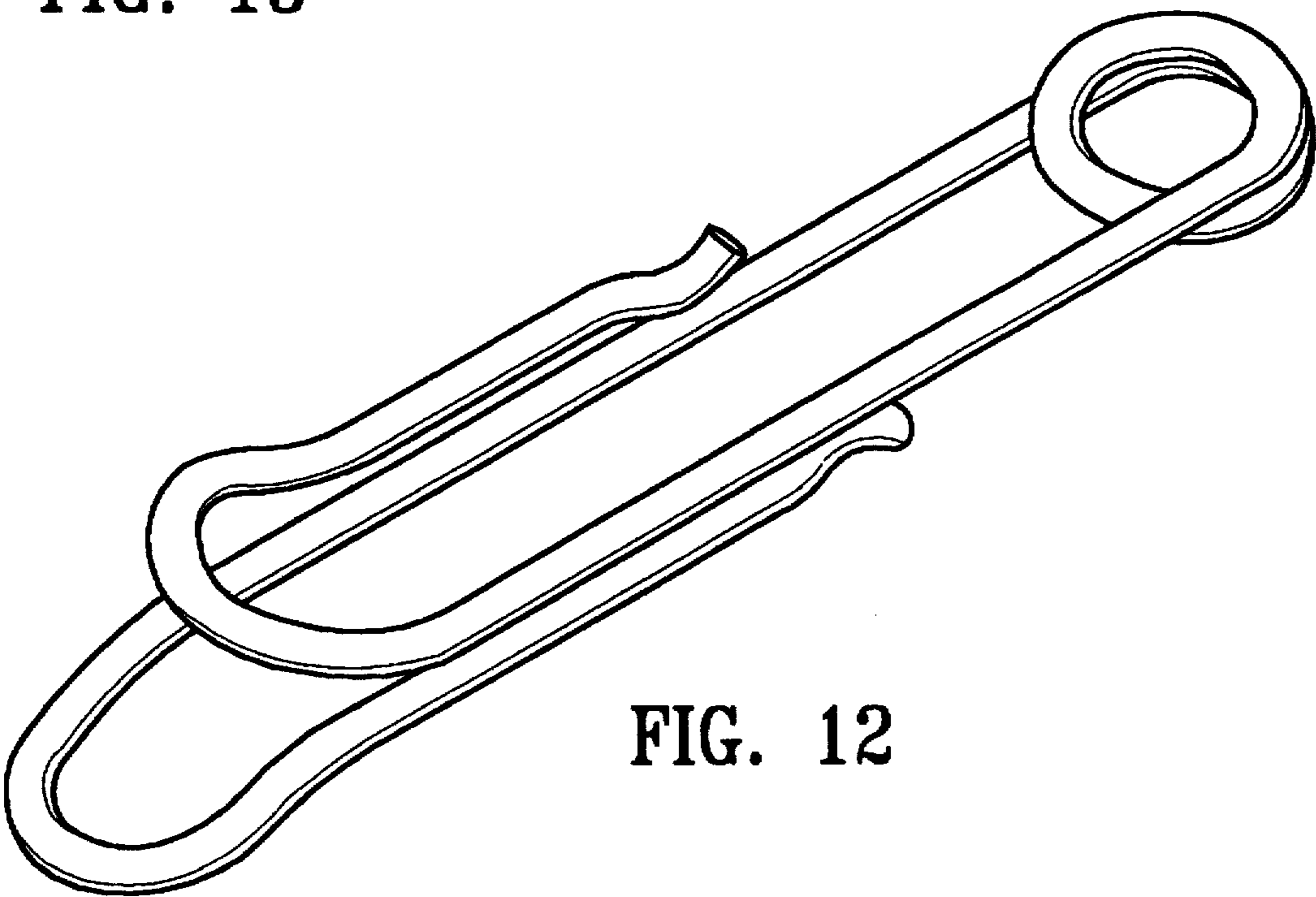

FIG. 12

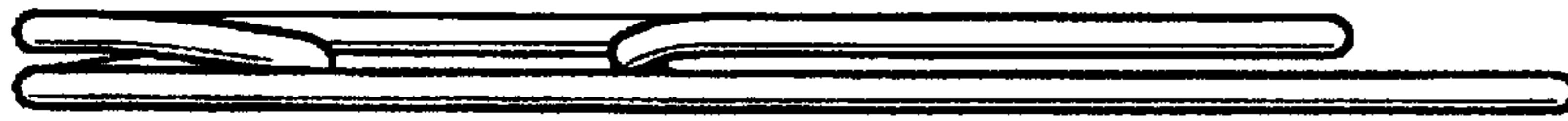

FIG. 20

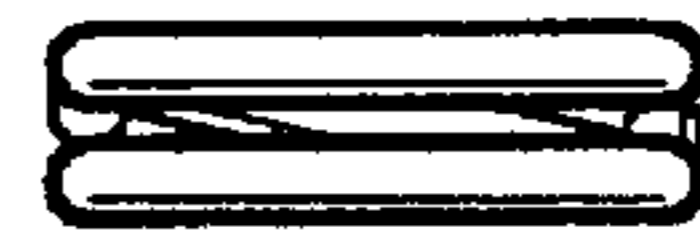

FIG. 22

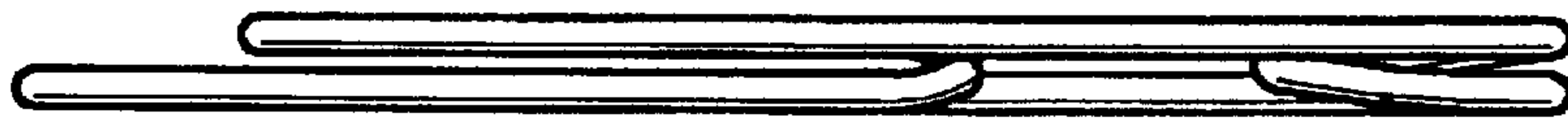

FIG. 19

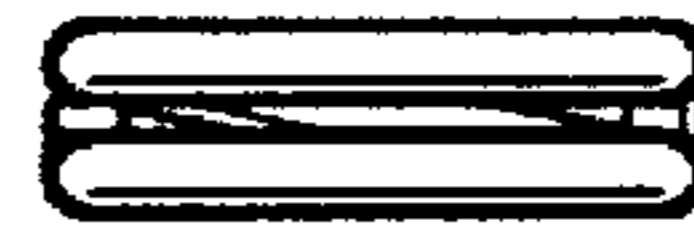

FIG. 21

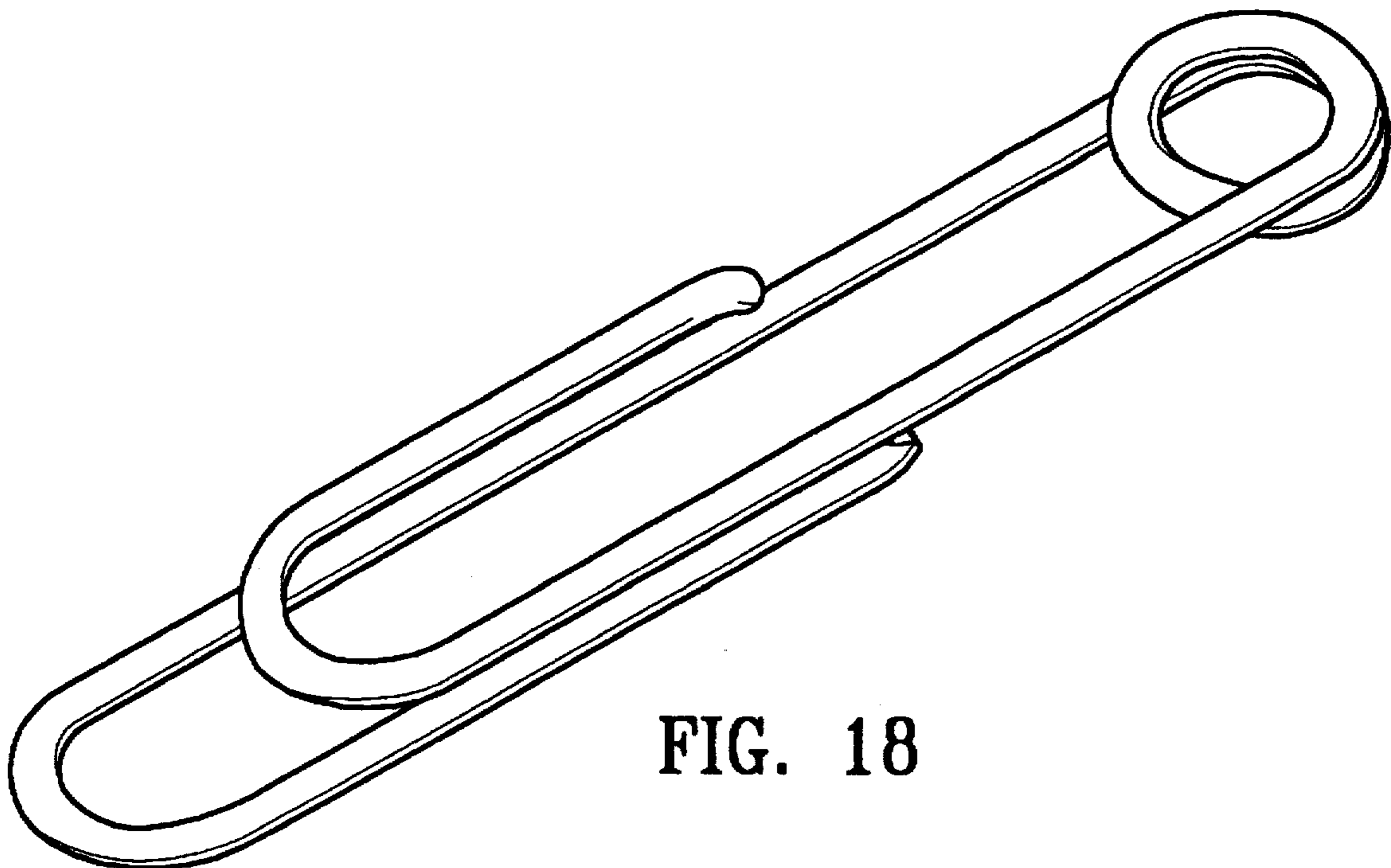

FIG. 18

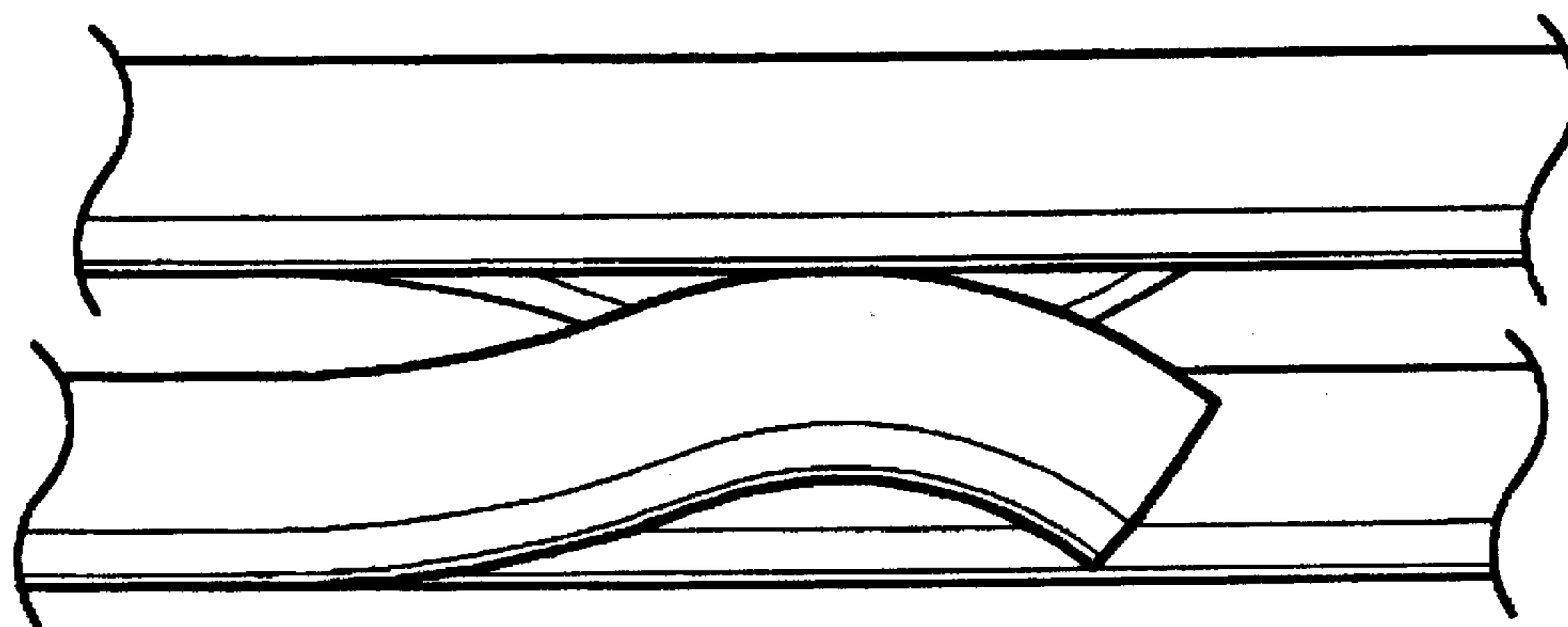

FIG. 23

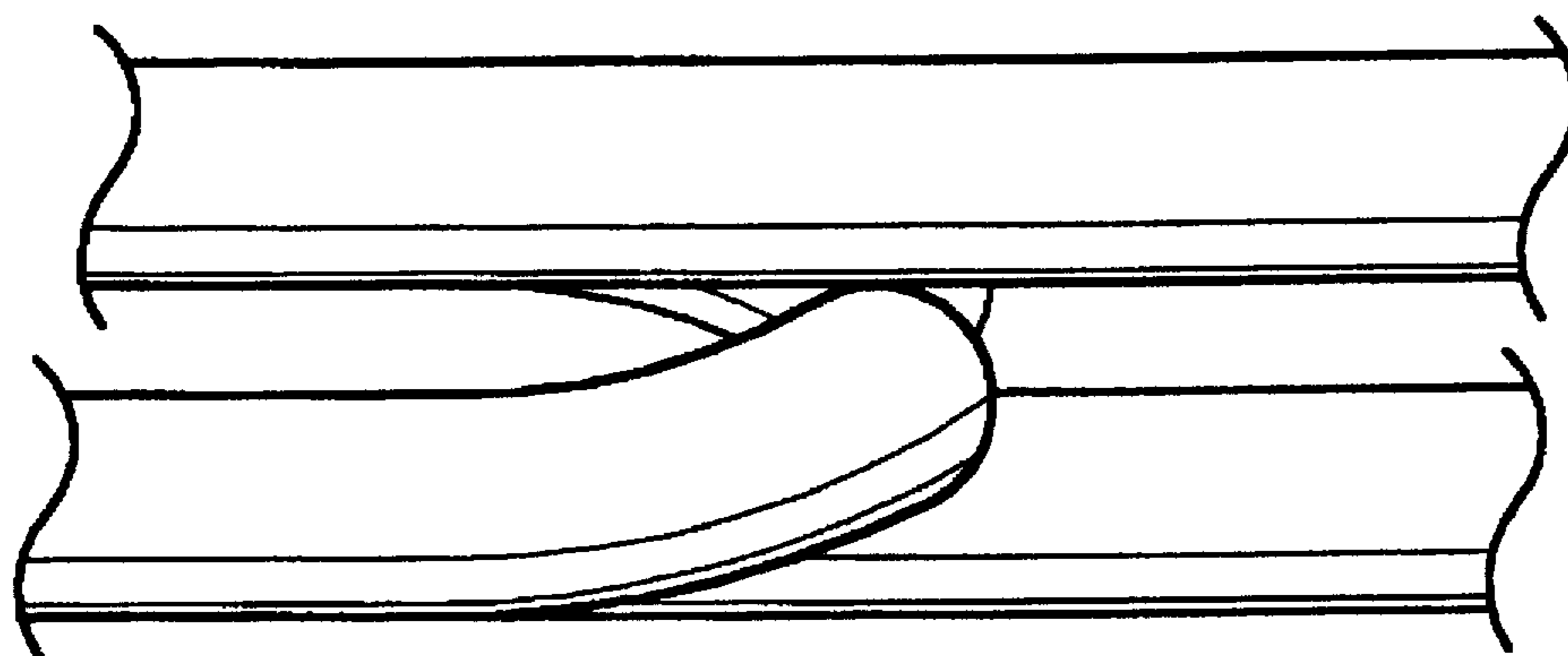

FIG. 24