



US00D385223S

United States Patent [19]

[11] Patent Number: **Des. 385,223**

Marlowe et al.

[45] Date of Patent: ****Oct. 21, 1997**

[54] **TRUCK CAB ROOF**

4,775,179	10/1988	Riggs	296/180.2
5,078,448	1/1992	Selzer et al.	296/180.2
5,249,837	10/1993	Luttrell	296/180.3

[75] Inventors: **Huston R. Marlowe, Plano; John C. Lindsley, Argyle, both of Tex.**

Primary Examiner—Melody N. Brown
Attorney, Agent, or Firm—Flehr Hohbach Test Albritton & Herbert LLP

[73] Assignee: **Paccar Inc., Bellevue, Wash.**

[**] Term: **14 Years**

[57] CLAIM

[21] Appl. No.: **56,030**

The ornamental design for a truck cab roof, as shown and described.

[22] Filed: **Jun. 20, 1996**

DESCRIPTION

[51] LOC (6) Cl. **12-08**

[52] U.S. Cl. **D12/96**

[58] Field of Search D12/96; 296/180.1-180.3,
296/190

FIG. 1 is a top perspective view of a truck cab roof showing our new design, it being understood that the broken lines are for illustrative purposes only and form no part of the claimed design;

FIG. 2 is a top perspective view thereof;

FIG. 3 is a top plan view thereof;

FIG. 4 is a front elevation view thereof;

FIG. 5 is a side elevation view of one side thereof, the opposite side being a mirror-image of the one side; and,

FIG. 6 is a rear elevation view thereof.

[56] References Cited

U.S. PATENT DOCUMENTS

D. 299,706	2/1989	Whitmer et al.	D12/96
D. 319,807	9/1991	Simons et al.	D12/96
3,972,556	8/1976	Mason, Jr.	296/180.2
4,018,472	4/1977	Mason, Jr.	296/180.2
4,611,796	9/1986	Orr	296/180.2

1 Claim, 2 Drawing Sheets

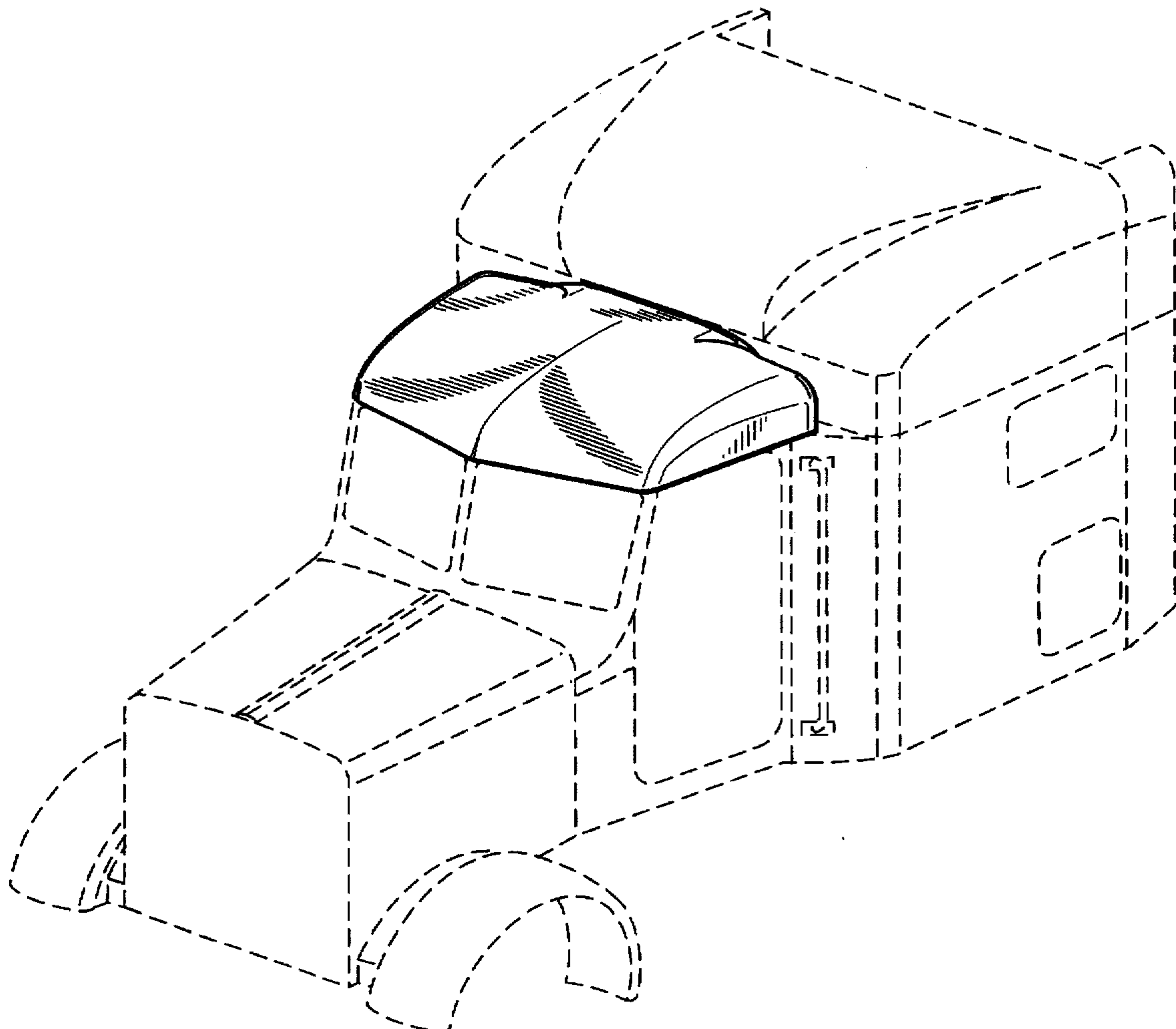

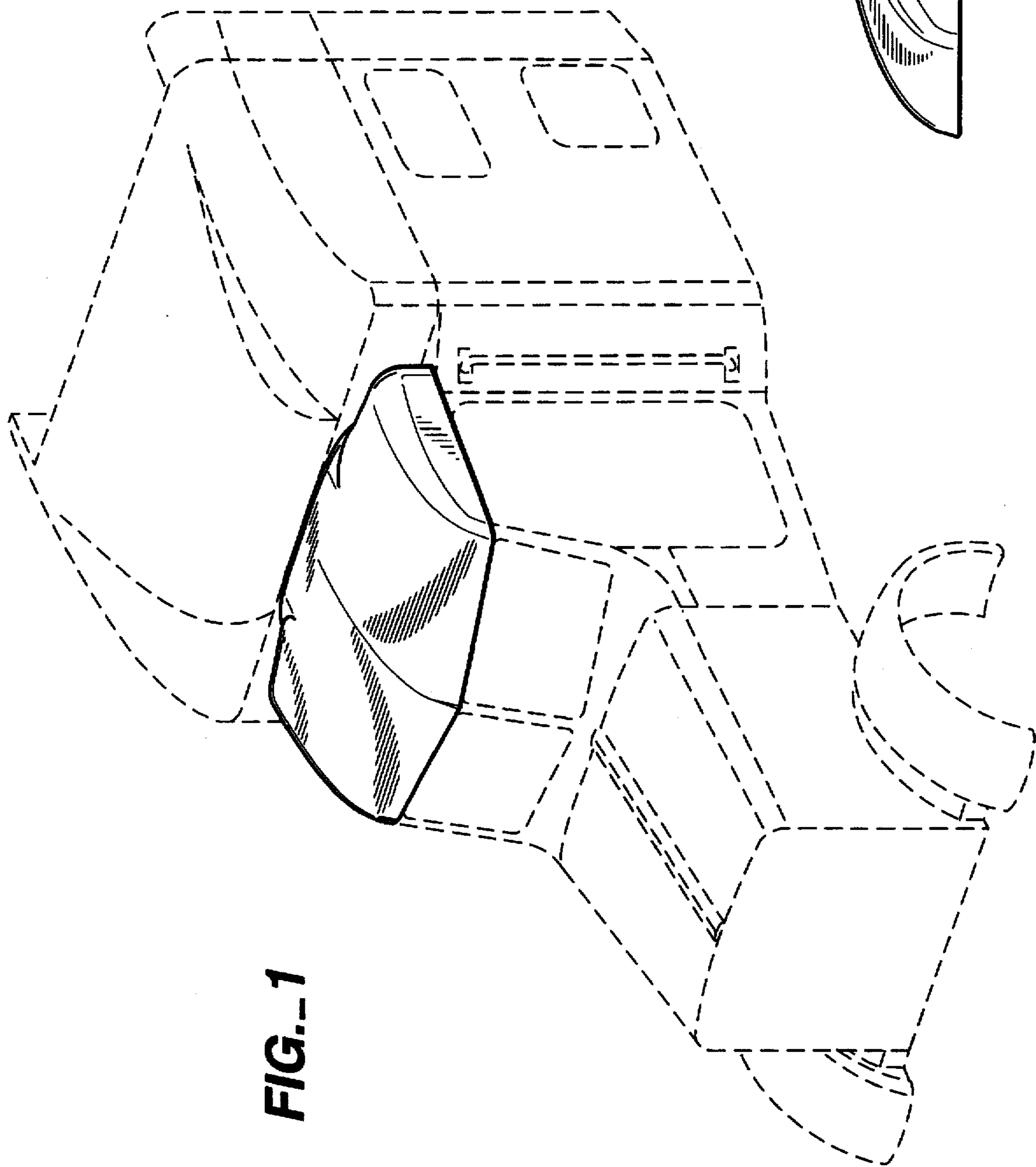

FIG.-1

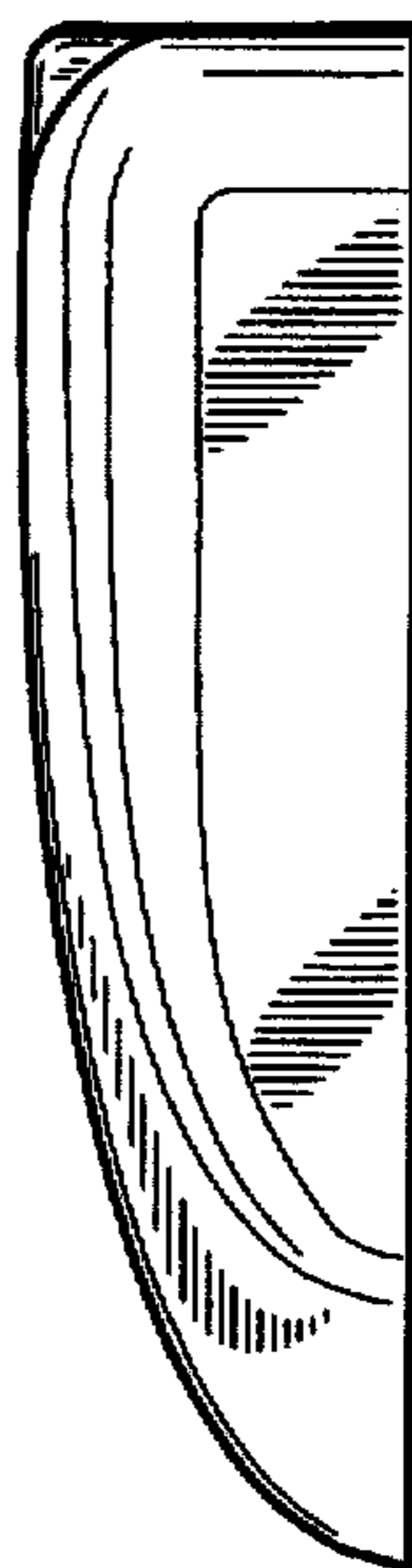

FIG.-5

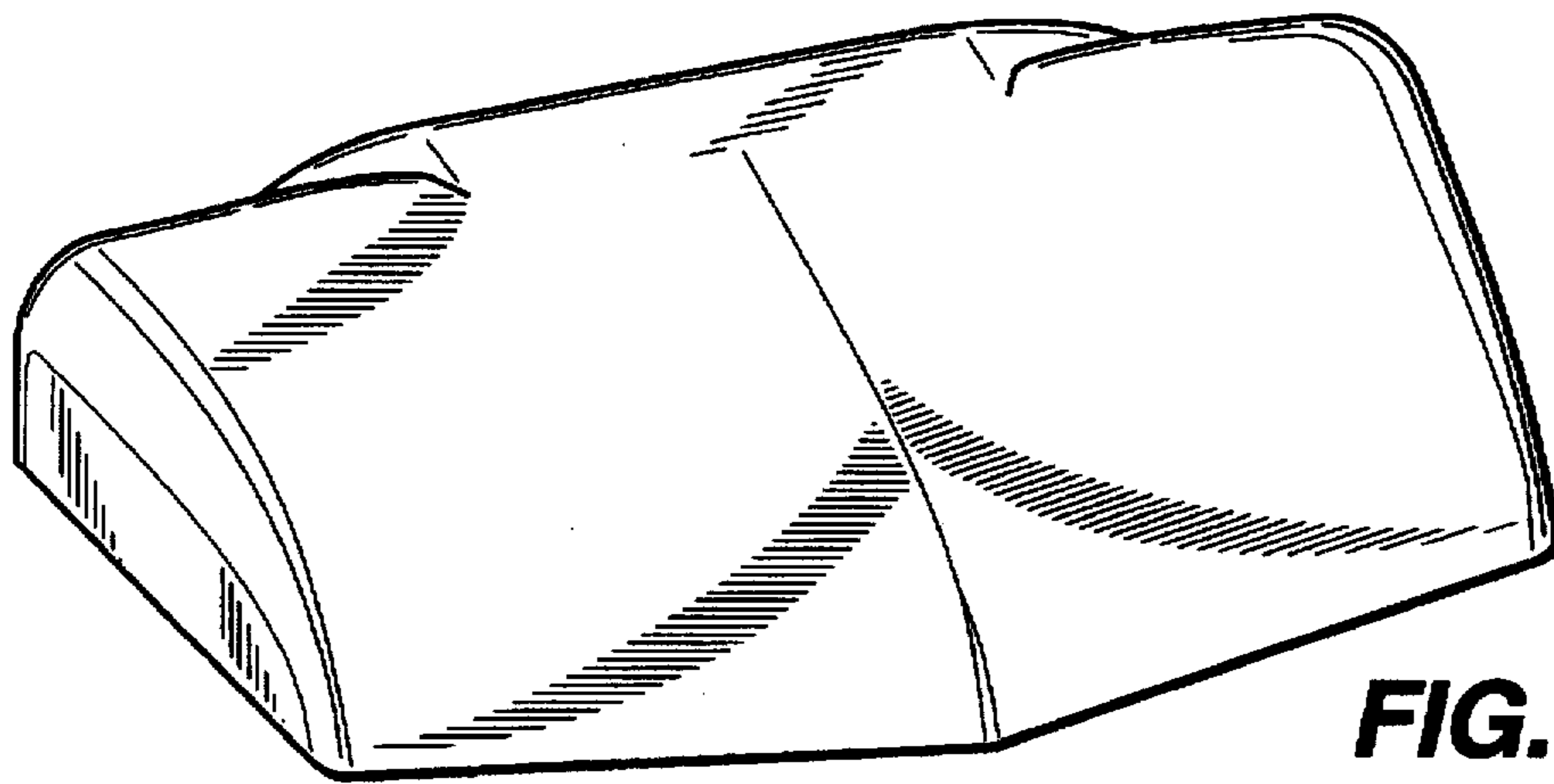

FIG._2

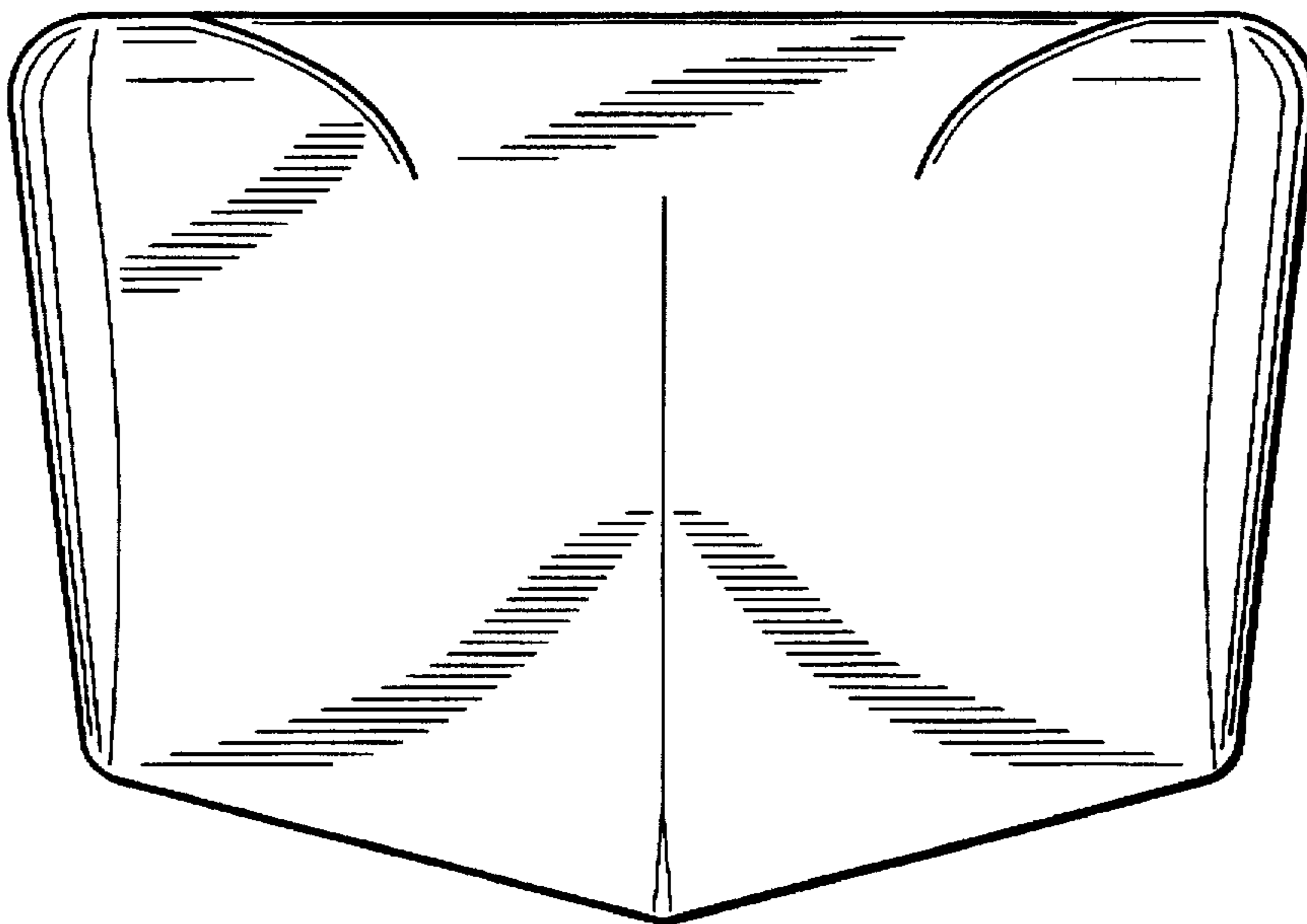

FIG._3

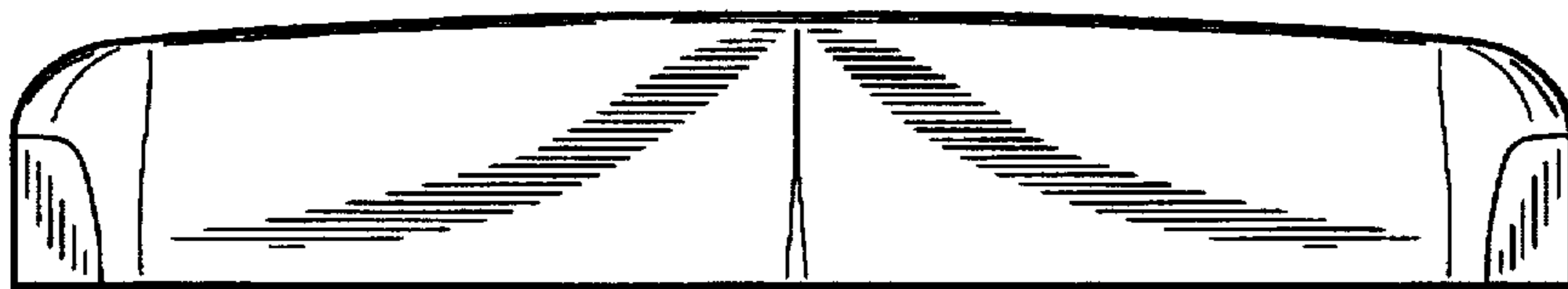

FIG._4

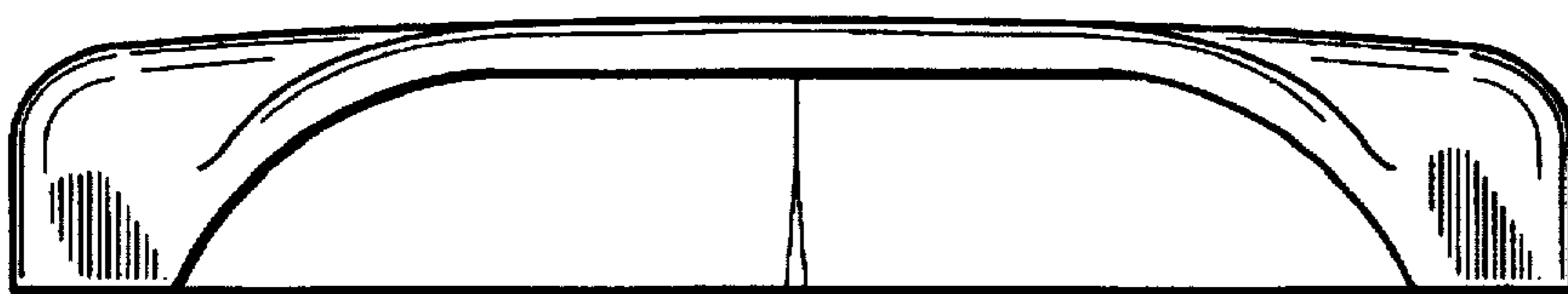

FIG._6