

US00D385220S

United States Patent [19]

[11] Patent Number: **Des. 385,220**

Warkuss et al.

[45] Date of Patent: ****Oct. 21, 1997**

[54] **AUTOMOBILE BODY**

D. 367,440 2/1996 Mays D12/90

[75] Inventors: **Hartmut Warkuss, Ummern; Gregory Guillaume, Braunschweig, both of Germany**

Primary Examiner—Melody N. Brown
Attorney, Agent, or Firm—Watson Cole Stevens Davis, P.L.L.C.

[73] Assignee: **Volkswagen AG, Wolfsburg, Germany**

[57] **CLAIM**

[**] Term: **14 Years**

The ornamental design for an automobile body, as shown and described.

[21] Appl. No.: **54,271**

DESCRIPTION

[22] Filed: **May 10, 1996**

FIG. 1 is a front perspective view of a new and ornamental design for an automobile body according to the present invention;

[30] **Foreign Application Priority Data**

Oct. 25, 1995 [DE] Germany M9508476.2

FIG. 2 is a left side view of the automobile body of FIG. 1 the right side view being identical;

[51] LOC (6) Cl. **12-08**

[52] U.S. Cl. **D12/90**

FIG. 3 is a front view of the automobile body according to the invention;

[58] Field of Search D12/86, 90-92;
296/185

FIG. 4 is a rear view of the automobile body according to the invention; and,

[56] **References Cited**

U.S. PATENT DOCUMENTS

D. 352,482 11/1994 Cannara et al. D12/90

FIG. 5 is a top view of the automobile body according to the invention, the wheels, mirrors and spoiler shown in dotted lines form no part of the design.

1 Claim, 4 Drawing Sheets

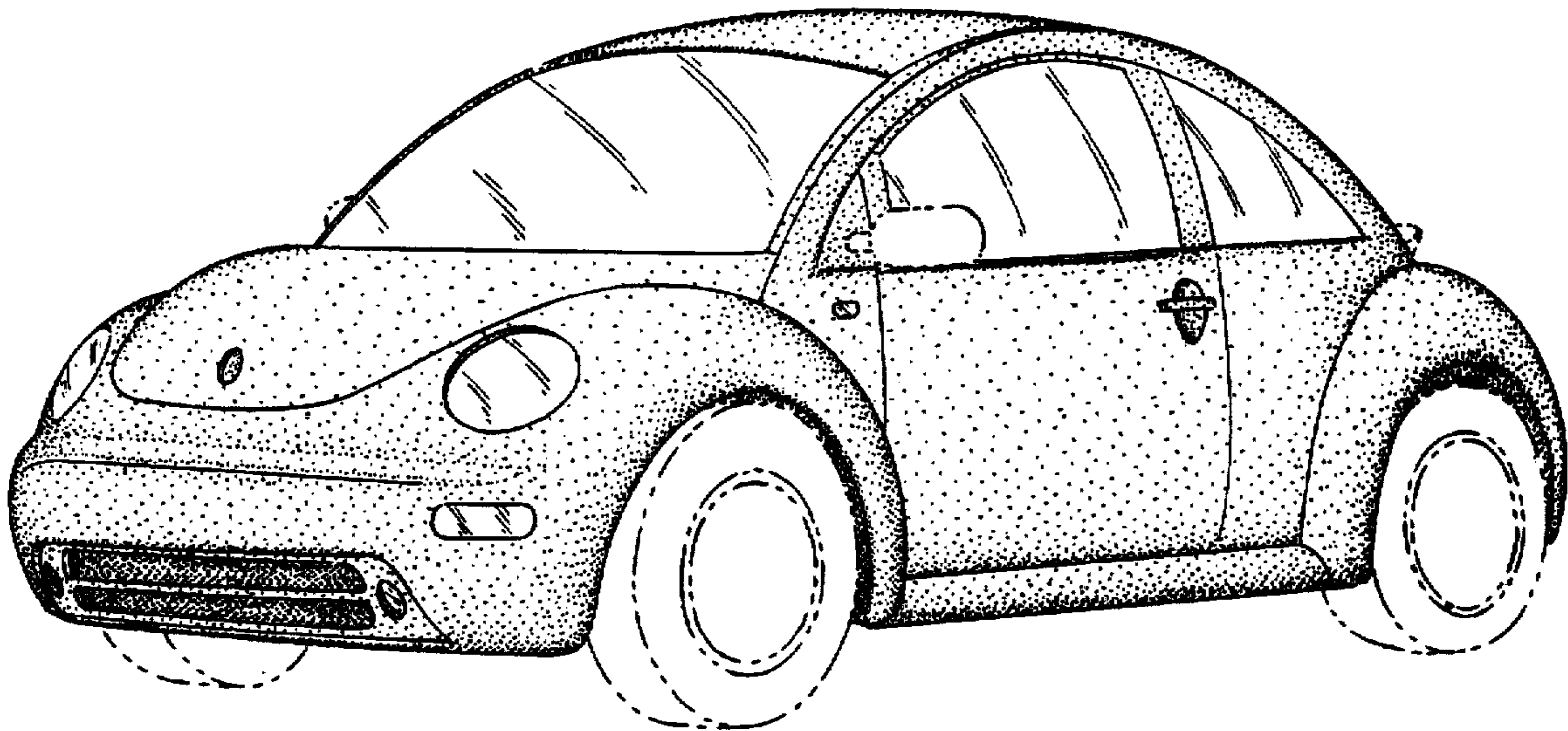

FIG. 1

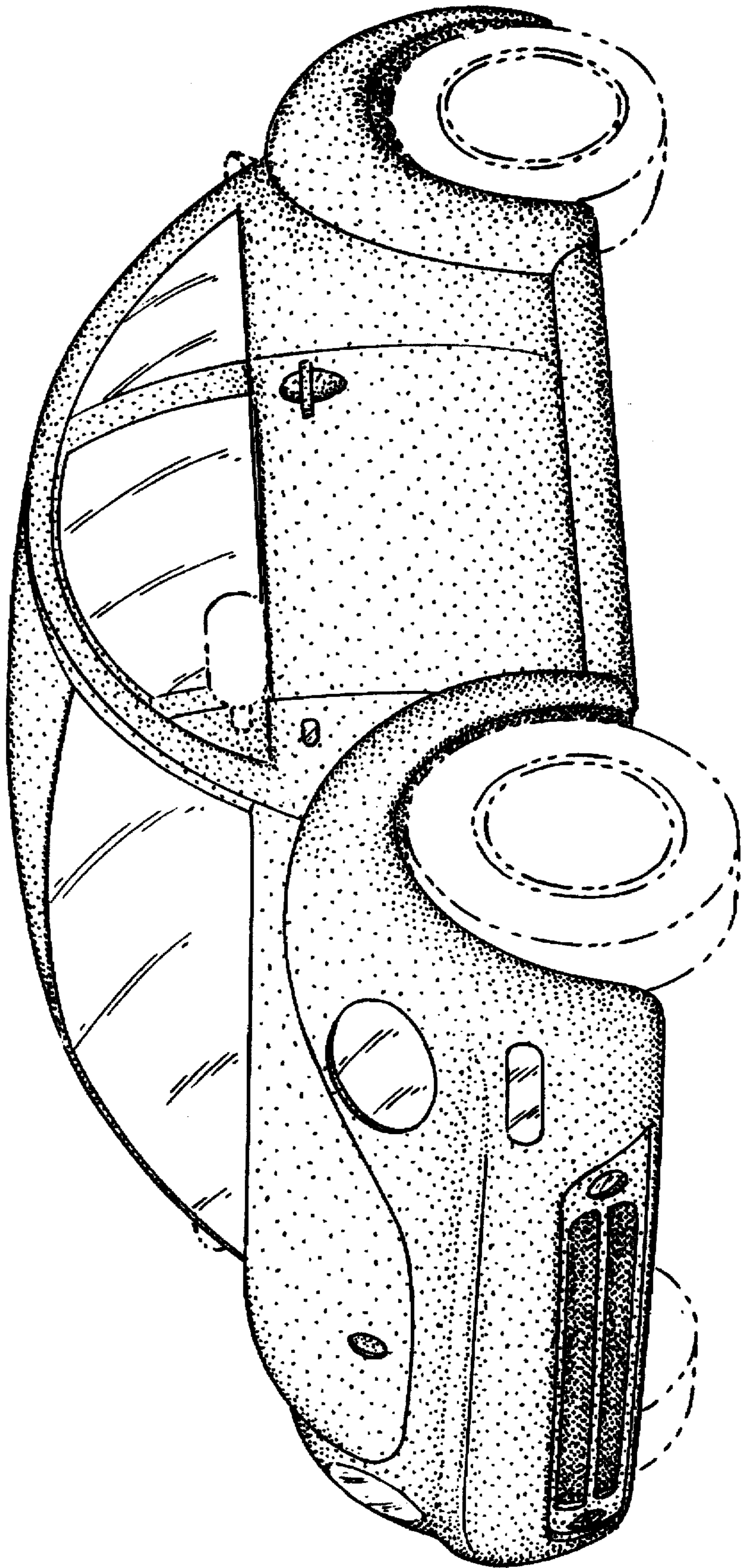

FIG. 2

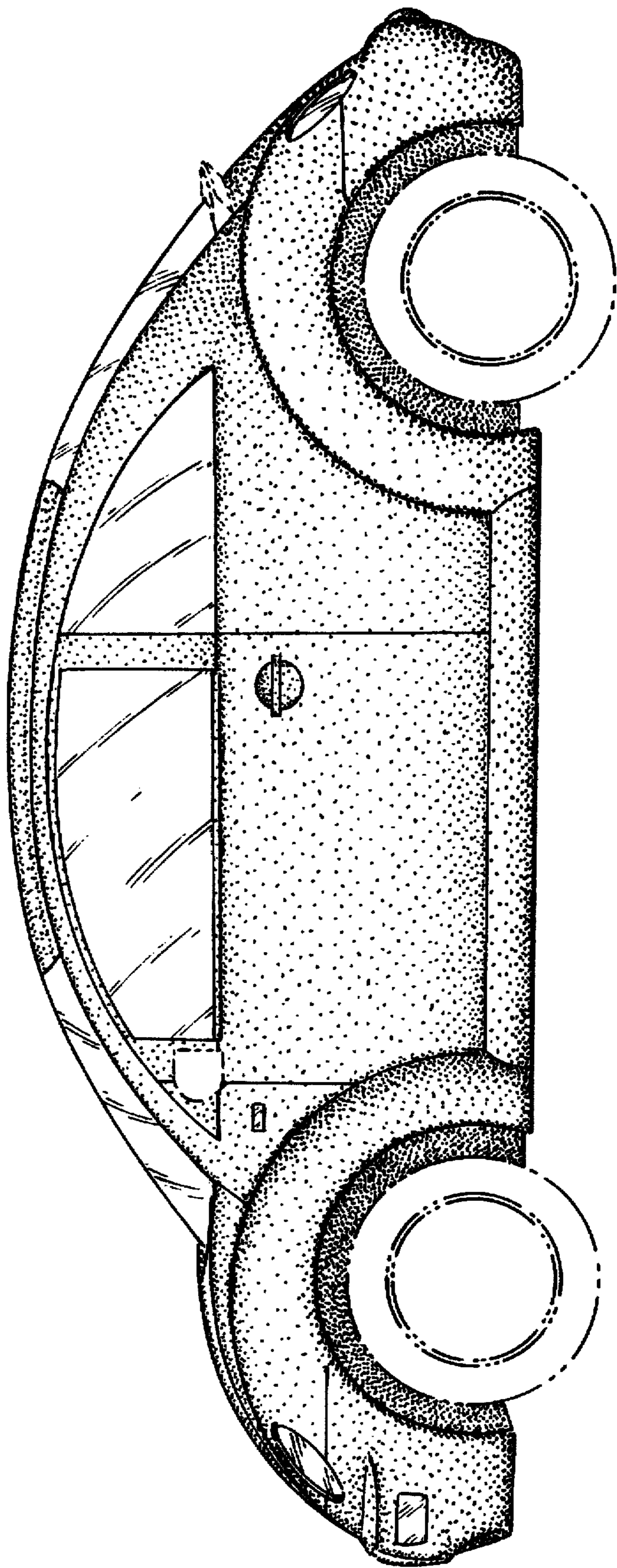

FIG. 3

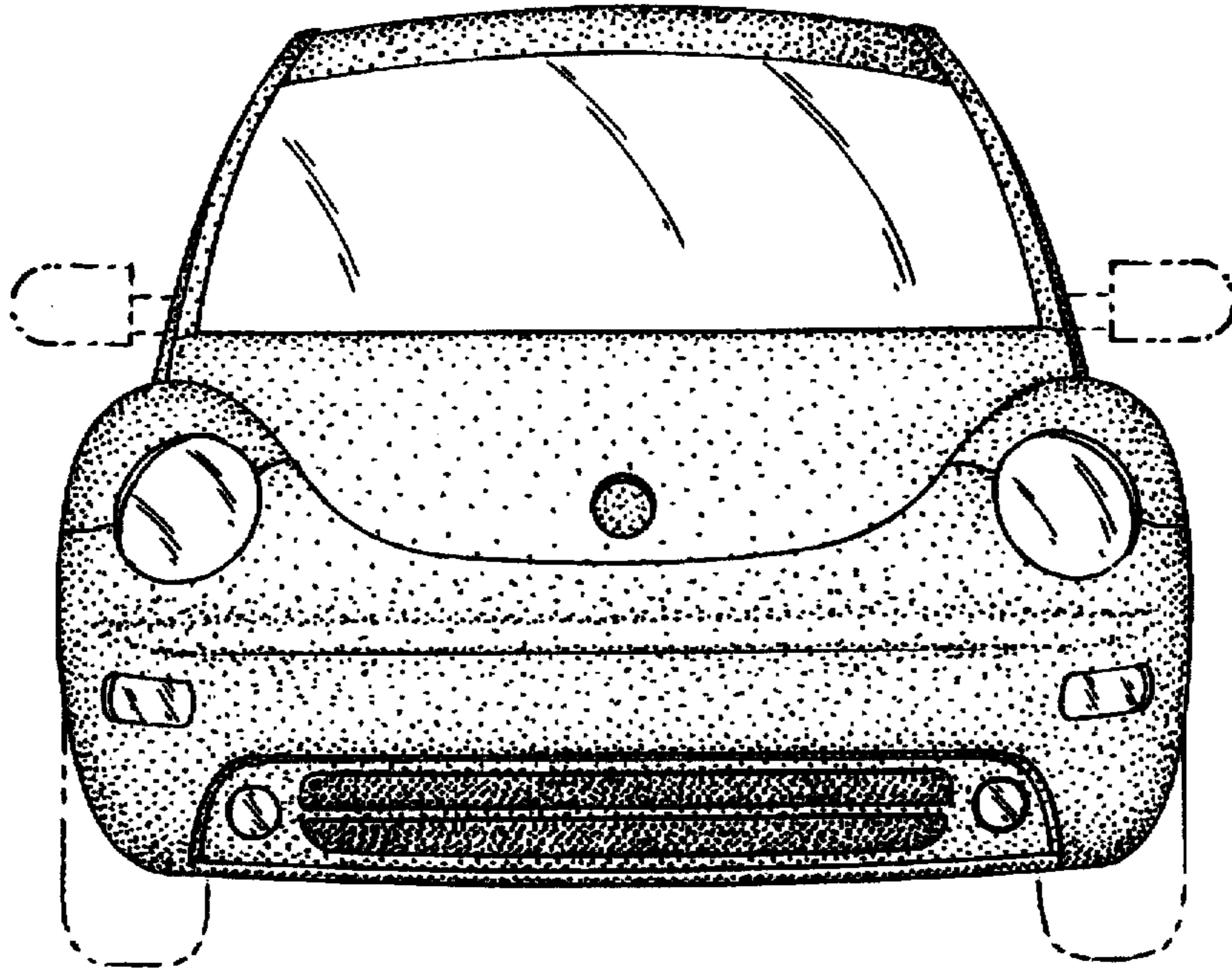

FIG. 4

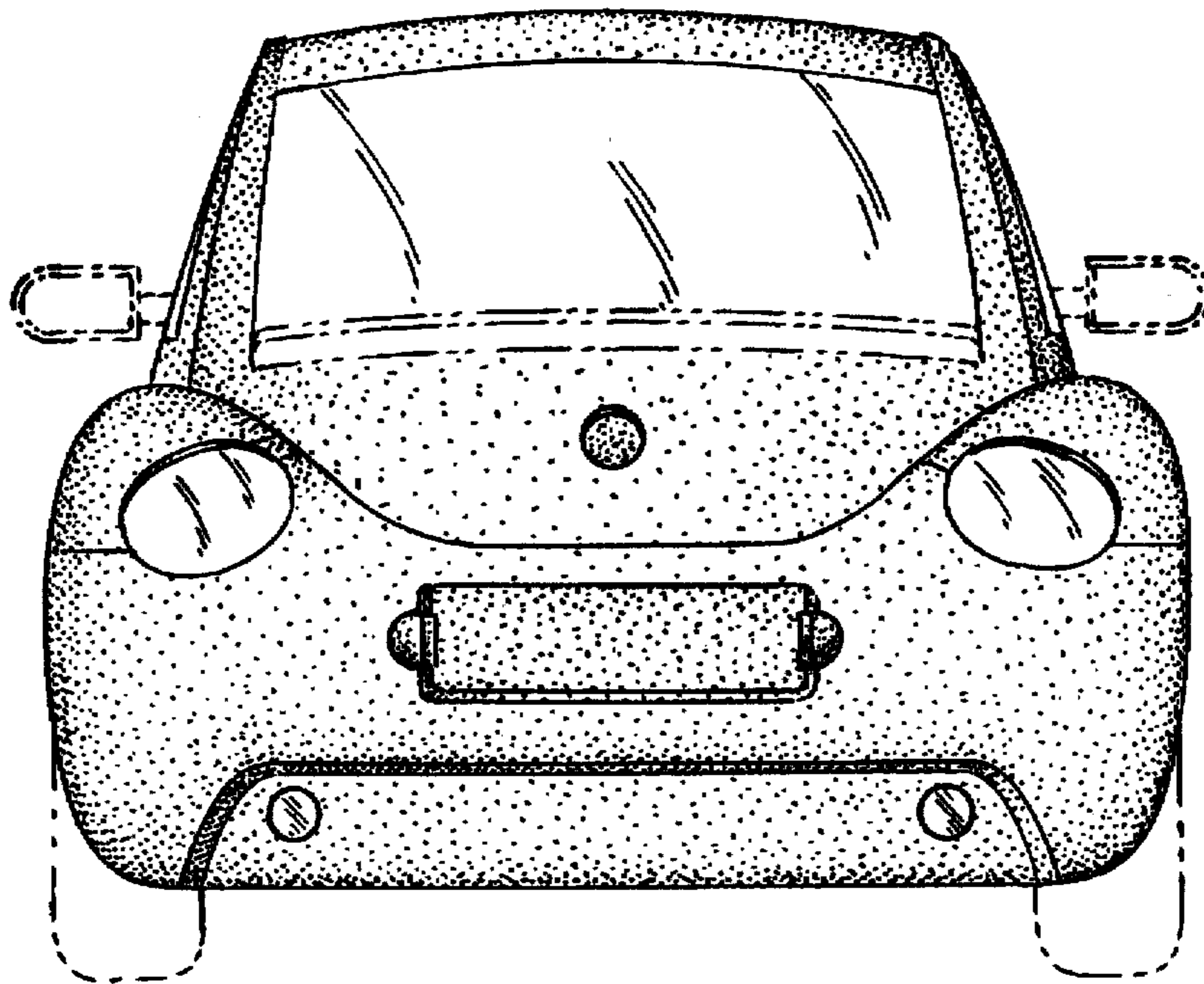

FIG. 5

