



US00D385132S

# United States Patent [19] Sagol

[11] Patent Number: Des. 385,132

[45] Date of Patent: \*\*Oct. 21, 1997

[54] MODULAR SHELF STAND

[75] Inventor: Sami Sagol, Ramat Hasharon, Israel

[73] Assignee: Keter Plastic Limited, Jaffa, Israel

[\*\*] Term: 14 Years

[21] Appl. No.: 17,716

[22] Filed: Jan. 19, 1994

[30] Foreign Application Priority Data

Jul. 19, 1993 [IL] Israel ..... 21129

[51] LOC (6) Cl. .... 06-04

[52] U.S. Cl. .... D6/479; D6/511

[58] Field of Search ..... D6/365, 396, 403,  
D6/405, 406, 407, 449, 455, 456, 458,  
461, 462, 465, 477-479, 487, 488, 511,  
525; 108/59, 91, 106, 153, 161; 211/34,  
42, 49.1, 181, 182; 248/163.1, 218.4; D25/65,  
68

[56] References Cited

U.S. PATENT DOCUMENTS

D. 218,161	7/1970	Kadison	.....	D6/572
D. 240,377	7/1976	Goulder	.....	D6/461
D. 241,297	9/1976	Maslow	.....	D6/511
D. 291,165	8/1987	Ray	.....	D6/465
D. 338,792	8/1993	Chap et al.	.....	D6/511
2,944,780	7/1960	Monk	.....	248/218.4
4,815,394	3/1989	Ettlinger et al.	.....	D6/511

FOREIGN PATENT DOCUMENTS

1481295 4/1967 France ..... 108/59

Primary Examiner—B. J. Bullock  
Assistant Examiner—Cathron B. Matta  
Attorney, Agent, or Firm—Reising, Ethington, Barnard & Perry

[57] CLAIM

The ornamental design for a modular shelf stand, as shown and described.

DESCRIPTION

FIG. 1 is a perspective view of a modular shelf stand showing my new design;

FIG. 2 is a top plan view thereof;

FIG. 3 is a front elevational view thereof, the rear being identical thereto;

FIG. 4 is a side elevational view thereof, the opposite side being identical thereto;

FIG. 5 is an enlarged fragmentary bottom plan view of one end thereof;

FIG. 6 is a cross-sectional view taken along 6—6 shown in FIG. 2 and FIG. 3; and,

FIG. 7 is a side elevational view of a second embodiment of my new design on a greatly reduced scale; it being understood that the sole difference is the addition of a fourth shelf and that the broken line showing of a fifth shelf is for illustrative purposes only and forms no part of the claimed design.

The dashed lines shown in FIGS. 1 and 2 indicate that the pattern of openings is repeated uniformly throughout the length of the stand shelves.

1 Claim, 2 Drawing Sheets

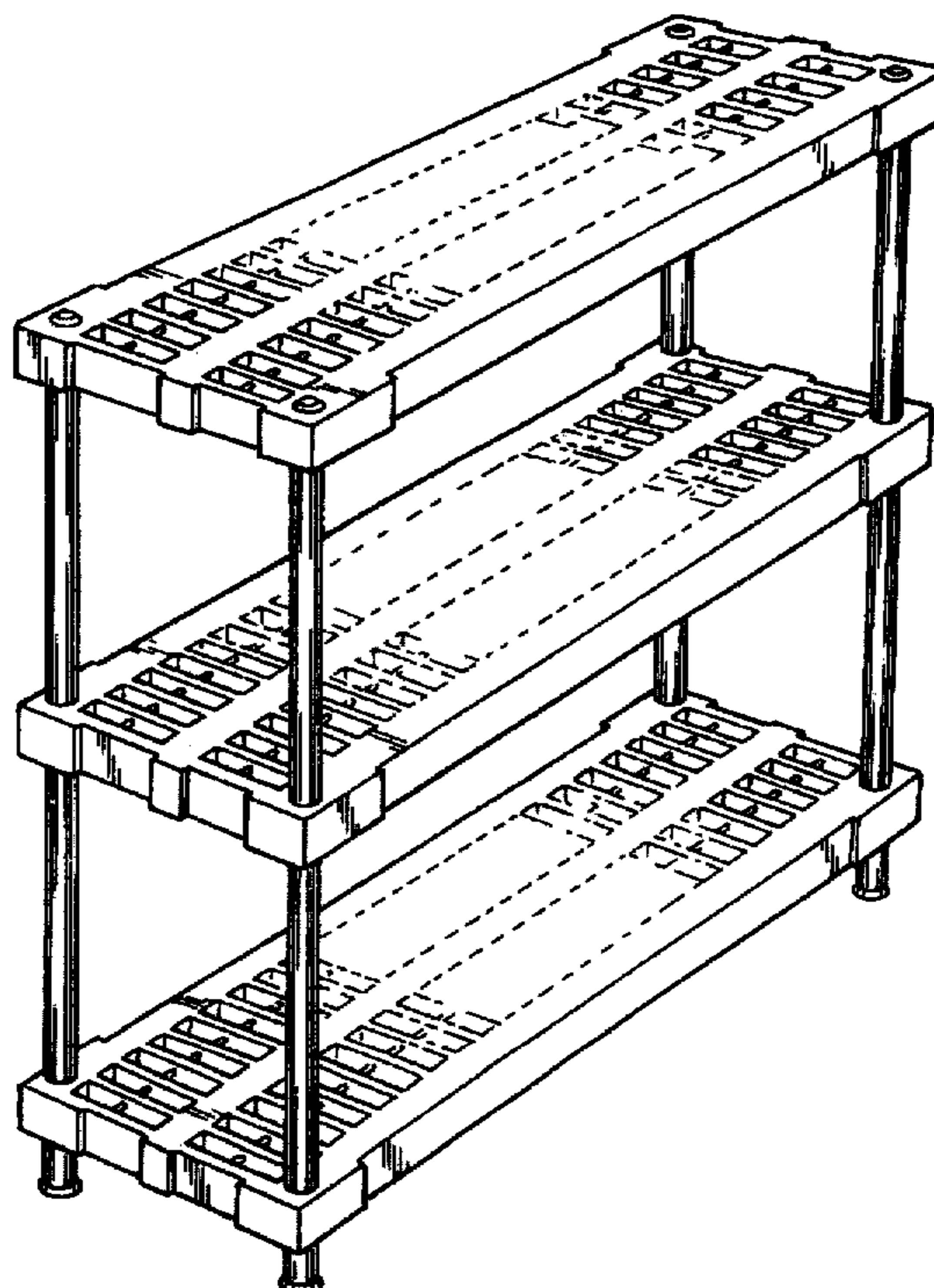

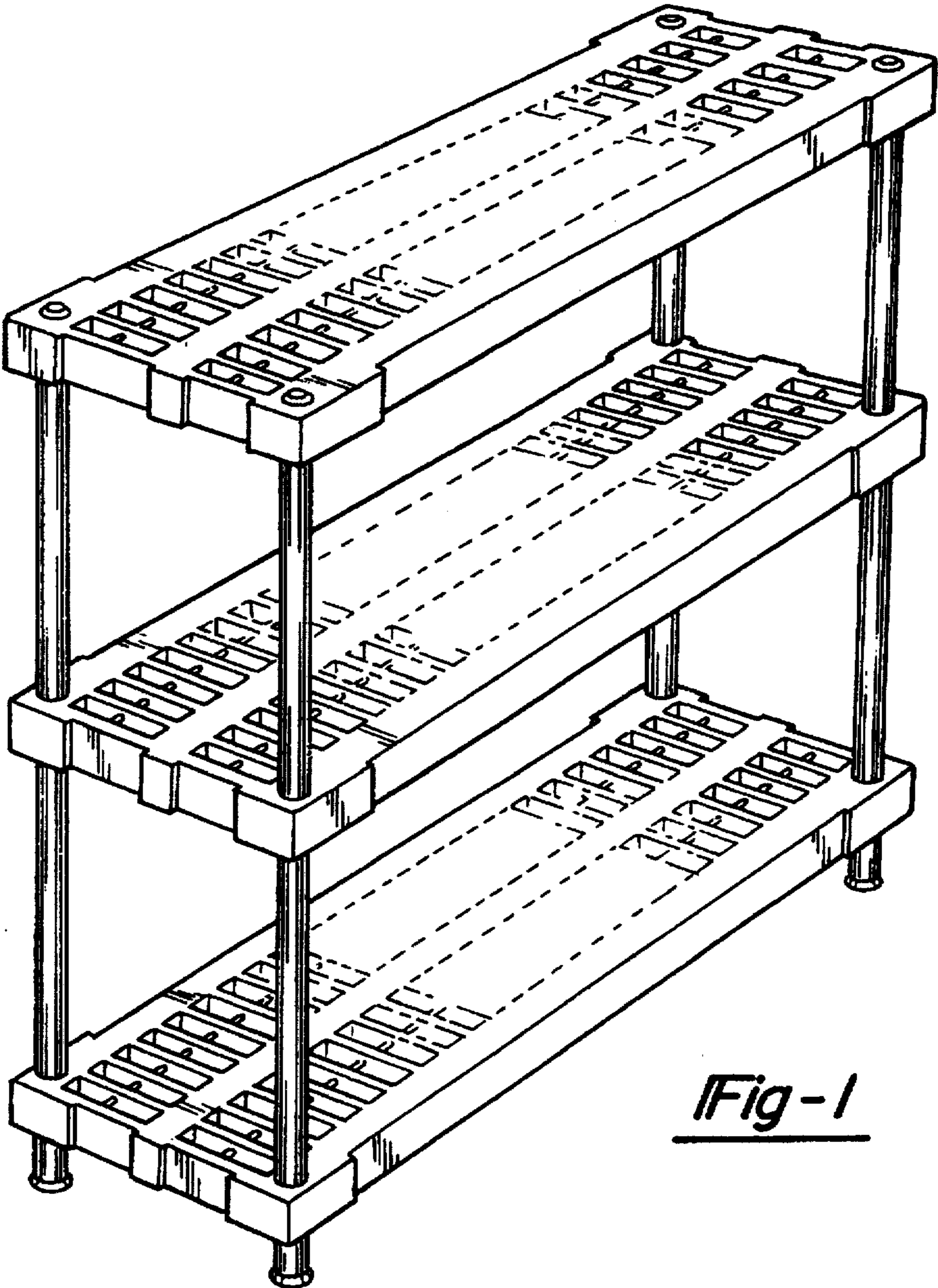

Fig-1

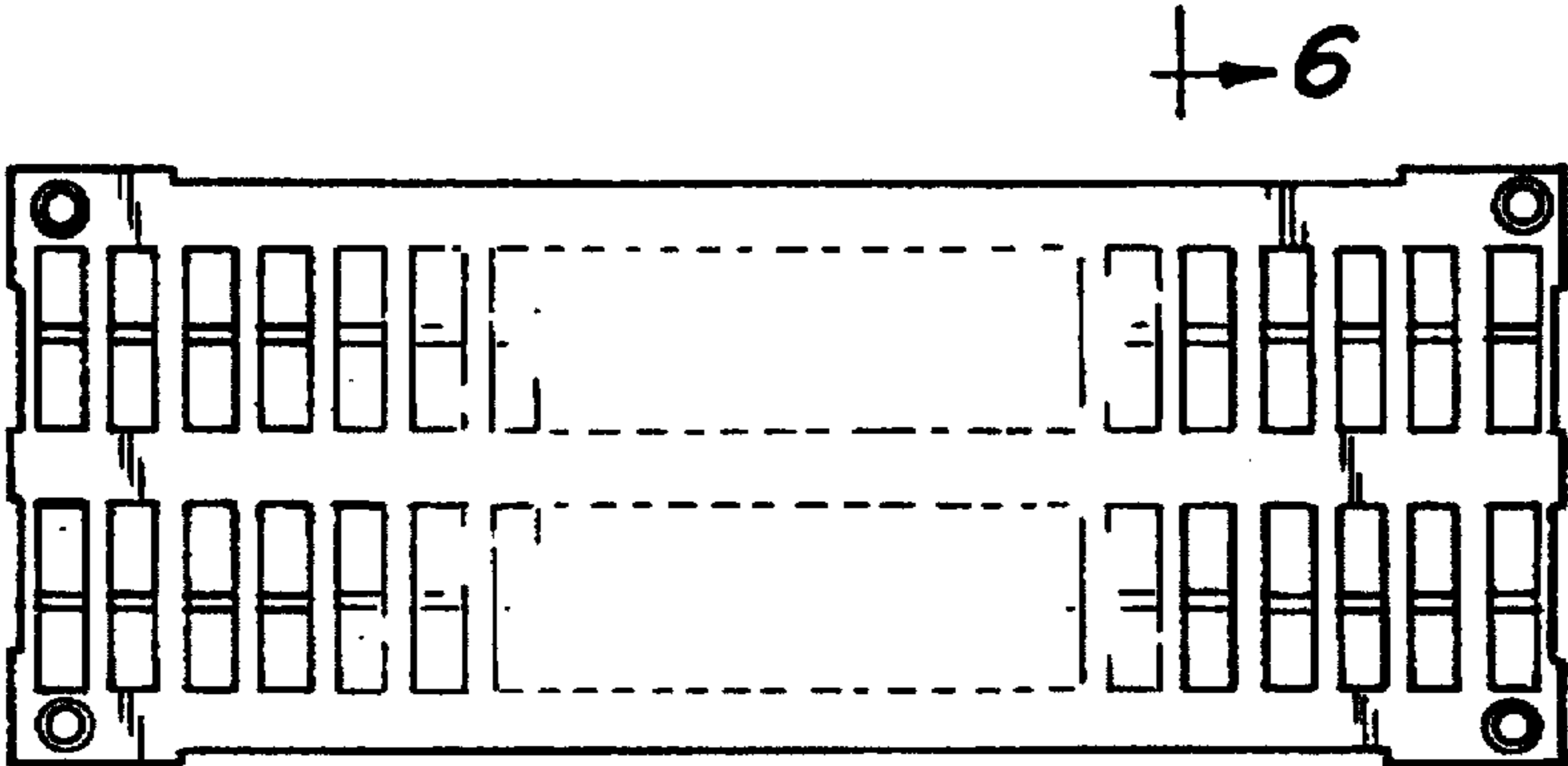

Fig-2

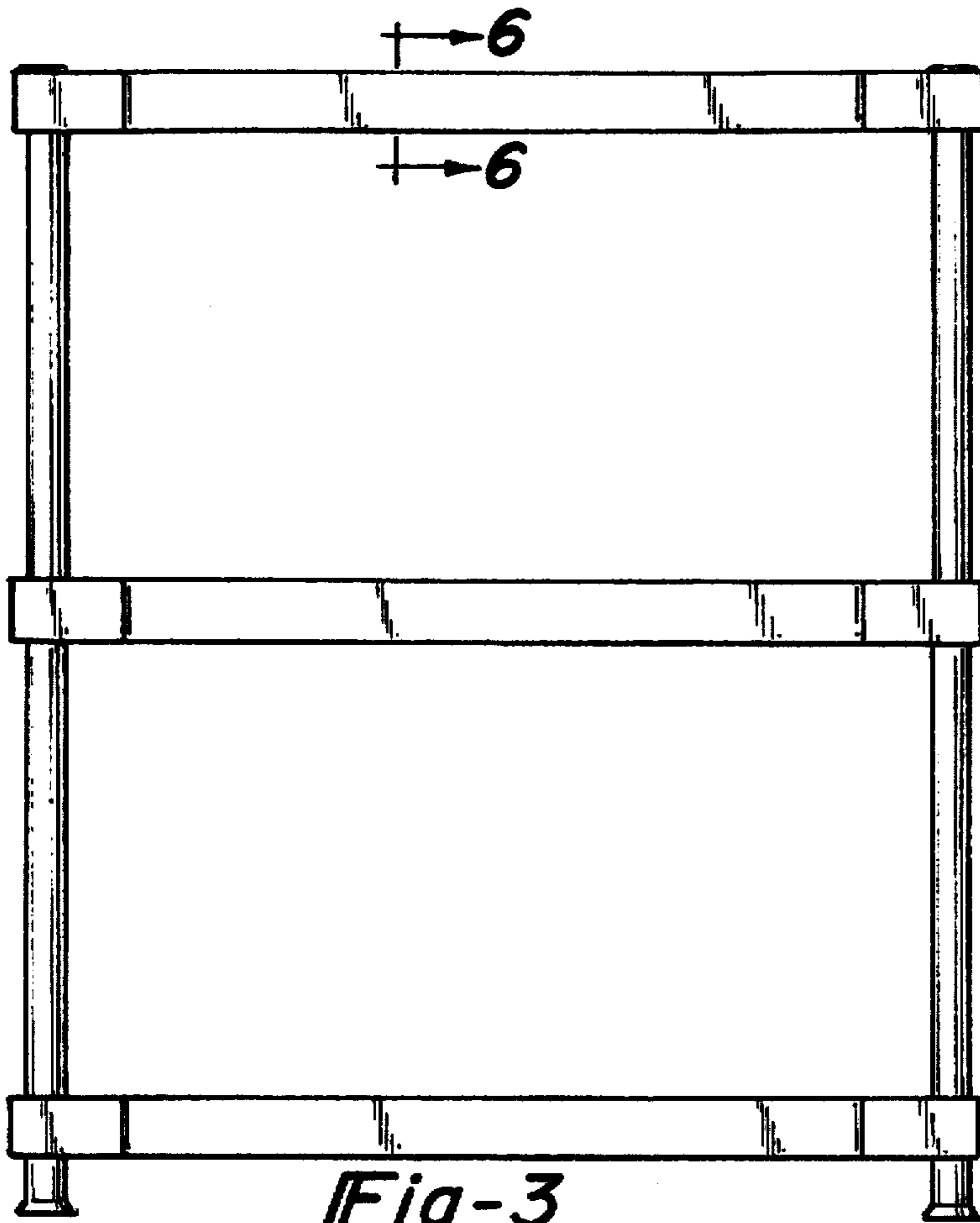

Fig-3

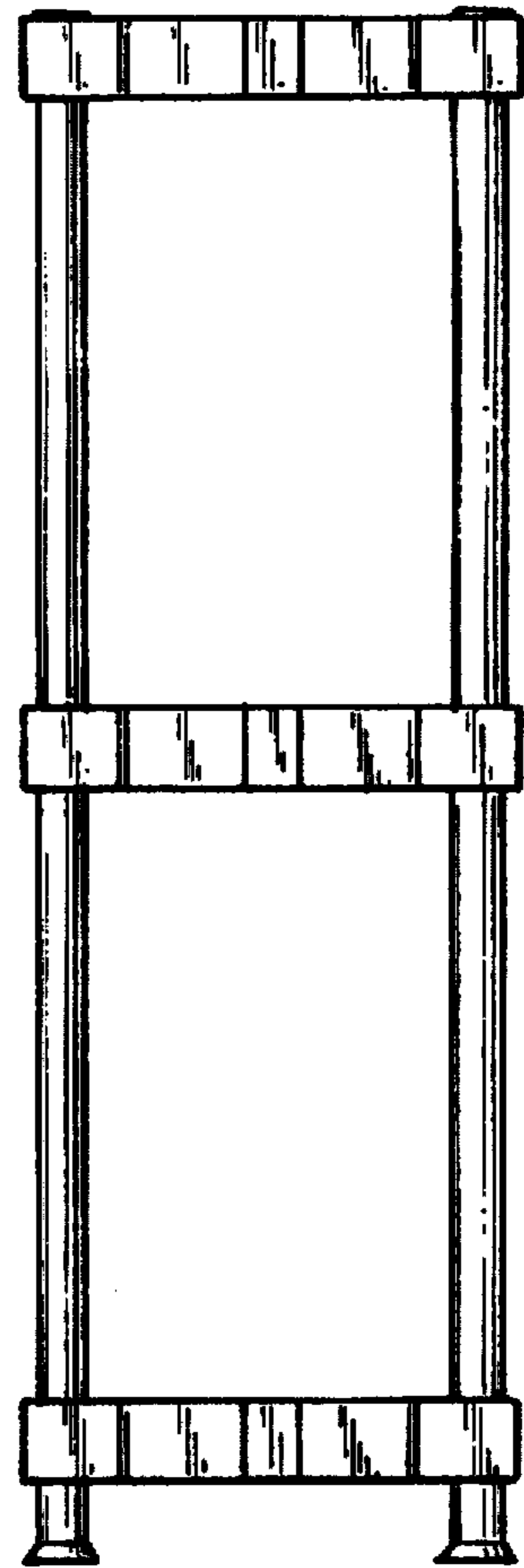

Fig-4

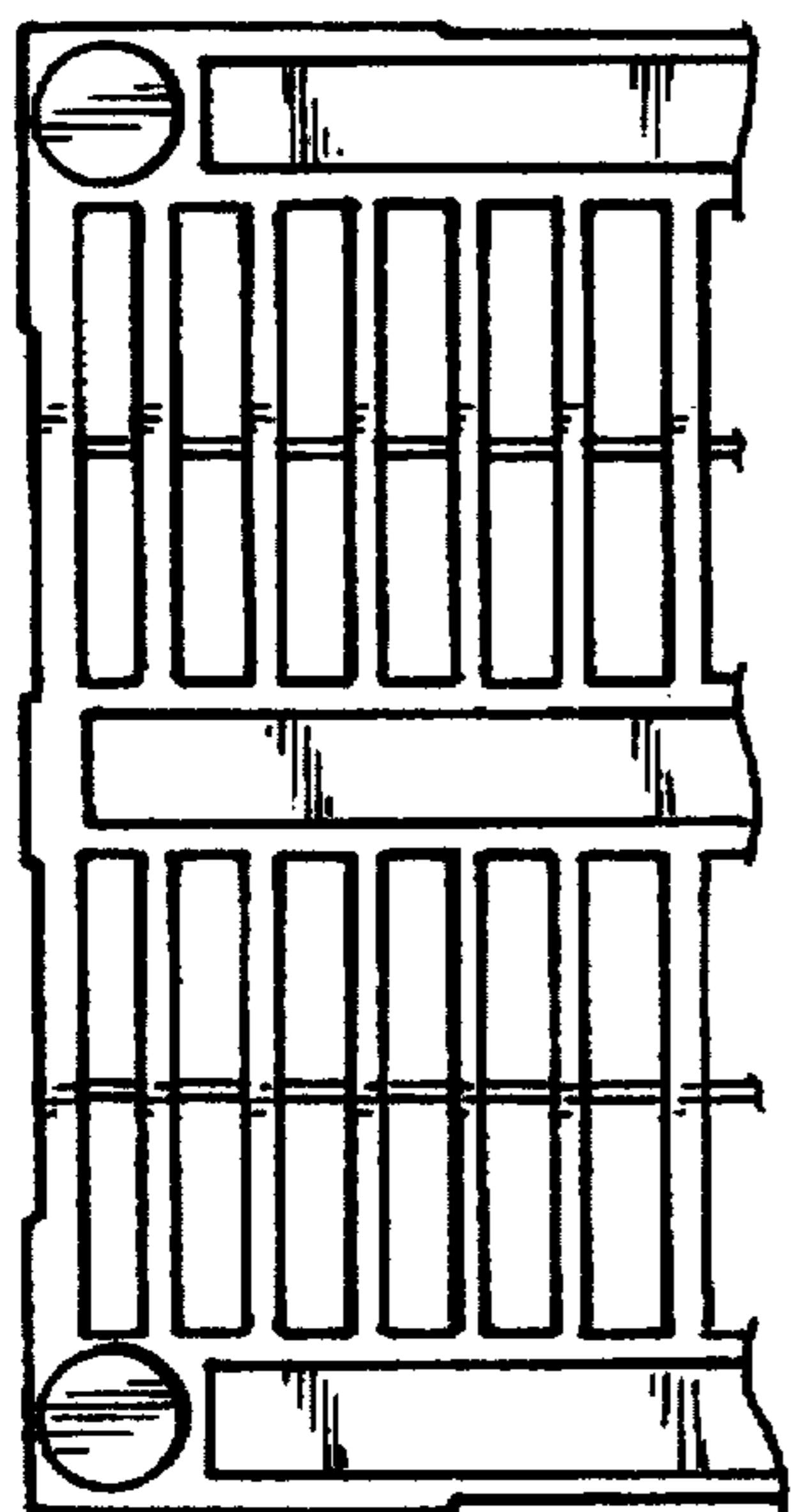

Fig-5



Fig-6

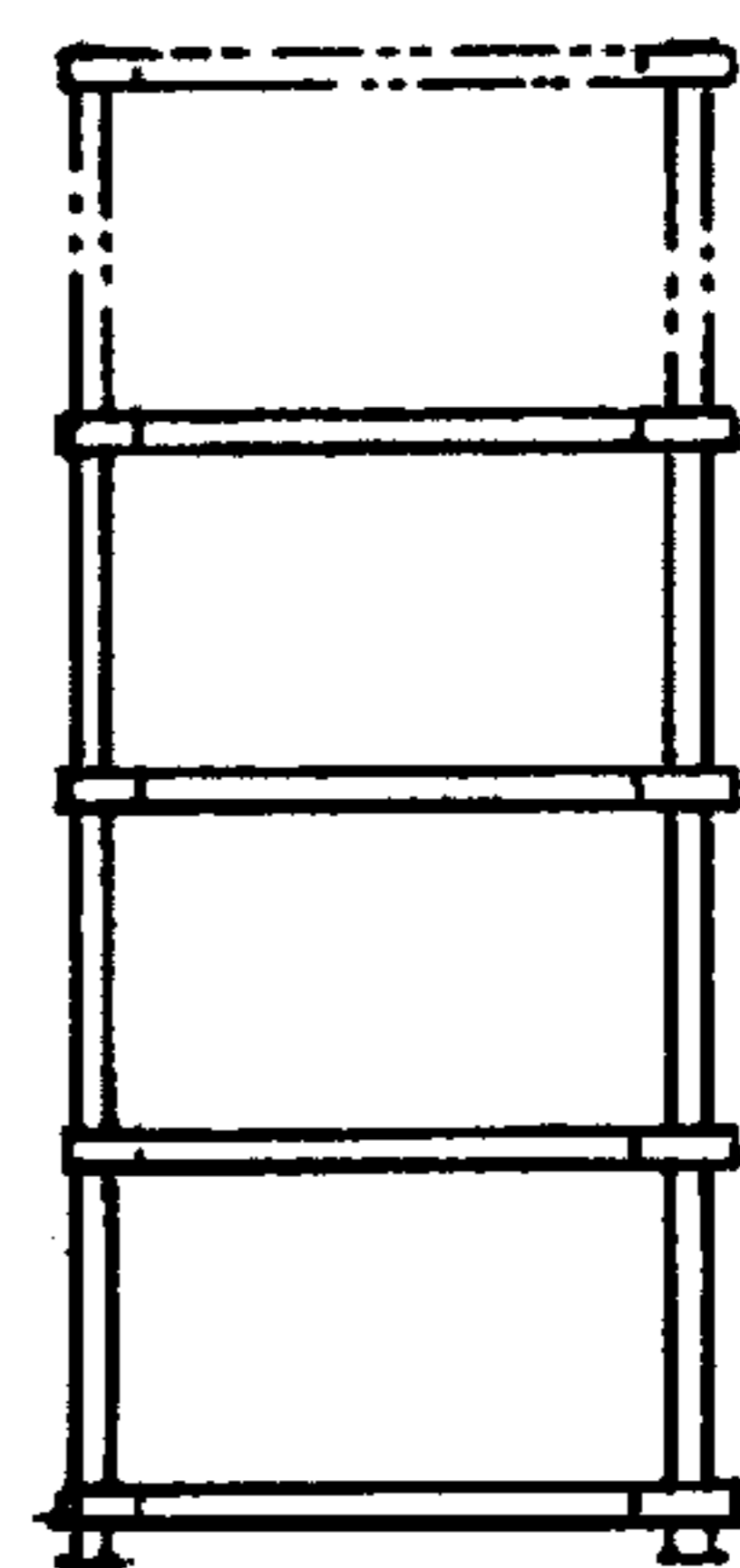

Fig-7