



US00D384959S

United States Patent [19]

[11] Patent Number: **Des. 384,959**

Kimbel et al.

[45] Date of Patent: ****Oct. 14, 1997**

[54] **AUTOMOTIVE FUEL SAVING AND POLLUTION CONTROL DEVICE**

[76] Inventors: **Andrew M. Kimbel**, 810-B N. 26th St., Philadelphia, Pa. 19130; **Joanne M. Jensen**, 1851 Canterbury Ave., Abington, Pa. 19601; **Robert Twardzik**, 1002 Newgate Dr., Allentown, Pa. 18103

[**] Term: **14 Years**

[21] Appl. No.: **34,219**

[22] Filed: **Jan. 31, 1995**

[51] LOC (6) Cl. **15-01**

[52] U.S. Cl. **D15/5**

[58] Field of Search **D15/5; 210/222, 210/223; 95/28; 96/1, 2**

[56] **References Cited**

U.S. PATENT DOCUMENTS

4,572,145	2/1986	Mitchell et al.	210/222	X
4,888,113	12/1989	Holcomb	210/222	
5,030,344	7/1991	Ambrose	96/1	X
5,254,247	10/1993	Kashani	96/1	X
5,558,765	9/1996	Twardzik	210/222	

Primary Examiner—Louis S. Zarfaz
Assistant Examiner—Frank Martinez
Attorney, Agent, or Firm—Klehr, Harrison, Harvey, Branzburg & Ellers

[57] **CLAIM**

The ornamental design for an automotive fuel saving and pollution control device, as shown and described.

DESCRIPTION

FIG. 1 is an isometric view of the automotive fuel saving and pollution control device of our new design;
FIG. 2 is a side view thereof, taken from one side of the device;
FIG. 3 is a side view thereof, taken from the opposite side of the device;
FIG. 4 is a top view thereof;
FIG. 5 is a bottom view thereof;
FIG. 6 is an end view thereof, taken from one end of the device; and,
FIG. 7 is an end view thereof, taken from the opposite side of the device.
The broken line showing of environment in FIGS. 1 to 7 is for illustrative purposes only and forms no part of the claimed design.

1 Claim, 4 Drawing Sheets

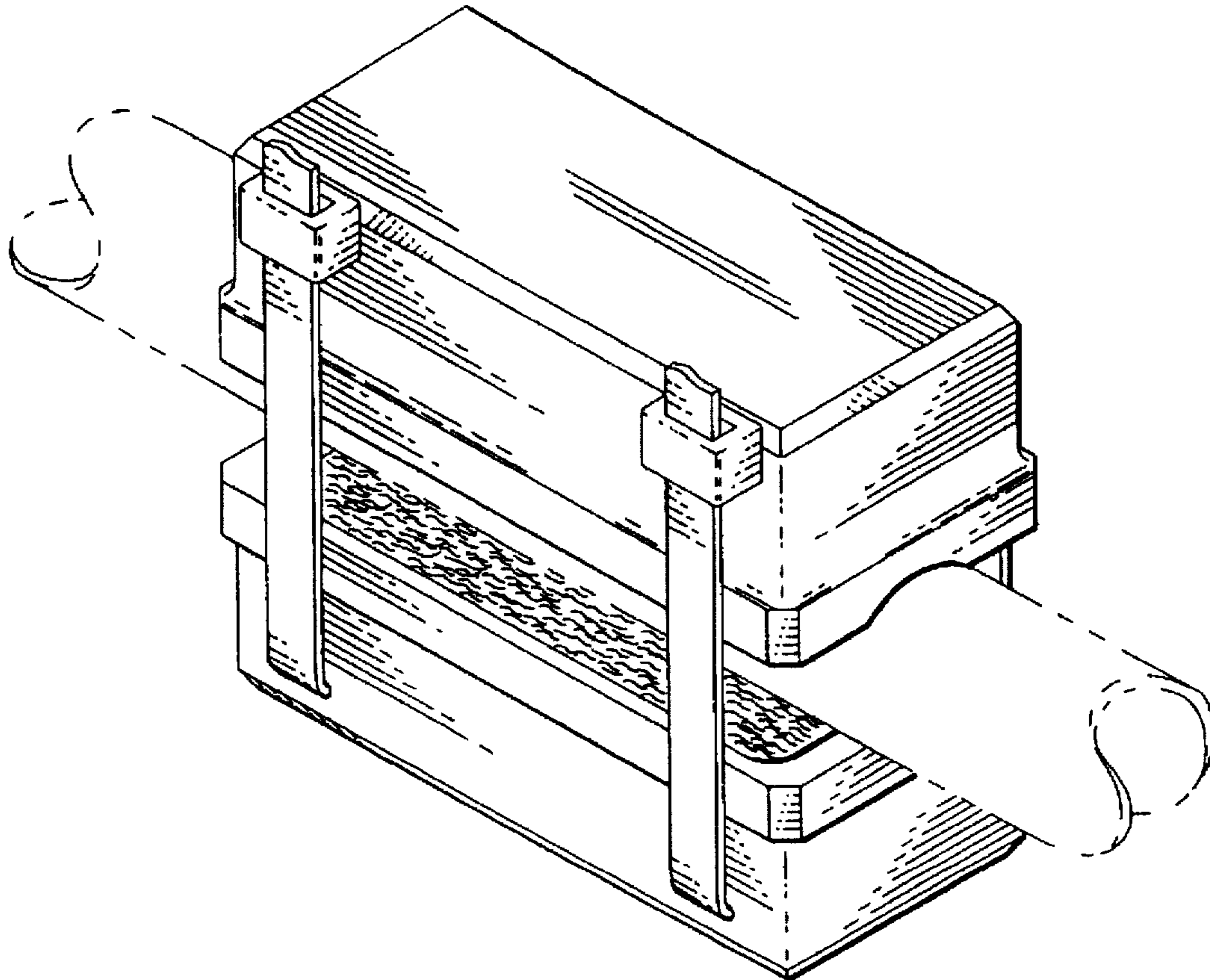

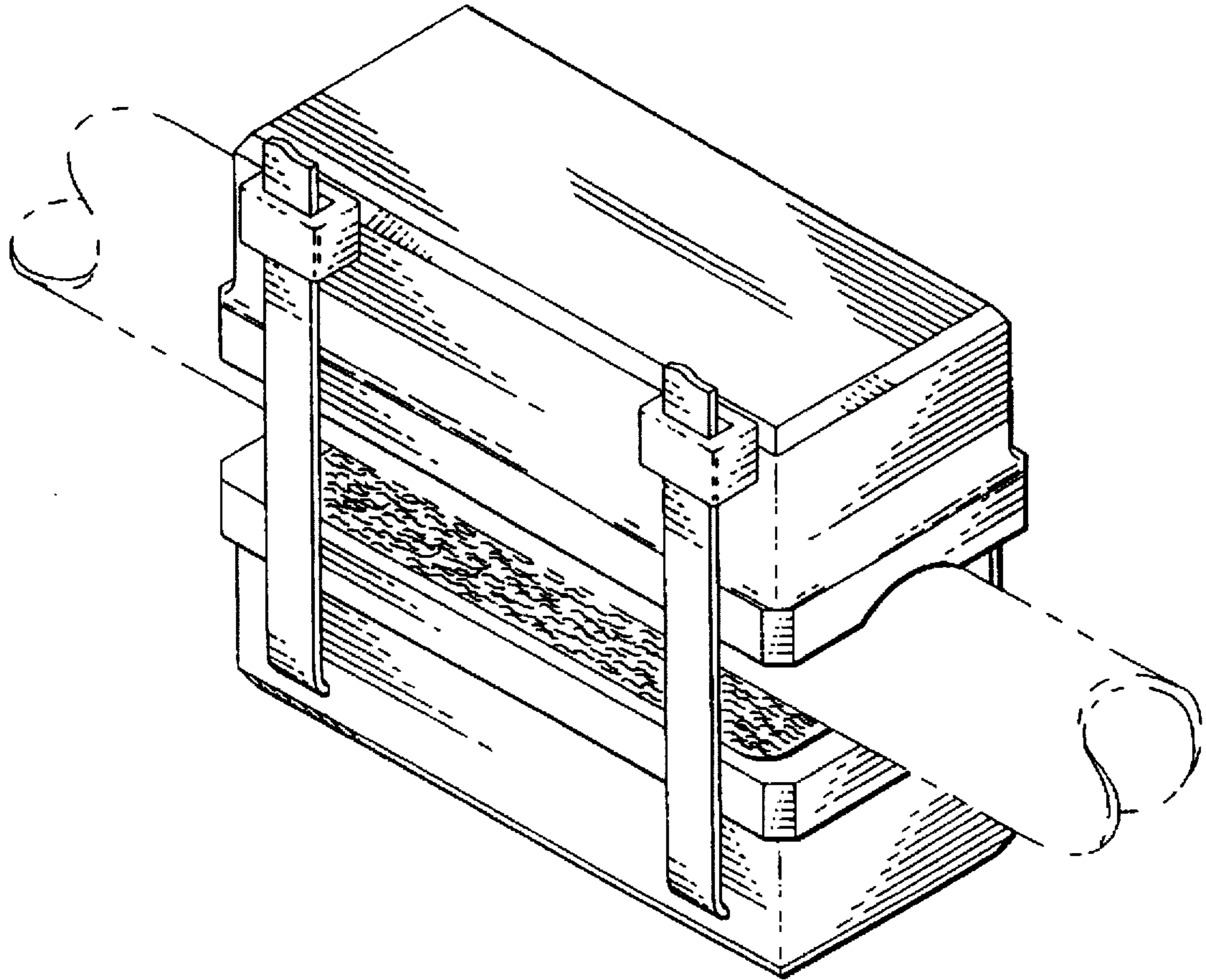

FIG. 1

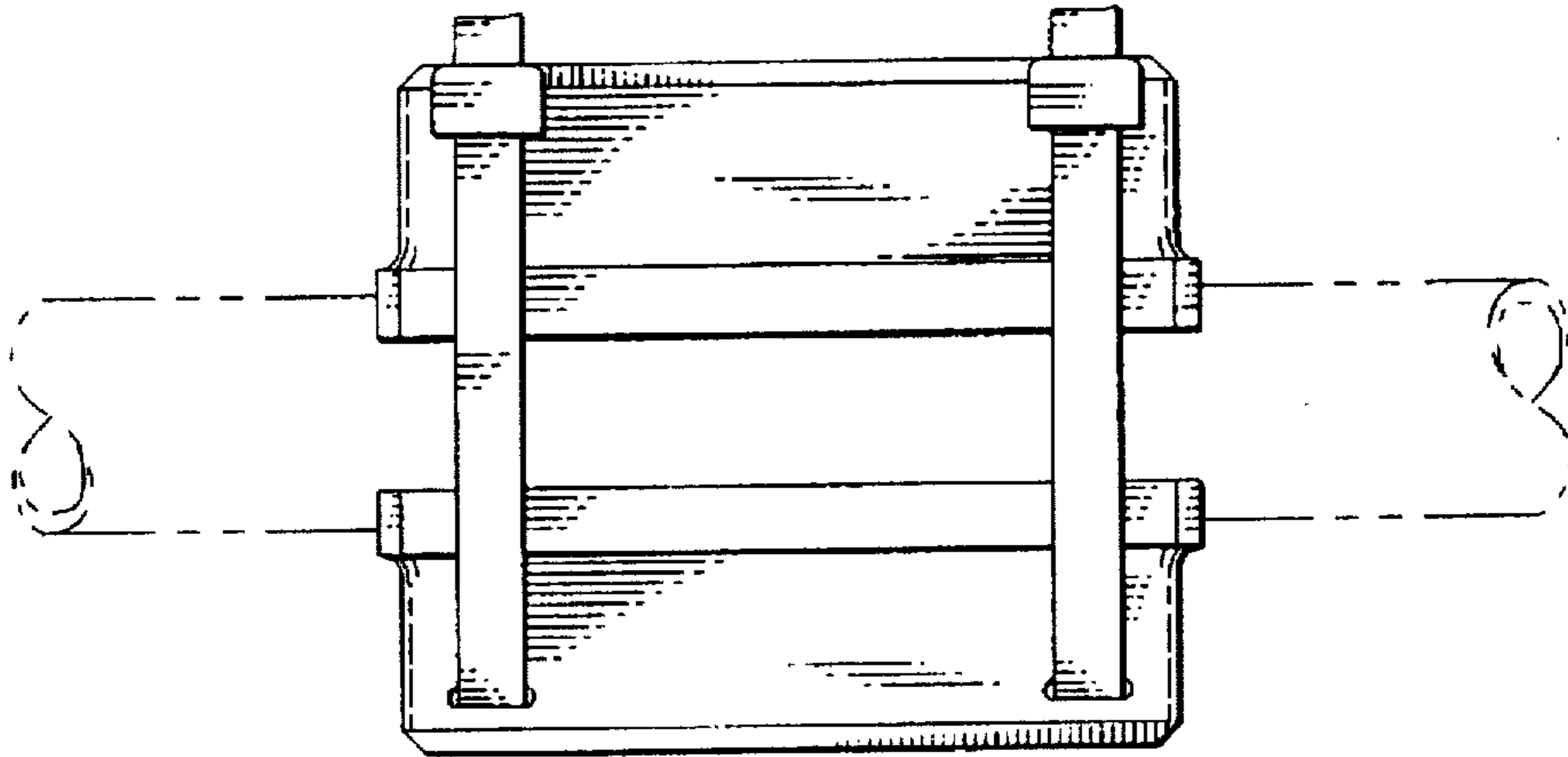

FIG. 2

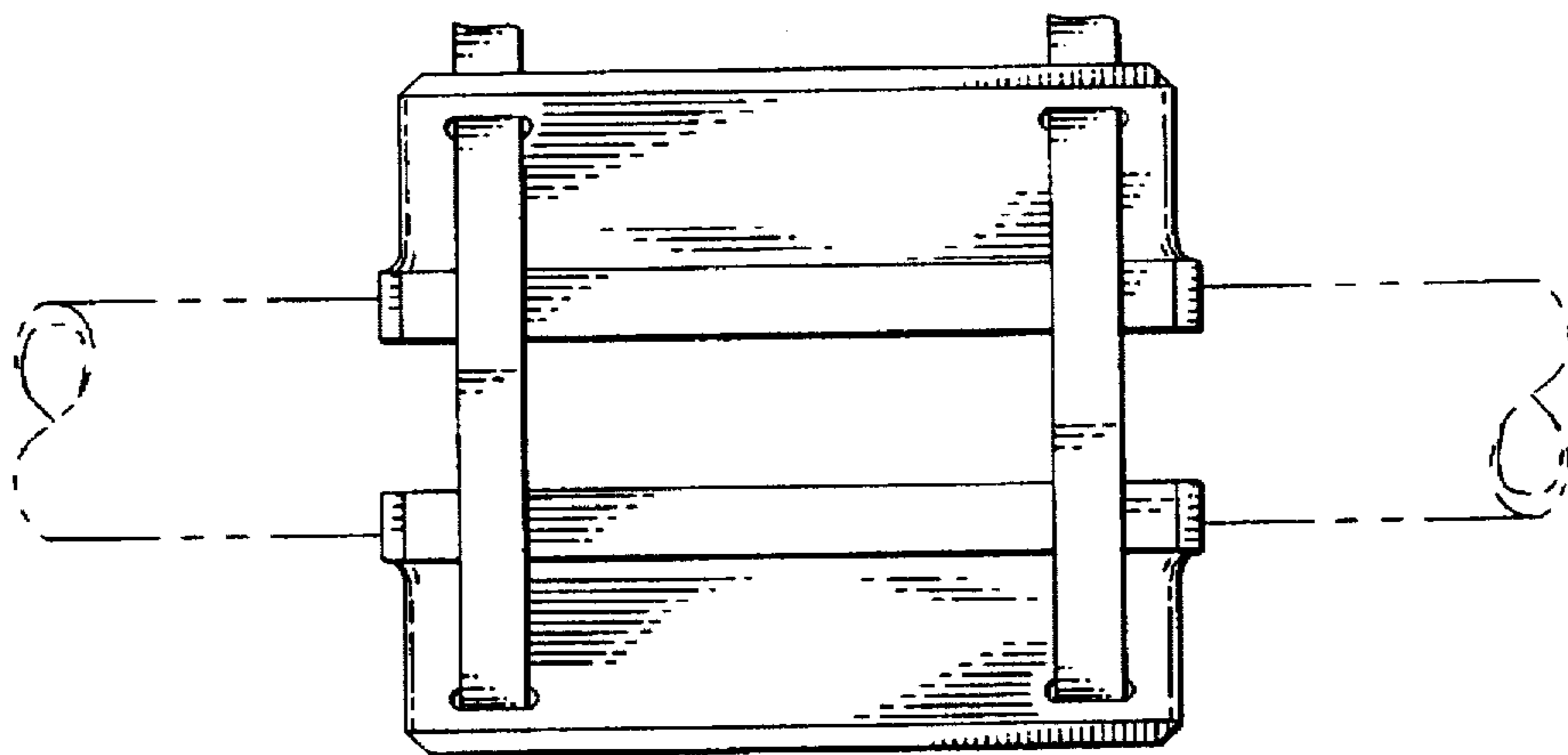

FIG. 3

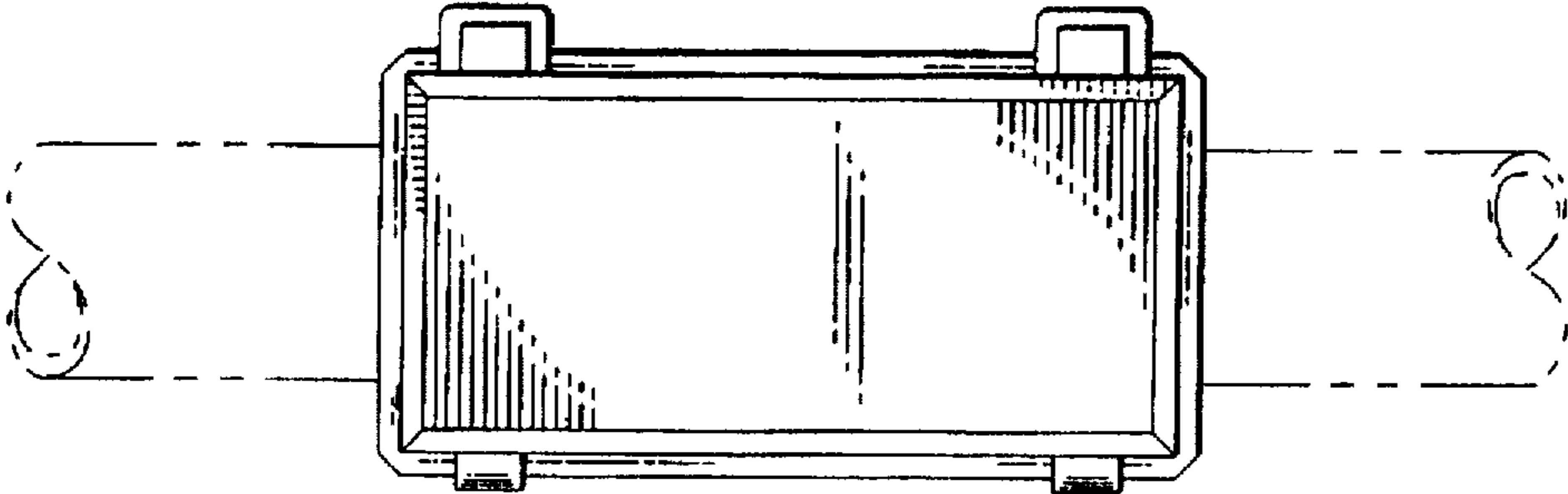

FIG. 5

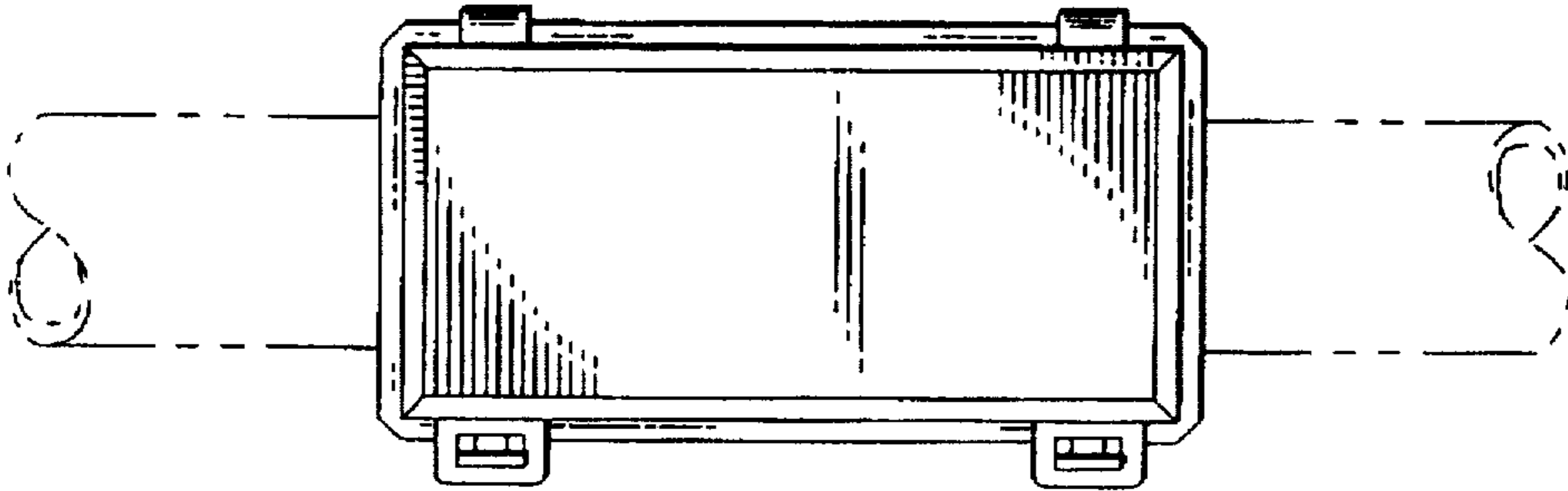

FIG. 4

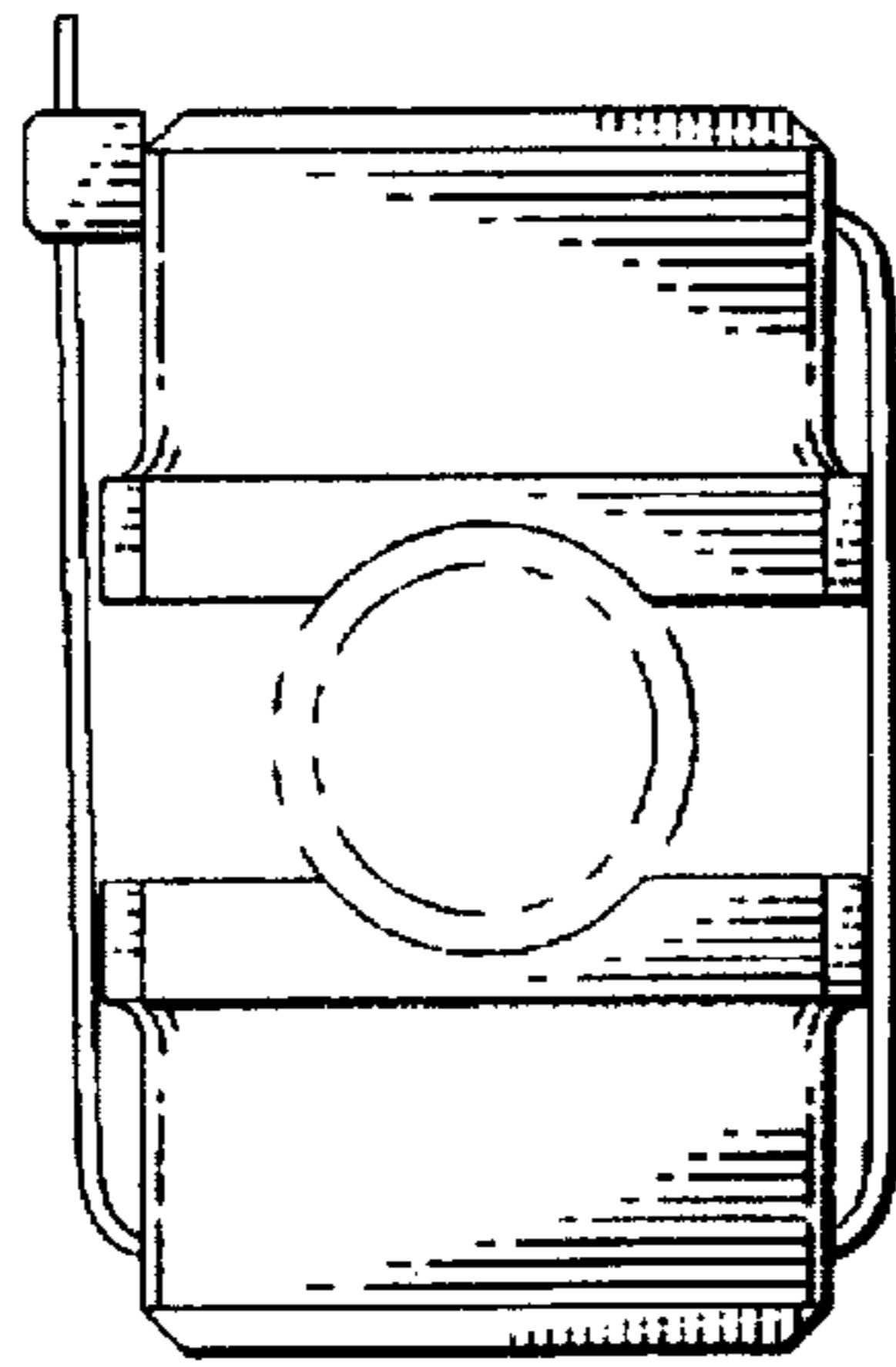

FIG. 6

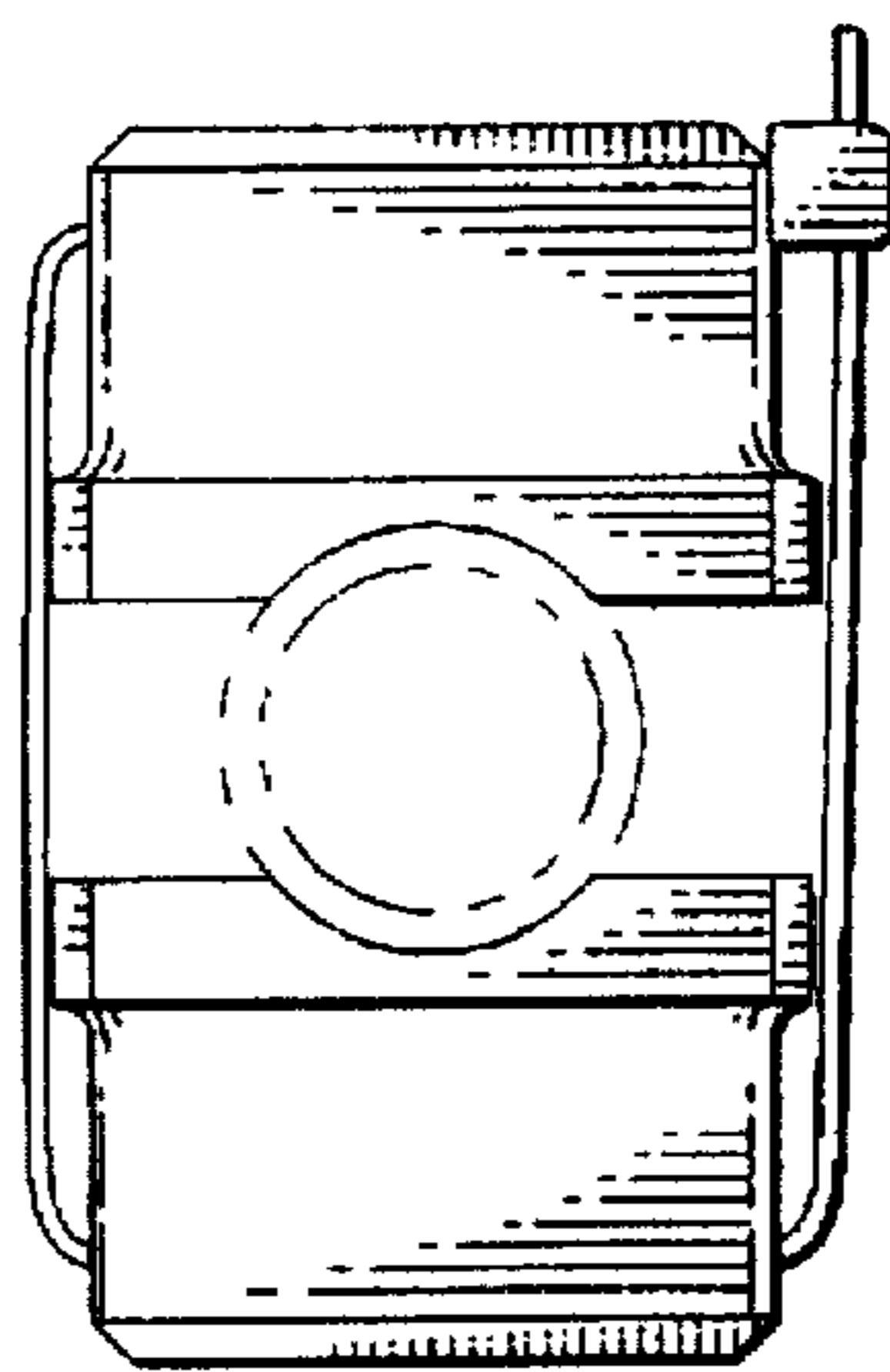

FIG. 7