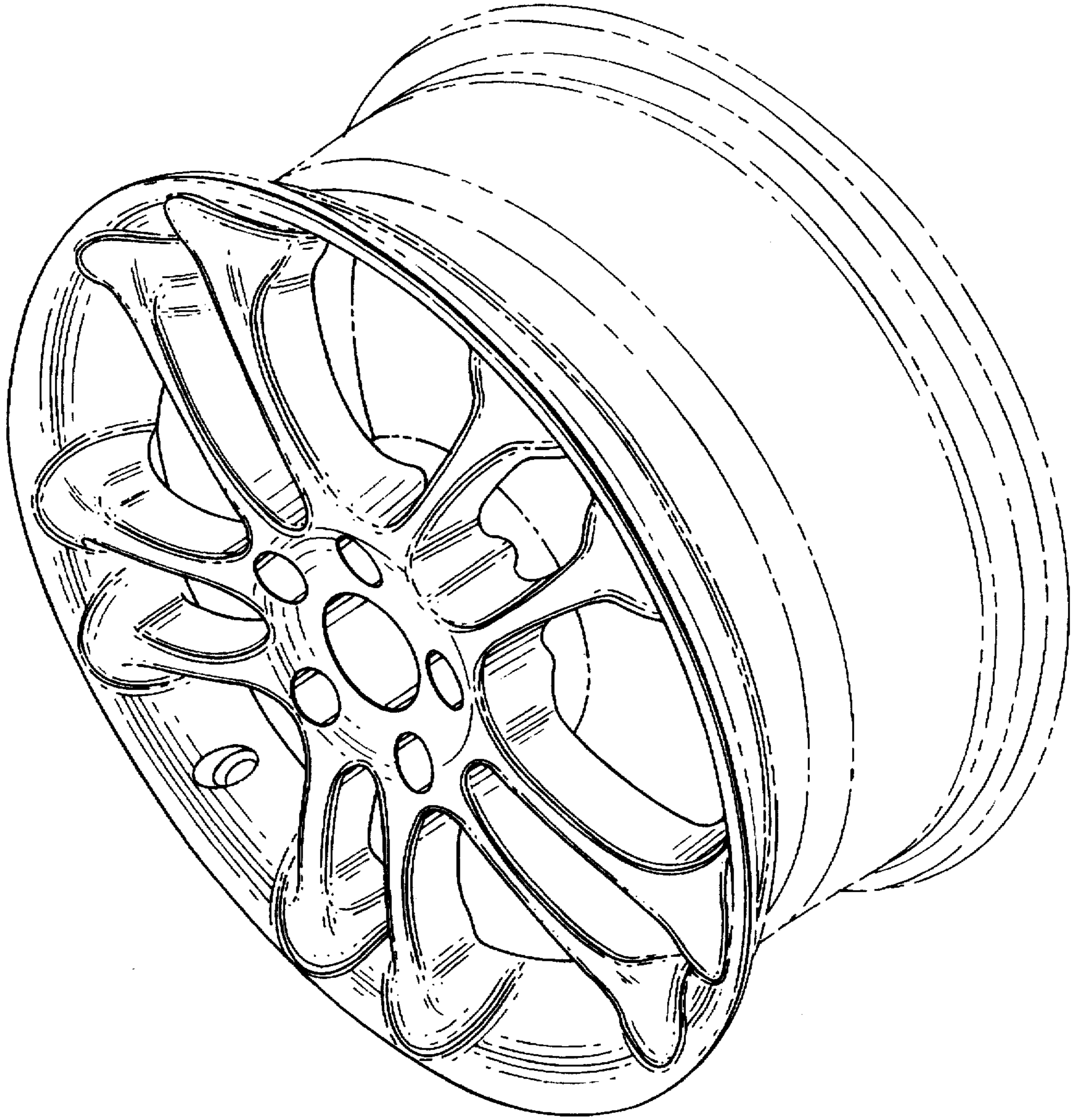



*Fig. 1*





*FIG. 2*

