



US00D384868S

**United States Patent** [19]  
**Farnham**

[11] **Patent Number:** **Des. 384,868**  
[45] **Date of Patent:** **\*\*Oct. 14, 1997**

[54] **SELF-IGNITING QUICK FIRE TORCH**

[75] **Inventor:** **Gilbert R. Farnham, Sycamore, Ill.**

[73] **Assignee:** **Cooper Industries, Inc., Houston, Tex.**

[\*\*] **Term:** **14 Years**

[21] **Appl. No.:** **57,938**

[22] **Filed:** **Aug. 5, 1996**

[51] **LOC (6) CL** ..... **08-05**

[52] **U.S. Cl.** ..... **D8/30; D15/144**

[58] **Field of Search** ..... **D15/144; D8/30,**  
**D8/29.1; 239/401, 579; 251/353, 354; 431/255,**  
**258, 264, 345**

[56] **References Cited**

**U.S. PATENT DOCUMENTS**

D. 302,097 7/1989 Spaulding et al. .... D8/30  
4,526,532 7/1985 Nelson ..... 431/255

*Primary Examiner*—Antoine Duval Davis  
*Attorney, Agent, or Firm*—Burns, Doane, Swecker & Mathis, L.L.P.

[57] **CLAIM**

The ornamental design for a self-igniting quick fire torch, as shown.

**DESCRIPTION**

FIG. 1 is a left side view of a self-igniting quick fire torch showing my new design;

FIG. 2 is an end view thereof;

FIG. 3 is a top view thereof;

FIG. 4 is a right side view thereof;

FIG. 5 is a bottom view thereof; and,

FIG. 6 is a front end view thereof.

**1 Claim, 2 Drawing Sheets**

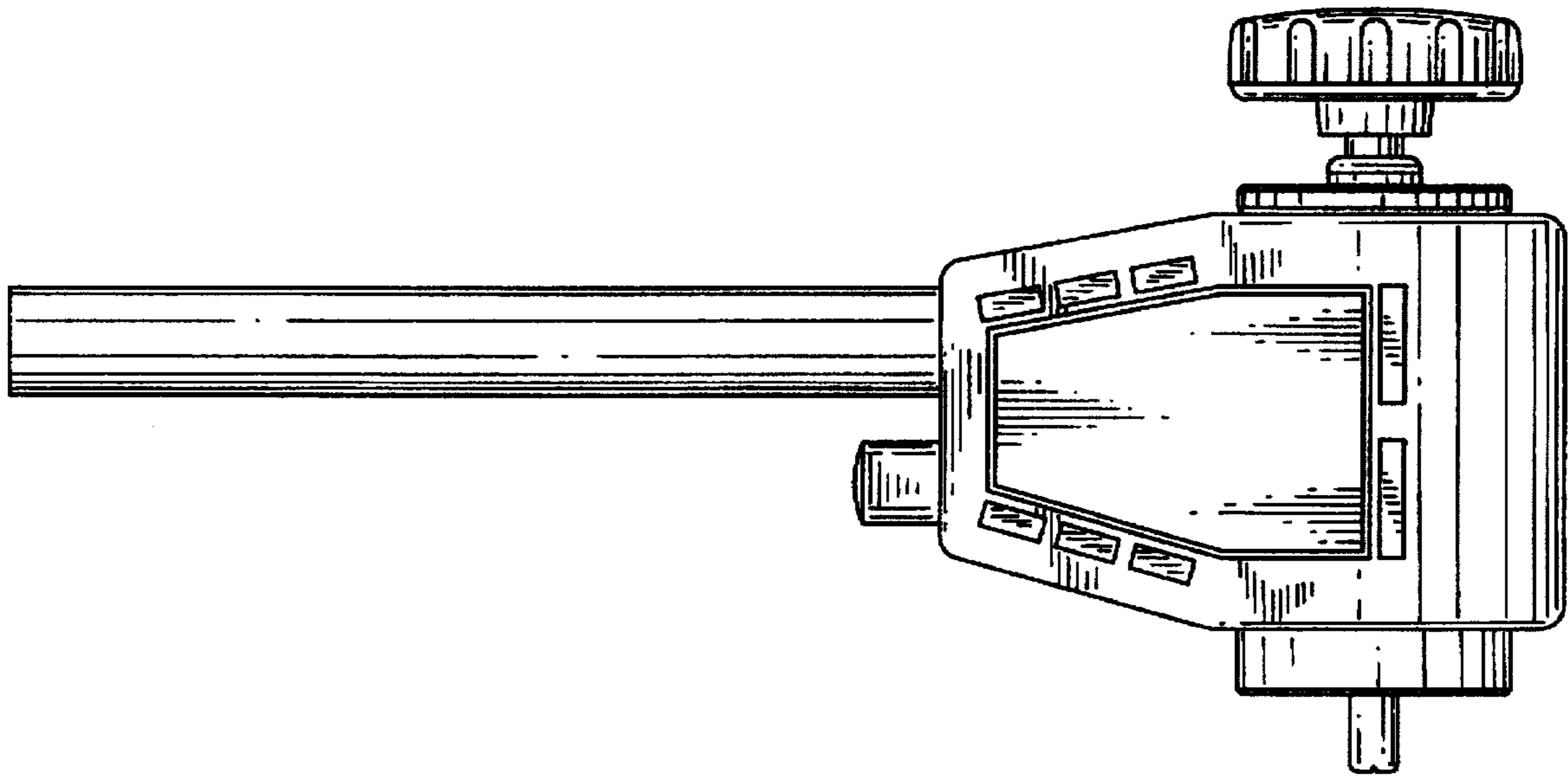

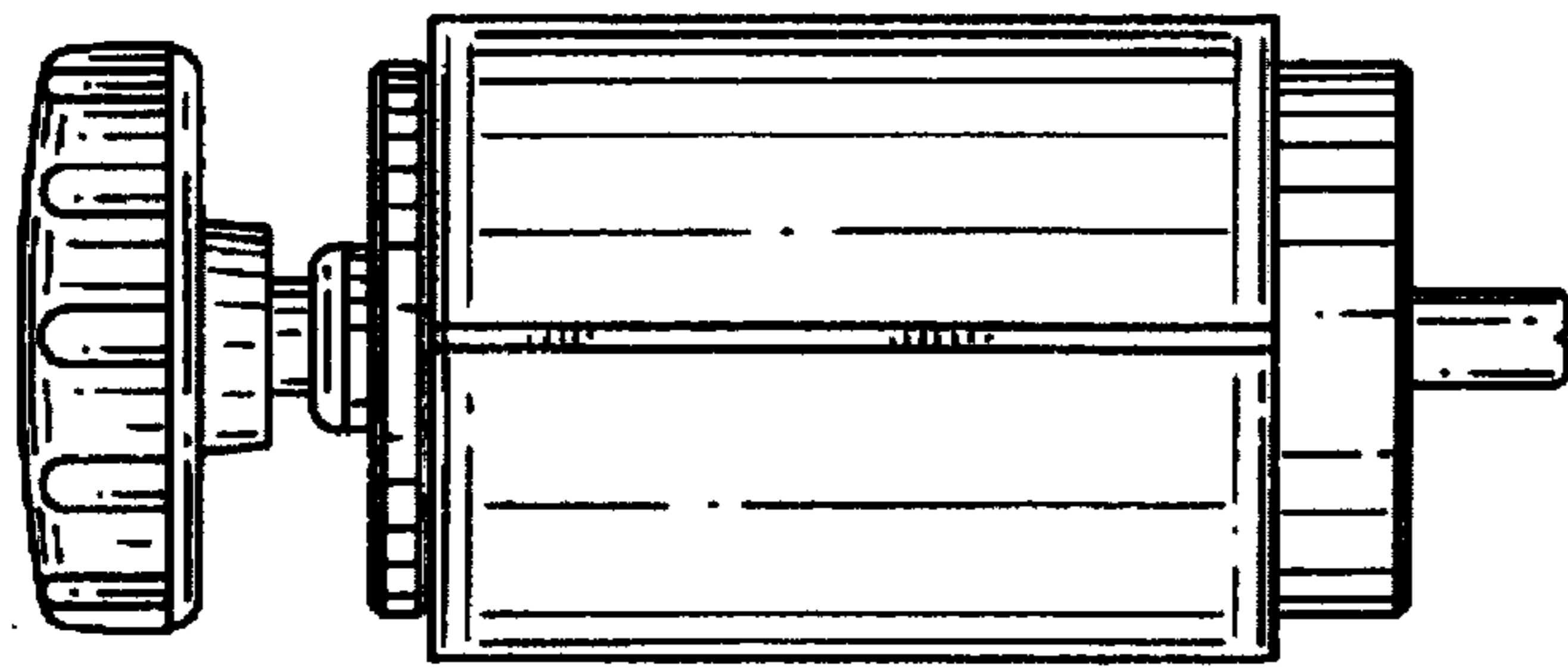

FIG. 2

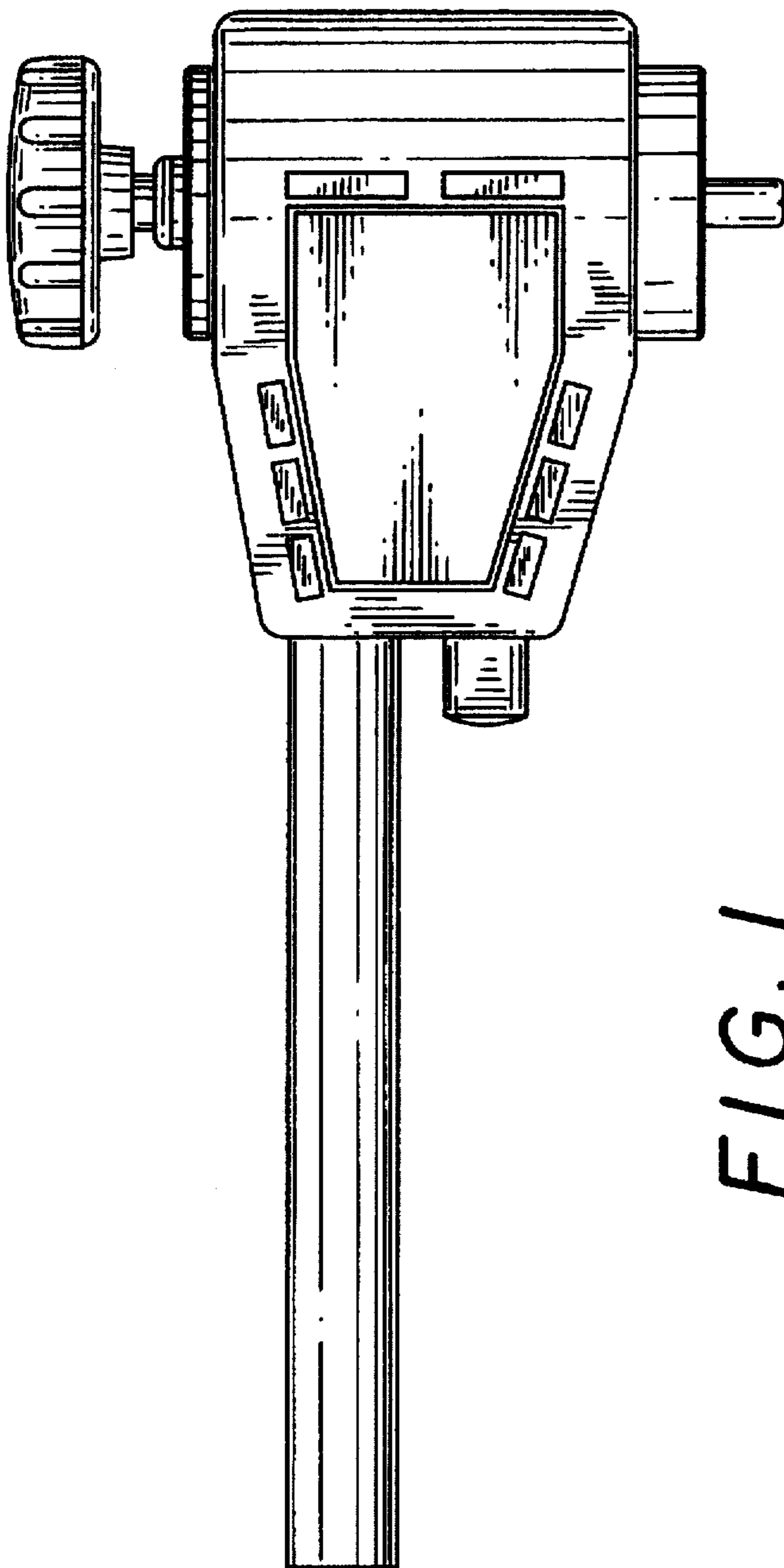

FIG. 1

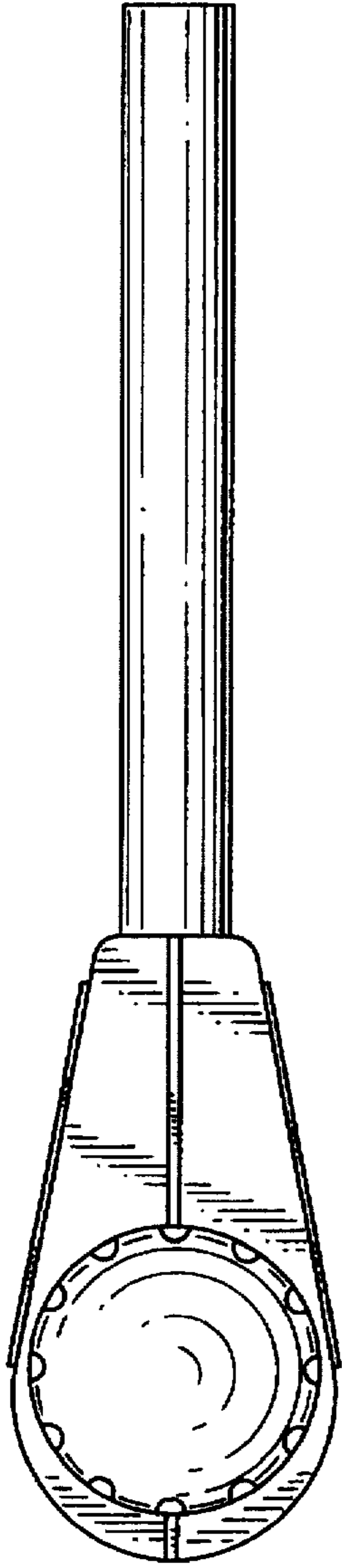

FIG. 3

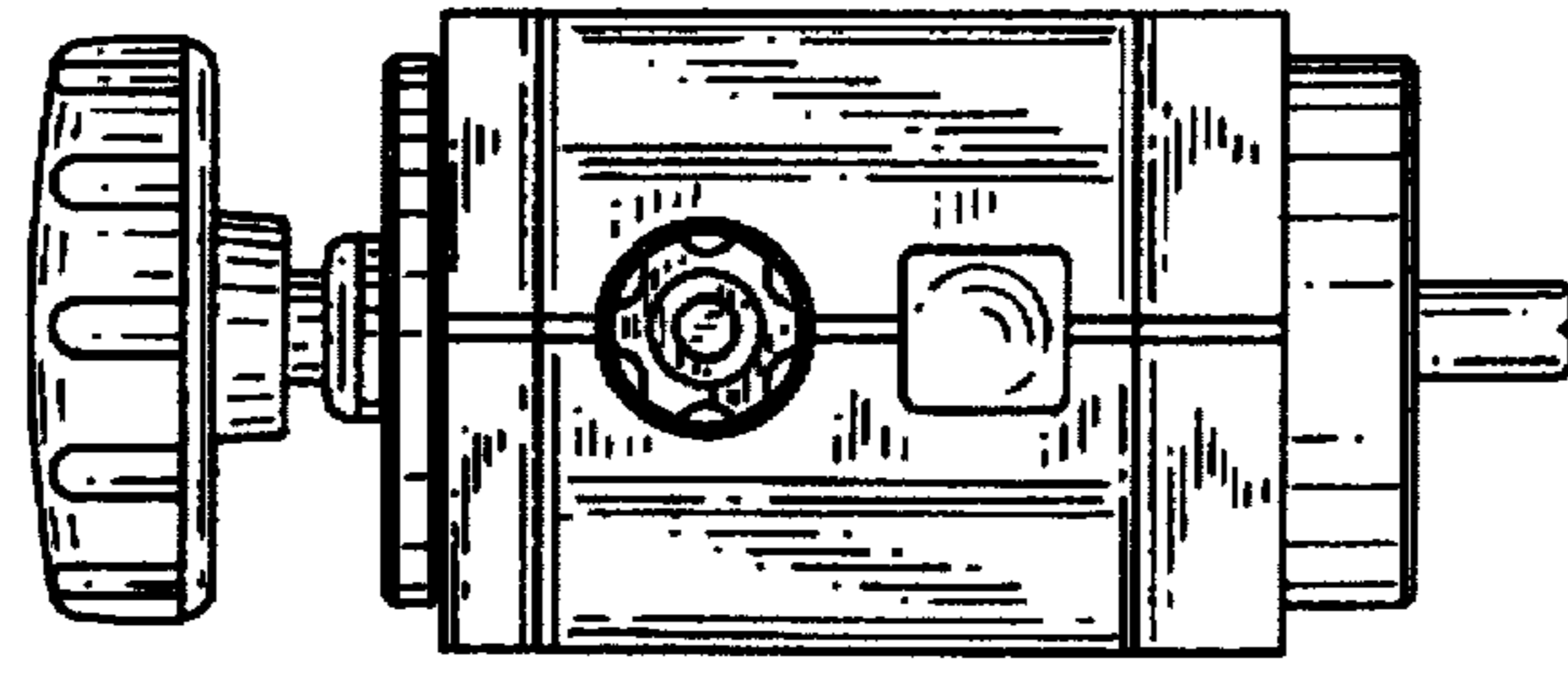

FIG. 6

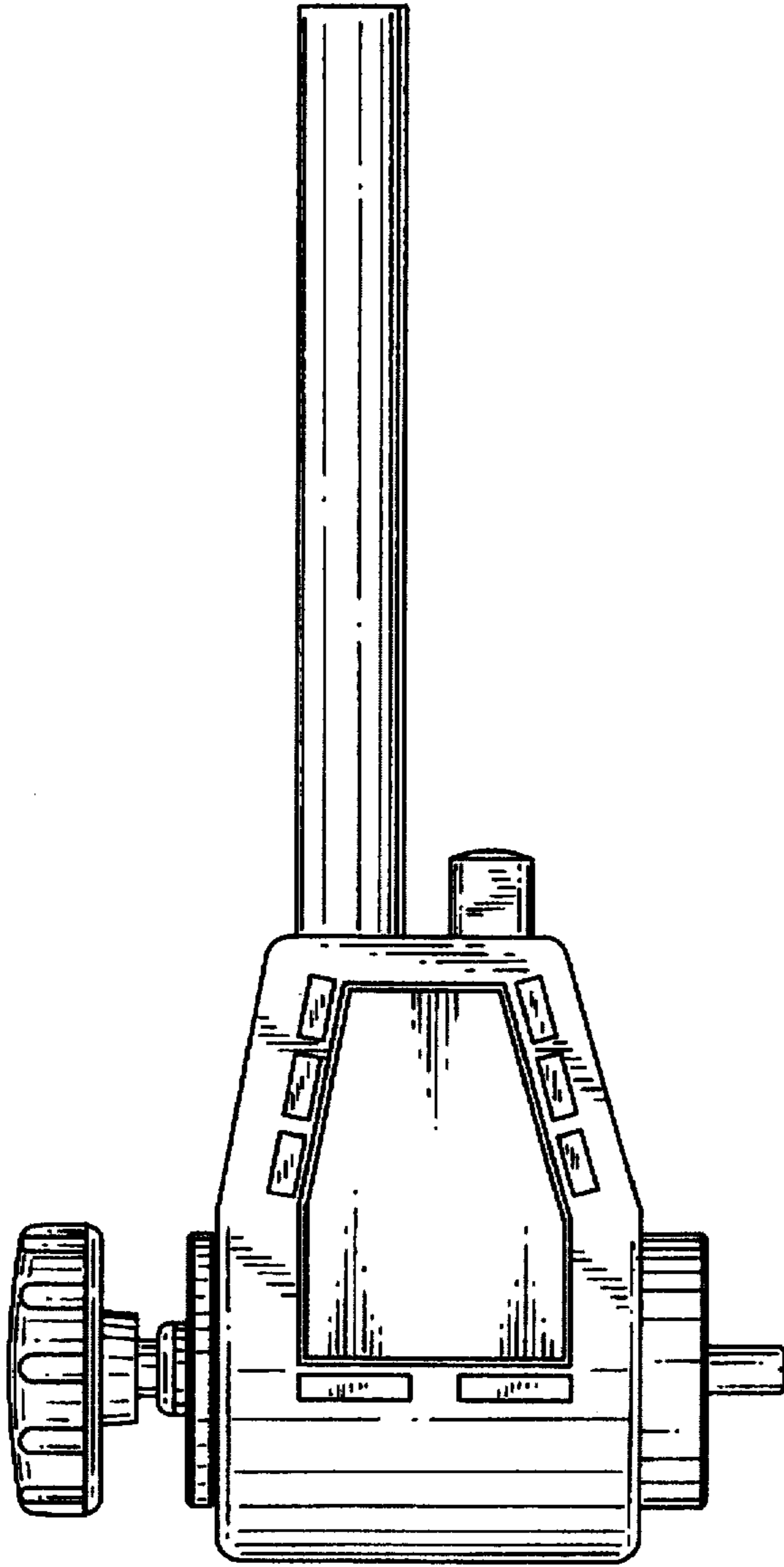

FIG. 4

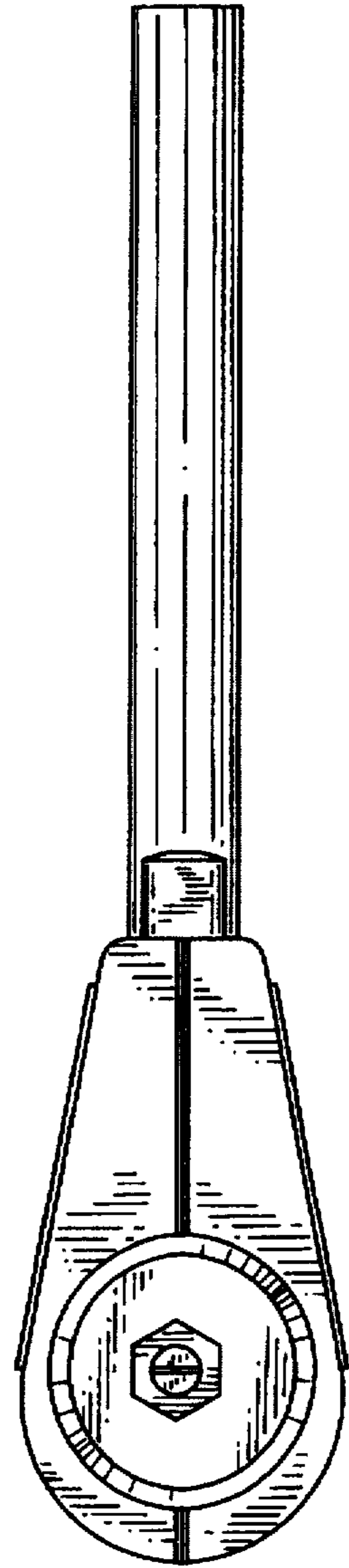

FIG. 5