

US00D384480S

**United States Patent** [19]  
**Patterson**

[11] **Patent Number: Des. 384,480**  
[45] **Date of Patent: \*\*Sep. 30, 1997**

[54] **COMBINED TOWING BOOM AND STABILIZER FOR WATERBORNE BOAT**

[76] **Inventor: Mark S. Patterson, 2525 Sabre Ct. - Apt. B, Redding, Calif. 96002**

[\*\*] **Term: 14 Years**

[21] **Appl. No.: 52,388**

[22] **Filed: Mar. 28, 1996**

[51] **LOC (6) Cl. .... 12-05**

[52] **U.S. Cl. .... D34/36; D34/33**

[58] **Field of Search .... D34/28, 33, 35, D34/36; 280/47.331; 414/563; 254/79.3, 4 R, 325, 266; 212/176, 177**

[56] **References Cited**

**U.S. PATENT DOCUMENTS**

D. 301,127	5/1989	Lindblom	.....	D34/36
D. 341,242	11/1993	Thorby	.....	D34/28
D. 358,696	5/1995	Mims	.....	D34/28
3,861,534	1/1975	Birdwell	.....	212/176
4,463,858	8/1984	Bilas	.....	212/176
4,727,995	3/1988	Louw	.....	D34/35
5,211,124	5/1993	Reiser	.....	D34/28

5,281,078 1/1994 Mills ..... 414/563

*Primary Examiner*—A. Hugo Word  
*Assistant Examiner*—Robin V. Taylor  
*Attorney, Agent, or Firm*—Lothrop & West

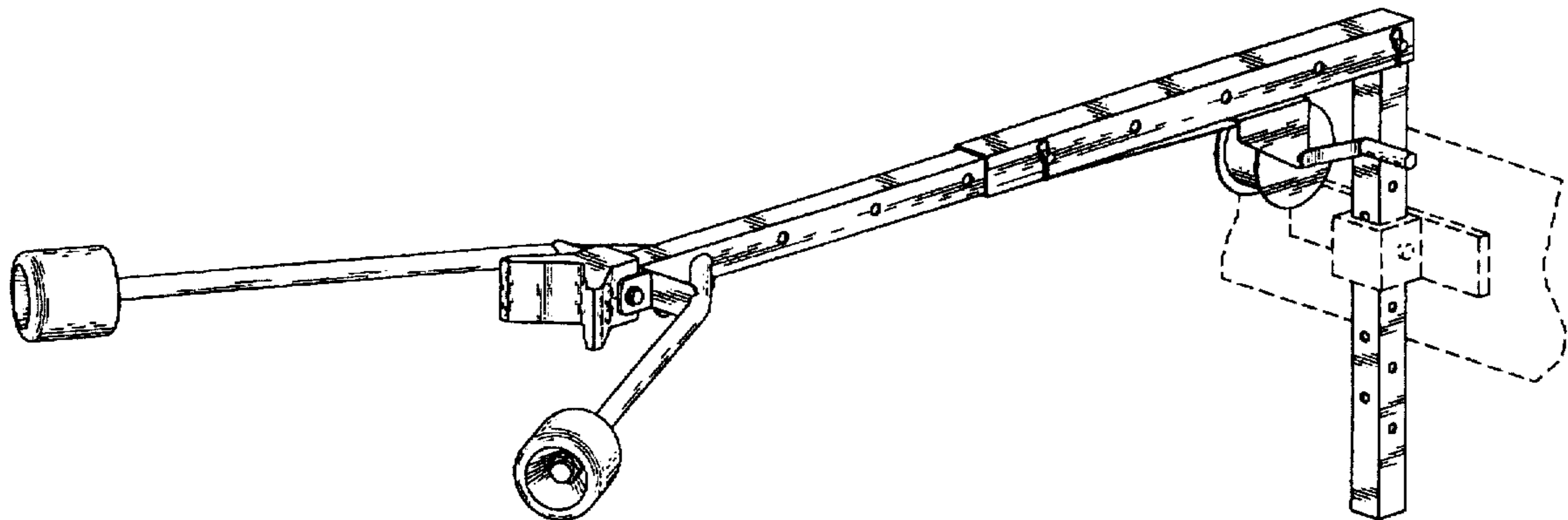
[57] **CLAIM**

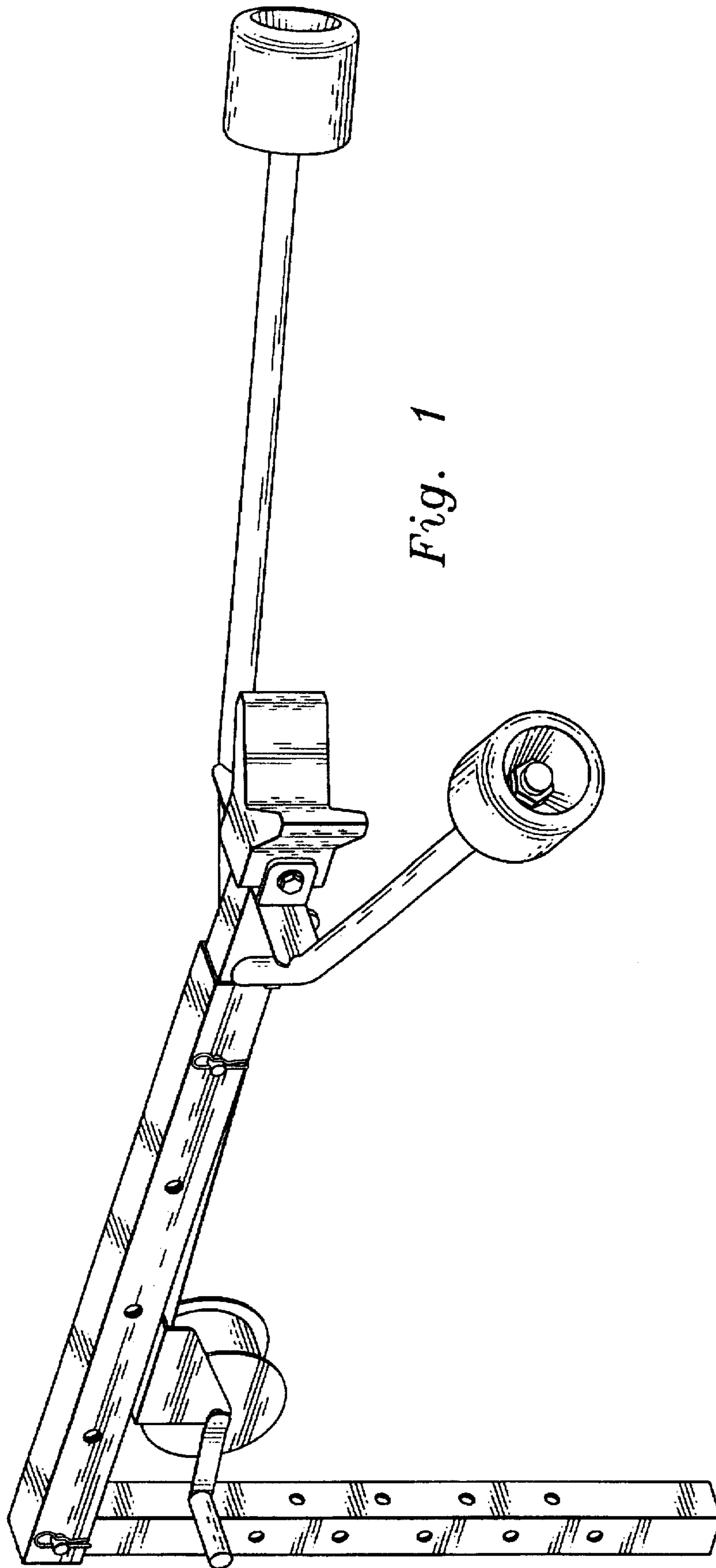
The ornamental design for a combined towing boom and stabilizer for waterborne boat, as shown and described.

**DESCRIPTION**

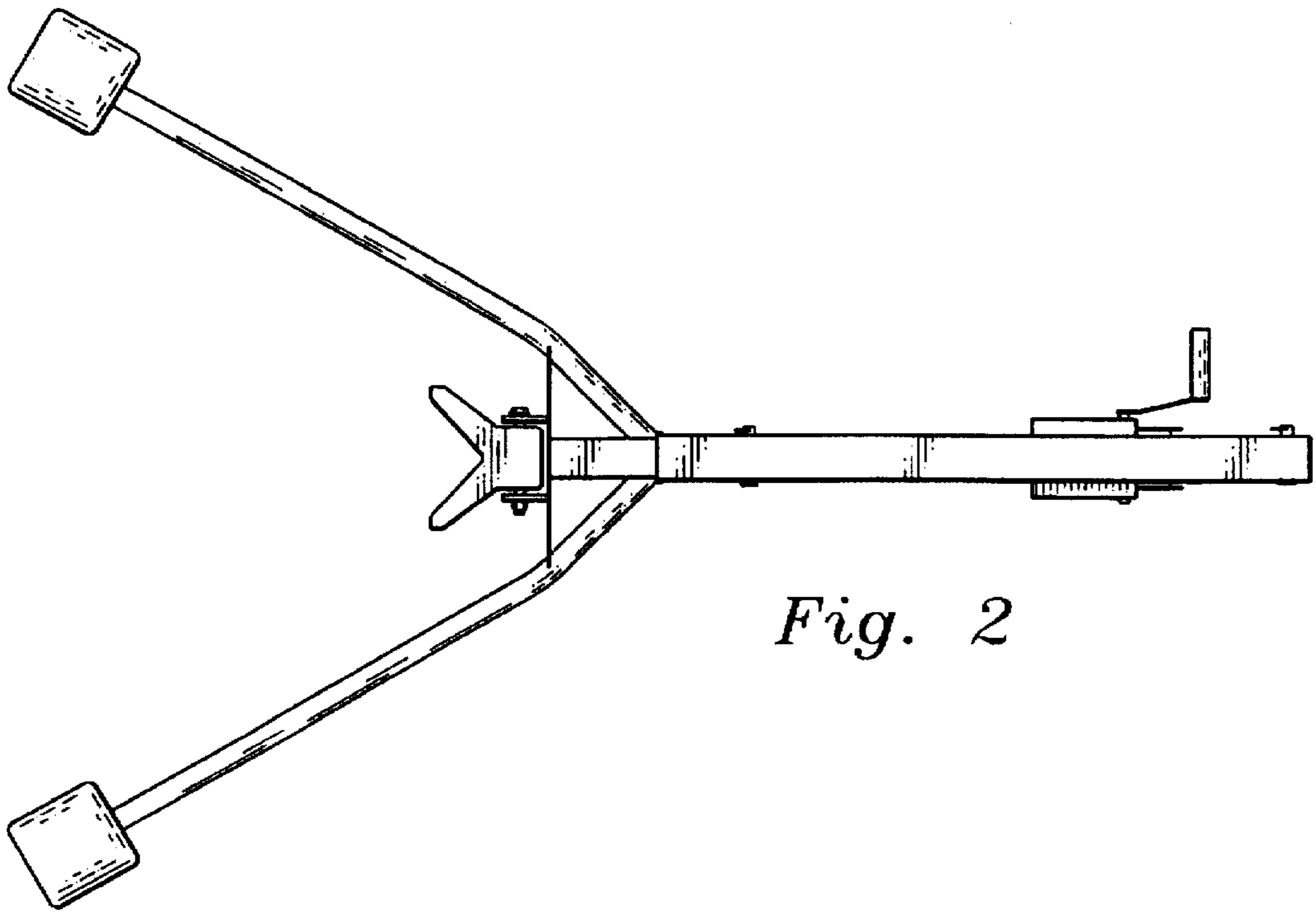
FIG. 1 is a right rear perspective view of a combined towing boom and stabilizer for waterborne boat, showing my new design;  
FIG. 2 is a top plan view;  
FIG. 3 is a left side elevation;  
FIG. 4 is a rear elevation;  
FIG. 5 is a bottom plan view;  
FIG. 6 is a right side elevation;  
FIG. 7 is a front elevation;  
FIG. 8 is a right side elevation with the winch hook extended for engagement with the towed boat; and,  
FIG. 9 is a left rear perspective view.  
The broken lines in FIGS. 8 and 9 merely illustrate the environment and form no part of the claimed design.

**1 Claim, 4 Drawing Sheets**

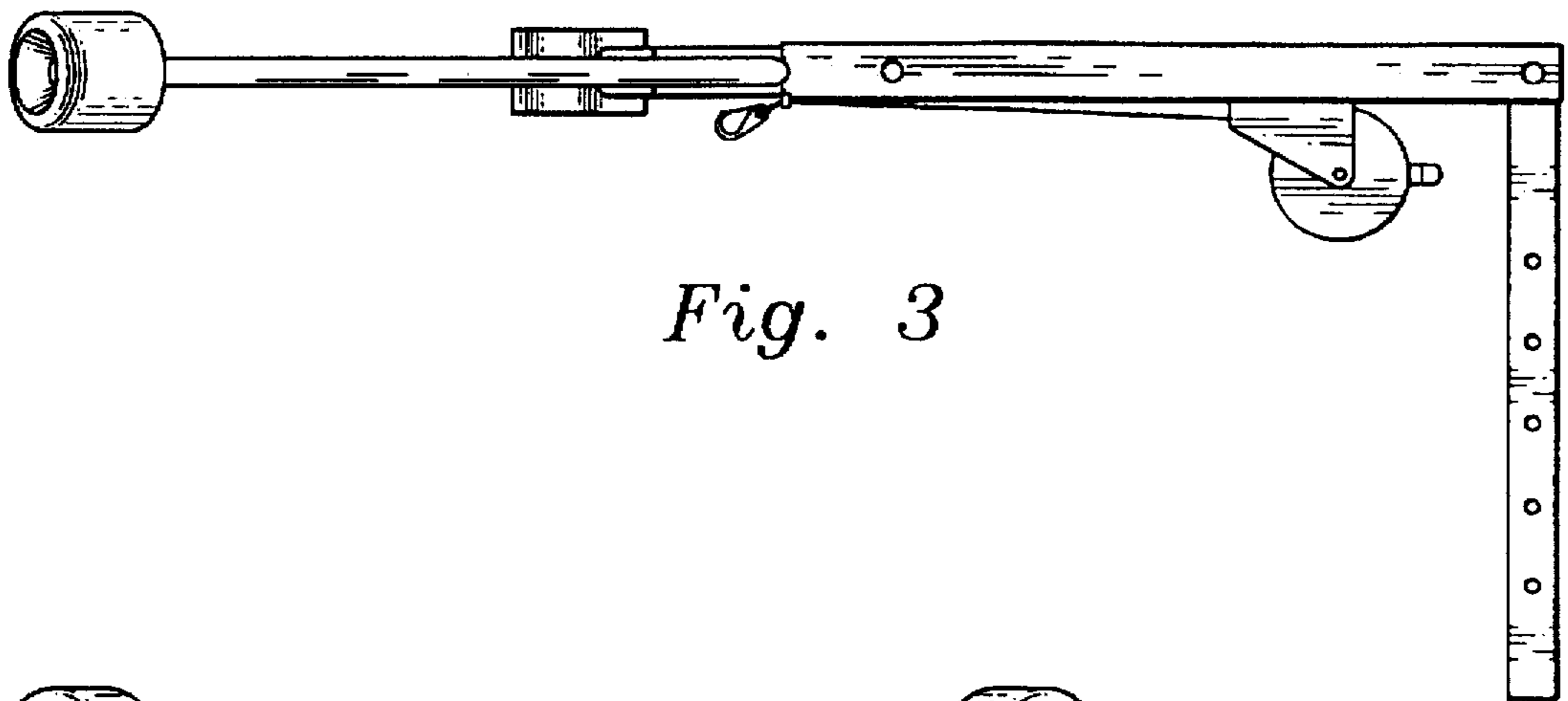




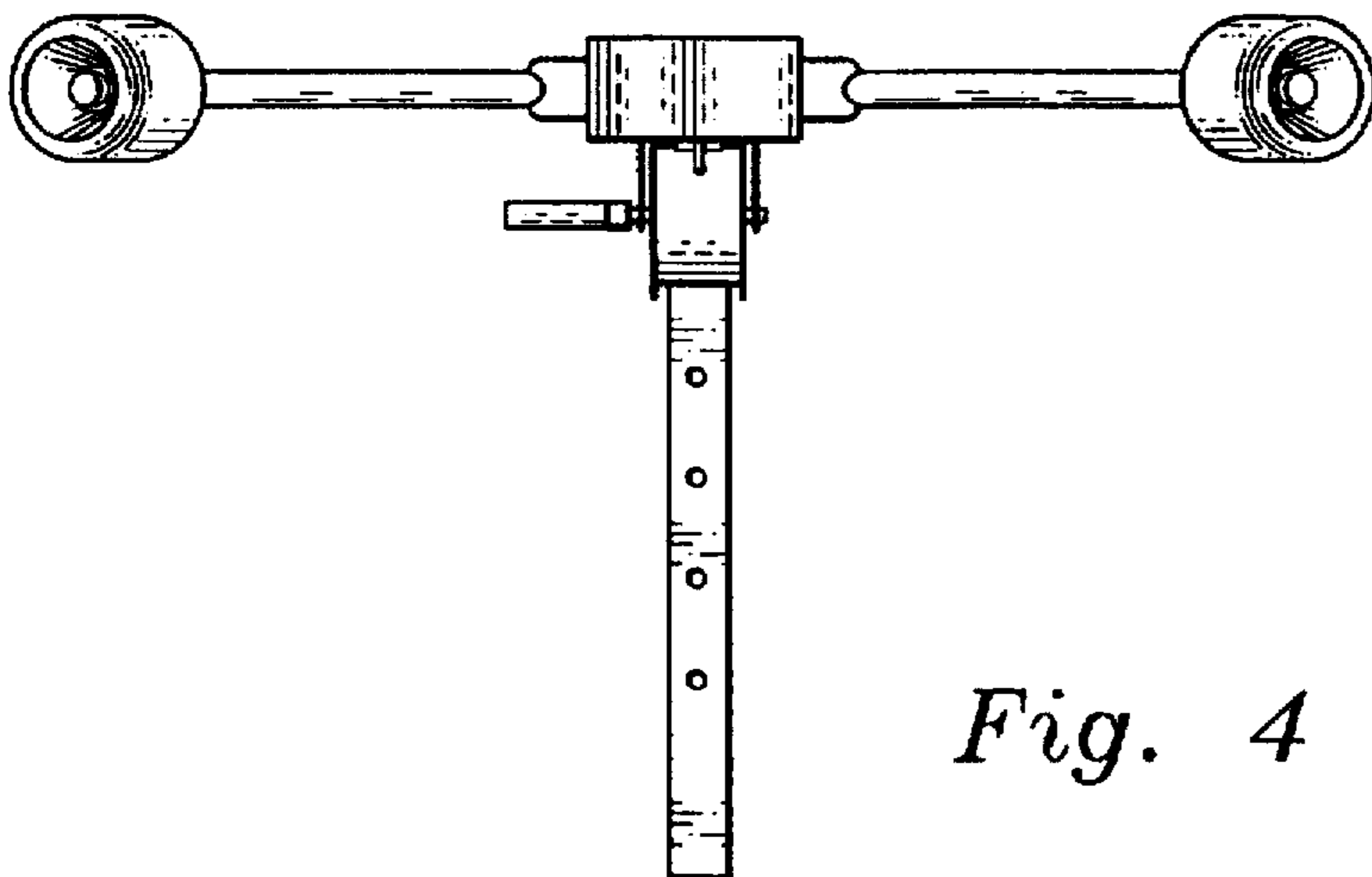
*Fig. 1*



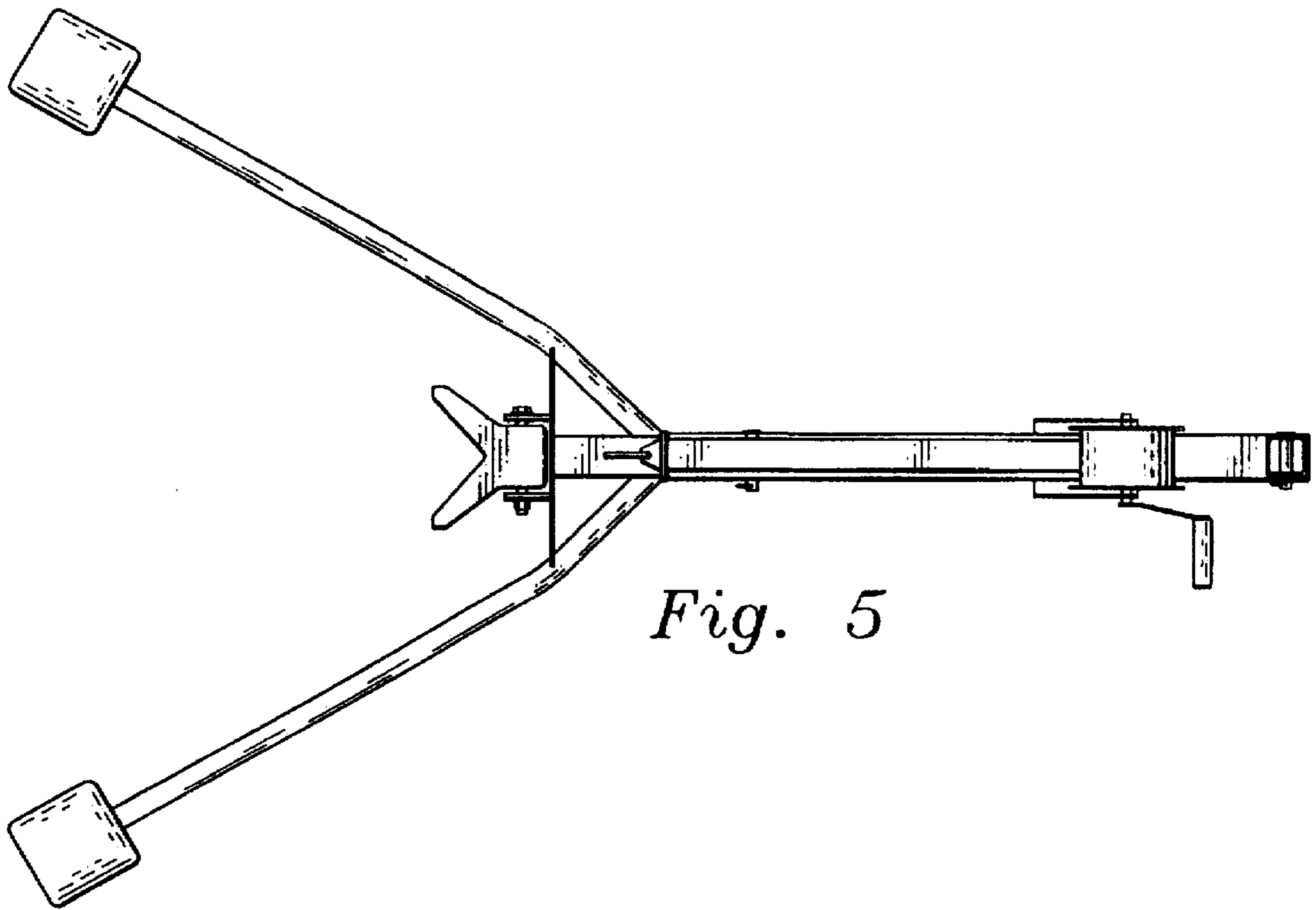
*Fig. 2*



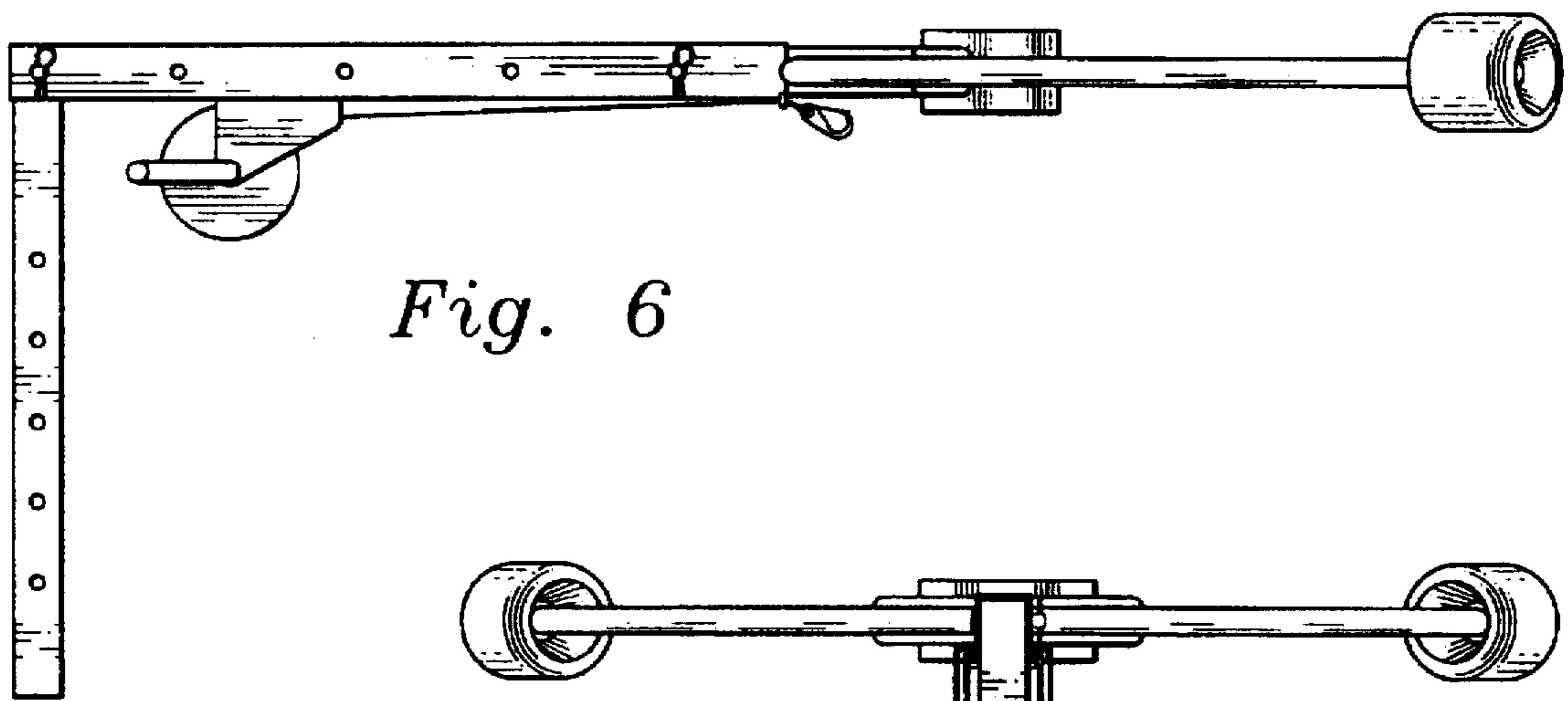
*Fig. 3*



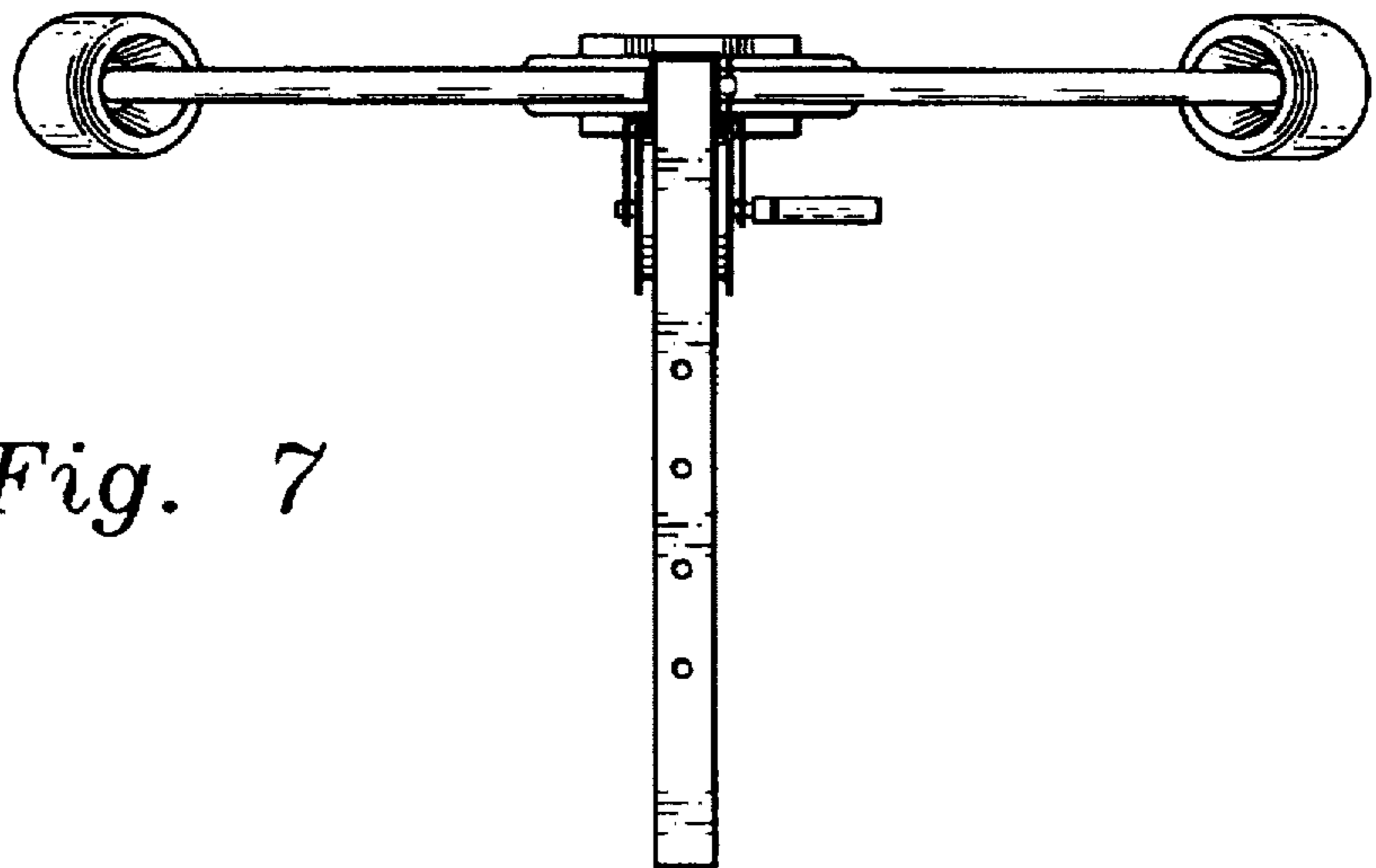
*Fig. 4*



*Fig. 5*



*Fig. 6*



*Fig. 7*

