



US00D384474S

United States Patent [19] White

[11] Patent Number: **Des. 384,474**

[45] Date of Patent: ****Sep. 30, 1997**

[54] VEHICLE MOUNTED JACK

[76] Inventor: **Anderson White**, 4731 Matthew Dr.,
Westland, Mich. 48185

[**] Term: **14 Years**

[21] Appl. No.: **52,736**

[22] Filed: **Apr. 2, 1996**

[51] LOC (6) Cl. **12-05**

[52] U.S. Cl. **D34/31**

[58] Field of Search D34/28, 31, 33;
254/1, 8 B, 120, 124, 126, DIG. 1

[56] References Cited

U.S. PATENT DOCUMENTS

D. 317,520	6/1991	Celette	D34/31
D. 349,386	8/1994	Piebenga	D34/31
4,360,187	11/1982	Chapman	254/124
4,653,727	3/1987	Chang et al.	254/126
4,979,723	12/1990	Wittersheim	D34/28
5,085,407	2/1992	Lonon	254/DIG. 1

Primary Examiner—A. Hugo Word

Assistant Examiner—Robin V. Taylor
Attorney, Agent, or Firm—Harold H. Dutton, Jr.; Diane F. Liebman

[57] CLAIM

The ornamental design for a vehicle mounted jack, as shown.

DESCRIPTION

FIG. 1 is a perspective view of a vehicle mounted jack showing my new design;
 FIG. 2 is a right side view thereof;
 FIG. 3 is a left side view thereof;
 FIG. 4 is a front view thereof;
 FIG. 5 is a rear view thereof;
 FIG. 6 is a top view thereof;
 FIG. 7 is a bottom view thereof;
 FIG. 8 is a top view of the control portion shown separately for ease of illustration;
 FIG. 9 is a bottom view thereof;
 FIG. 10 is a left side view thereof; and
 FIG. 11 is a right side view thereof.

1 Claim, 6 Drawing Sheets

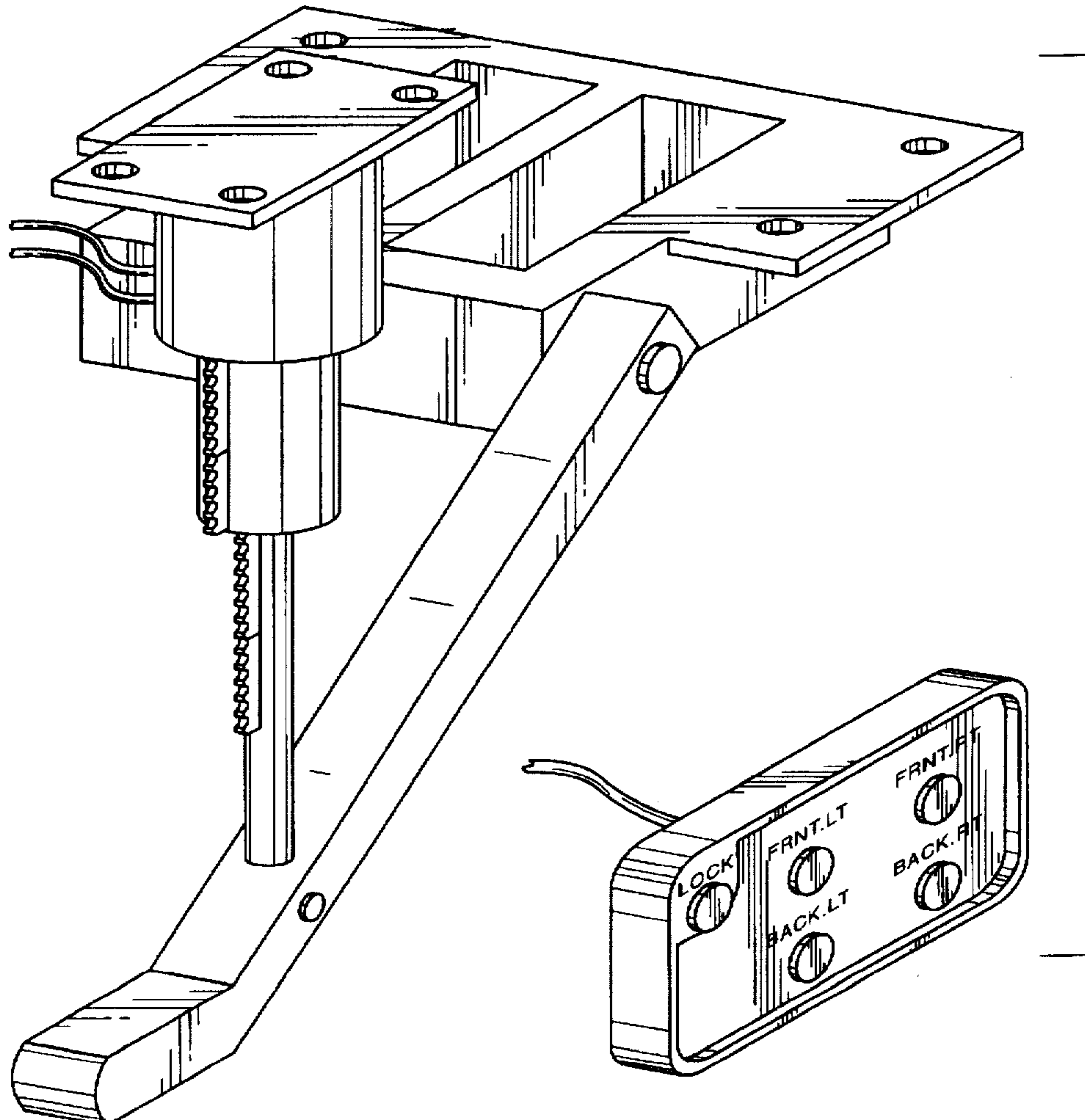

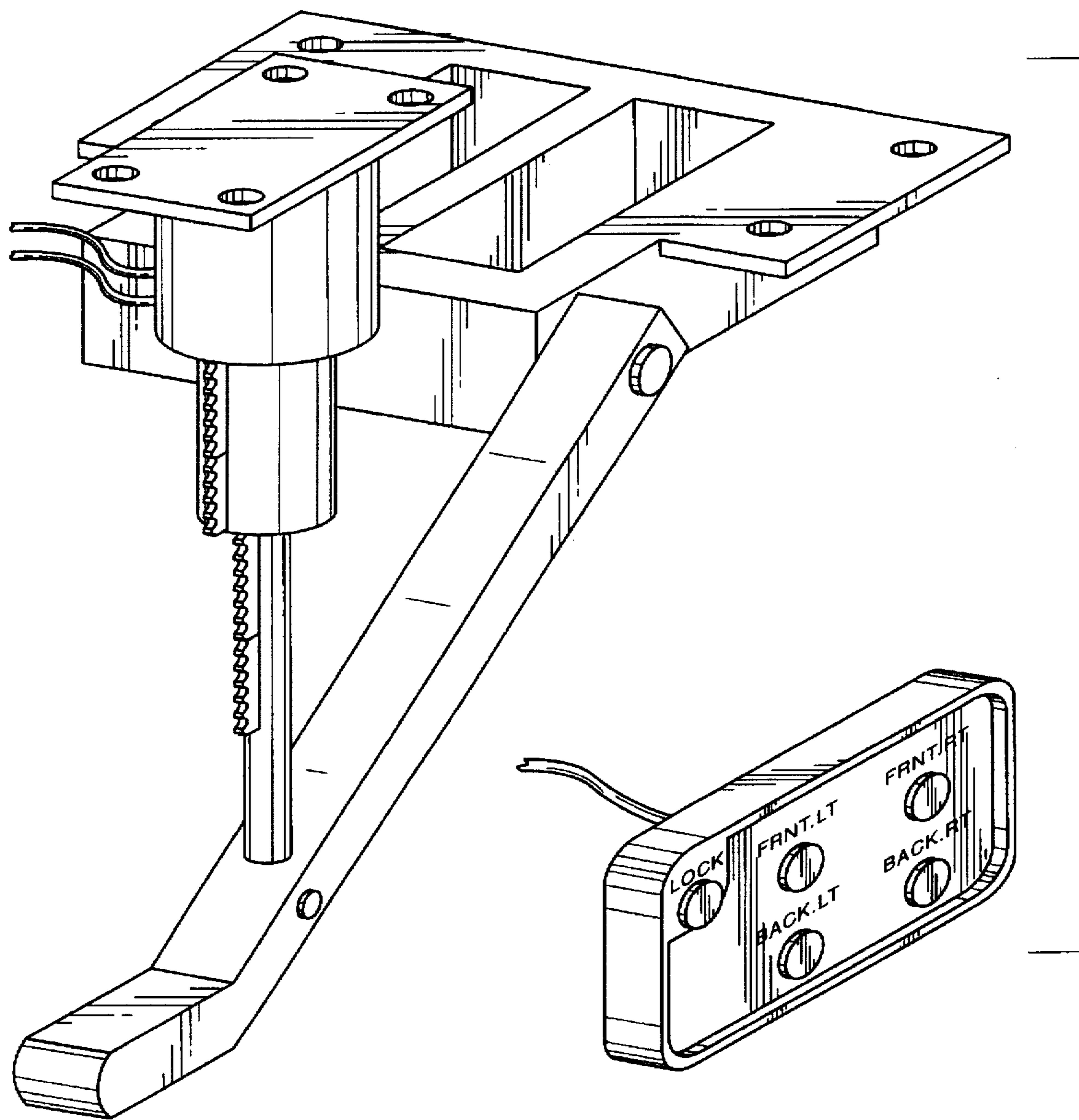

FIG. 1

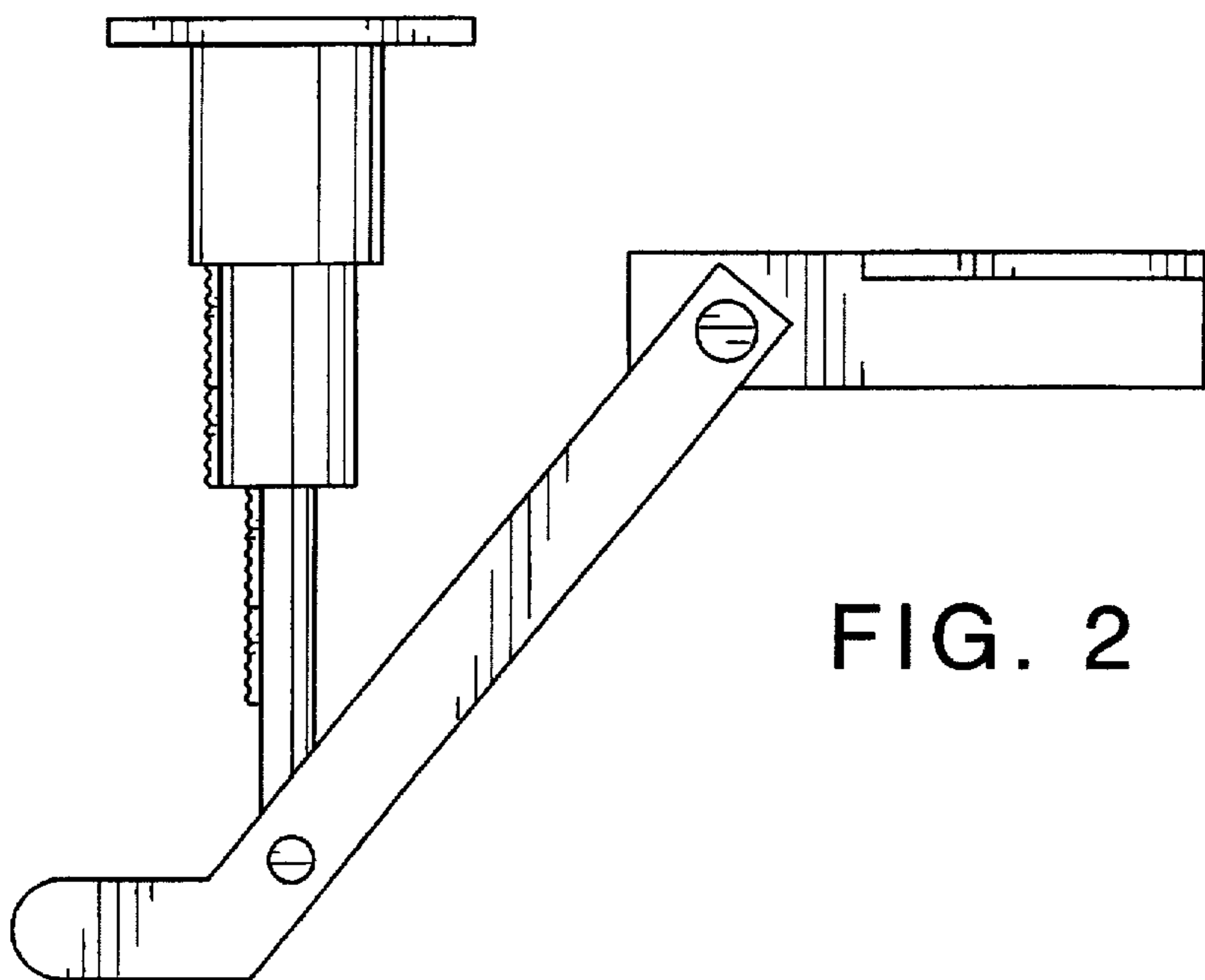

FIG. 2

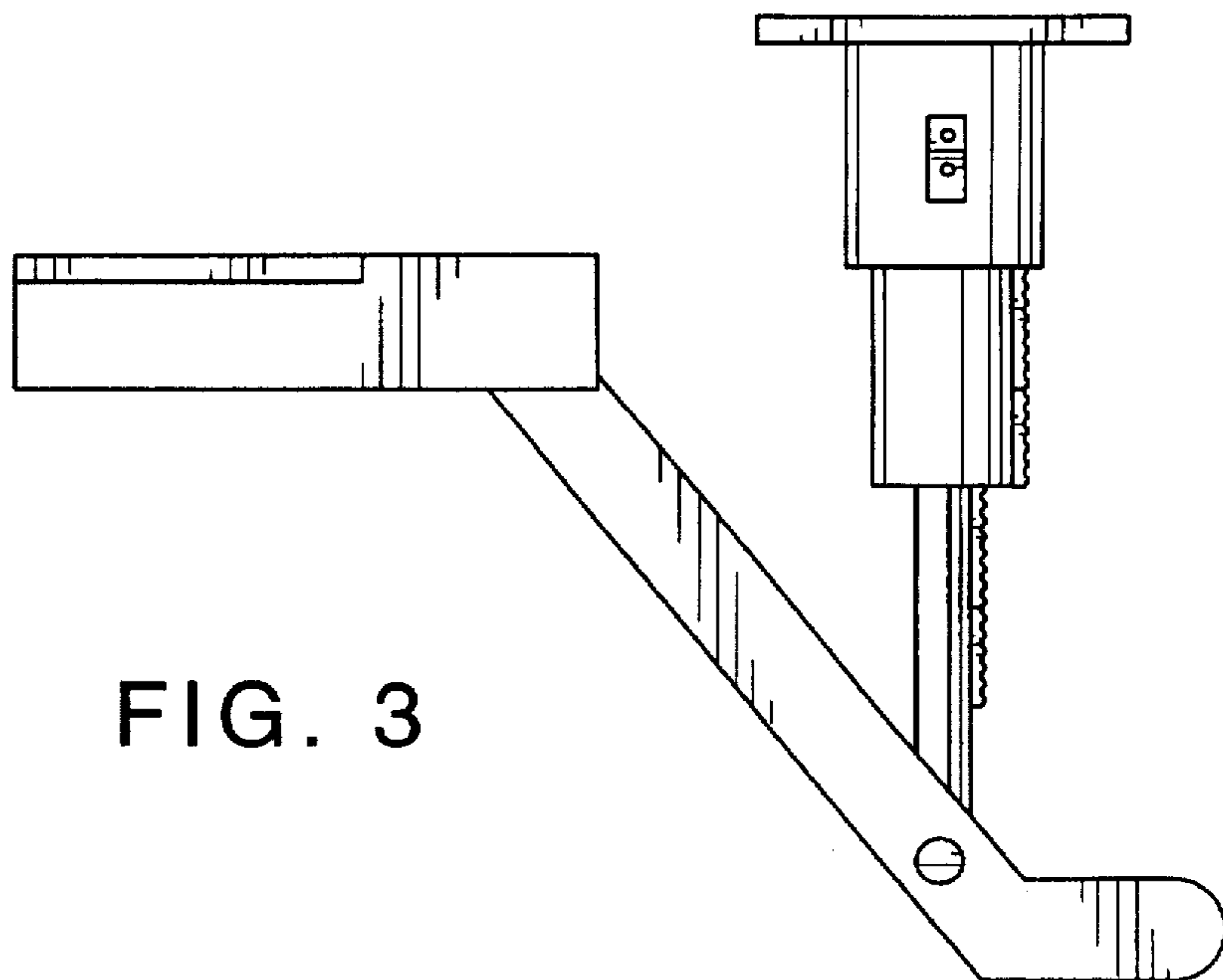

FIG. 3

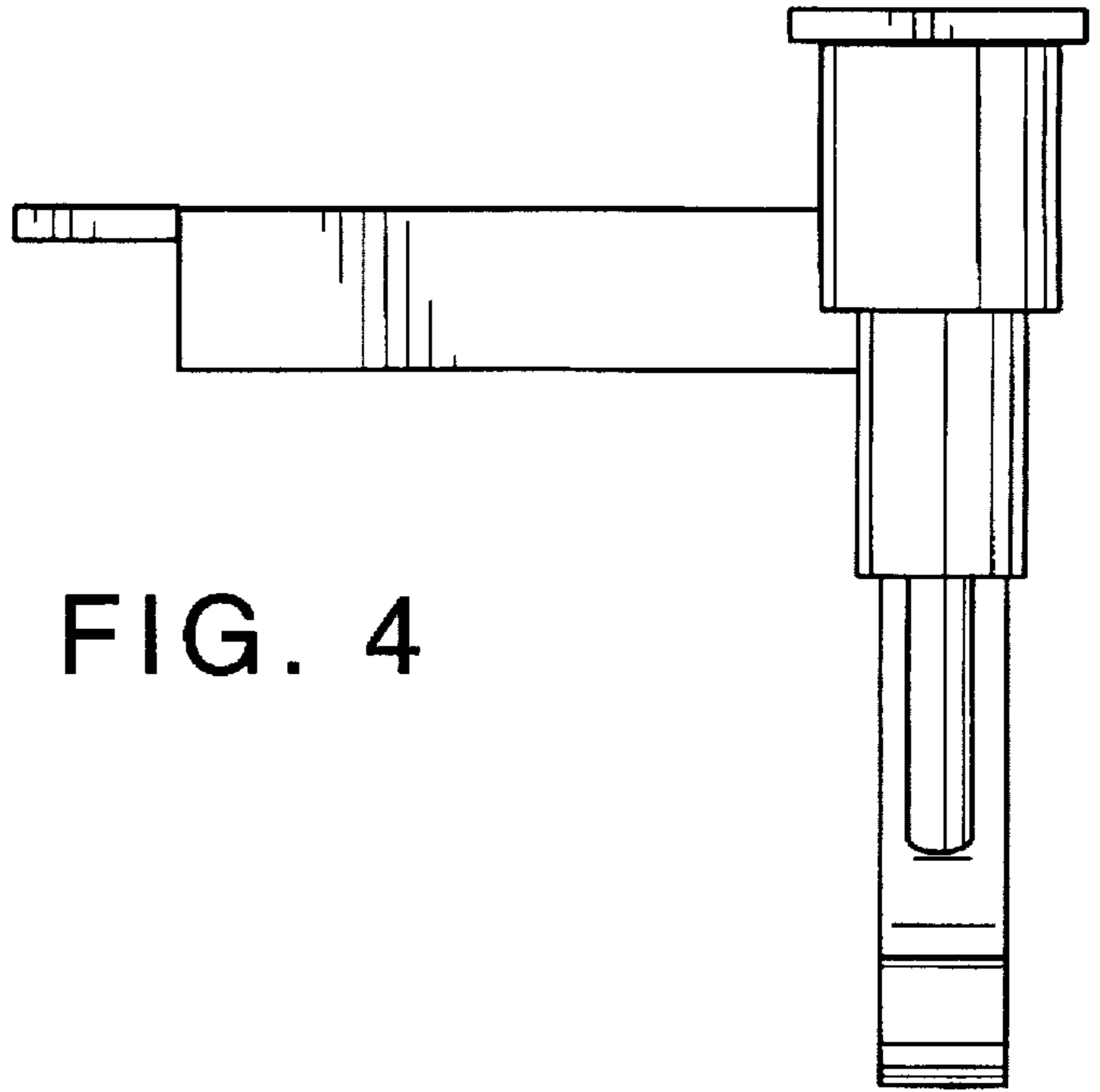

FIG. 4

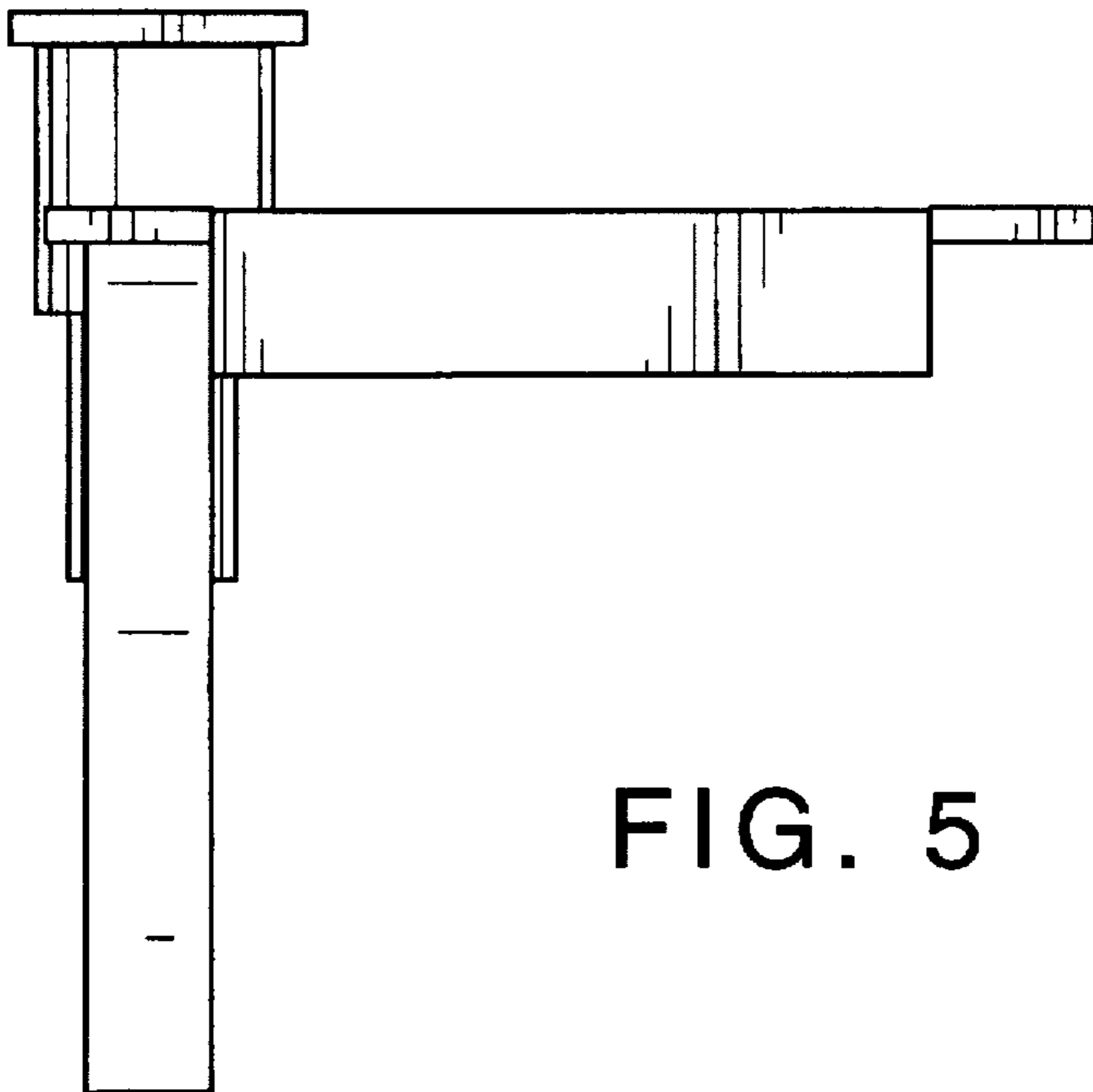

FIG. 5

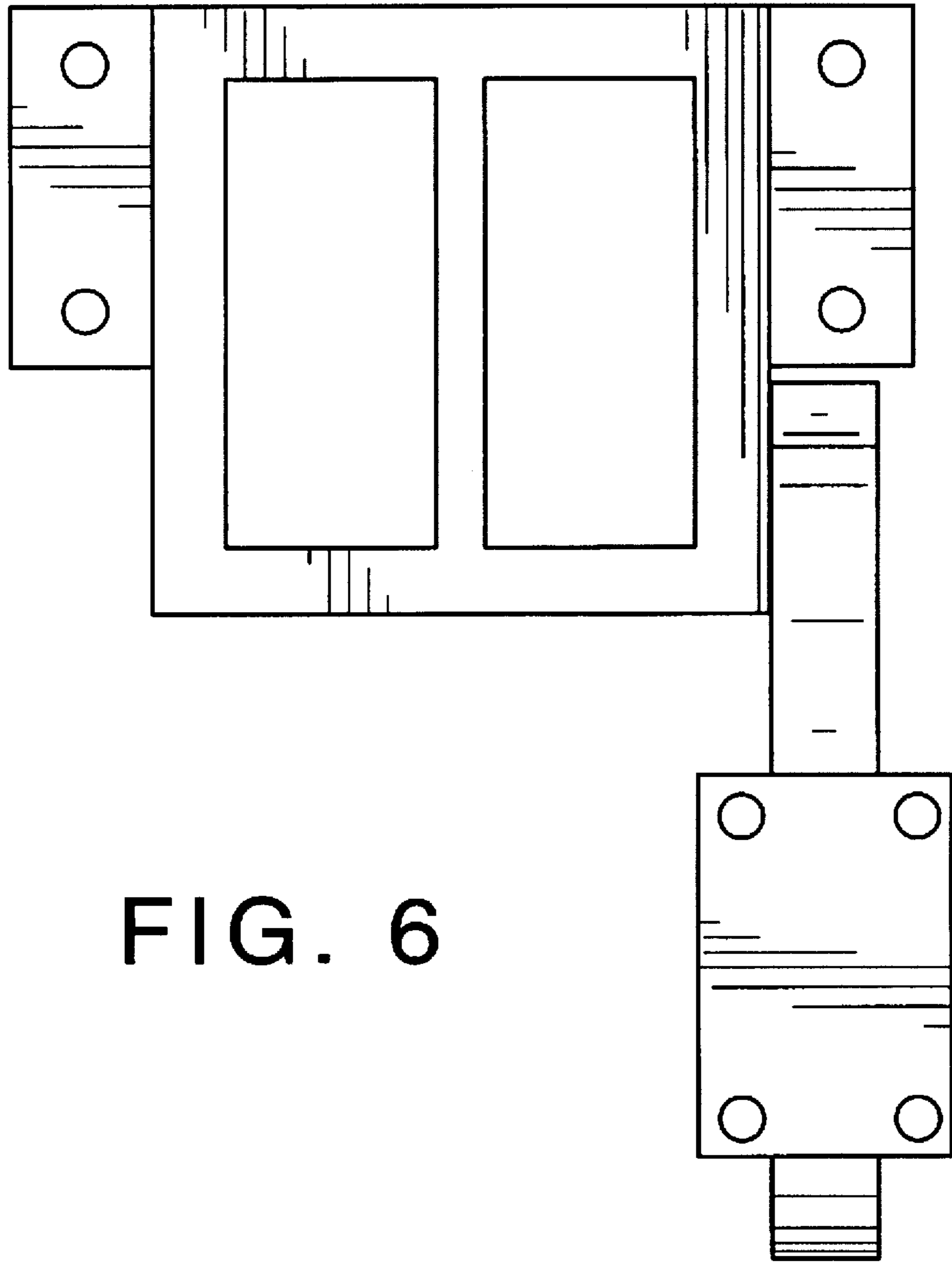
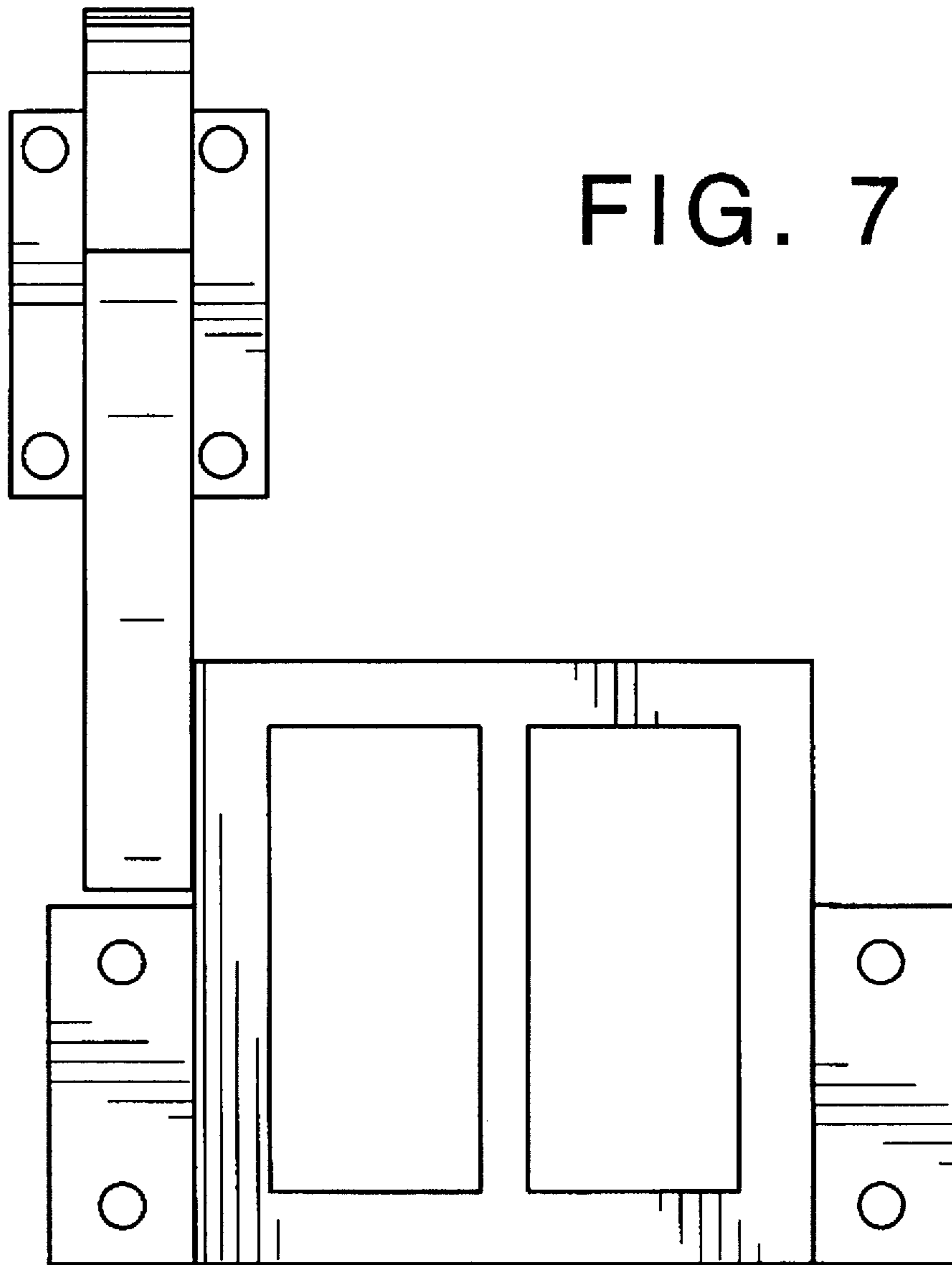

FIG. 6



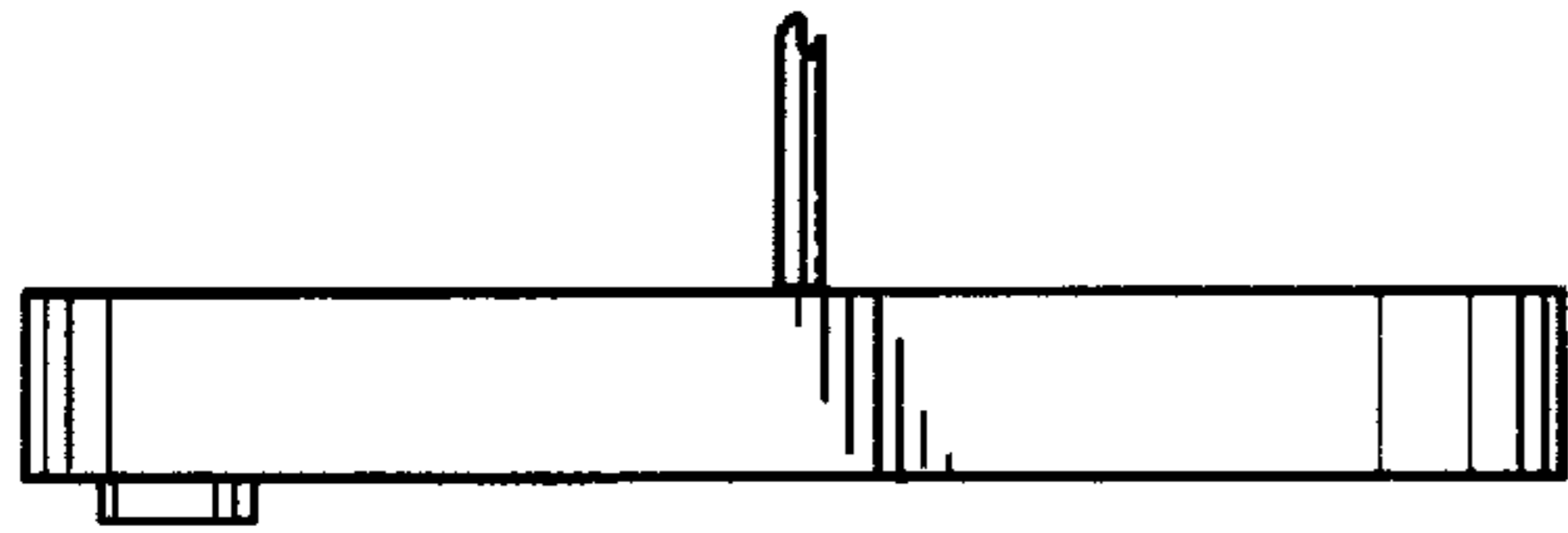

FIG. 8

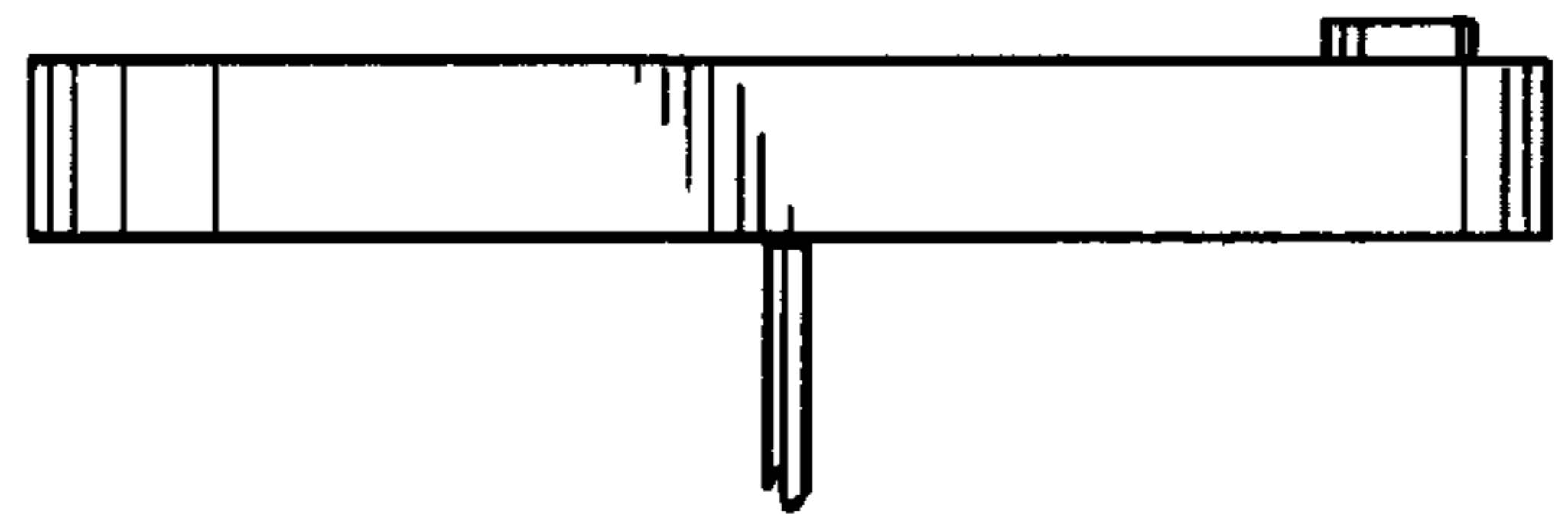

FIG. 9

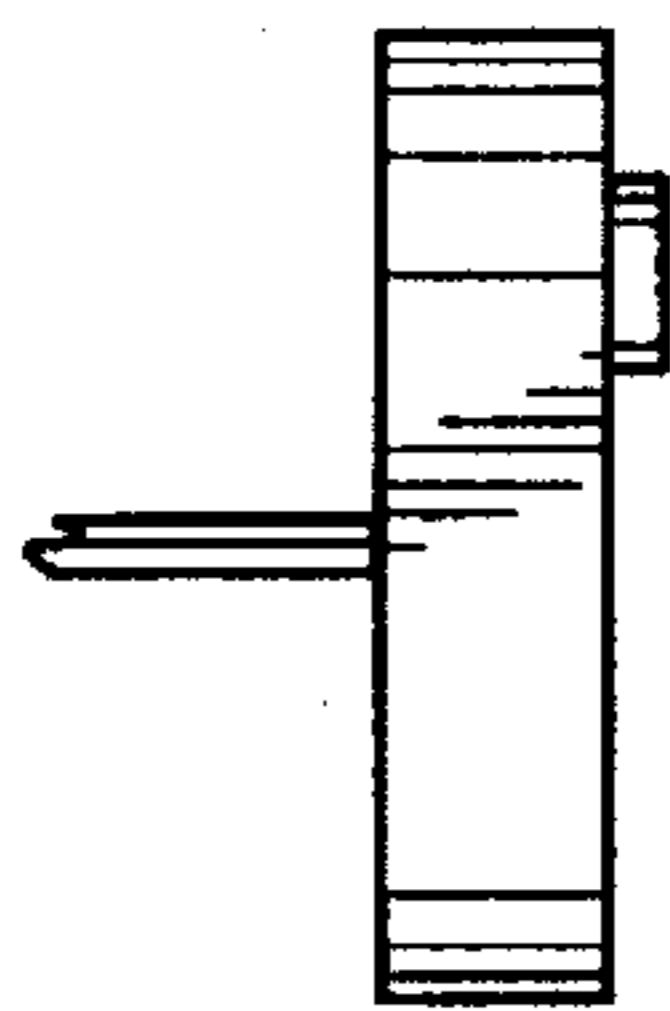

FIG. 10

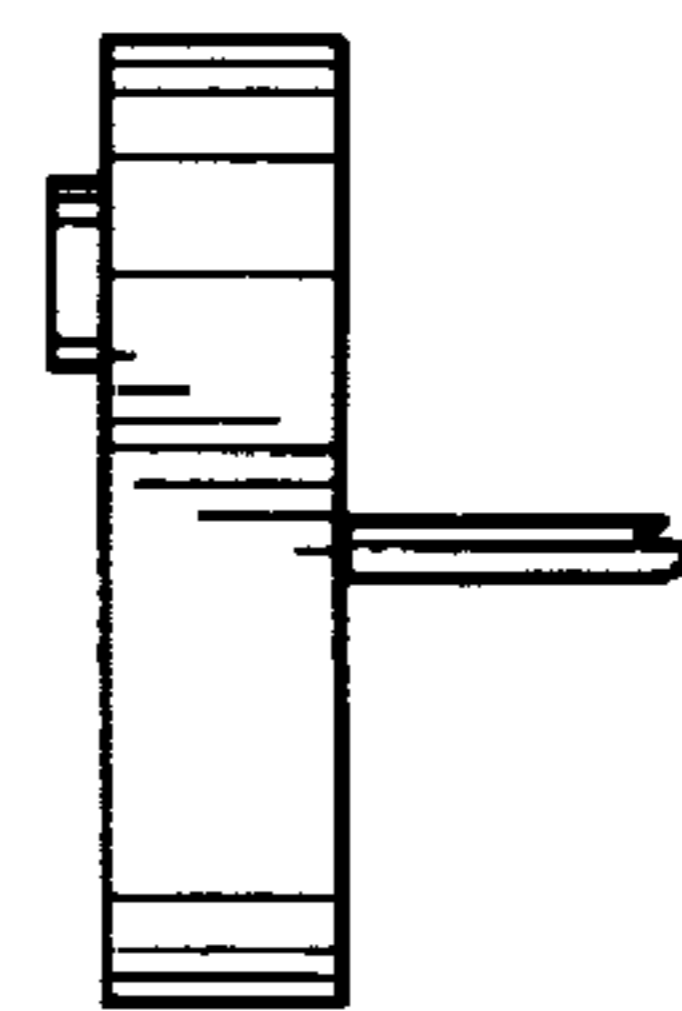

FIG. 11