

US00D384402S

United States Patent [19]

[11] Patent Number: **Des. 384,402**

Doughty et al.

[45] Date of Patent: ****Sep. 30, 1997**

[54] **FAUCET**

[75] Inventors: **Frederic C. Doughty**, S. Pasadena;
Darren M. Mark, Castaic, both of
Calif.

[73] Assignee: **Emhart Inc.**, Newark, Del.

[**] Term: **14 Years**

[21] Appl. No.: **44,653**

[22] Filed: **Sep. 28, 1995**

[51] LOC (6) Cl. **23-01**

[52] U.S. Cl. **D23/241**

[58] Field of Search **D23/238-243,**
D23/250-257; 4/675-678; 137/801

[56] **References Cited**

U.S. PATENT DOCUMENTS

- D. 182,867 5/1958 Young .
- D. 207,044 2/1967 Hurwitz .
- D. 221,429 8/1971 Petterson .
- D. 235,546 6/1975 Landell .
- D. 258,519 3/1981 Thevenot D23/243
- D. 260,677 9/1981 Thevenot .
- D. 279,923 7/1985 Niemann et al. D23/255
- D. 285,106 8/1986 Yost .
- D. 288,835 3/1987 Yost .
- D. 288,836 3/1987 Yost .

- D. 288,837 3/1987 Yost D23/243
- D. 289,318 4/1987 Yost .
- D. 290,388 6/1987 Yost .
- D. 296,461 6/1988 Yost D23/241
- D. 340,506 10/1993 Sauter et al. .
- D. 359,342 6/1995 Doughty .

OTHER PUBLICATIONS

1991, Consumer Products Catalog, Price Pfister, p. 5.

Primary Examiner—Louis S. Zarfes

Assistant Examiner—Eric Watterson

Attorney, Agent, or Firm—J. Bruce Hoofnagle

[57] **CLAIM**

The ornamental design for faucet, as shown and described.

DESCRIPTION

FIG. 1 is a perspective view of our new design of a faucet;
 FIG. 2 is a front elevational view of our new design of the faucet;
 FIG. 3 is a rear elevational view of our new design of the faucet;
 FIG. 4 is a right side elevational view of our new design of the faucet, a left side elevational view thereof being a mirror image of the right side elevational thereof;
 FIG. 5 is a top plan view of our new design of the faucet; and,
 FIG. 6 is a bottom plan view of our new design of the faucet.

1 Claim, 6 Drawing Sheets

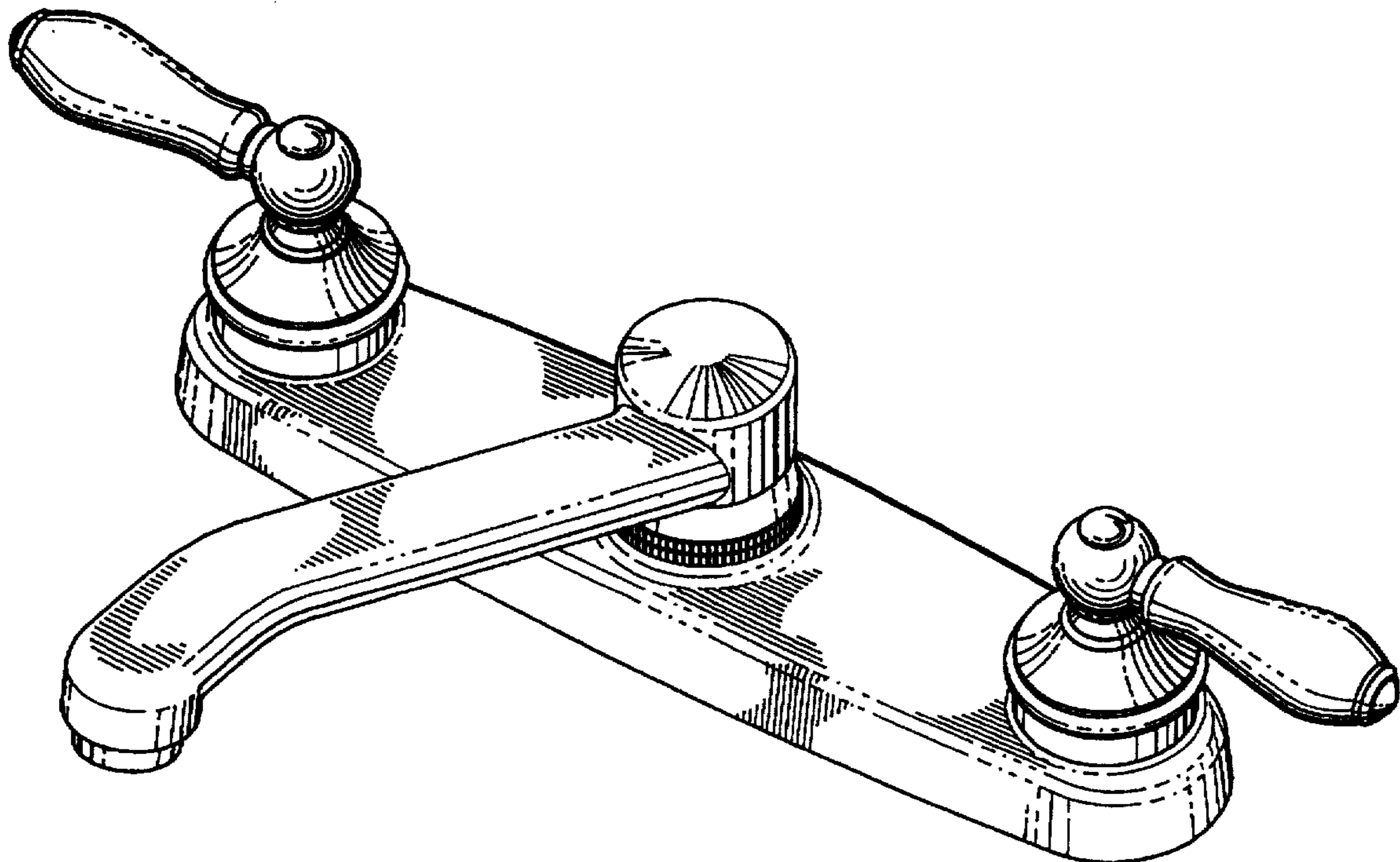

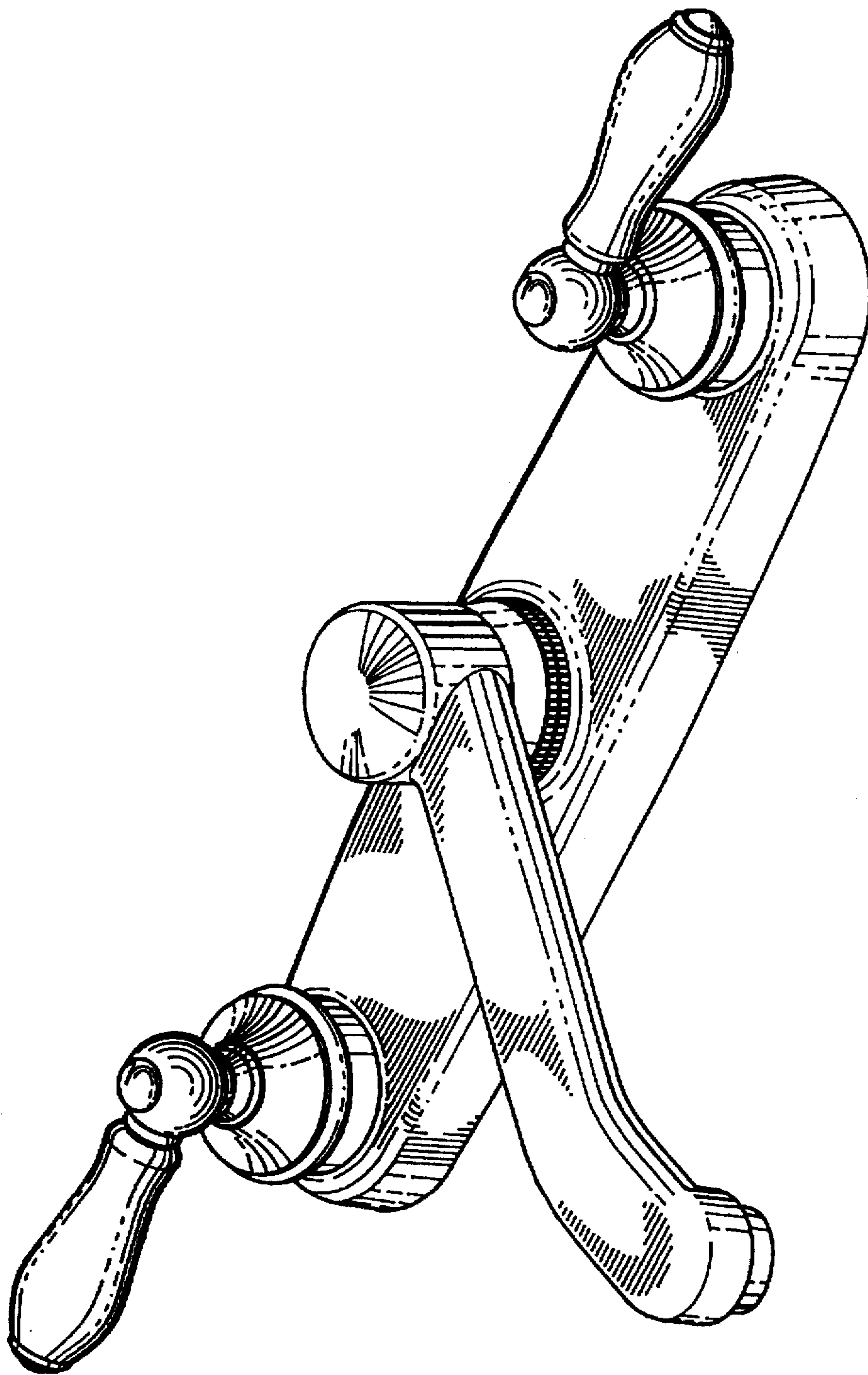

FIG. 1

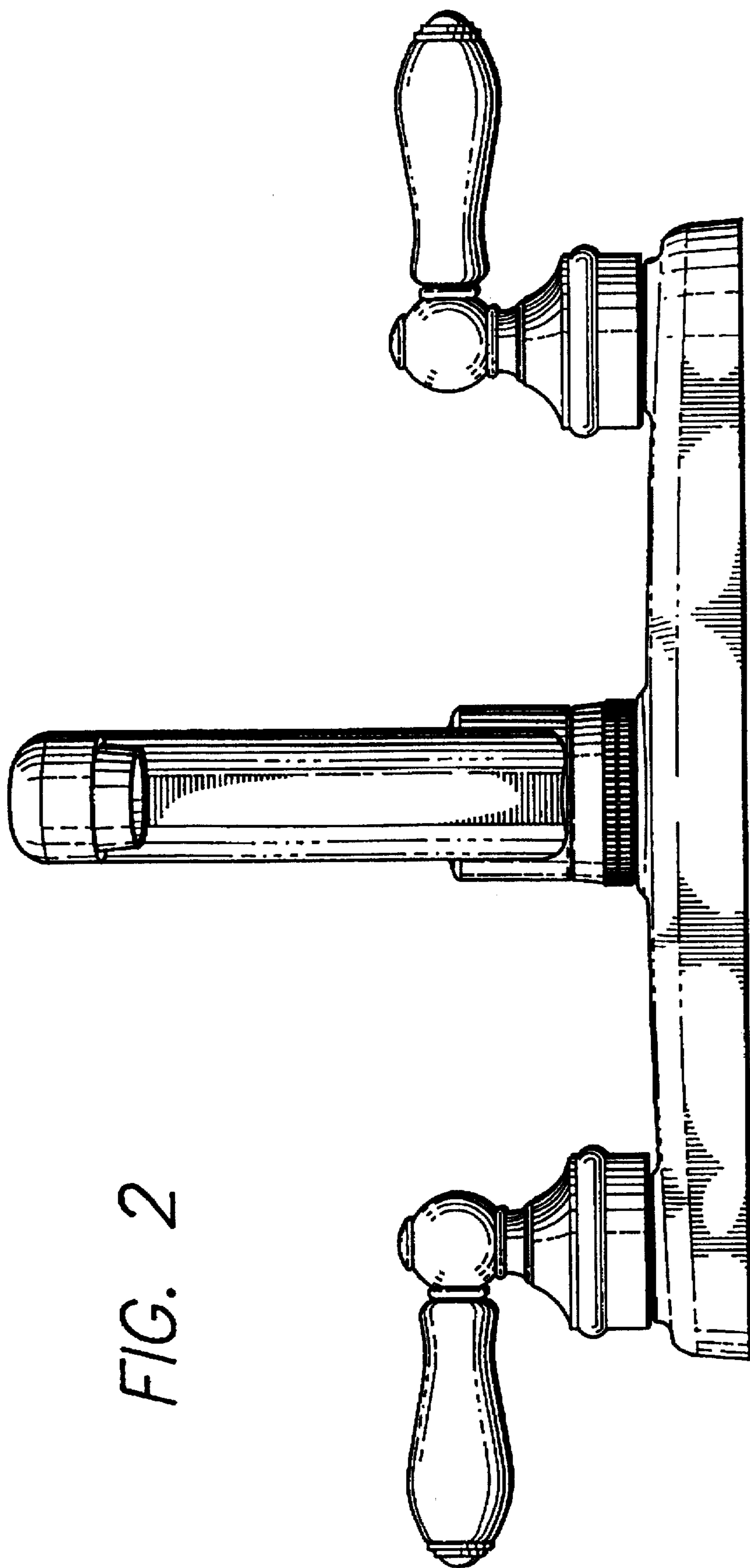

FIG. 2

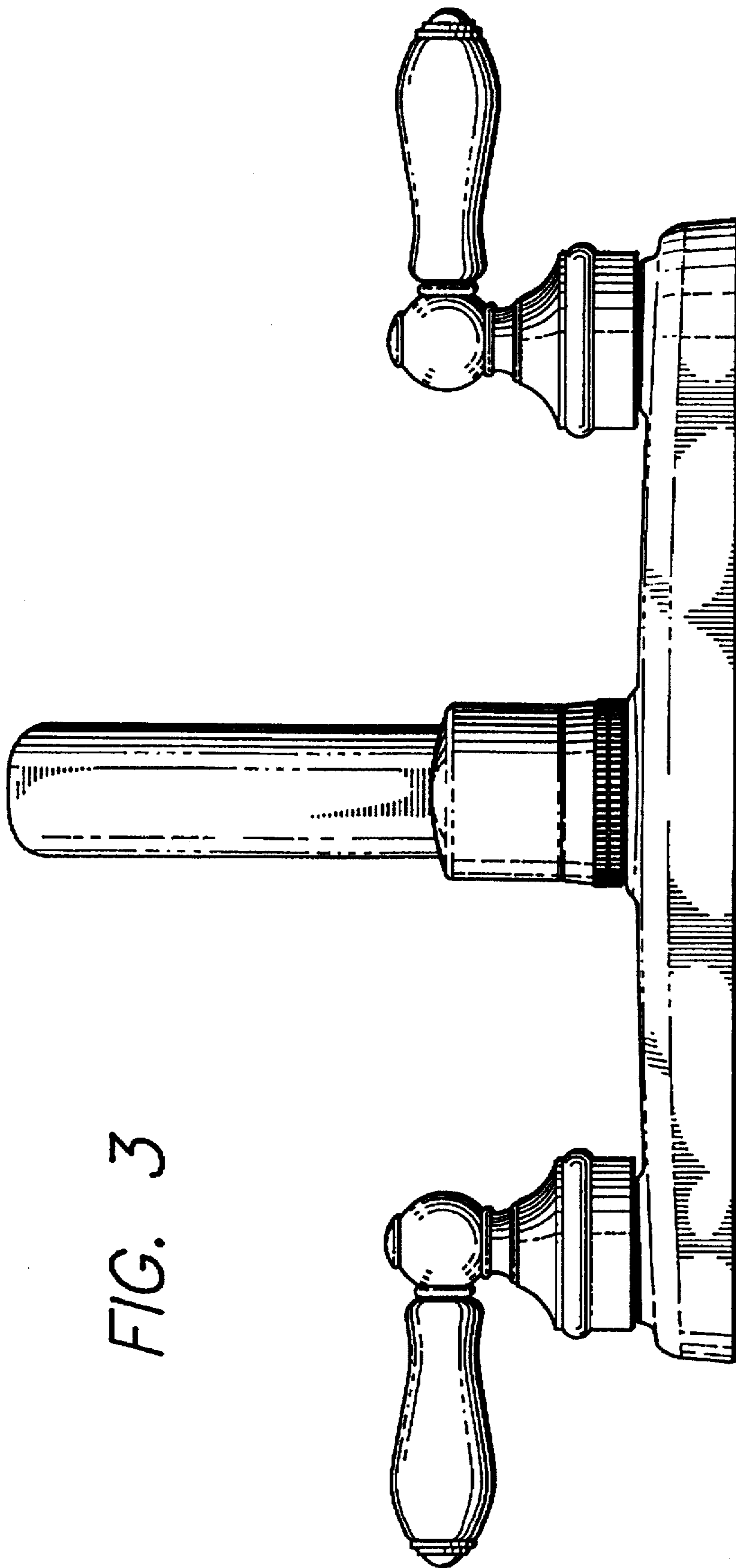

FIG. 3

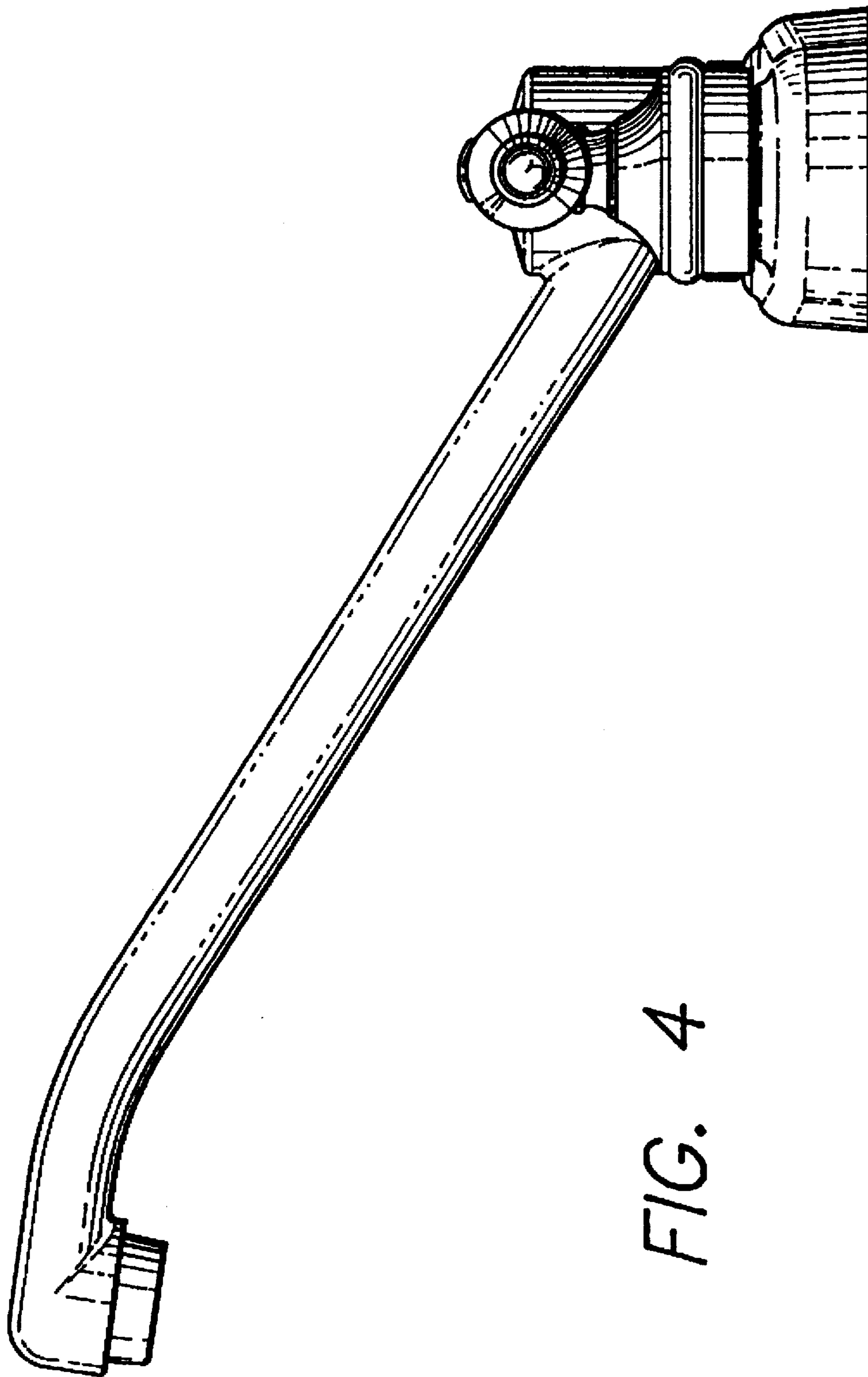

FIG. 4

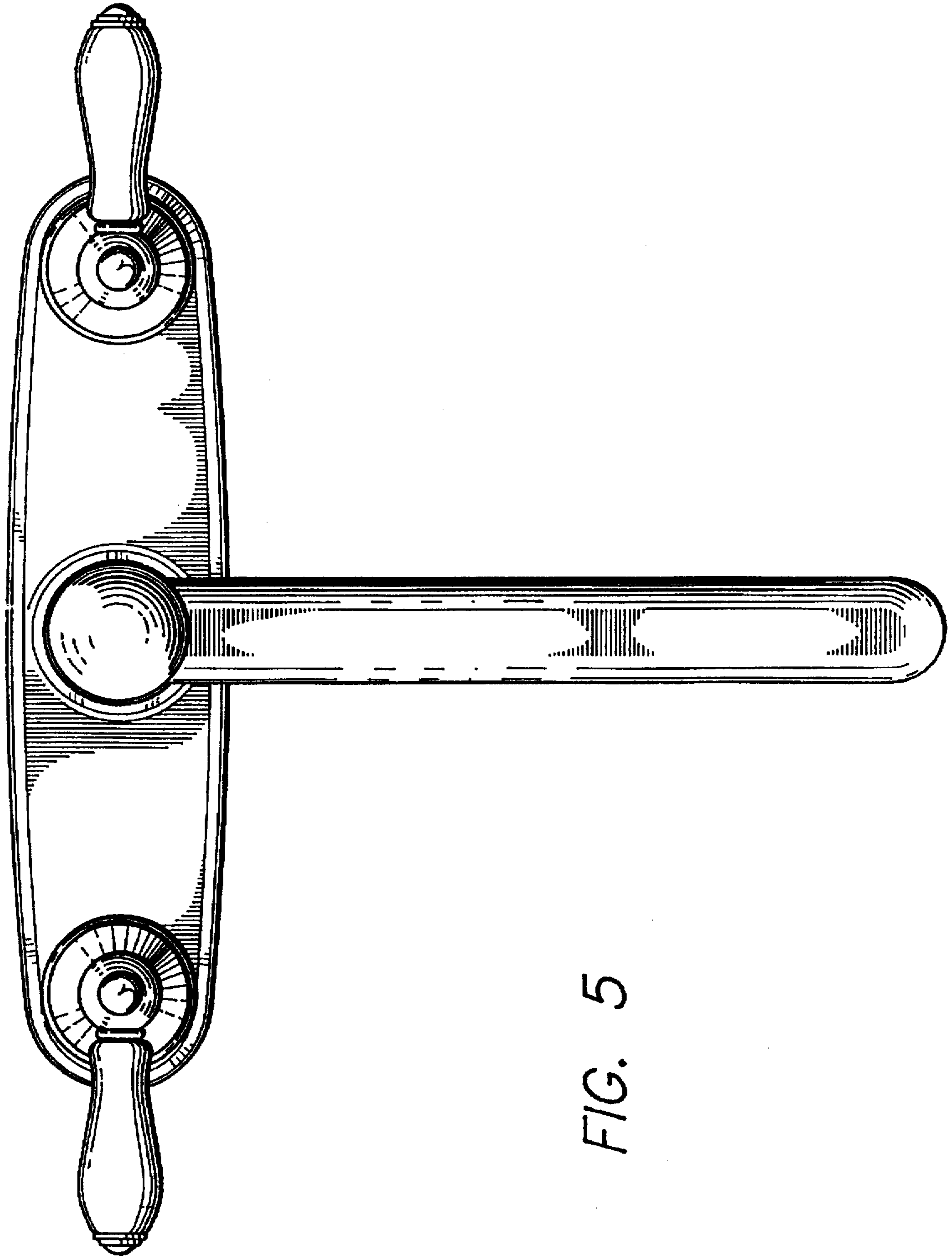

FIG. 5

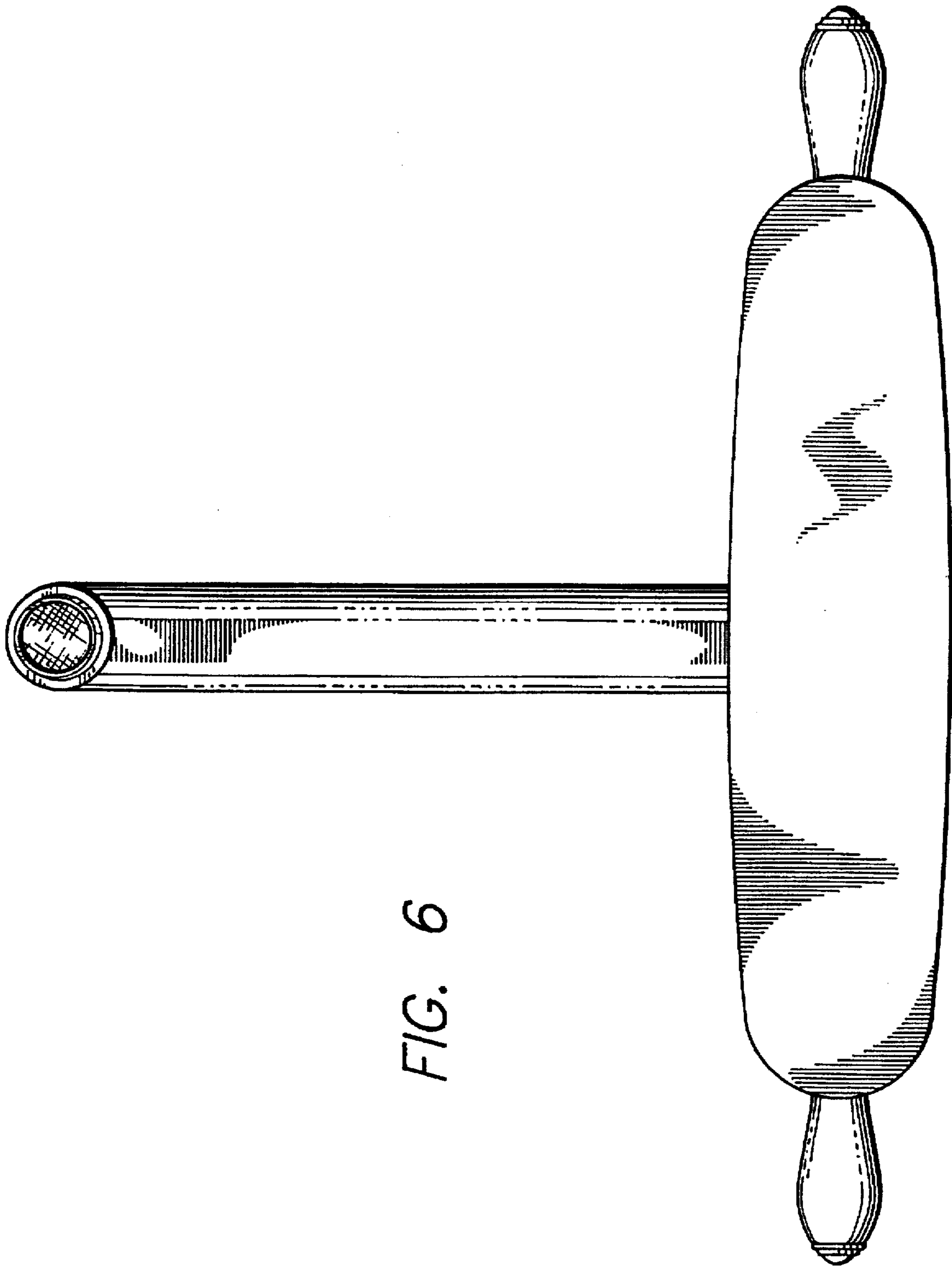

FIG. 6