



US00D384326S

United States Patent [19]

[11] Patent Number: Des. 384,326

Fetz et al.

[45] Date of Patent: **Sep. 30, 1997

[54] **TRAILER SIDE BOTTOM RAIL**

[75] Inventors: **Charles R. Fetz**, Savannah, Ga.; **James T. Colling**, Memphis, Tenn.

[73] Assignee: **Great Dane Trailers, Inc.**, Savannah, Ga.

[**] Term: **14 Years**

[21] Appl. No.: **41,065**

[22] Filed: **Jul. 5, 1995**

[51] LOC (6) Cl. **12-16**

[52] U.S. Cl. **D12/414**

[58] Field of Search D13/414; D8/300; D12/169, 167, 190; D25/119-125; 293/102, 128; 428/31; 296/180-183, 36

[56] **References Cited**

U.S. PATENT DOCUMENTS

D. 253,130	10/1979	Broadbent	D25/119
D. 299,273	1/1989	Pittman, Jr.	D25/119
D. 304,085	10/1989	Hockney	D25/119
D. 328,272	7/1992	Hasmans	D12/169
D. 343,005	1/1994	Moss et al.	D25/119
D. 360,038	7/1995	Bancroft	D25/119

Primary Examiner—Melody N. Brown
Attorney, Agent, or Firm—Dority & Manning

[57] **CLAIM**

The ornamental design for a trailer side bottom rail, as shown and described.

DESCRIPTION

FIG. 1 is a front and side perspective view of a trailer side bottom rail showing our new design, the broken lines are shown for illustrative purposes only and form no part of the claimed design;

FIG. 2 is an enlarged fragmentary front and side perspective view thereof;

FIG. 3 is a greatly enlarged fragmentary end elevational view thereof;

FIG. 4 is a greatly enlarged fragmentary top plan view thereof;

FIG. 5 is a greatly enlarged fragmentary front elevational view thereof;

FIG. 6 is a greatly enlarged fragmentary rear elevational view thereof; and,

FIG. 7 is a greatly enlarged fragmentary bottom view thereof.

The end portions of the design shown broken away in FIGS. 2, 4, 5, 6 and 7 are for convenience of illustration.

1 Claim, 3 Drawing Sheets

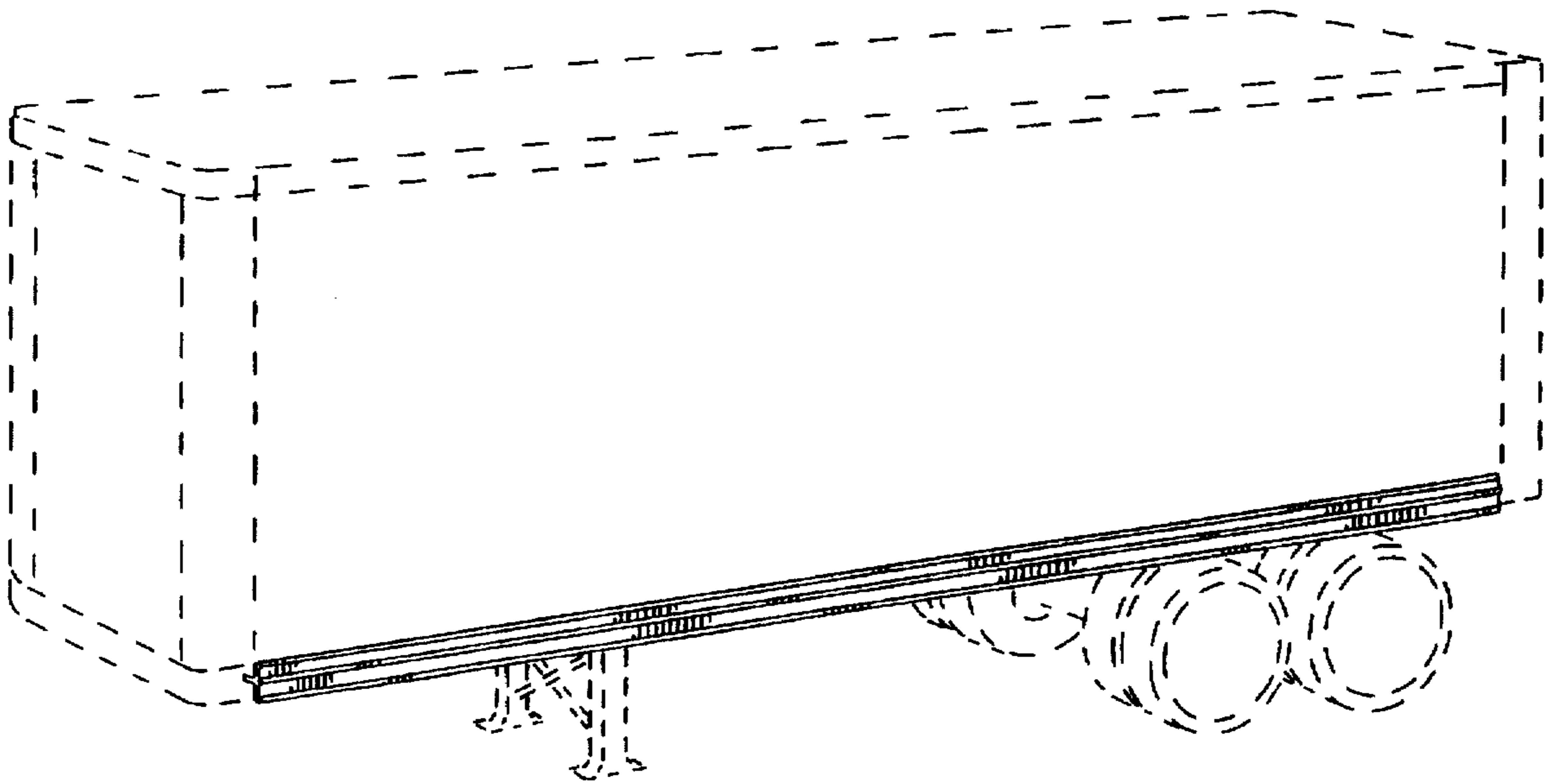

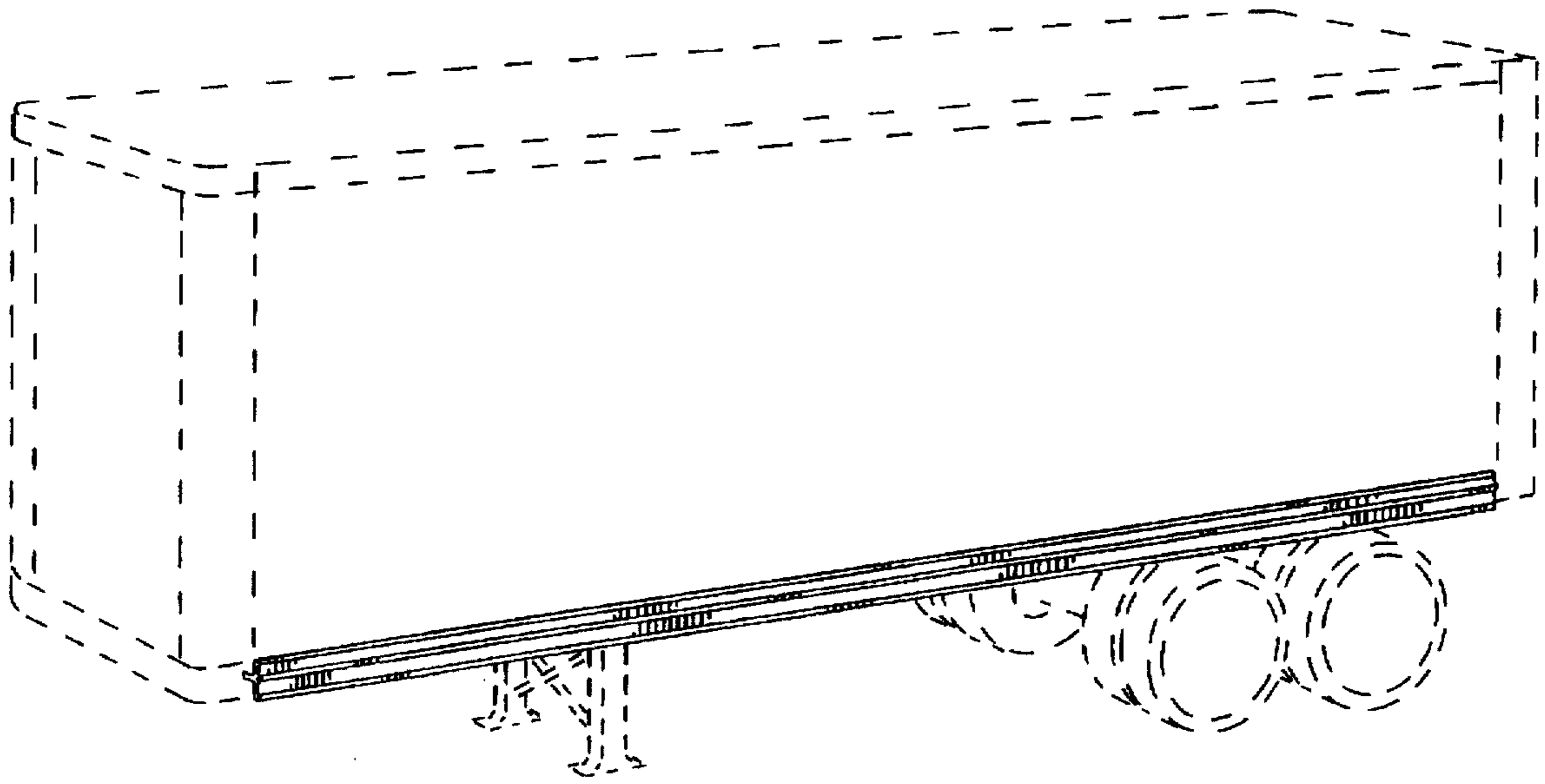

FIG. 1

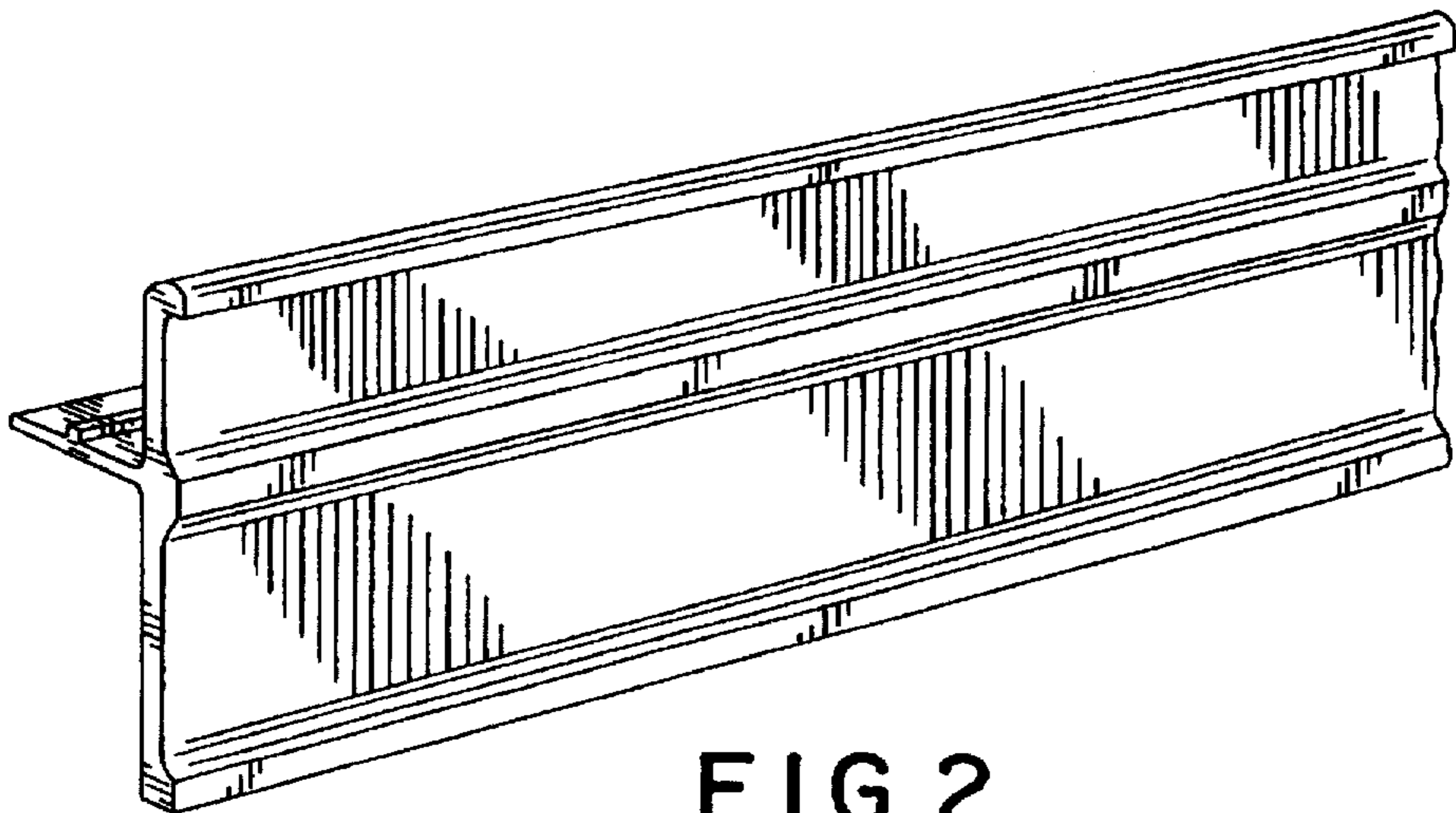

FIG. 2

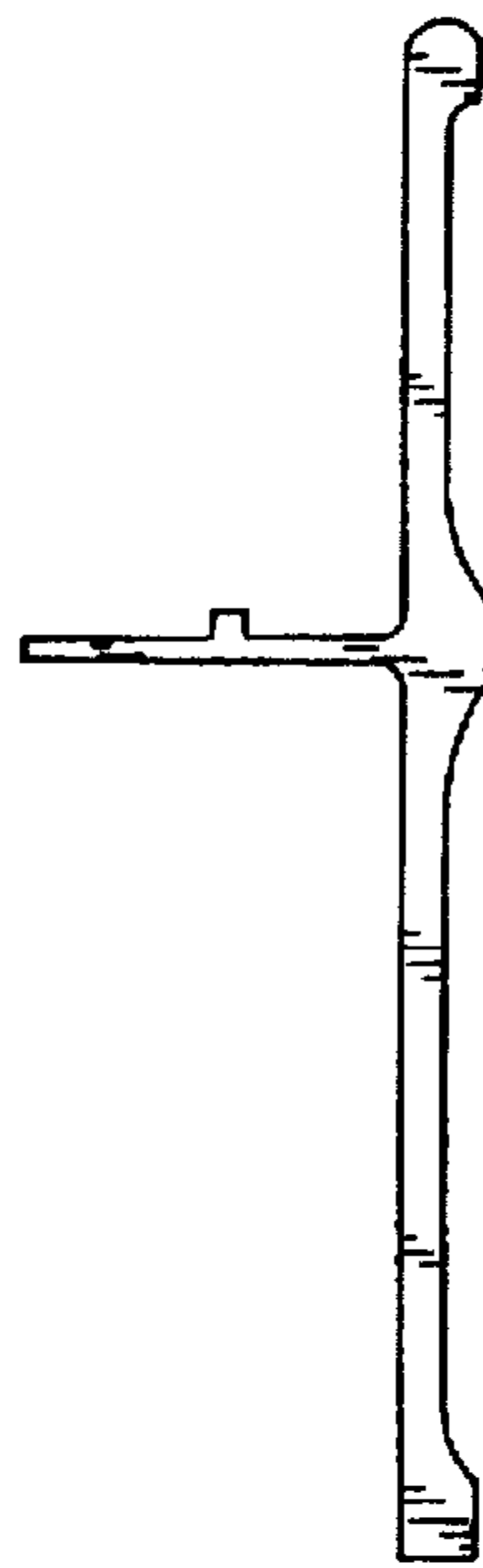

FIG. 3

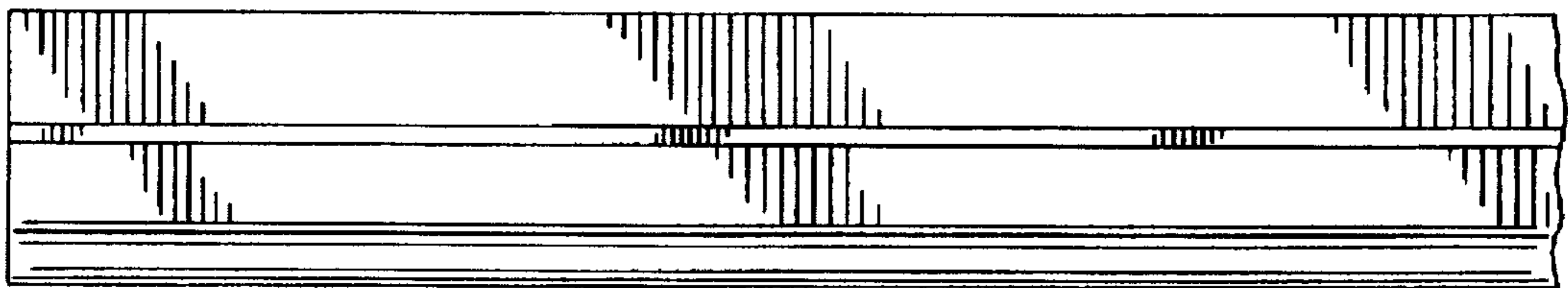

FIG. 4

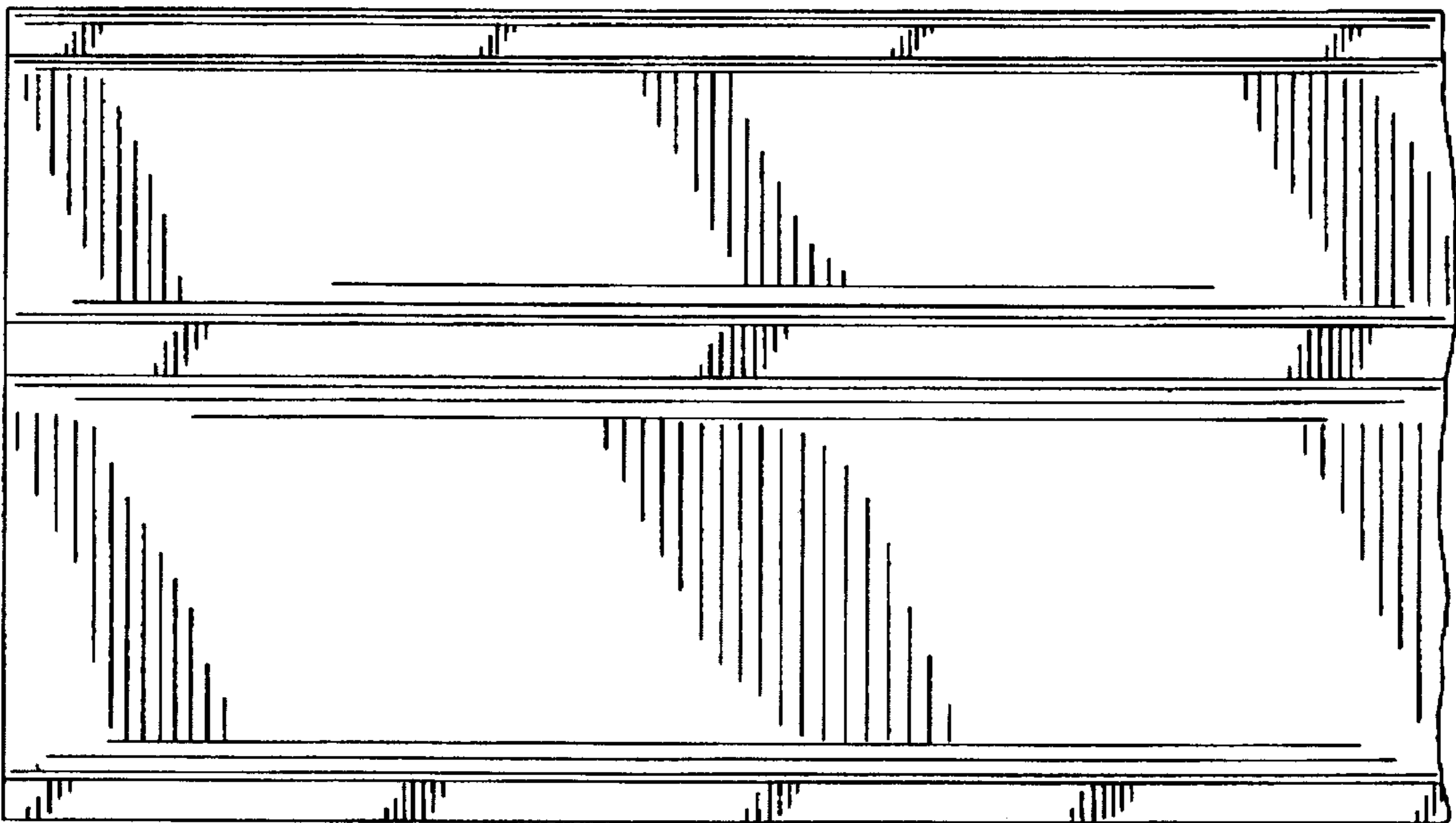

FIG. 5

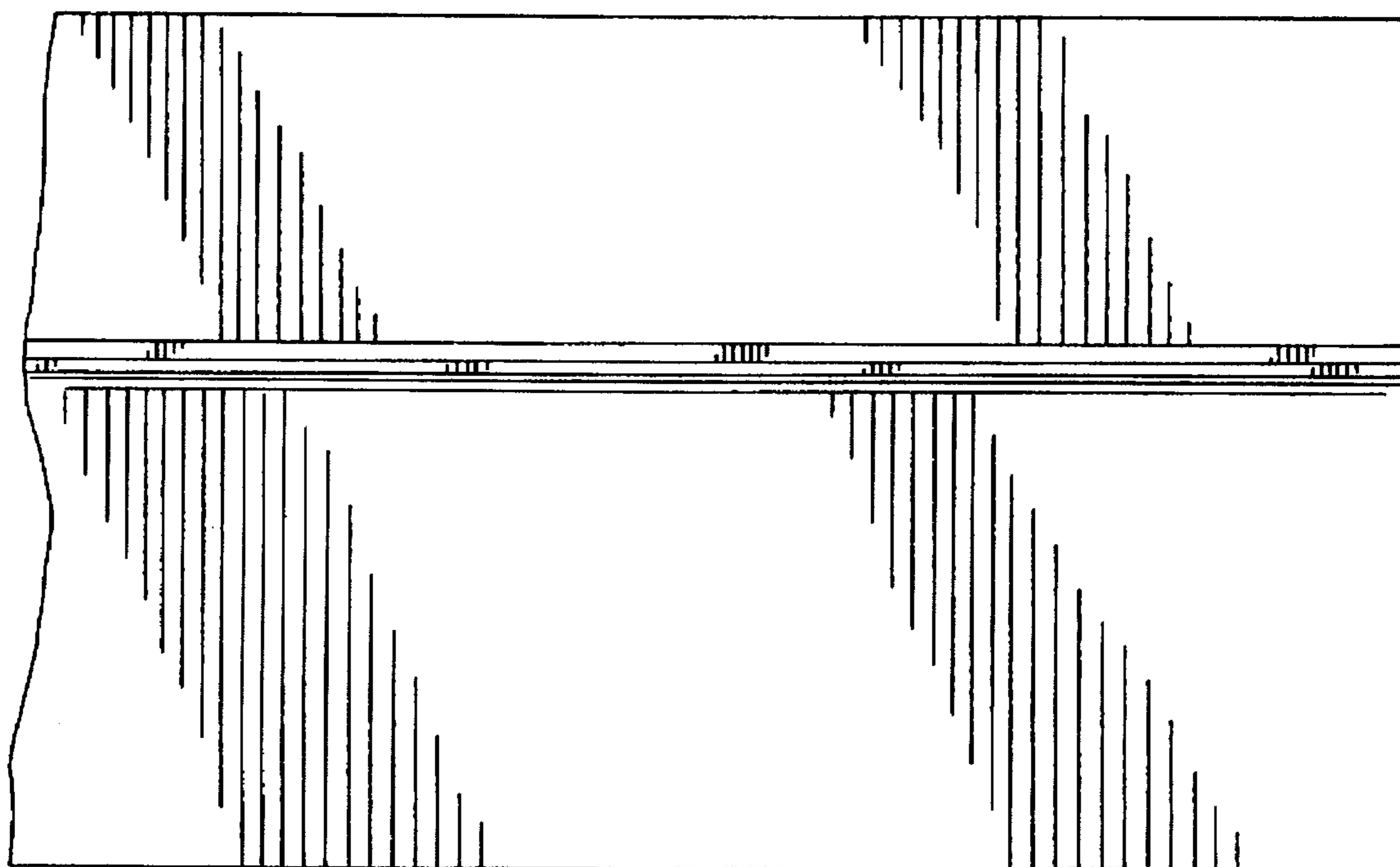

FIG. 6

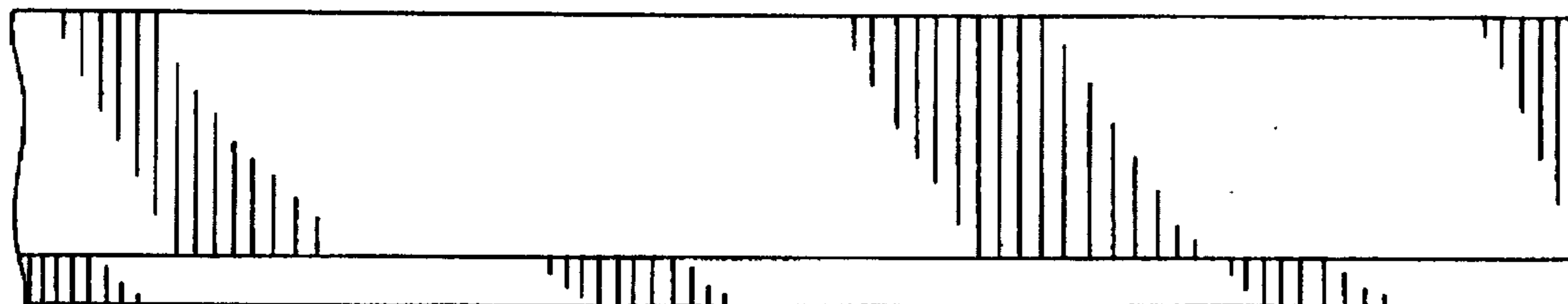

FIG. 7

UNITED STATES PATENT AND TRADEMARK OFFICE
CERTIFICATE OF CORRECTION

PATENT NO. : Des. 384,326

DATED : September 30, 1997

INVENTOR(S) : Charles R. Fetz and James T. Colling

It is certified that error appears in the above-identified patent and that said Letters Patent is hereby corrected as shown below:

On the title page item [56],
Under References Cited please add:

--5,454,597 10/1995 Thomas et al
5,507,405 4/1996 Thomas et al
Great Dane Drawing No. 603005VV
Great Dane Drawing No. 603014VV
Great Dane Drawing No. 13300024
Great Dane Drawing No. 13300027
Great Dane Drawing No. 7122X
Great Dane Drawing No. 7030X
Great Dane Drawing No. 15200615
Great Dane Drawing No. 15200616--

Signed and Sealed this
Second Day of February, 1999

Attest:



Attesting Officer

Acting Commissioner of Patents and Trademarks