



US00D384321S

# United States Patent [19]

[11] Patent Number: Des. 384,321

Anderson

[45] Date of Patent: \*\*Sep. 30, 1997

[54] BOAT HULL

[76] Inventor: Carl J. Anderson, 4317 S. River Rd., East China, Mich. 48054

[\*\*] Term: 14 Years

[21] Appl. No.: 55,995

[22] Filed: Jun. 19, 1996

[51] LOC (6) Cl. .... 12-06

[52] U.S. Cl. .... D12/310; D12/314

[58] Field of Search ..... D12/300-318; 114/283, 61, 291, 288, 290, 56, 62

5,203,728	4/1993	Kobayashi	440/38
5,211,126	5/1993	Johnson	114/61
5,231,945	8/1993	Ackerbloom	114/56
5,317,982	6/1994	Jägers	114/56
5,351,642	10/1994	Ackerbloom	114/291
5,390,624	2/1995	Barnes	114/288
5,405,278	4/1995	Garland	440/69
5,427,048	6/1995	Takeuchi	114/288
5,443,026	8/1995	Wenstadt et al.	114/56
5,452,675	9/1995	Devin	114/291
5,474,014	12/1995	Russell	114/288
5,476,061	12/1995	Ackerbloom	114/290

Primary Examiner—Kay H. Chin  
Attorney, Agent, or Firm—Edgar A. Zarins; Malcolm L. Sutherland

## [56] References Cited

### U.S. PATENT DOCUMENTS

Re. 31,563	4/1984	Stout et al.	114/283
D. 189,656	1/1961	Eddy	D12/314
D. 220,661	5/1971	Line	D12/313
1,318,413	10/1919	Ruhe	
1,396,831	11/1921	Gardner	
2,134,042	10/1938	Hoffman	
3,177,836	4/1965	Salamin	
3,469,549	9/1969	Rae	
3,661,109	5/1972	Weiland	
3,763,810	10/1973	Payne	
3,967,571	7/1976	Mut	114/283
4,192,248	3/1980	Moyer	114/56
4,231,314	11/1980	Peters	114/291
4,300,889	11/1981	Wormser	440/69
4,371,350	2/1983	Kruppa et al.	440/69
4,383,828	5/1983	Wynne	440/69
4,509,927	4/1985	Ikeda	440/89
4,609,360	9/1986	Whitehead	440/69
4,652,245	3/1987	May	440/69
4,915,668	4/1990	Hardy	440/69
4,924,797	5/1990	Solia	114/288
4,940,436	7/1990	Newman	440/112
4,977,845	12/1990	Rundquist	114/289
5,111,767	5/1992	Haines	114/288

## [57] CLAIM

The ornamental design for a boat hull, as shown and described.

### DESCRIPTION

FIG. 1 is a perspective view of a boat hull showing my new design;  
 FIG. 2 is a side view thereof, the opposite side being a mirror image of the side shown;  
 FIG. 3 is a top view thereof;  
 FIG. 4 is a bottom view thereof;  
 FIG. 5 is a front view thereof;  
 FIG. 6 is a rear view thereof;  
 FIG. 7 is a cross-sectional view taken along lines 7—7 of FIG. 2;  
 FIG. 8 is a cross-sectional view taken along lines 8—8 of FIG. 2; and,  
 FIG. 9 is a cross-sectional view taken along lines 9—9 of FIG. 2.  
 The broken lines shown in FIGS. 1 through 6 are for illustrative purposes only and form no part of the claimed design.

1 Claim, 3 Drawing Sheets

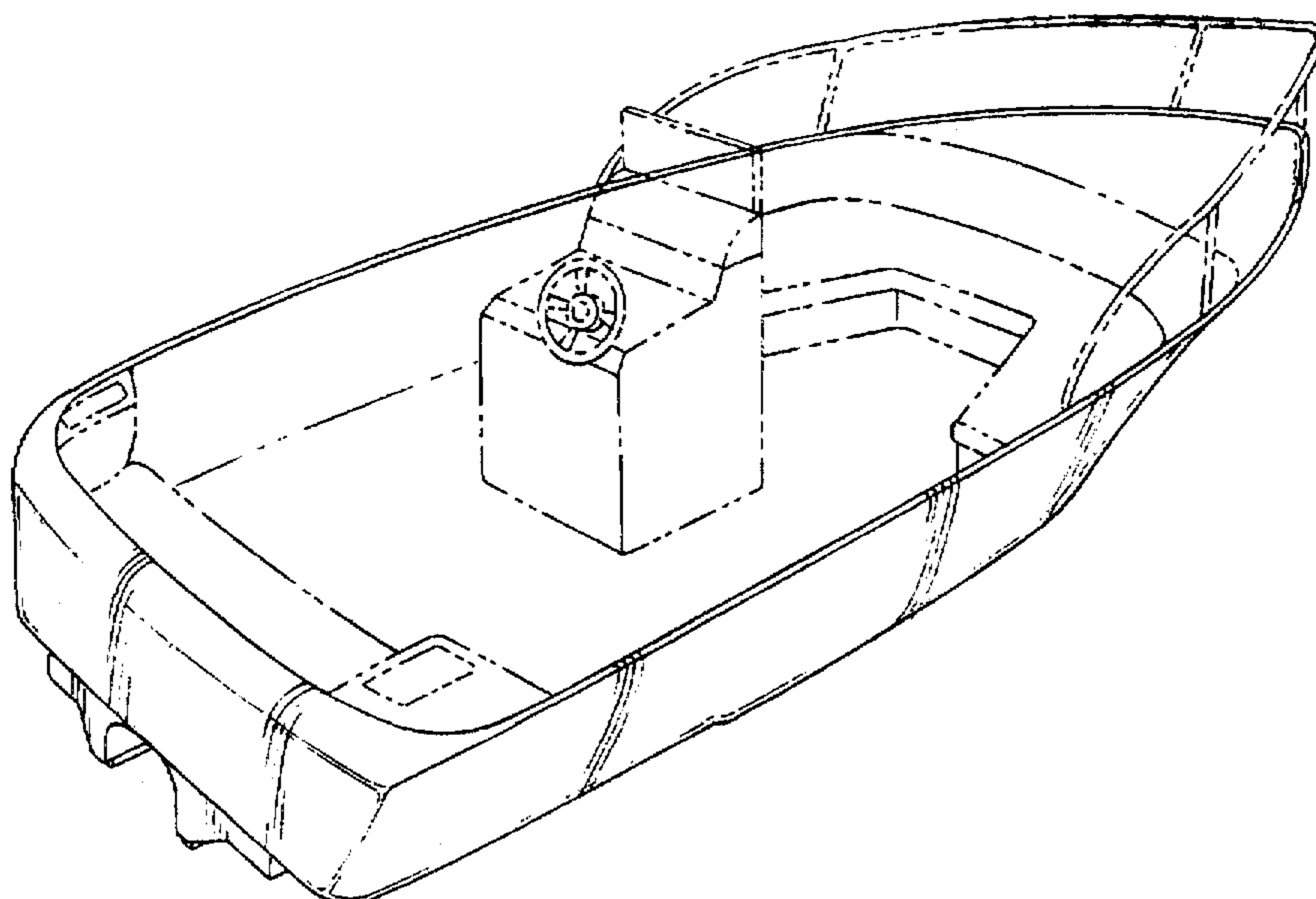

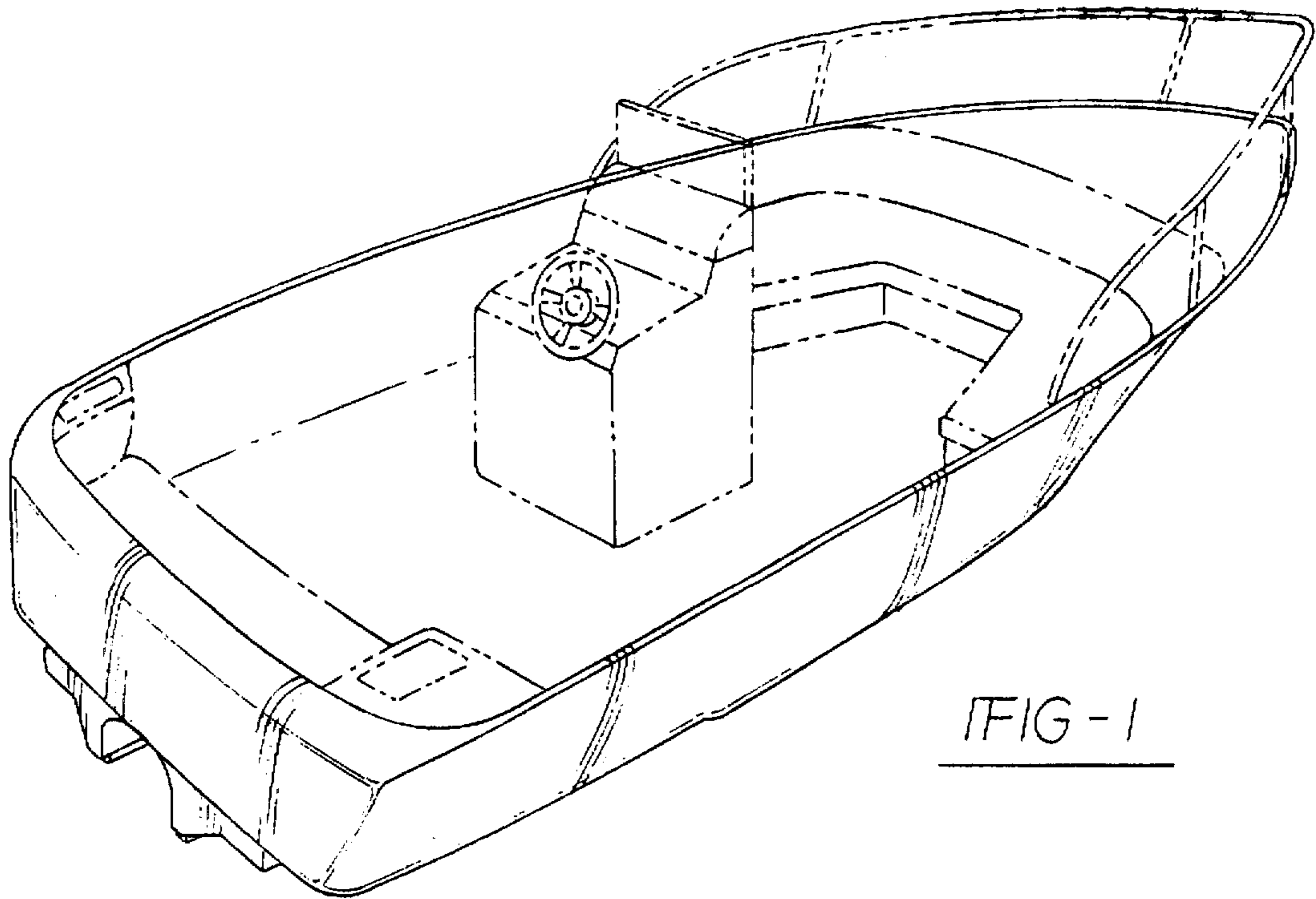

FIG-1

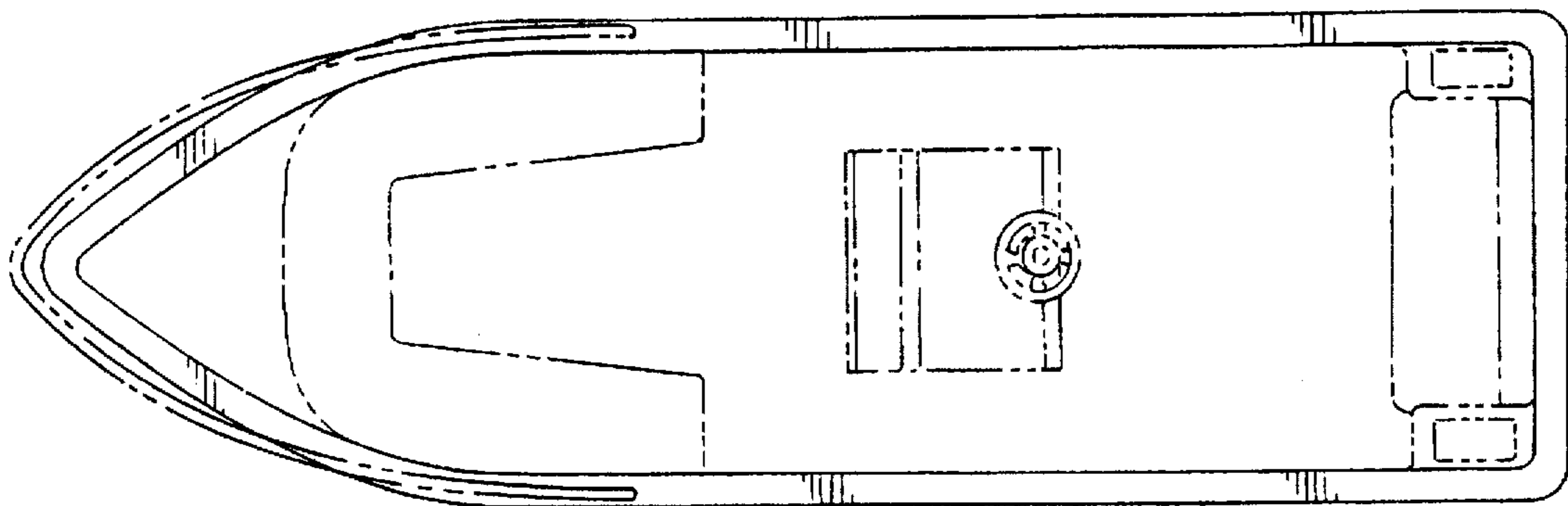
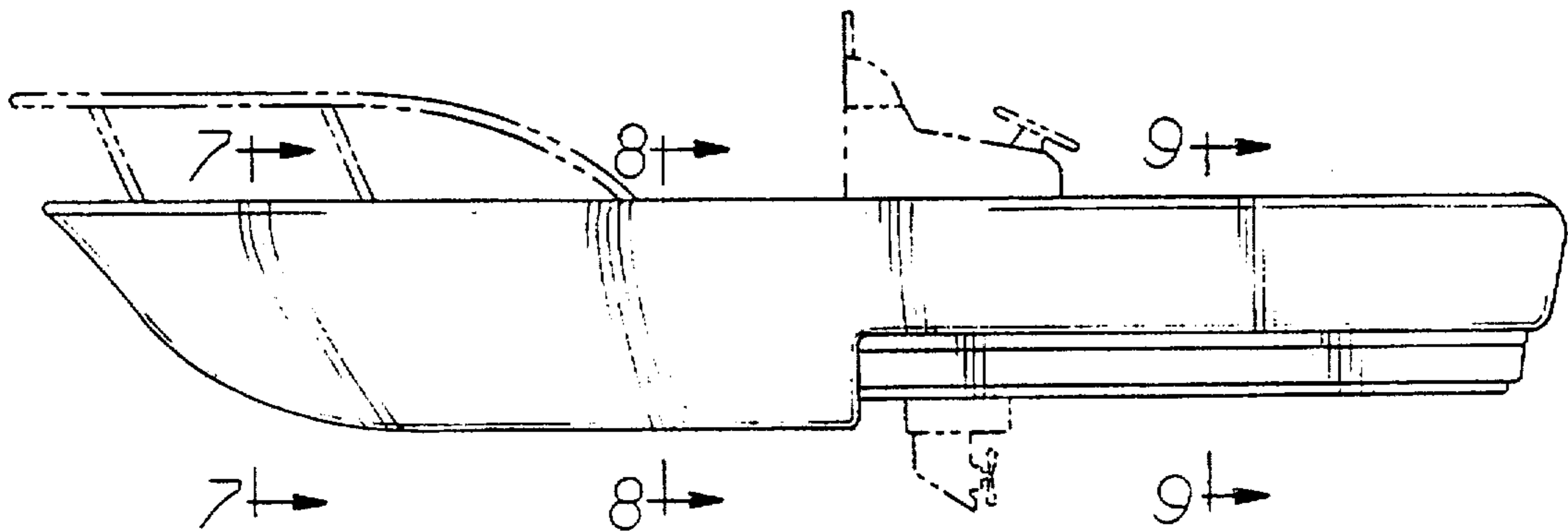

FIG-3

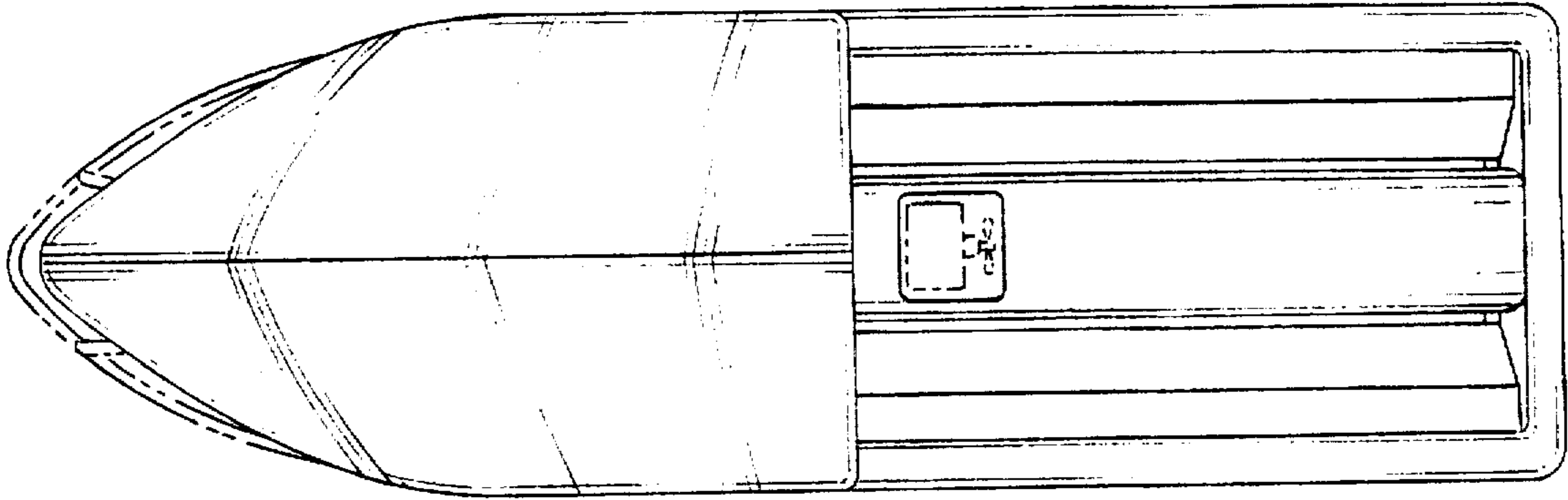

FIG - 4

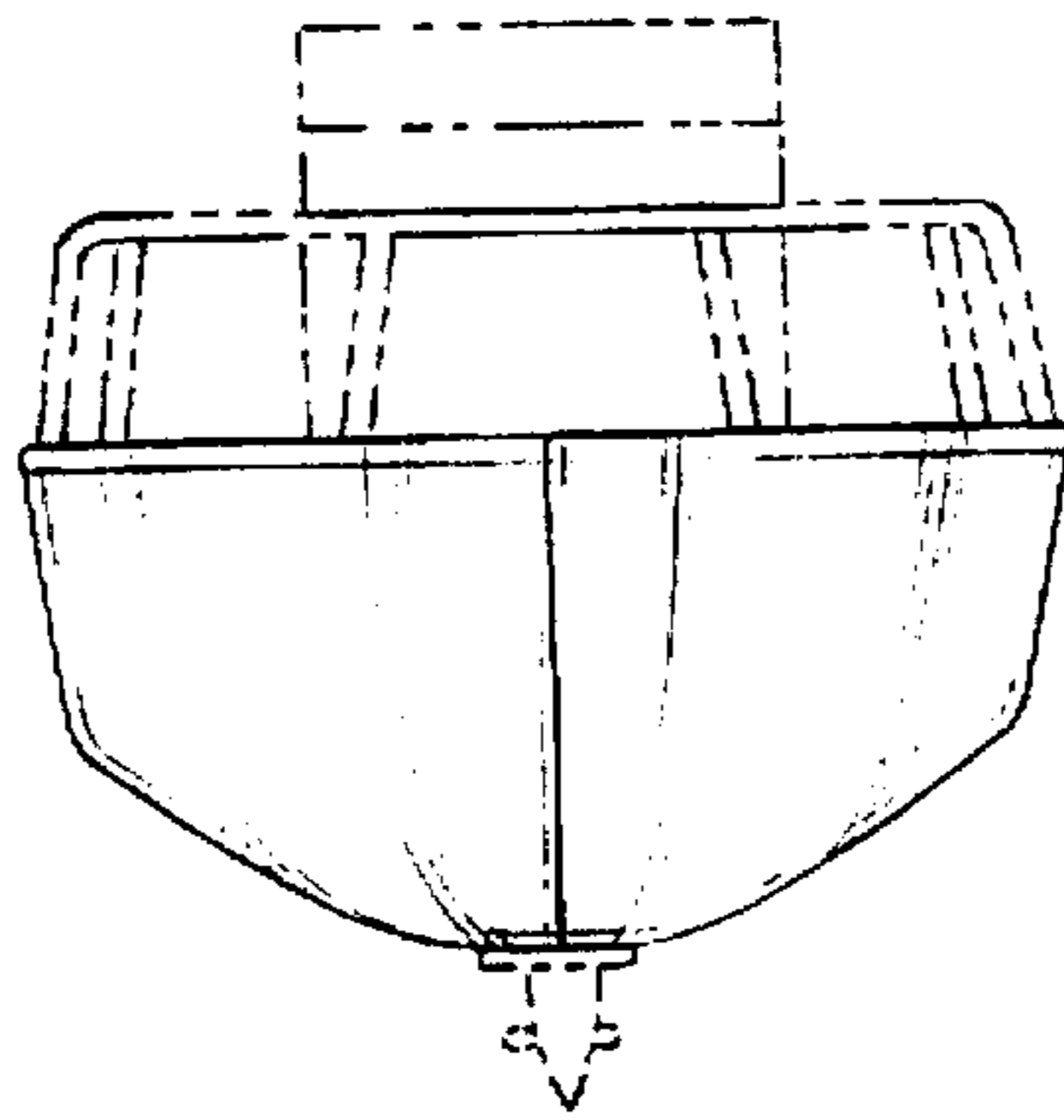

FIG - 5

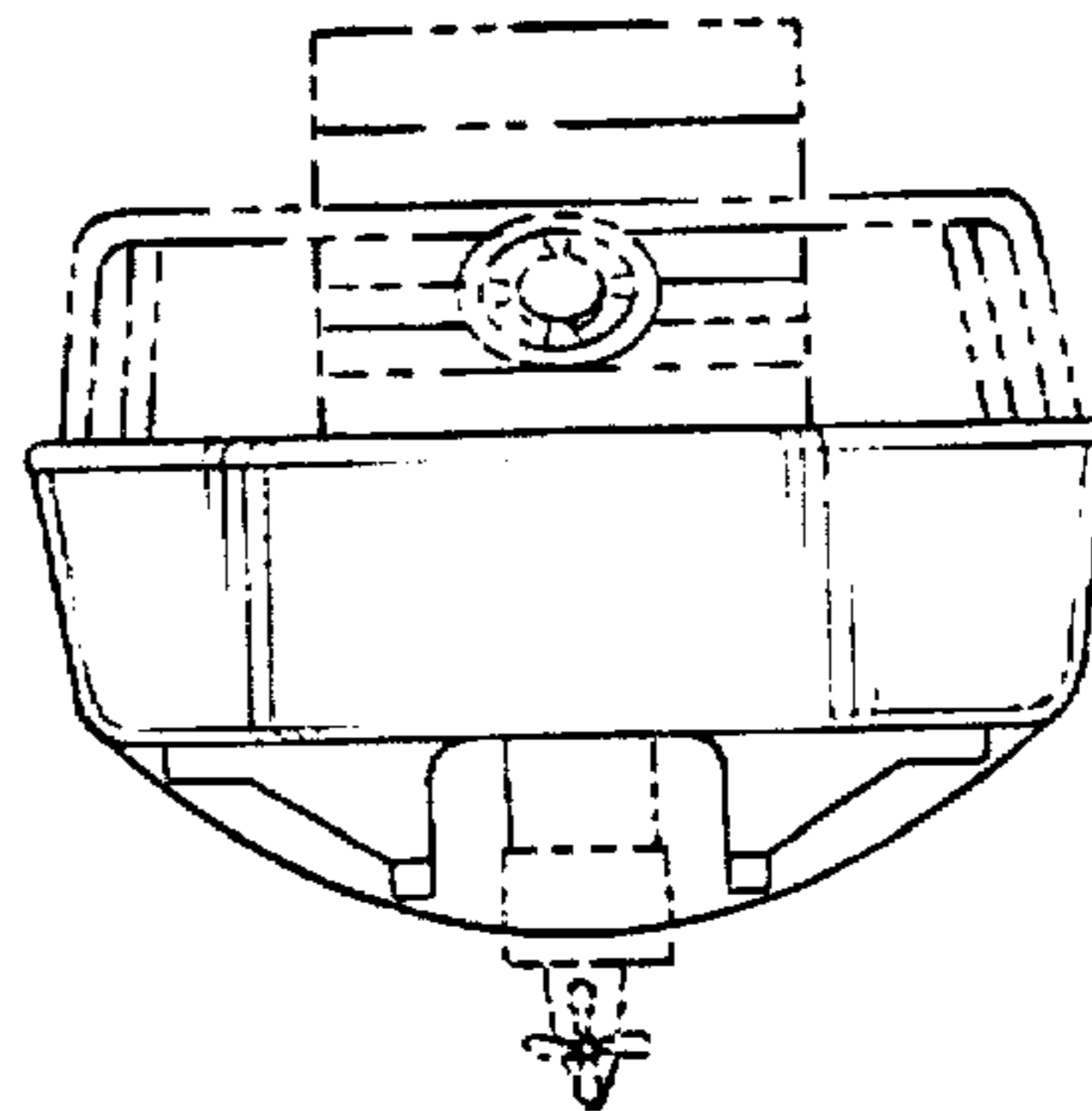

FIG - 6

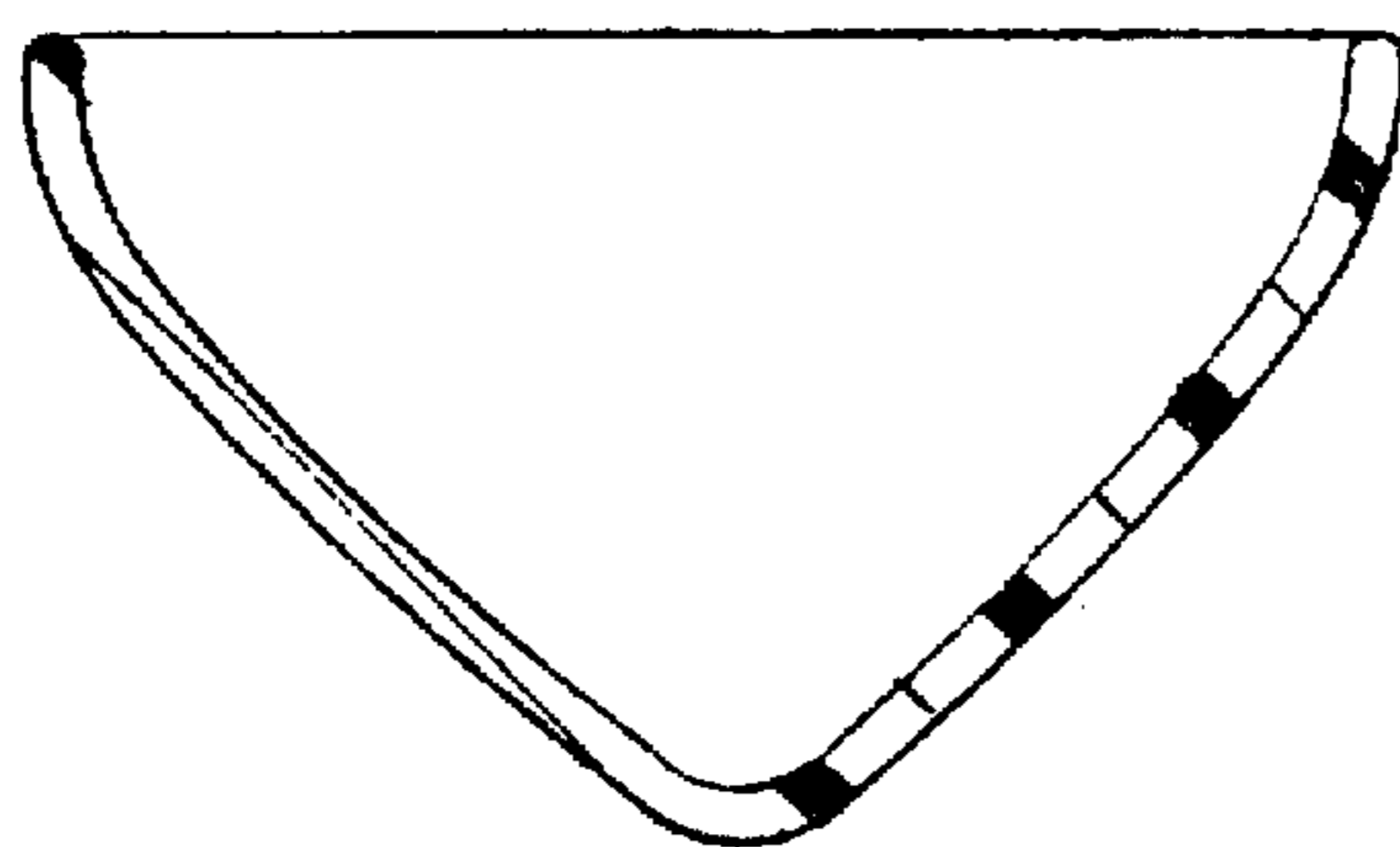

FIG - 7

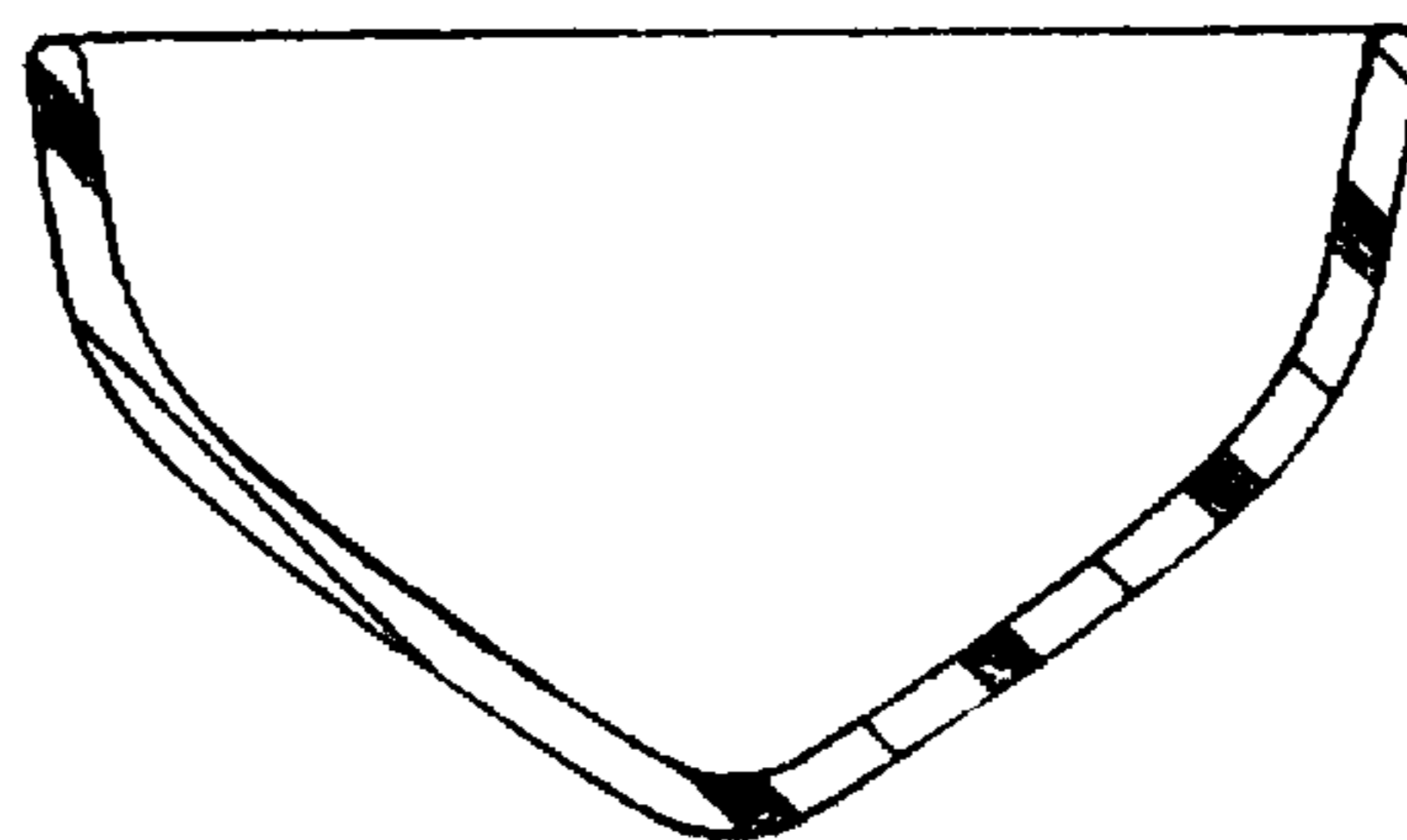

FIG - 8

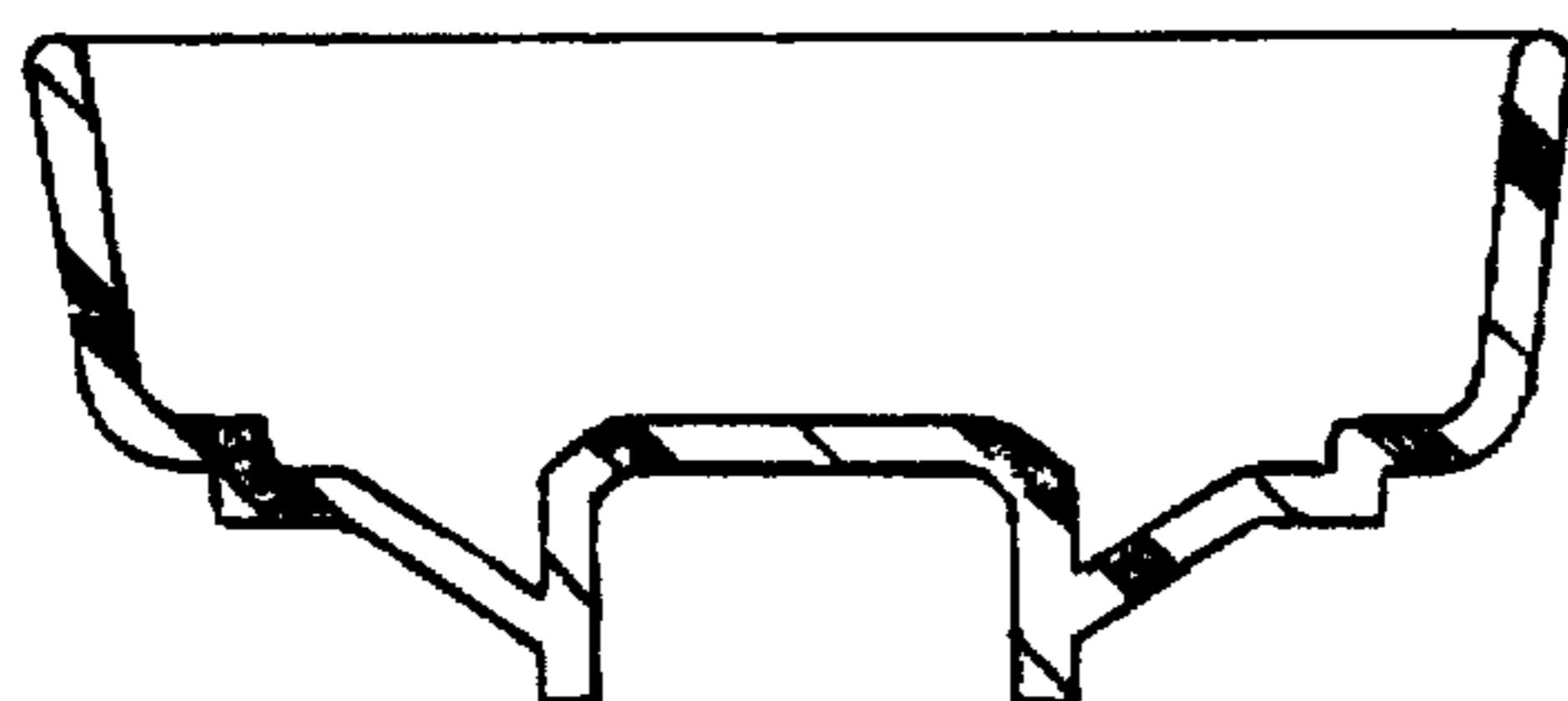

FIG - 9